

Sumitomo Drive Technologies

Sumitomo Machinery Corporation of America
Headquarters & Manufacturing
 4200 Holland Boulevard, Chesapeake, VA 23323



Sumitomo Machinery Corp. of America
 Chesapeake, VA
 Glendale Heights, IL
 Verona, VA

Phone: +1.757.485.3355
 +1.630.752.0200
 +1.540.213.2442
 Fax: +1.757.485.7490
 +1.630.752.0208
 +1.540.213.2222

SM Cyclo de Mexico, S.A. de C.V.
 Monterrey
 Guadalajara
 Ciudad de México

+52.81.8144.5130
 +52.33.3675.4323
 +52.55.2282.8700
 +52.81.8144.5130 ext. 3109
 +52.33.3675.4418
 +52.55.2282.8700

SM Cyclo of Canada, Ltd.
 Toronto, ON
 Vancouver, BC

+1.905.469.1050
 +1.604.525.5403
 +1.905.469.1055
 +1.604.525.0879

SM Cyclo Colombia, S.A.S.
 Bogotá

+57.1.300.0673
 +57.1.300.0673 ext. 105

Sumitomo Indústrias Pesadas do Brasil Ltda.
 São Paulo

+55.11.4403.9292
 +55.11.4403.9292

SM Cyclo de Chile Ltda.
 Santiago
 Antofagasta
 Concepción

+56.2.2892.7000
 +56.5.5256.1611
 +56.41.246.9806
 +56.2.2892.7001
 +56.5.5256.1616
 +56.41.246.9171

SM Cyclo de Guatemala Ensambladora, Ltda.
 Guatemala

+502.6648.0500
 +502.6648.9171

SM Cyclo de Argentina, SA
 Buenos Aires

+54.3327.45.4095
 +54.3327.45.4099

World Headquarters

Japan
 Sumitomo Heavy Industries, Ltd.
 Power Transmission & Controls Group
 ThinkPark Tower, 1-1, Osaki 2-chome,
 Shinagawa-ku, Tokyo 141-6025 Japan
 Tel: +81-367-37-2511 • Fax: +81-368-66-5160

www.sumitomodrive.com
E-mail: Customer_Service@suminet.com

Sumitomo Drive Technologies

CYCLO® 6000

Gearmotors

Sumitomo Drive Technologies



CYCLO® 6000
 Gearmotors



EPNA Motors (1 HP+)

Enhanced Performance (EP,NA) integral motors represent exceptional value to customers. To maximize the performance of the motors, a host of advanced features has been developed providing tangible benefits to the users.

All in one

To simplify transactions throughout the continent, North American version (.NA) features standard multiple listings including DOE, UL and CSA, along with CE marking. Other versions are available for premium performance with European 50 Hz voltages.

Exceptionally long life

Our Premium Efficient Motors feature lower temperature rise and robust class "F" insulation. The combination of those attributes yield reduced motor operating temperatures that exponentially increase the thermal life of the insulation.

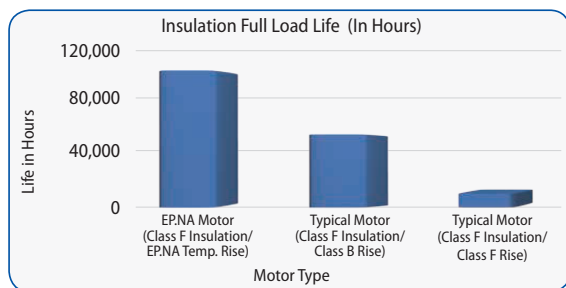

Eco friendly

Premium efficiency, mandated by the DOE, shrinks the carbon footprint by delivering more torque at the same level of energy consumption. Higher starting torques may allow smaller motors to be selected for some applications.

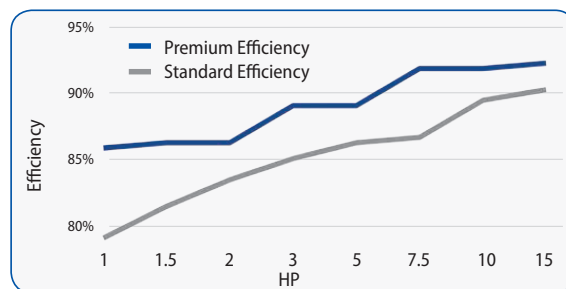

Get Pricing and CAD models for Sumitomo Drive Technologies products today at www.sumitomodrive.com/Configurator

Cost-effective

The premium efficiency design is cost-effective in reducing energy consumption throughout the full speed range, resulting in a lower total lifecycle cost.

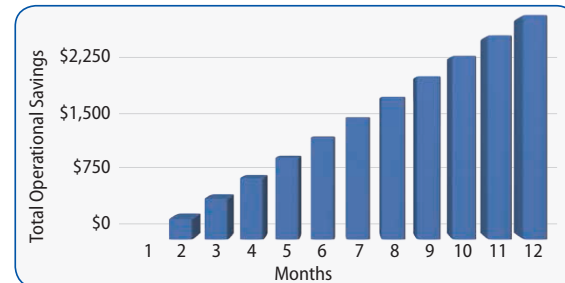

The assumptions for the study are as follows:
 9.8 cents of a dollar per kWh • 8600 operating hours annually • A 7.5 kilowatt motor (10 HP) • IE3 motor costing 25% more than the IE1 motor • IE3 premium efficiency motor being 2.8% more efficient than the IE1 standard efficiency motor

Inverter duty

All of the motors feature corona resistant magnet wire that resists the voltage spikes that are inherent to the widely applied IGBT inverters and extends insulation life. Inverter duty brake motors are also available. The non-brake motors are suitable for a 10:1 turndown. The advanced fan design helps to keep the motor running cool at lower input speeds.

Optimized Geometry

Increasing motor size is one of several techniques to reduce losses and achieve premium efficiency. Sumitomo optimized its existing external envelope while still accommodating a large motor core. The result is a compact premium efficient motor.

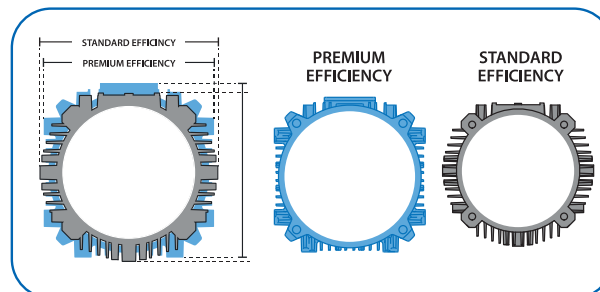

E-mail: SMA.CustomerService@shi-g.com



Product Configurator: www.sumitomodrive.com/Configurator

Sumitomo Drive Technologies' online product Configurator streamlines the selection process, enabling you to build **our power transmission products for your specific application.**

Configure your Sumitomo Drive Technologies products today at www.sumitomodrive.com/Configurator

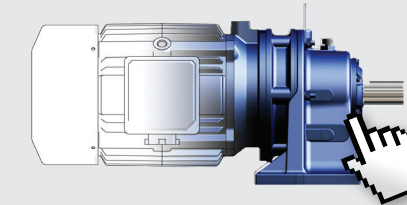

Scan with a QR code reader to login!

► Cyclo® 6000 offers an expanded range of standard sizes and ratings. Use this chart to select a Cyclo® 6000 when replacing Cyclo® series 3000 and 4000 models.

CYCLO Frame Size Cross Reference

SERIES		
3000	4000	6000
		6060
3075	4075	6065
		6070
3085	4085	6075
		6080
		6085
3090	4090	6090
3095	4095	6095
3097	4097	6095
3100	4100	6100
3105	4105	6105
310H	410H	610H
		6110
		6115
3110	4110	6120
3115	4115	6125
311H	4125	612H
3140	4130	6130
3145	4135	6135
		6140
3155	4145	6145
315H	4155	614H
3160	4160	6160
3165	4165	6165
316H	416H	616H
3170	4170	6170
3175	4175	6175
3180	4180	6180
3185	4185	6185
3190	4190	6190
3195	4195	6195
3205	4205	6205
3215	4215	6215
3225	4225	6225
3235	4235	6235
3245	4245	6245
3255	4255	6255
3265	4265	6265
3275	4275	6275

Table of Contents

1. General Information

2. Gearmotors

- How to Select.....2.2
- AGMA Load Classifications.....2.4
- Configure a Model Number (Nomenclature).....2.6
- Selection Tables
 - 1/8 HP - 75 HP.....2.10
- Dimensions:
 - Greased - Universal Foot Mount (CNHM).....2.102
 - Oil Lubricated - Horizontal Foot Mount (CHHM).....2.110
 - Greased - Universal V-Flange Mount (CNVM).....2.132
 - Oil Lubricated - Vertical V-Flange Mount (CVVM).....2.140
 - Greased - Universal F-Flange Mount (CNFM).....2.162
 - Oil Lubricated - Horizontal F-Flange Mount (CHFM).....2.170

3. Options

- Vertical F-Flange Mount, Overhead Drive (XXDVB).....3.2
- Slide Rail.....3.4
- Low Speed Shaft Specifications.....3.5
- Food and Industry Packages.....3.6

4. Technical Information

- Overhung Loads - Slow Speed Shaft.....4.2
- R1 High Capacity Bearings.....4.4
- R2 Ductile Iron Housing+High Cap. Bearings4.5
- Axial Load Calculations.....4.6
- Overhung Loads - High Speed Shaft.....4.7
- Lubrication.....4.10
- Motor Conduit Information.....4.16
- Fractional Motor Performance Data, 60Hz.....4.21
- Motor Performance Data (EP) 1HP+, 60Hz.....4.23
- CE Motor Performance Data, 50Hz.....4.26
- Notes on Inverter Operation.....4.28
- Motor Wiring Diagrams.....4.29
- Motor Thermal Ratings.....4.31
- Brakemotor Characteristics.....4.32
- Brakemotor Wiring Diagrams.....4.37
- Brake Rectifiers and Power Modules.....4.42
- Warranty.....4.43

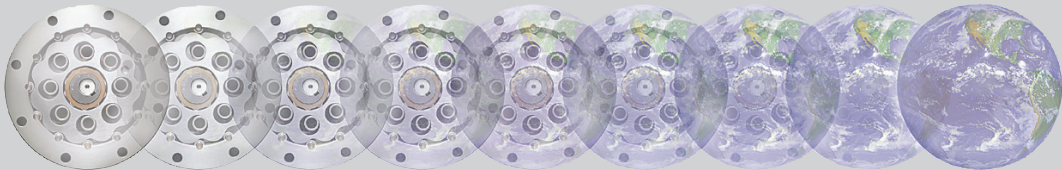

Consistent, Reliable Performance
All rotating components are fully hardened, vacuum degassed bearing grade steel

► **Wide variety of inputs available, including C-Face, Free-Shaft, Gearmotor and Brakemotor**

Custom output shaft diameters and stainless steel available as options, contact Sumitomo Customer Service for more information.

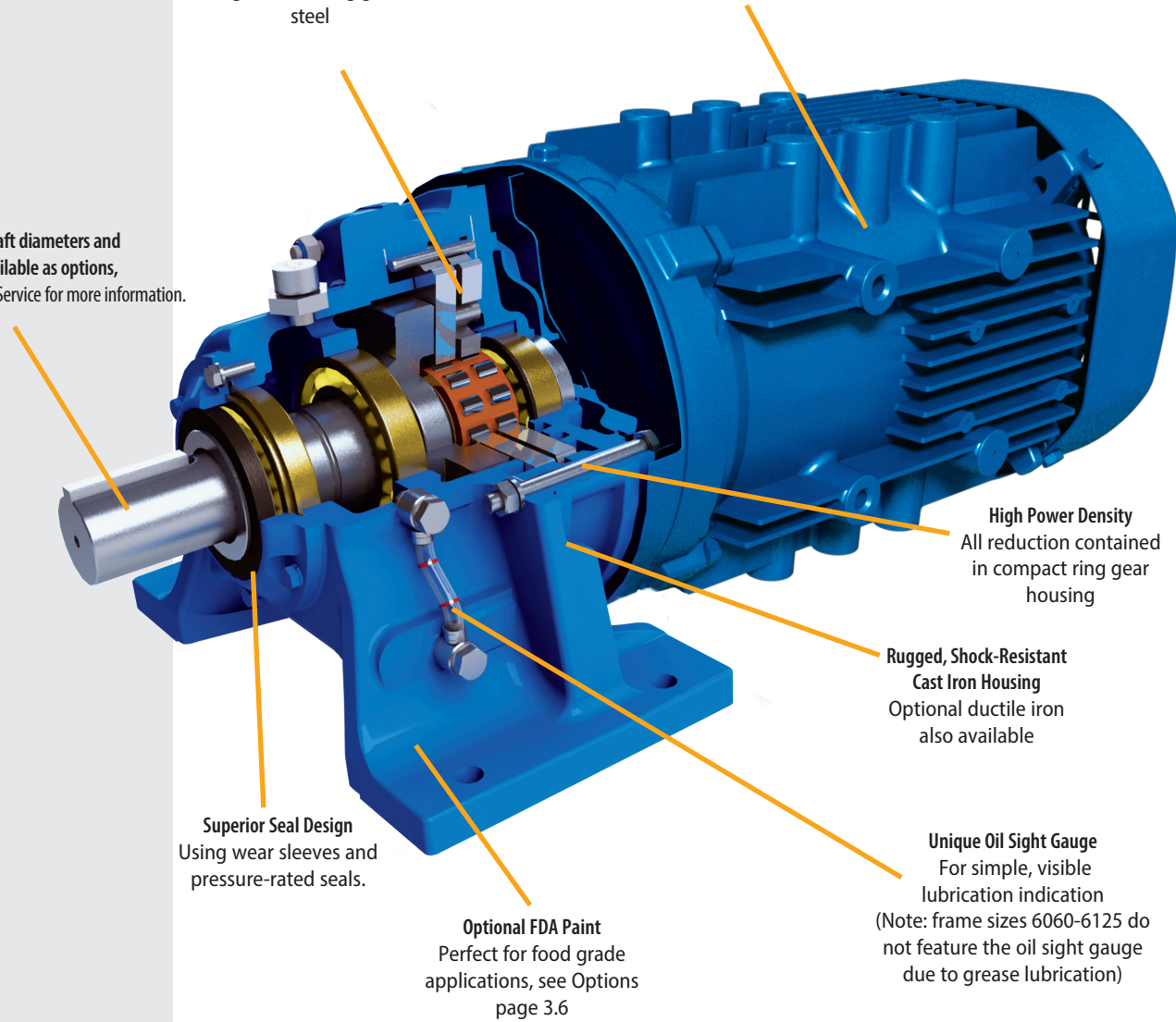

Product Description

Sumitomo Cyclo® speed reducers and gearmotors are the premier in-line drives. The revolutionary Cyclo® design provides quiet, efficient and reliable performance exceeding that of involute tooth gear designs. Unlike geared designs, the Cyclo's reduction components operate in compression rather than shear, which results in exceptionally rugged and shock resistant performance. The Cyclo® technology coupled with innovative product options and accessories offer the most extensive range of application solutions available.

Features & Benefits

- **Cycloidal speed reduction technology**
~ Quiet, efficient and reliable operation with high torque density and compact size
- **Maintenance free for greased units 6060-6125**
- **Modular design**
~ Interchangeable cast iron housings in foot, flanged or face mount configurations
- **Universal mounting arrangements**
~ Available free-shaft, quill hollow shaft, C-face, shovel base, and top-mount inputs
- **Internal components manufactured from hardened, vacuum-degassed, bearing grade steel**
~ Minimal vibration, low noise, low backlash and extended operational life
- **The best product warranty**
~ The 24 month warranty backs up the superb Cyclo® product reputation

General Specifications Summary

Sizes:	23 sizes (5lbs to 5,000lbs)
Torque Rating:	55 to 603,000 lb in
HP Rating:	0.125 to 75 HP for integral gearmotor 0.10 to 235 HP for reducer only
Ratio Range:	3:1 to 119:1 (single) 121:1 to 7,569:1 (double) 8,041:1 to 658,503:1 (triple)
Mounting:	Foot, Flange, Face Mount
Motor Standards:	NEMA, IEC, JIS, UL, CSA, CE

► **Sumitomo's Cyclo 6000 is extremely torque dense and is an inline gearmotor**

- Connection free design
- Rugged forged output shaft
- Direct acting brake option
- Unmatched durability
- Foot and Flange Styles

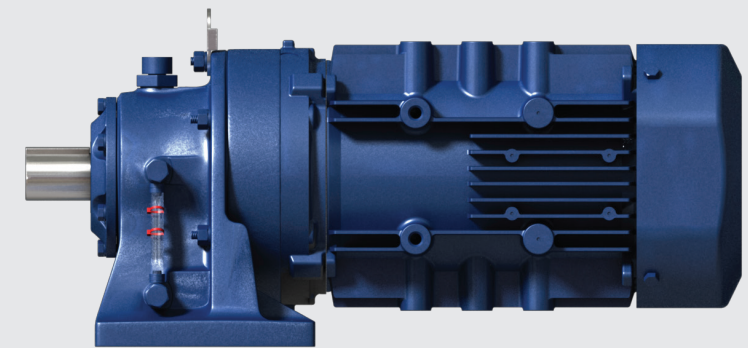

For additional CYCLO® 6000 information, please visit www.sumitomodrive.com

Unmatched Reliability, Exceptional Performance

► Cyclo® speed gearmotors are designed to withstand shockloads exceeding 500% of their ratings

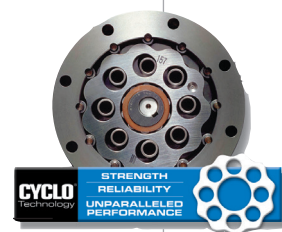

► Applications

- Conveyors
- Food Machinery
- Mixers
- Automotive Plants
- Recycling Machines
- Poultry Plants
- Sawmills and Wood Mills
- Wastewater Treatment
- Steel Mills
- Construction Equipment
- Paper Mills
- Processing Plants

Product Range (Standard Motor and Reducer Combinations)

Reduction Ratios 3 - 119

Combinations with 1450 and 1750 RPM motor

Input Type	Planetary	Cyclo																			
		Ratio	3	5	6	8	11	13	15	17	21	25	29	35	43	51	59	71	87	119	
Actual Output RPM	1450	50 Hz	483	290	242	181	132	112	96.7	85.3	69.0	58.0	50.0	41.4	33.7	28.4	24.6	20.4	16.7	12.2	
	1750	60 Hz	583	350	292	219	159	135	117	103	83.3	70.0	60.3	50.0	40.7	34.3	29.7	24.6	20.1	14.7	
Motor Power HP (kW)	1/8 (0.1)																				
	1/4 (0.2)																				
	1/3 (0.25)																				
	1/2 (0.4)																				
	3/4 (0.55)																				
	1 (0.75)																				
	1.5 (1.1)																				
	2 (1.5)																				
	3 (2.2)																				
	5 (3.7)																				
	7.5 (5.5)																				
	10 (7.5)																				
	15 (11)																				
	20 (15)																				
	25 (18.5)																				
30 (22)																					
40 (30)																					
50 (37)																					
60 (45)																					
75 (55)																					

- Standard efficiency motor
- Premium efficiency or IE3 motor

Reduction Ratios 104 - 7569

Combinations with 1450 and 1750 RPM motor

Input Type	Planetary	Cyclo																											
		Ratio	104	121	143	165	195	231	273	319	377	473	559	649	731	841	1003	1247	1479	1849	2065	2537	3045	3481	4437	5133	6177	7569	
Actual Output RPM	1450	50 Hz	13.9	12.0	10.1	8.79	7.44	6.28	5.31	4.55	3.85	3.07	2.59	2.23	1.98	1.72	1.45	1.16	0.98	0.754	0.702	0.572	0.476	0.417	0.327	0.282	0.235	0.192	
	1750	60 Hz	16.8	14.5	12.2	10.6	8.97	7.58	6.41	5.49	4.64	3.70	3.13	2.70	2.39	2.08	1.74	1.40	1.18	0.946	0.847	0.690	0.575	0.503	0.394	0.341	0.283	0.231	
Motor Power HP (kW)	1/8 (0.1)																												
	1/4 (0.2)																												
	1/3 (0.25)																												
	1/2 (0.4)																												
	3/4 (0.55)																												
	1 (0.75)																												
	1.5 (1.1)																												
	2 (1.5)																												
	3 (2.2)																												
	5 (3.7)																												
	7.5 (5.5)																												
	10.5 (7.5)																												
	15 (11)																												
	20 (15)																												
	25 (18.5)																												
30 (22)																													
40 (30)																													
50 (37)																													
60 (45)																													
75 (55)																													

- Standard efficiency motor
- Premium efficiency or IE3 motor

FAQs

Common Configurations

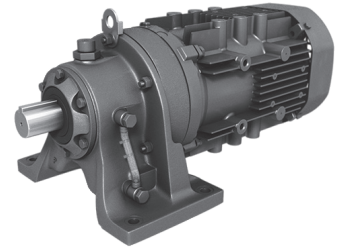

Single Reduction, Horizontal Foot Mount Brakemotor



Single Reduction, Flange Mount

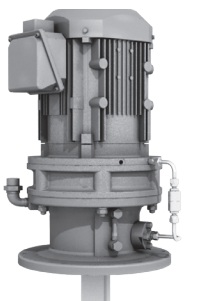

Single Reduction, V-Flange Mount



Double Reduction

How do I select a Cyclo® gearmotor?

Selection is based on the motor horsepower and/or torque requirements at the output shaft. The Cyclo® gearmotor has particularly high efficiencies over a wide range of reduction ratios, which frequently permits the use of reduced input power requirements (smaller HP motor) without sacrificing output shaft torque. The selection procedures in this catalog will guide you in choosing the most efficient gearmotor for your application.

What information do I need to get started in the selection process?

To select the proper gearmotor for your application, you will need to know:

- Application: type of driven machine
- Hours of operation per day
- Motor horsepower (HP) and speed (RPM)
- Mounting position

If there are any special environmental factors or operation requirements, they must also be noted. This information will be important in determining the Service Factor of your application.

What are Service Classes and how are they used?

In general, gearmotors are rated for the specific conditions and operating requirements of the application by the use of AGMA-defined Service Classes. There are three AGMA Service Classifications for gearmotors: uniform (I), moderate shock (II) and heavy shock (III) (pages 2.4-2.5) The Service Classes are used in the product selection process to adjust for the specific conditions and operating requirements of your application.

What do I do if my application has particularly severe operating conditions?

The standard ratings for Cyclo® are based on 10-hour daily service under conditions of uniform loads (equivalent to AGMA service Class I). By following the product selection process, you will determine and apply the Service Factors to compensate for longer periods of operation and/or severe operating conditions.

How can I be sure that the gearmotor can withstand periodic excessive overloads?

Cyclo® Gearmotors provide 500% momentary intermittent shock load capacity. Planetary gearmotors can accommodate 300% momentary shock loads. For applications with shock loads greater than 500%, consult an SMA Application Engineer.

What are the standard input speeds?

In general terms, the speeds are 1750 and 1165 RPM at 60Hz, and 1450 and 980 RPM at 50Hz. When non-standard input speeds are used, the horsepower and torque ratings also vary.

What thermal capacity limitations does the Cyclo® have?

The Cyclo® gearmotor, by virtue of its smooth, almost frictionless operation (unlike traditional helical gears), has a thermal rating that far exceeds its mechanical capacity and all but eliminates the conventional limitations due to heat under normal ambient conditions.

What inverter turn-down ratio is available?

A 10:1 ratio is standard for motor without brake. Breakmotors are more limited with 4:1 or better depending on power. A 1000:1 ratio is available in a C-face configuration.

Enhanced Performance (EP) Motor FAQs (1HP+)

What efficiency level are these Enhanced Performance (EP) motors?

The EP motor (applies to 1HP and above) is a Premium efficiency class, or International Efficiency 3 (IE3) design. Our integral fractional (less than 1HP) motors are not EP and are classified as standard efficiency IE1 motors.

What standards do these motors meet?

All Sumitomo motors are compliant with the Energy Policy and Conservation Act (EPAAct), as recently amended by the Department of Energy with a new ruling.

EP Sumitomo motors met the efficiency levels promoted by the Consortium for Energy Efficiency (CEE) and exceed the Canadian efficiency levels specified by NRCan.

The IE3 efficiency ratings conform to both the IEC Standard 60034-30:2009 and eco-design directive 2005/32/EC.

Will Sumitomo motors work with inverters?

All current EP motors feature corona resistant magnet wire that extends the life of the insulation and enables the motors to resist the voltage spikes common with IGBT variable frequency drives.

What agency listings apply?

All EP motors in this product line are UL recognized, CSA certified and CE marked.

Can the motor be nameplated to operate at 50 hertz?

The motor can be nameplated and will operate at 50 hertz, but depending on the export destination, it may not meet that country's energy efficiency requirements. For areas requiring IE3 performance at 50 hertz, like Asia and Europe, other 50 hertz specific versions can be provided.

Is the selection procedure the same as previous gearmotors?

Similar, the difference is restricted to applications with a large number of across the line starts and stops. Because the EP motors have more inertia and higher inrush current than previous integral motors, a supplemental service factor is applied to these applications using EP motors. The selection procedure for fractional HP units is unchanged.

Are the brakes the same?

The brakes are the same direct acting, fast response types used previously. For motors 1 HP and above they are a new larger model that has been redesigned to match the new motor profiles. Because the EP motor inertia is significantly higher, it may be necessary to adjust external trigger points or limit switches. Since the brake assembly shapes are different, old and new parts are not interchangeable.

What is the standard insulation system?

The motors continue with the Class F system, which limits the temperature rise to a Class B rise, where it bounds the allowable temperature rise to 80°C. It utilizes an insulation system capable of handling a 105°C rise to significantly extend insulation life.

Are EP motors interchangeable with old AF-motors?

The new EP motors without brake have the same 10:1 constant torque speed range as the AF-motor. Motors are dimensionally and performance-wise different so VFD re-programming will be required. For EP brakemotor with use on VFDs, the applicable speed range may be limited. Please consult the factory for options for EP brakemotors.

Will old motors continue to be available?

EP motors will eventually replace the older IE1 motors (does not apply to fractional HP). 1HP+ Older motors do not meet the federally mandated efficiency requirements that went into effect on June 1, 2016. Non-compliant motors after that date cannot be manufactured or imported into the United States.

Should I be concerned if I am replacing an older motor with the new EP motor?

For most applications, the use of the new EP motor will result in a more efficient, cooler-running and energy-saving motor. However, for applications with certain performance constraints, you may need to review the impact of the following:

- larger dimension and weight
- larger moment of inertia
- higher starting current and torque.

If taking an old IE1 motor off a gearmotor and replacing it with the same HP new EP motor, the EP motor will bolt to the old gearmotor. The motor flange diameters, pilot diameters, bolt patterns and shaft diameters all match. Motor body dimensions and weight will change.

Standard Motor Specifications

	Standard Specifications	Standard Specifications with Built-In Brake	
3 Phase Integral Motor	Capacity Range: Power Supply:	1/8 ~ 75HP (0.1 ~ 55 kW), 4P Motor Power: 230/460V, 60Hz, 3Phase 575V, 60Hz, 3Phase	1 ~ 40HP (0.75 ~ 30 kW), 4P, FB Brake Brake Power: 1 ~ 15HP (0.75 ~ 11kW): 230/460V, 60Hz, 1Ph 575V, 60Hz, 1Ph 20 ~ 40HP (15 ~ 30kW): 200 ~ 240V, 60Hz, 1Ph 380 ~ 480V 60Hz, 1Ph 575V, 60Hz, 1Ph
	Motor Standard: Efficiency: Protection:	NEMA Premium Efficiency (IE3) (1 HP+) IP55	NEMA Premium Efficiency (IE3) (1 HP+) IP55 (1 ~ 15HP) IP54 (20 ~ 60HP)
	Certification: Conduit Box: Inverter Operation:	CE Mark, UL Recognized, CSA Approval Diecast Aluminum, NPT Conduit Thread 10:1 Constant Torque Speed Range Insulation Meets NEMA MG1, Part 31	CE Mark, UL Recognized, CSA Approval Diecast Aluminum, NPT Conduit Thread 4:1 Constant Torque Speed Range or better. Insulation Meets NEMA MG1, Part 31
	Capacity Range: Power Supply:	0.75 ~ 55 kW (1 ~ 75HP), 4P Motor Power: 0.75 ~ 4kW (1 ~ 6HP): 220/380V, 50Hz, 3Phase 230/400V, 50Hz, 3Phase 240/415V, 50Hz, 3Phase 5.5 ~ 55kW (1 ~ 75HP): 380V, 50Hz, 3Phase 400V, 50Hz, 3Phase 415V, 50Hz, 3Phase	0.75 ~ 30 kW (1 ~ 40HP), 4P, FB Brake 37 ~ 45 kW (50 ~ 60HP), 4P, ESB Brake Brake Power: 0.75 ~ 4kW (1 ~ 6HP): 220 ~ 380V, 50Hz, 1Ph 5.5 ~ 30kW (1 ~ 40HP): 380 ~ 415V, 50Hz, 1Ph 37 ~ 45kW (50 ~ 60HP): 200 ~ 220V, 50Hz, 1Ph
	Motor Standard: Efficiency: Protection: Certification:	IEC IE3 IP55 CE Mark, UL Recognized 0.75 ~ 37kW (1 ~ 50HP): Diecast Al, Metric Conduit Thread	IEC IE3 IP44 CE Mark
	Conduit Box: Inverter Operation:	45 ~ 55kW (60 ~ 75HP): Cast Iron, Metric Conduit Thread 5:1 Constant Torque Speed Range or better. Insulation Meets NEMA MG1, Part 31	Diecast Aluminum, Metric Conduit Thread 5:1 Constant Torque Speed Range or better. Insulation Meets NEMA MG1, Part 31
	Enclosure: Motor Type: Frame Material:	Totally Enclosed Fan Cooled Type Induction Motor, Squirrel Cage Rotor 1/8 ~ 20HP (0.1 ~ 15kW), 4P: diecast Al 25HP ~ 75HP (18.5 ~ 55kW), 4P: cast iron	Totally Enclosed Fan Cooled Type Induction Motor, Squirrel Cage Rotor 1 ~ 20HP (0.75 ~ 15kW), 4P: diecast Al 25HP ~ 60HP (18.5 ~ 45kW), 4P: cast iron
	Bearings: Insulation:	Deep Groove, Ball Bearing, CM Clearance Class F	Deep Groove, Ball Bearing, CM Clearance Motor: Class F Brake: Class F
	Time Rating:	Continuous	Continuous
	Cyclo® 6000 Reducer	Reduction: Lubrication: Seals: Material: Paint Color: Bearings: Note:	Involute crowned tooth prole for ratios 3:1 and 5:1, planetary arrangement. Internal planetary gear mechanism with trochoidal curved tooth prole for ratio 6:1 and higher. Grease or oil lubricated models available. Nitrile Material, dual lipped, double output seals available. Rugged cast iron and ductile housings Blue, Munsell color number 6.5PB 3.6/8.2 Deep groove ball bearings, cylindrical roller or spherical roller bearings. Listed ratings may be altered if models normally designed for oil lubrication are grease lubricated.
Ambient Conditions	Installation Location: Ambient Temperature: Ambient Humidity: Elevation: Atmosphere:	Indoor (Minimal dust and humidity) 14° ~ 104° F (-10° ~ 40° C) Under 85% Under 3300 feet (1000 meters) Well ventilated location, free of corrosive gases, explosive gases, vapors, and dust	

Housing Styles & Mounting Positions

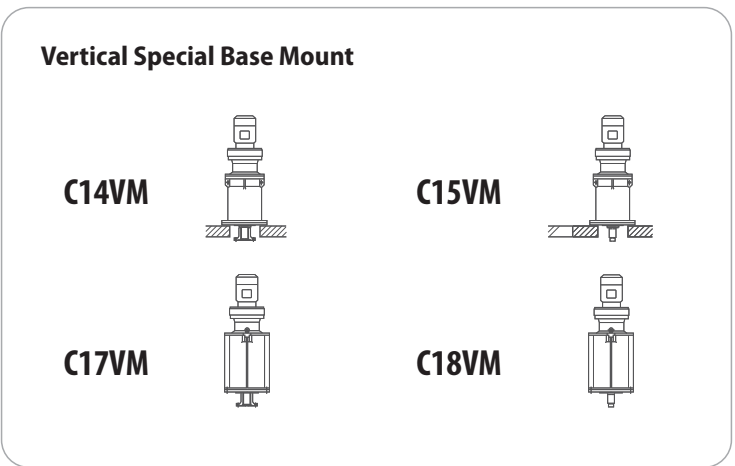
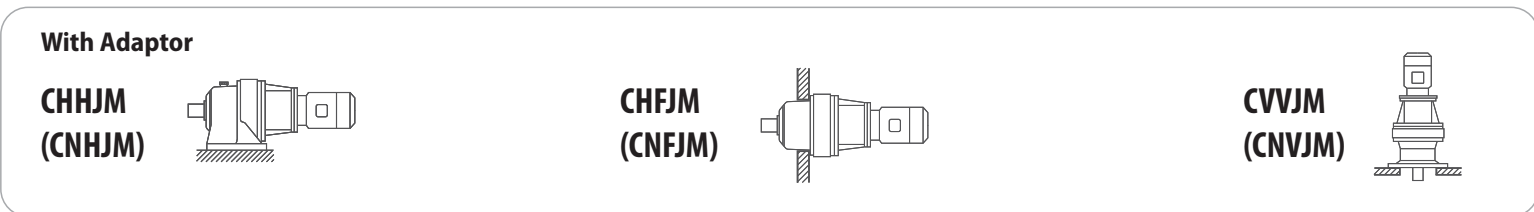
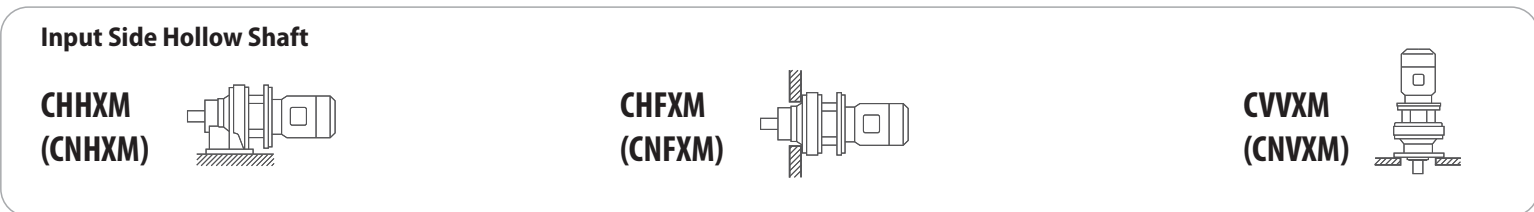
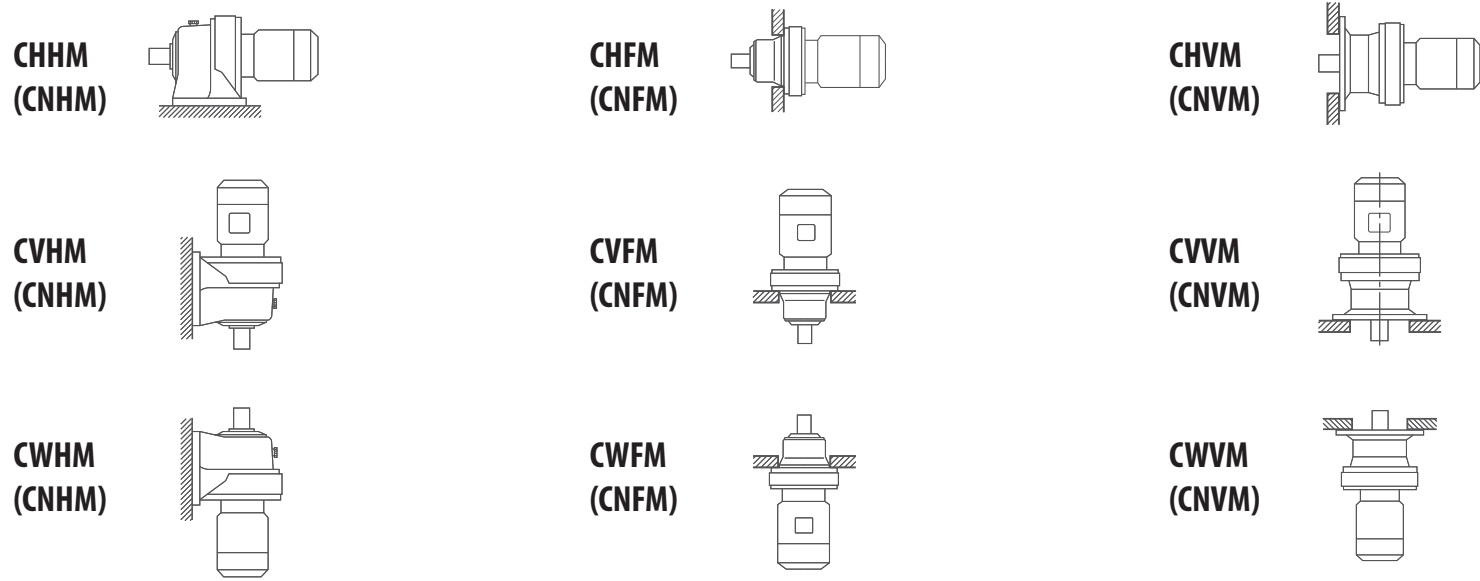

Optional Ratios

Standard Reduction Ratios

Single Reduction								
3*	5*	6	8	11	13	15	17	21
25	29	35	43	51	59	71	87	119
Double Reduction								
104 (13x8)	121 (11x11)	143 (13x11)	165 (15x11)	195 (15x13)	231 (21x11)	273 (21x13)	319 (29x11)	377 (29x13)
473 (43x11)	559 (43x13)	649 (59x11)	731 (43x17)	841 (29x29)	1003 (59x17)	1247 (43x29)	1479 (87x17)	1849 (43x43)
2065 (59x35)	2537 (59x43)	3045 (87x35)	3481 (59x59)	4437 (87x51)	5133 (87x59)	6177 (87x71)	7569 (87x87)	

* Note: Ratios 3 and 5 are planetary.

Optional Reduction Ratios

The following reduction ratios may also be available for certain specifications; please consult factory. The output shaft RPM listed in the table below represents coupling the reducer with a four-pole motor, 60 Hz, input speed 1750 RPM.

Reduction Ratio	88 (11x8)	90 (15x6)	102 (17x6)	120 (15x8)	126 (21x6)	136 (17x8)	150 (25x6)	168 (21x8)	169 (13x13)	174 (29x6)	187 (17x11)	200 (25x8)	210 (35x6)	221 (17x13)	225 (15x15)
Output Speed RPM	19.9	19.4	17.2	14.6	13.9	13.9	11.7	10.4	10.4	10.1	9.36	8.75	8.33	7.92	7.78
Reduction Ratio	232 (29x8)	255 (17x15)	258 (43x6)	275 (25x11)	280 (35x8)	289 (17x17)	306 (51x6)	315 (21x15)	325 (25x13)	344 (43x8)	354 (59x6)	357 (21x17)	375 (25x15)	385 (35x11)	408 (51x8)
Output Speed RPM	7.54	6.86	6.87	6.36	6.25	6.06	5.72	5.56	5.38	5.09	4.94	4.90	4.67	4.55	4.29
Reduction Ratio	425 (25x17)	426 (71x6)	435 (29x15)	441 (21x21)	455 (35x13)	472 (59x8)	493 (29x17)	522 (87x6)	525 (35x15)	561 (51x11)	568 (71x8)	595 (35x17)	609 (29x21)	625 (25x25)	645 (43x15)
Output Speed RPM	4.12	4.11	4.02	3.97	3.85	3.71	3.55	3.35	3.33	3.12	3.08	2.94	2.87	2.80	2.71
Reduction Ratio	663 (51x13)	696 (87x8)	725 (29x25)	735 (35x21)	765 (51x15)	767 (59x13)	781 (71x11)	867 (51x17)	875 (35x25)	885 (59x15)	903 (43x21)	923 (71x13)	957 (87x11)	1015 (35x29)	1065 (71x15)
Output Speed RPM	2.64	2.51	2.41	2.38	2.29	2.28	2.24	2.02	2.00	1.98	1.94	1.90	1.83	1.72	1.64
Reduction Ratio	1071 (51x21)	1075 (43x25)	1131 (87x13)	1207 (71x17)	1225 (35x35)	1239 (59x21)	1275 (51x25)	1305 (87x15)	1475 (59x25)	1491 (71x21)	1505 (43x35)	1711 (59x29)	1775 (71x25)	1785 (51x35)	1827 (87x21)
Output Speed RPM	1.63	1.63	1.55	1.45	1.43	1.41	1.37	1.34	1.19	1.17	1.16	1.02	0.99	0.98	0.96
Reduction Ratio	2059 (71x29)	2175 (87x25)	2193 (51x43)	2485 (71x35)	2523 (87x29)	2601 (51x51)	3009 (59x51)	3053 (71x43)	3621 (71x51)	3741 (87x43)	4189 (71x59)	5041 (71x71)			
Output Speed RPM	0.85	0.80	0.80	0.70	0.69	0.67	0.58	0.57	0.48	0.47	0.42	0.35			

All ratios listed include double reduction Cyclo® inputs. Consult factory for available frame sizes and ratings.

This page intentionally left blank

2

How to Select

Cyclo® 6000

Selection
Tables

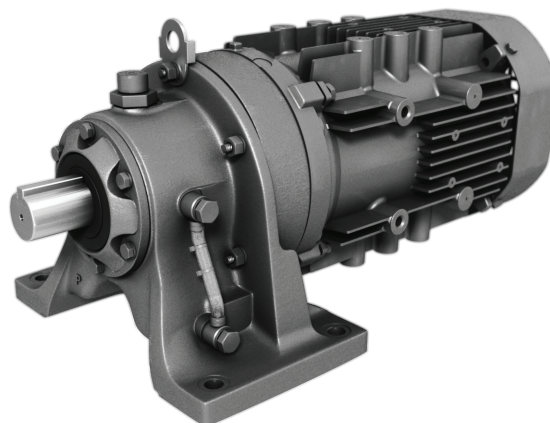



How to select a Gearmotor

Step 1: Collect data about your application

Before starting you need to know the:

- Application (e.g. Conveyor, Mixer, etc.)
- Hours of Operation per day
- Motor Horsepower (HP) and Speed (RPM)
- Desired Output Speed
- Mounting Position and Style
- Overhung or Thrust Loads
- Shaft Dimensions, inch or metric
- Electrical Specifications
- Ambient Conditions

Step 2: Select a Frame Size

2A: Find the Load Classification of your application in the AGMA Load Classification Tables on pages 2.4 and 2.5.

2B: Go to the Gearmotor Selection Table (starts on page 2.8) that corresponds to the desired Motor HP. Find the Output Speed closest to the desired output speed.

2C: Locate the Service Class in the Gearmotor Selection Table for your application and select the HP Symbol and Frame Size SELECTION that matches the HP, Output Speed, and Service Class.

Step 3: Select a Housing Style and Mounting Position

Select a housing style and mounting position from chart on page 1.8

Step 4: Verify Dimensions

Use the Dimensions information on pages 2.100 thru 2.189 to verify that the selected Frame Size is appropriate.

Step 5: Choose Options and Modifications

The following options may apply:

- **Specify Voltage** (Consult factory when application requires 575 Volt or CSA unit; dimensions may be different than those specified in Section 4).
- **Inverter Duty**
- **Special Environments**
- **Special Paint**

For available options, please visit our Configurator at www.sumitomodrive.com/configurator

Note: If desired lubrication deviates from standard, please consult factory for new power ratings. Standard Lubrication can be found in Section 4 Technical Information.

Step 6: Configure a Model Number

Go to page 2.6 to configure a model number.

Note: You will use the information you gather from the procedure on this page to Configure a Model Number.

Example page 2.3

Gearmotors

Selection Tables

Housing Style & Mounting Position

Motor HP

Frequency	Hz	50	60
Number of Poles	P		
Input Speed	RPM	1450	1750

1HP (0.75kW)

Output Speed

50Hz				60Hz				Selection					
Output Speed (RPM)	Output Torque in-lbs (N-m)	Service Factor SF	AGMA Class	Solid Shaft Overhung Load lbs (N)	Output Speed (RPM)	Output Torque in-lbs (N-m)	Service Factor SF	AGMA Class	Solid Shaft Overhung Load lbs (N)	Base Motor Power Code	Frame Size	Ratio	VFD
242	250 (28.2)	1.04	I	427 (1900)	292	206 (23.3)	1.04	I	402 (1790)	1	6085	6	•
		1.53	II	638 (2840)			1.53	II	600 (2670)	1	6090	6	•
		2.03	III	638 (2840)			2.03	III	600 (2670)	1	6095	6	•
181	332 (37.5)	1.04	I	461 (2050)	219	275 (31.1)	1.04	I	434 (1930)	1	6085	8	•
		1.53	II	710 (3160)			1.53	II	670 (2980)	1	6090	8	•
		2.03	III	710 (3160)			2.03	III	670 (2980)	1	6095	8	•
132	457 (51.6)	1.04	I	506 (2250)	159	379 (42.8)	1.04	I	479 (2130)	1	6085	11	•
		1.53	II	751 (3340)			1.53	II	751 (3340)	1	6090	11	•
		2.03	III	751 (3340)			2.03	III	751 (3340)	1	6095	11	•
112	540 (61.0)	1.04	I	542 (2410)	135	447 (50.5)	1.04	I	513 (2280)	1	6085	13	•
		1.53	II	751 (3340)			1.53	II	751 (3340)	1	6090	13	•
		2.03	III	751 (3340)			2.03	III	751 (3340)	1	6095	13	•
96.7	623 (70.4)	1.04	I	560 (2490)	117	516 (58.3)	1.04	I	528 (2350)	1	6085	15	•
		1.53	II	751 (3340)			1.53	II	751 (3340)	1	6090	15	•
		2.03	III	751 (3340)			2.03	III	751 (3340)	1	6095	15	•

Service Class

SELECTION Frame Size and HP

Dimension Pages:
Foot Mount (H) 4.2 - 4.29
V-Flange Mount (V) 4.30 - 4.43
F-Flange Mount (F) 4.44 - 4.69

For special circumstances in selecting a **Frame Size** such as:

- Overhung Load
- Thrust Loads
- Radial Loads
- Shock Loading

Consult Technical Information, see section 4

If Overhung Load is present, any Overhung Load must be checked against the capacity of the selection.



Configure a Model Number

Output Shaft Orientation

Type	Code
Horizontal [1]	H
Vertical [1]	V
Vertical Up [1]	W
Universal Direction [2]	N

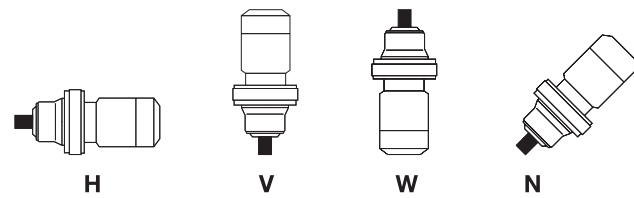

Notes:
 [1] H, V, W, units cannot change orientation in the field.
 [2]: Universal Direction (N) units are maintenance-free greased.

Housing Style

Type	Code
Foot	H
Flange	F
V-Flange	V

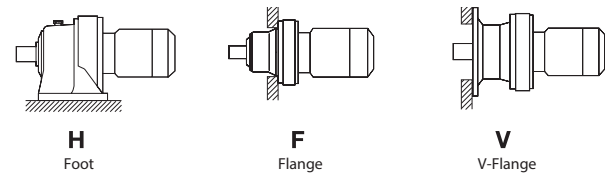

Type of Input

Motor Connection	Code
Integral Gearmotor	M
C-Face Adaptor	JM
Hollow Input Shaft	XM

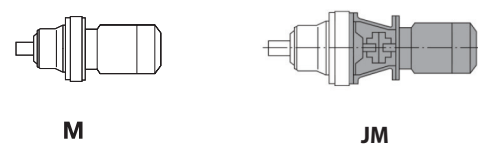

Modification (Special)

	Code
Special	S
Standard	-

Motor Capacity

HP	1/8	1/4	1/3	1/2	3/4	1	1.5	2	3	4	5	7.5	10	15	20	25	30	40	50	60	75
4P Symbol	01	02	03	05	08	1	1H	2	3	4	5	8	10	15	20	25	30	40	50	60	75

Note: For standard fractional motors (non inverter duty), no specification code suffix is required.

Shaft Specification

Shaft	Code
Metric JIS	-
Inch	Y
AGMA I	YA
AGMA II	YB
AGMA III	YC
Standard Metric DIN "G" (up to size 6125)	G
Optional Metric DIN "E" (up to size 6145)	E

Frame Size (from Selection Tables)

Brake

	Code
With Brake	B
No Brake	

C H H M - **10** - **6165** - **YB** - **EP** - **29**

C = Ratios 6:1 and greater (Cyclo Gearmotor product code)
 P = Ratios 3:1 and 5:1 (Cyclo 6000 planetary product code)
 H = Horizontal O/P
 H = Foot Mount
 M = Gearmotor
 10 = Modification (Special feature)
 6165 = Frame size
 YB = Shaft specification
 EP = Gearmotor Specification
 Brake
 29 = Ratio

Example:

CHHM10 – 6165YB – EP – 29

C – Cyclo 6000
 H – Horizontal O/P
 H – Foot Mount
 M – Gearmotor
 6165 – Frame Size
 YB – Inch Shaft, AGMA Class II
 EP – Three Phase Motor Premium Efficiency
 29 – Ratio

Specification Codes

Type	Suffix
AF Motor (Inverter Duty, 1/8 HP to 3/4 HP)	AV
Three-Phase Motor Premium Efficiency (1+ HP), IE3	EP
High Capacity Bearing, page 4.4	R1
High Capacity Bearings + Ductile Casing, page 4.5	R2
*DC Motor	DV
*CHH Type	H1 H2 H3
*Low Backlash	LB
*Single Phase Motor	SG
*Servo Motor	SV
*Torque Limiter	TL

*For technical information please contact customer service.
 Note: When there are multiple suffixes, sequence them alphabetically. Ex.: EPTL

Nominal Ratio

Selection Tables											
1HP (0.75kW)											
Frequency Hz: 50 60											
Number of Poles P: 4											
Input Speed RPM: 1450 1750											
50Hz				60Hz				Selection			
Output Speed (RPM)	Output Torque in-lbs	Output Torque (N-m)	Service Factor SF	Solid Shaft Overhung Load lbs (N)	Output Speed (RPM)	Output Torque in-lbs	Output Torque (N-m)	Service Factor SF	Solid Shaft Overhung Load lbs (N)	Motor Power Code	VFD
242	250	(28.2)	1.04 I	427 (1900)	292	206	(23.3)	1.04 I	402 (1790)	1	6085
			1.53 II	638 (2840)				1.53 II	600 (2670)	1	6090
			2.03 III	638 (2840)				2.03 III	600 (2670)	1	6095
181	332	(37.5)	1.04 I	461 (2050)	219	275	(31.1)	1.04 I	434 (1930)	1	6085
			1.53 II	710 (3160)				1.53 II	670 (2980)	1	6090

Constant Torque Speed Ranges

Page intentionally left blank.

Fractional HP Motors - 60 Hz				
Motor Power (4 - Pole)	Standard Motor		AF Motor	
	W/o Brake	With Brake	W/o Brake	With Brake
1/8 HP (0.1 kW)	2:1	2:1	10:1	10:1
1/4 HP (0.2 kW)	2:1	2:1	10:1	10:1
1/3 HP (0.25 kW)	2:1	2:1	10:1	10:1
1/2 HP (0.4 kW)	2:1	2:1	10:1	10:1
3/4 HP (0.55 kW)	2:1	2:1	10:1	10:1

Premium Efficiency Integral HP Motors - 60 Hz			
Motor Power (4 - Pole)	Standard Motor		Oversize Motor ¹
	W/o Brake	With Brake	With Brake
1 HP (0.75 kW)	10:1	10:1	Not Available
1.5 HP (1.1 kW)	10:1	5:1	10:1
2 HP (1.5 kW)	10:1	4:1	10:1
3 HP (2.2 kW)	10:1	4:1	10:1
5 HP (3.7 kW)	10:1	4:1	10:1
7.5 HP (5.5 kW)	10:1	4:1	10:1
10 HP (7.5 kW)	10:1	6:1	10:1
15 HP (11 kW)	10:1	6:1	10:1
20 HP (15 kW)	10:1	10:1	Not Available
25 HP (18.5 kW)	10:1	10:1	
30 HP (22 kW)	10:1	10:1	
40 HP (30 kW)	10:1	10:1	
50 HP (37 kW)	10:1	10:1	
60 HP (45 kW)	10:1	10:1	
75 HP (55 kW)	10:1	10:1	

¹For motor selection considerations for inverter (VFD) operation please refer to pages 4.39 and 4.40.

Selection Tables

1/8 HP
0.1 kW

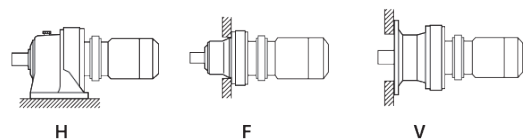

Dimension Pages:
Foot Mount (H) 2.100 - 2.129
V-Flange Mount (V) 2.130 - 2.159
F-Flange Mount (F) 2.160 - 2.189

Frequency	50 Hz	60 Hz
Input Speed	1450 RPM	1750 RPM
Number of Poles	4	

50 Hz				60 Hz				Selection									
Output Speed (RPM)	Output Torque		Service Factor ^[1]		Solid Shaft Overhung Load		Output Speed (RPM)	Output Torque		Service Factor ^[1]		Solid Shaft Overhung Load		Motor Power Code	Base Frame Size	Ratio	VFD ^[2]
	in-lbs	(N·m)	SF	AGMA Class	lbs	(N)		in-lbs	(N·m)	SF	AGMA Class	lbs	(N)				
242	33	(3.75)	2.00	III	181	(804)	292	28	(3.11)	2.00	III	170	(756)	01	6060	6	AV
			2.86	III	181	(804)				2.86	III	170	(756)				
181	44	(5.01)	2.00	III	207	(921)	219	37	(4.15)	2.00	III	195	(866)	01	6060	8	AV
			2.86	III	207	(921)				2.86	III	195	(866)				
132	61	(6.88)	2.00	III	265	(1180)	159	51	(5.70)	2.00	III	265	(1180)	01	6060	11	AV
			2.86	III	265	(1180)				2.86	III	265	(1180)				
112	72	(8.13)	2.00	III	265	(1180)	135	60	(6.74)	2.00	III	265	(1180)	01	6060	13	AV
			2.86	III	265	(1180)				2.86	III	265	(1180)				
96.7	83	(9.39)	2.00	III	265	(1180)	117	69	(7.78)	2.00	III	265	(1180)	01	6060	15	AV
			2.86	III	265	(1180)				2.86	III	265	(1180)				
85.3	94	(10.6)	2.00	III	265	(1180)	103	78	(8.81)	2.00	III	265	(1180)	01	6060	17	AV
			2.82	III	265	(1180)				2.86	III	265	(1180)				
69.0	116	(13.1)	1.83	III	265	(1180)	83.3	96	(10.9)	2.00	III	265	(1180)	01	6060	21	AV
			2.28	III	265	(1180)				2.34	III	265	(1180)				
58.0	138	(15.6)	1.10	I	265	(1180)	70.0	115	(13.0)	1.10	I	265	(1180)	01	6060	25	AV
			1.66	III	265	(1180)				1.66	III	265	(1180)				
			2.30	III	398	(1770)				2.30	III	398	(1770)				
			2.94	III	398	(1770)				2.94	III	398	(1770)				
50.0	161	(18.1)	1.10	I	265	(1180)	60.3	133	(15.0)	1.10	I	265	(1180)	01	6060	29	AV
			1.65	III	265	(1180)				1.66	III	265	(1180)				
			2.26	III	398	(1770)				2.26	III	398	(1770)				
			2.86	III	398	(1770)				2.86	III	398	(1770)				
41.4	194	(21.9)	1.10	I	265	(1180)	50.0	161	(18.1)	1.10	I	265	(1180)	01	6060	35	AV
			1.37	II	265	(1180)				1.43	II	265	(1180)				
			2.05	III	398	(1770)				2.11	III	398	(1770)				
			2.72	III	398	(1770)				2.79	III	398	(1770)				
			2.90	III	576	(2560)				3.29	III	576	(2560)				
33.7	238	(26.9)	1.12	I	265	(1180)	40.7	197	(22.3)	1.13	I	265	(1180)	01	6065	43	AV
			1.67	III	398	(1770)				1.70	III	398	(1770)				
			2.23	III	398	(1770)				2.26	III	398	(1770)				
			2.50	III	576	(2560)				2.50	III	576	(2560)				
			2.94	III	576	(2560)				2.94	III	576	(2560)				
28.4	282	(31.9)	1.00	I	398	(1770)	34.3	234	(26.4)	1.00	I	398	(1770)	01	6070	51	AV
			1.43	II	398	(1770)				1.43	II	398	(1770)				
			1.92	III	576	(2560)				1.92	III	576	(2560)				
			2.41	III	576	(2560)				2.41	III	576	(2560)				

Notes: All 1HP+ motors require EP suffix and can be used with a VFD, unless noted per column VFD [2].
 [1] Selections with service factor marked with an asterisk (*) should be limited to the identified output torque.
 [2] Variable Frequency Drive Availability:
 AV = AF-motor (AV suffix) option available (does not apply to EP motors [1HP+])
 C.F. = Consult Factory, VFD operation needs to be reviewed.

Selection Tables

1/8 HP
0.1 kW

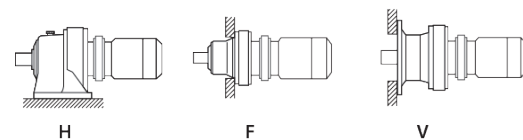

Dimension Pages:
Foot Mount (H) 2.100 - 2.129
V-Flange Mount (V) 2.130 - 2.159
F-Flange Mount (F) 2.160 - 2.189

Frequency	50 Hz	60 Hz
Input Speed	1450 RPM	1750 RPM
Number of Poles	4	

50 Hz				60 Hz				Selection									
Output Speed (RPM)	Output Torque		Service Factor ^[1]		Solid Shaft Overhung Load		Output Speed (RPM)	Output Torque		Service Factor ^[1]		Solid Shaft Overhung Load		Motor Power Code	Base Frame Size	Ratio	VFD ^[2]
	in-lbs	(N·m)	SF	AGMA Class	lbs	(N)		in-lbs	(N·m)	SF	AGMA Class	lbs	(N)				
24.6	327	(36.9)	1.00	I	398	(1770)	29.7	271	(30.6)	1.00	I	398	(1770)	01	6070	59	AV
			1.36	II	398	(1770)				1.36	II	398	(1770)				
			1.85	III	576	(2560)				1.85	III	576	(2560)				
			2.34	III	576	(2560)				2.34	III	576	(2560)				
20.4	393	(44.4)	1.20	I	576	(2560)	24.6	326	(36.8)	1.20	I	576	(2560)	01	6080	71	AV
			1.65	III	576	(2560)				1.87	III	576	(2560)				
			2.52	III	751	(3340)				2.52	III	751	(3340)				
			2.78	III	751	(3340)				3.01	III	751	(3340)				
16.7	482	(54.4)	1.21	I	576	(2560)	20.1	399	(45.1)	1.21	I	576	(2560)	01	6085	87	AV
			2.11	III	751	(3340)				2.11	III	751	(3340)				
			2.63	III	751	(3340)				3.01	III	751	(3340)				
13.9	546	(61.6)	*	-	265	(1180)	16.8	452	(51.1)	*	-	75	(336)	01	6060DA	104	AV
			*	-	265	(1180)				*	-	75	(336)				
			*	-	398	(1770)				*	-	398	(1770)				
			*	-	398	(1770)				1.17	I	398	(1770)				
			2.43	III	751	(3340)				2.94	III	751	(3340)				
12.2	659	(74.5)	1.25	I	751	(3340)	14.7	546	(61.7)	1.25	I	751	(3340)	01	6090	119	AV
			1.45	II	751	(3340)				1.51	II	751	(3340)				
12.0	635	(71.7)	*	-	265	(1180)	14.5	526	(59.4)	*	-	265	(1180)	01	6060DA	121	AV
			*	-	265	(1180)				*	-	265	(1180)				
			*	-	398	(1770)				*	-	398	(1770)				
			*	-	398	(1770)				*	-	398	(1770)				
			2.09	III	751	(3340)				2.52	III	751	(3340)				
10.1	750	(84.8)	*	-	265	(1180)	12.2	622	(70.2)	*	-	265	(1180)	01	6060DA	143	AV
			*	-	265	(1180)				*	-	265	(1180)				
			*	-	266	(1190)				*	-	398	(1770)				
			*	-	266	(1190)				*	-	398	(1770)				
			1.77	III	751	(3340)				2.14	III	751	(3340)				
8.79	866	(97.8)	*	-	265	(1180)	10.6	717	(81.0)	*	-	265	(1180)	01	6060DA	165	AV
			*	-	265	(1180)				*	-	265	(1180)				
			*	-	398	(1770)				*	-	311	(1380)				
			*	-	398	(1770)				*	-	311	(1380)				
			1.53	II	751	(3340)				1.85	III	751	(3340)				
2.04	III	751	(3340)	2.47	III	751	(3340)										
2.56	III	1210	(5400)	3.08	III	1210	(5400)										

Notes: All 1HP+ motors require EP suffix and can be used with a VFD, unless noted per column VFD [2].
 [1] Selections with service factor marked with an asterisk (*) should be limited to the identified output torque.
 [2] Variable Frequency Drive Availability:
 AV = AF-motor (AV suffix) option available (does not apply to EP motors [1HP+])
 C.F. = Consult Factory, VFD operation needs to be reviewed.

Selection Tables

1/8 HP
0.1 kW

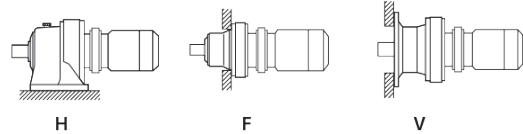

Dimension Pages:
Foot Mount (H) 2.100 - 2.129
V-Flange Mount (V) 2.130 - 2.159
F-Flange Mount (F) 2.160 - 2.189

Frequency	50 Hz	60 Hz
Input Speed	1450 RPM	1750 RPM
Number of Poles	4	

50 Hz					60 Hz					Selection							
Output Speed (RPM)	Output Torque		Service Factor ^[1]		Solid Shaft Overhung Load		Output Speed (RPM)	Output Torque		Service Factor ^[1]		Solid Shaft Overhung Load		Base			VFD ^[2]
	in-lbs	(N·m)	SF	AGMA Class	lbs	(N)		in-lbs	(N·m)	SF	AGMA Class	lbs	(N)	Motor Power Code	Frame Size	Ratio	
7.44	1020	(116)	*	-	265	(1180)	8.97	848	(95.8)	*	-	265	(1180)	01	6060DA	195	AV
			*	-	265	(1180)				*	-	265	(1180)	01	6065DA	195	AV
			*	-	398	(1770)				*	-	398	(1770)	01	6070DA	195	AV
			*	-	398	(1770)				*	-	398	(1770)	01	6075DA	195	AV
			1.30	II	751	(3340)				1.57	II	751	(3340)	01	6090DA	195	AV
			1.73	III	751	(3340)				2.09	III	751	(3340)	01	6095DA	195	AV
			2.16	III	1210	(5400)				2.61	III	1210	(5400)	01	6100DA	195	AV
			2.60	III	1210	(5400)				3.13	III	1210	(5400)	01	6105DA	195	AV
6.28	1210	(137)	*	-	265	(1180)	7.58	1000	(113)	*	-	265	(1180)	01	6060DA	231	AV
			*	-	265	(1180)				*	-	265	(1180)	01	6065DA	231	AV
			*	-	398	(1770)				*	-	398	(1770)	01	6070DA	231	AV
			*	-	398	(1770)				*	-	398	(1770)	01	6075DA	231	AV
			1.10	I	751	(3340)				1.32	II	751	(3340)	01	6090DA	231	AV
			1.46	II	751	(3340)				1.76	III	751	(3340)	01	6095DA	231	AV
			1.83	III	1210	(5400)				2.20	III	1210	(5400)	01	6100DA	231	AV
			2.19	III	1210	(5400)				2.64	III	1210	(5400)	01	6105DA	231	AV
5.31	1430	(162)	*	-	265	(1180)	6.41	1190	(134)	*	-	265	(1180)	01	6060DA	273	AV
			*	-	265	(1180)				*	-	265	(1180)	01	6065DA	273	AV
			*	-	398	(1770)				*	-	398	(1770)	01	6070DA	273	AV
			*	-	398	(1770)				*	-	398	(1770)	01	6075DA	273	AV
			1.24	I	751	(3340)				1.49	II	751	(3340)	01	6095DA	273	AV
			1.54	II	1210	(5400)				1.86	III	1210	(5400)	01	6100DA	273	AV
			1.85	III	1210	(5400)				2.24	III	1210	(5400)	01	6105DA	273	AV
			4.55	III	1210	(5400)				2.75	III	1210	(5400)	01	6120DB	319	AV
4.55	1670	(189)	*	-	265	(1180)	5.49	1390	(157)	*	-	265	(1180)	01	6060DA	319	AV
			*	-	265	(1180)				*	-	265	(1180)	01	6065DA	319	AV
			*	-	398	(1770)				*	-	398	(1770)	01	6070DA	319	AV
			*	-	398	(1770)				*	-	398	(1770)	01	6075DA	319	AV
			*	-	723	(3220)				*	-	737	(3280)	01	6090DA	319	AV
			1.06	I	723	(3220)				1.28	I	737	(3280)	01	6095DA	319	AV
			1.32	II	1210	(5400)				1.60	III	1210	(5400)	01	6100DA	319	AV
			1.59	II	1210	(5400)				1.91	III	1210	(5400)	01	6105DA	319	AV
2.75	III	2210	(9810)	3.32	III	2210	(9810)	01	6120DB	319	AV						

Selection Tables

1/8 HP
0.1 kW

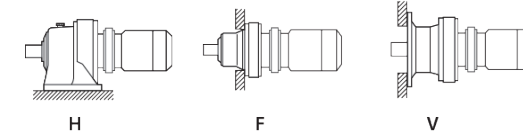

Dimension Pages:
Foot Mount (H) 2.100 - 2.129
V-Flange Mount (V) 2.130 - 2.159
F-Flange Mount (F) 2.160 - 2.189

Frequency	50 Hz	60 Hz
Input Speed	1450 RPM	1750 RPM
Number of Poles	4	

50 Hz					60 Hz					Selection							
Output Speed (RPM)	Output Torque		Service Factor ^[1]		Solid Shaft Overhung Load		Output Speed (RPM)	Output Torque		Service Factor ^[1]		Solid Shaft Overhung Load		Base			VFD ^[2]
	in-lbs	(N·m)	SF	AGMA Class	lbs	(N)		in-lbs	(N·m)	SF	AGMA Class	lbs	(N)	Motor Power Code	Frame Size	Ratio	
3.85	1980	(223)	*	-	265	(1180)	4.64	1640	(185)	*	-	265	(1180)	01	6060DA	377	AV
			*	-	265	(1180)				*	-	265	(1180)	01	6065DA	377	AV
			*	-	398	(1770)				*	-	398	(1770)	01	6070DA	377	AV
			*	-	398	(1770)				*	-	398	(1770)	01	6075DA	377	AV
			*	-	708	(3150)				*	-	725	(3230)	01	6090DA	377	AV
			*	-	708	(3150)				1.08	I	725	(3230)	01	6095DA	377	AV
			1.12	I	1210	(5400)				1.35	II	1210	(5400)	01	6100DA	377	AV
			1.34	II	1210	(5400)				1.62	III	1210	(5400)	01	6105DA	377	AV
			2.33	III	2210	(9810)				2.81	III	2210	(9810)	01	6120DB	377	AV
			2.82	III	2210	(9810)				3.40	III	2210	(9810)	01	6125DB	377	AV
3.07	2480	(280)	*	-	265	(1180)	3.70	2060	(232)	*	-	265	(1180)	01	6060DA	473	AV
			*	-	265	(1180)				*	-	265	(1180)	01	6065DA	473	AV
			*	-	358	(1590)				*	-	359	(1600)	01	6070DA	473	AV
			*	-	358	(1590)				*	-	359	(1600)	01	6075DA	473	AV
			*	-	684	(3040)				*	-	708	(3150)	01	6090DA	473	AV
			*	-	684	(3040)				*	-	708	(3150)	01	6095DA	473	AV
			1.07	I	1210	(5400)				1.29	I	1210	(5400)	01	6105DA	473	AV
			1.87	III	2210	(9810)				2.26	III	2210	(9810)	01	6120DB	473	AV
			2.25	III	2210	(9810)				2.71	III	2210	(9810)	01	6125DB	473	AV
			2.59	2930	(331)	*				-	265	(1180)	3.13	2430	(275)	*	-
*	-	357				(1590)	*	-	358	(1590)	01	6070DA				559	AV
*	-	357				(1590)	*	-	358	(1590)	01	6075DA				559	AV
*	-	656				(2920)	*	-	687	(3060)	01	6090DA				559	AV
*	-	656				(2920)	*	-	687	(3060)	01	6095DA				559	AV
*	-	984				(4380)	*	-	1210	(5400)	01	6100DA				559	AV
*	-	984				(4380)	1.09	I	1210	(5400)	01	6105DA				559	AV
1.58	II	2210				(9810)	1.91	III	2210	(9810)	01	6120DB				559	AV
1.90	III	2210				(9810)	2.29	III	2210	(9810)	01	6125DB				559	AV
2.23	3400	(385)				*	-	332	(1470)	2.70	2820	(319)				*	-
			*	-	332	(1470)	*	-	332				(1480)	01	6075DA	649	AV
			*	-	436	(1940)	*	-	662				(2950)	01	6090DA	649	AV
			*	-	506	(2250)	*	-	986				(4390)	01	6100DA	649	AV
			*	-	506	(2250)	*	-	986				(4390)	01	6105DA	649	AV
			1.36	II	2210	(9810)	1.65	III	2210				(9810)	01	6120DB	649	AV
			1.64	III	2210	(9810)	1.98	III	2210				(9810)	01	6125DB	649	AV

Notes: All 1HP+ motors require EP suffix and can be used with a VFD, unless noted per column VFD [2].

[1] Selections with service factor marked with an asterisk (*) should be limited to the identified output torque.

[2] Variable Frequency Drive Availability:

AV = AF-motor (AV suffix) option available (does not apply to EP motors [1HP+])

C.F. = Consult Factory, VFD operation needs to be reviewed.

Notes: All 1HP+ motors require EP suffix and can be used with a VFD, unless noted per column VFD [2].

[1] Selections with service factor marked with an asterisk (*) should be limited to the identified output torque.

[2] Variable Frequency Drive Availability:

AV = AF-motor (AV suffix) option available (does not apply to EP motors [1HP+])

C.F. = Consult Factory, VFD operation needs to be reviewed.

Selection Tables

1/8 HP
0.1 kW

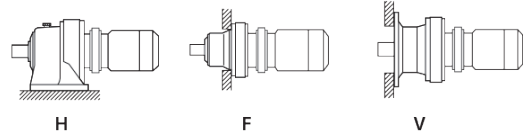

Dimension Pages:
Foot Mount (H) 2.100 - 2.129
V-Flange Mount (V) 2.130 - 2.159
F-Flange Mount (F) 2.160 - 2.189

Frequency	50 Hz	60 Hz
Input Speed	1450 RPM	1750 RPM
Number of Poles	4	

50 Hz					60 Hz					Selection							
Output Speed (RPM)	Output Torque		Service Factor ^[1]		Solid Shaft Overhung Load		Output Speed (RPM)	Output Torque		Service Factor ^[1]		Solid Shaft Overhung Load		Base			VFD ^[2]
	in-lbs	(N·m)	SF	AGMA Class	lbs	(N)		in-lbs	(N·m)	SF	AGMA Class	lbs	(N)	Motor Power Code	Frame Size	Ratio	
1.98	3840	(433)	*	-	265	(1180)	2.39	3180	(359)	*	-	265	(1180)	01	6060DA	731	AV
			*	-	265	(1180)				*	-	265	(1180)	01	6065DA	731	AV
			*	-	354	(1570)				*	-	356	(1580)	01	6070DA	731	AV
			*	-	354	(1570)				*	-	356	(1580)	01	6075DA	731	AV
			*	-	434	(1930)				*	-	487	(2170)	01	6090DA	731	AV
			*	-	434	(1930)				*	-	487	(2170)	01	6095DA	731	AV
			*	-	558	(2480)				*	-	627	(2790)	01	6100DA	731	AV
			*	-	558	(2480)				*	-	627	(2790)	01	6105DA	731	AV
			1.21	I	2210	(9810)				1.46	II	2210	(9810)	01	6120DB	731	AV
			1.45	II	2210	(9810)				1.75	III	2210	(9810)	01	6125DB	731	AV
1.72	4410	(499)	*	-	265	(1180)	2.08	3660	(413)	*	-	265	(1180)	01	6060DA	841	AV
			*	-	265	(1180)				*	-	265	(1180)	01	6065DA	841	AV
			*	-	384	(1710)				*	-	392	(1740)	01	6070DA	841	AV
			*	-	384	(1710)				*	-	392	(1740)	01	6075DA	841	AV
			*	-	420	(1870)				*	-	425	(1890)	01	6090DA	841	AV
			*	-	420	(1870)				*	-	425	(1890)	01	6095DA	841	AV
			*	-	623	(2770)				*	-	629	(2800)	01	6100DA	841	AV
			*	-	623	(2770)				*	-	629	(2800)	01	6105DA	841	AV
			1.04	I	2210	(9810)				1.26	I	2210	(9810)	01	6120DB	841	AV
			1.26	I	2210	(9810)				1.53	II	2210	(9810)	01	6125DB	841	AV
1.45	5260	(595)	*	-	327	(1460)	1.74	4360	(493)	*	-	330	(1470)	01	6070DA	1003	AV
			*	-	327	(1460)				*	-	330	(1470)	01	6075DA	1003	AV
			*	-	431	(1920)				*	-	433	(1930)	01	6090DA	1003	AV
			*	-	499	(2220)				*	-	502	(2230)	01	6100DA	1003	AV
			*	-	499	(2220)				*	-	502	(2230)	01	6105DA	1003	AV
			1.06	I	2210	(9810)				1.28	I	2210	(9810)	01	6125DB	1003	AV
1.16	6540	(739)	*	-	265	(1180)	1.40	5420	(612)	*	-	265	(1180)	01	6060DA	1247	AV
			*	-	265	(1180)				*	-	265	(1180)	01	6065DA	1247	AV
			*	-	339	(1510)				*	-	346	(1540)	01	6070DA	1247	AV
			*	-	339	(1510)				*	-	346	(1540)	01	6075DA	1247	AV
			*	-	423	(1880)				*	-	427	(1900)	01	6090DA	1247	AV
			*	-	423	(1880)				*	-	427	(1900)	01	6095DA	1247	AV
			*	-	544	(2420)				*	-	549	(2440)	01	6100DA	1247	AV
			*	-	544	(2420)				*	-	549	(2440)	01	6105DA	1247	AV
			*	-	2210	(9810)				*	-	2210	(9810)	01	6120DB	1247	AV
			*	-	2210	(9810)				1.03	I	2210	(9810)	01	6125DB	1247	AV

Notes: All 1HP+ motors require EP suffix and can be used with a VFD, unless noted per column VFD [2].
 [1] Selections with service factor marked with an asterisk (*) should be limited to the identified output torque.
 [2] Variable Frequency Drive Availability:
 AV = AF-motor (AV suffix) option available (does not apply to EP motors [1HP+])
 C.F. = Consult Factory, VFD operation needs to be reviewed.

Selection Tables

1/8 HP
0.1 kW

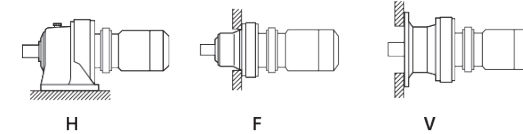

Dimension Pages:
Foot Mount (H) 2.100 - 2.129
V-Flange Mount (V) 2.130 - 2.159
F-Flange Mount (F) 2.160 - 2.189

Frequency	50 Hz	60 Hz
Input Speed	1450 RPM	1750 RPM
Number of Poles	4	

50 Hz					60 Hz					Selection							
Output Speed (RPM)	Output Torque		Service Factor ^[1]		Solid Shaft Overhung Load		Output Speed (RPM)	Output Torque		Service Factor ^[1]		Solid Shaft Overhung Load		Base			VFD ^[2]
	in-lbs	(N·m)	SF	AGMA Class	lbs	(N)		in-lbs	(N·m)	SF	AGMA Class	lbs	(N)	Motor Power Code	Frame Size	Ratio	
0.980	7760	(877)	*	-	433	(1920)	1.18	6430	(726)	*	-	435	(1940)	01	6090DA	1479	AV
			*	-	433	(1920)				*	-	435	(1940)	01	6095DA	1479	AV
			*	-	480	(2130)				*	-	483	(2150)	01	6100DA	1479	AV
			*	-	480	(2130)				*	-	483	(2150)	01	6105DA	1479	AV
			*	-	2030	(9030)				*	-	2100	(9350)	01	6120DB	1479	AV
			*	-	2030	(9030)				*	-	2100	(9350)	01	6125DB	1479	AV
0.784	9700	(1100)	*	-	265	(1180)	0.946	8040	(908)	*	-	265	(1180)	01	6060DA	1849	AV
			*	-	265	(1180)				*	-	265	(1180)	01	6065DA	1849	AV
			*	-	310	(1380)				*	-	327	(1450)	01	6070DA	1849	AV
			*	-	310	(1380)				*	-	327	(1450)	01	6075DA	1849	AV
			*	-	410	(1820)				*	-	417	(1850)	01	6090DA	1849	AV
			*	-	410	(1820)				*	-	417	(1850)	01	6095DA	1849	AV
			*	-	528	(2350)				*	-	536	(2380)	01	6100DA	1849	AV
			*	-	528	(2350)				*	-	536	(2380)	01	6105DA	1849	AV
			*	-	1380	(6120)				*	-	2210	(9810)	01	6120DB	1849	AV
			*	-	1380	(6120)				*	-	2210	(9810)	01	6125DB	1849	AV
0.702	10800	(1220)	*	-	304	(1350)	0.847	8980	(1010)	*	-	314	(1400)	01	6070DA	2065	AV
			*	-	304	(1350)				*	-	314	(1400)	01	6075DA	2065	AV
			*	-	414	(1840)				*	-	419	(1870)	01	6090DA	2065	AV
			*	-	480	(2140)				*	-	486	(2160)	01	6100DA	2065	AV
			*	-	480	(2140)				*	-	486	(2160)	01	6105DA	2065	AV
			*	-	1290	(5740)				*	-	1330	(5930)	01	6120DB	2065	AV
0.572	13300	(1500)	*	-	287	(1280)	0.690	11000	(1250)	*	-	303	(1350)	01	6070DA	2537	AV
			*	-	287	(1280)				*	-	303	(1350)	01	6075DA	2537	AV
			*	-	407	(1810)				*	-	413	(1840)	01	6090DA	2537	AV
			*	-	472	(2100)				*	-	480	(2130)	01	6100DA	2537	AV
			*	-	472	(2100)				*	-	480	(2130)	01	6105DA	2537	AV
			*	-	1290	(5730)				*	-	1290	(5740)	01	6120DB	2537	AV
0.476	16000	(1800)	*	-	416	(1850)	0.575	13200	(1500)	*	-	421	(1870)	01	6090DA	3045	AV
			*	-	416	(1850)				*	-	421	(1870)	01	6095DA	3045	AV
			*	-	461	(2050)				*	-	467	(2080)	01	6100DA	3045	AV
			*	-	461	(2050)				*	-	467	(2080)	01	6105DA	3045	AV
			*	-	1150	(5100)				*	-	1150	(5110)	01	6120DB	3045	AV
			*	-	1150	(5100)				*	-	1150	(5110)	01	6125DB	3045	AV

Notes: All 1HP+ motors require EP suffix and can be used with a VFD, unless noted per column VFD [2].
 [1] Selections with service factor marked with an asterisk (*) should be limited to the identified output torque.
 [2] Variable Frequency Drive Availability:
 AV = AF-motor (AV suffix) option available (does not apply to EP motors [1HP+])
 C.F. = Consult Factory, VFD operation needs to be reviewed.

Selection Tables

1/8 HP
0.1 kW

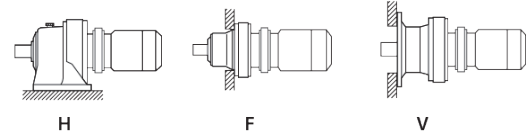

Dimension Pages:
Foot Mount (H) 2.100 - 2.129
V-Flange Mount (V) 2.130 - 2.159
F-Flange Mount (F) 2.160 - 2.189

Frequency	50 Hz	60 Hz
Input Speed	1450 RPM	1750 RPM
Number of Poles	4	

50 Hz					60 Hz					Selection							
Output Speed (RPM)	Output Torque		Service Factor ^[1]		Solid Shaft Overhung Load		Output Speed (RPM)	Output Torque		Service Factor ^[1]		Solid Shaft Overhung Load		Base			VFD ^[2]
	in-lbs	(N·m)	SF	AGMA Class	lbs	(N)		in-lbs	(N·m)	SF	AGMA Class	lbs	(N)	Motor Power Code	Frame Size	Ratio	
0.417	18300	(2060)	*	-	393	(1750)	0.503	15100	(1710)	*	-	402	(1790)	01	6090DA	3481	AV
			*	-	455	(2030)				*	-	466	(2070)	01	6100DA	3481	AV
			*	-	455	(2030)				*	-	466	(2070)	01	6105DA	3481	AV
			*	-	1280	(5710)				*	-	1290	(5730)	01	6120DB	3481	AV
			*	-	1280	(5710)				*	-	1290	(5730)	01	6125DB	3481	AV
0.327	23300	(2630)	*	-	401	(1790)	0.394	19300	(2180)	*	-	409	(1820)	01	6090DA	4437	AV
			*	-	401	(1790)				*	-	409	(1820)	01	6095DA	4437	AV
			*	-	445	(1980)				*	-	454	(2020)	01	6100DA	4437	AV
			*	-	445	(1980)				*	-	454	(2020)	01	6105DA	4437	AV
			*	-	1140	(5080)				*	-	1140	(5090)	01	6120DB	4437	AV
0.282	26900	(3040)	*	-	394	(1750)	0.341	22300	(2520)	*	-	403	(1790)	01	6090DA	5133	AV
			*	-	394	(1750)				*	-	403	(1790)	01	6095DA	5133	AV
			*	-	438	(1950)				*	-	448	(1990)	01	6100DA	5133	AV
			*	-	438	(1950)				*	-	448	(1990)	01	6105DA	5133	AV
			*	-	1140	(5070)				*	-	1140	(5090)	01	6120DB	5133	AV
0.235	32400	(3660)	*	-	1140	(5060)	0.283	26900	(3030)	*	-	1140	(5070)	01	6120DB	6177	AV
			*	-	1140	(5060)				*	-	1140	(5070)	01	6125DB	6177	AV
0.192	39700	(4490)	*	-	1130	(5040)	0.231	32900	(3720)	*	-	1140	(5060)	01	6120DB	7569	AV
			*	-	1130	(5040)				*	-	1140	(5060)	01	6125DB	7569	AV

Selection Tables

1/4 HP
0.2 kW

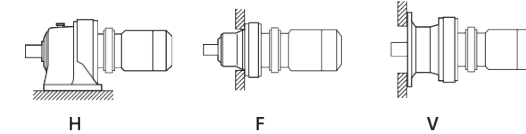

Dimension Pages:
Foot Mount (H) 2.100 - 2.129
V-Flange Mount (V) 2.130 - 2.159
F-Flange Mount (F) 2.160 - 2.189

Frequency	50 Hz	60 Hz
Input Speed	1450 RPM	1750 RPM
Number of Poles	4	

50 Hz					60 Hz					Selection							
Output Speed (RPM)	Output Torque		Service Factor ^[1]		Solid Shaft Overhung Load		Output Speed (RPM)	Output Torque		Service Factor ^[1]		Solid Shaft Overhung Load		Base			VFD ^[2]
	in-lbs	(N·m)	SF	AGMA Class	lbs	(N)		in-lbs	(N·m)	SF	AGMA Class	lbs	(N)	Motor Power Code	Frame Size	Ratio	
242	67	(7.51)	1.00	I	179	(798)	292	55	(6.22)	1.00	I	169	(751)	02	6060	6	AV
			1.43	II	179	(798)				1.43	II	169	(751)	02	6065	6	AV
			1.73	III	313	(1390)				1.73	III	294	(1310)	02	6070	6	AV
			2.03	III	313	(1390)				2.03	III	294	(1310)	02	6075	6	AV
			2.96	III	435	(1930)				2.96	III	409	(1820)	02	6080	6	AV
181	89	(10.0)	1.00	I	205	(912)	219	73	(8.29)	1.00	I	193	(859)	02	6060	8	AV
			1.43	II	205	(912)				1.43	II	193	(859)	02	6065	8	AV
			1.73	III	347	(1540)				1.73	III	326	(1450)	02	6070	8	AV
			2.03	III	347	(1540)				2.03	III	326	(1450)	02	6075	8	AV
			2.96	III	471	(2100)				2.96	III	443	(1970)	02	6080	8	AV
132	122	(13.8)	1.00	I	265	(1180)	159	101	(11.4)	1.00	I	262	(1170)	02	6060	11	AV
			1.43	II	265	(1180)				1.43	II	262	(1170)	02	6065	11	AV
			1.73	III	388	(1730)				1.73	III	366	(1630)	02	6070	11	AV
			2.03	III	388	(1730)				2.03	III	366	(1630)	02	6075	11	AV
			2.96	III	522	(2320)				2.96	III	490	(2180)	02	6080	11	AV
112	144	(16.3)	1.00	I	265	(1180)	135	119	(13.5)	1.00	I	265	(1180)	02	6060	13	AV
			1.43	II	265	(1180)				1.43	II	265	(1180)	02	6065	13	AV
			1.73	III	398	(1770)				1.73	III	387	(1720)	02	6070	13	AV
			2.03	III	398	(1770)				2.03	III	387	(1720)	02	6075	13	AV
			2.96	III	561	(2500)				2.96	III	527	(2350)	02	6080	13	AV
96.7	166	(18.8)	1.00	I	265	(1180)	117	138	(15.6)	1.00	I	265	(1180)	02	6060	15	AV
			1.43	II	265	(1180)				1.43	II	265	(1180)	02	6065	15	AV
			1.73	III	398	(1770)				1.73	III	389	(1730)	02	6070	15	AV
			2.03	III	398	(1770)				2.03	III	389	(1730)	02	6075	15	AV
			2.96	III	576	(2560)				2.96	III	545	(2420)	02	6080	15	AV
85.3	188	(21.3)	1.00	I	265	(1180)	103	156	(17.6)	1.00	I	265	(1180)	02	6060	17	AV
			1.41	II	265	(1180)				1.43	II	265	(1180)	02	6065	17	AV
			1.73	III	398	(1770)				1.73	III	398	(1770)	02	6070	17	AV
			2.03	III	398	(1770)				2.03	III	398	(1770)	02	6075	17	AV
			2.96	III	576	(2560)				2.96	III	572	(2540)	02	6080	17	AV
69.0	233	(26.3)	1.14	I	265	(1180)	83.3	193	(21.8)	1.17	I	265	(1180)	02	6065	21	AV
			1.60	III	398	(1770)				1.60	III	398	(1770)	02	6070	21	AV
			2.03	III	398	(1770)				2.03	III	398	(1770)	02	6075	21	AV
			2.39	III	576	(2560)				2.39	III	557	(2480)	02	6080	21	AV
			2.75	III	576	(2560)				2.75	III	557	(2480)	02	6085	21	AV

Notes: All 1HP+ motors require EP suffix and can be used with a VFD, unless noted per column VFD [2].

[1] Selections with service factor marked with an asterisk (*) should be limited to the identified output torque.

[2] Variable Frequency Drive Availability:

AV = AF-motor (AV suffix) option available (does not apply to EP motors [1HP+])

C.F. = Consult Factory, VFD operation needs to be reviewed.

Notes: All 1HP+ motors require EP suffix and can be used with a VFD, unless noted per column VFD [2].

[1] Selections with service factor marked with an asterisk (*) should be limited to the identified output torque.

[2] Variable Frequency Drive Availability:

AV = AF-motor (AV suffix) option available (does not apply to EP motors [1HP+])

C.F. = Consult Factory, VFD operation needs to be reviewed.

Selection Tables

1/4 HP
0.2 kW

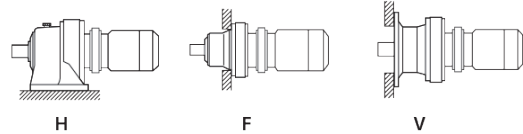

Dimension Pages:
Foot Mount (H) 2.100 - 2.129
V-Flange Mount (V) 2.130 - 2.159
F-Flange Mount (F) 2.160 - 2.189

Frequency	50 Hz	60 Hz
Input Speed	1450 RPM	1750 RPM
Number of Poles	4	

50 Hz					60 Hz					Selection							
Output Speed (RPM)	Output Torque		Service Factor ^[1]		Solid Shaft Overhung Load		Output Speed (RPM)	Output Torque		Service Factor ^[1]		Solid Shaft Overhung Load		Base			VFD ^[2]
	in-lbs	(N·m)	SF	AGMA Class	lbs	(N)		in-lbs	(N·m)	SF	AGMA Class	lbs	(N)	Motor Power Code	Frame Size	Ratio	
58.0	277	(31.3)	*	-	265	(1180)	70.0	229	(25.9)	*	-	265	(1180)	02	6065	25	AV
			1.15	I	398	(1770)				1.15	I	398	(1770)	02	6070	25	AV
			1.47	II	398	(1770)				1.47	II	398	(1770)	02	6075	25	AV
			1.70	III	576	(2560)				1.70	III	573	(2550)	02	6080	25	AV
			2.37	III	576	(2560)				2.37	III	573	(2550)	02	6085	25	AV
50.0	321	(36.3)	*	-	265	(1180)	60.3	266	(30.1)	*	-	265	(1180)	02	6065	29	AV
			1.13	I	398	(1770)				1.13	I	398	(1770)	02	6070	29	AV
			1.43	II	398	(1770)				1.43	II	398	(1770)	02	6075	29	AV
			1.70	III	576	(2560)				1.70	III	576	(2560)	02	6080	29	AV
			2.34	III	576	(2560)				2.34	III	576	(2560)	02	6085	29	AV
41.4	388	(43.8)	1.03	I	398	(1770)	50.0	321	(36.3)	1.05	I	398	(1770)	02	6070	35	AV
			1.36	II	398	(1770)				1.39	II	398	(1770)	02	6075	35	AV
			1.45	II	576	(2560)				1.64	III	576	(2560)	02	6080	35	AV
			1.64	III	576	(2560)				1.85	III	576	(2560)	02	6085	35	AV
			3.06	III	751	(3340)				3.06	III	751	(3340)	02	6090	35	AV
33.7	476	(53.8)	1.12	I	398	(1770)	40.7	395	(44.6)	1.13	I	398	(1770)	02	6075	43	AV
			1.25	I	576	(2560)				1.25	I	576	(2560)	02	6080	43	AV
			1.47	II	576	(2560)				1.47	II	576	(2560)	02	6085	43	AV
			2.18	III	751	(3340)				2.18	III	751	(3340)	02	6090	43	AV
28.4	565	(63.8)	1.21	I	576	(2560)	34.3	468	(52.9)	1.21	I	576	(2560)	02	6085	51	AV
			1.66	III	751	(3340)				1.66	III	751	(3340)	02	6090	51	AV
			2.04	III	751	(3340)				2.11	III	751	(3340)	02	6095	51	AV
			2.80	III	1210	(5400)				2.80	III	1210	(5400)	02	6100	51	AV
24.6	653	(73.8)	1.17	I	576	(2560)	29.7	541	(61.2)	1.17	I	576	(2560)	02	6085	59	AV
			1.54	II	751	(3340)				1.54	II	751	(3340)	02	6090	59	AV
			1.68	III	751	(3340)				1.86	III	751	(3340)	02	6095	59	AV
			2.58	III	1210	(5400)				2.58	III	1210	(5400)	02	6100	59	AV
			2.04	III	751	(3340)				2.11	III	751	(3340)	02	6095	51	AV
20.4	786	(88.8)	*	-	535	(2380)	24.6	652	(73.6)	*	-	564	(2510)	02	6085	71	AV
			1.26	I	751	(3340)				1.26	I	751	(3340)	02	6090	71	AV
			1.39	II	751	(3340)				1.51	II	751	(3340)	02	6095	71	AV
			2.18	III	1210	(5400)				2.18	III	1210	(5400)	02	6100	71	AV
			2.53	III	1210	(5400)				2.81	III	1210	(5400)	02	6105	71	AV
16.7	964	(109)	1.06	I	751	(3340)	20.1	798	(90.2)	1.06	I	751	(3340)	02	6090	87	AV
			1.32	II	751	(3340)				1.51	II	751	(3340)	02	6095	87	AV
			2.17	III	1210	(5400)				2.17	III	1210	(5400)	02	6100	87	AV
			2.51	III	1210	(5400)				2.83	III	1210	(5400)	02	6105	87	AV
			2.17	III	1210	(5400)				2.17	III	1210	(5400)	02	6100	87	AV

Notes: All 1HP+ motors require EP suffix and can be used with a VFD, unless noted per column VFD [2].
 [1] Selections with service factor marked with an asterisk (*) should be limited to the identified output torque.
 [2] Variable Frequency Drive Availability:
 AV = AF-motor (AV suffix) option available (does not apply to EP motors [1HP+])
 C.F. = Consult Factory, VFD operation needs to be reviewed.

Selection Tables

1/4 HP
0.2 kW

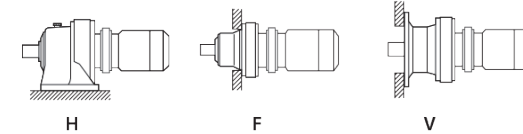

Dimension Pages:
Foot Mount (H) 2.100 - 2.129
V-Flange Mount (V) 2.130 - 2.159
F-Flange Mount (F) 2.160 - 2.189

Frequency	50 Hz	60 Hz
Input Speed	1450 RPM	1750 RPM
Number of Poles	4	

50 Hz					60 Hz					Selection							
Output Speed (RPM)	Output Torque		Service Factor ^[1]		Solid Shaft Overhung Load		Output Speed (RPM)	Output Torque		Service Factor ^[1]		Solid Shaft Overhung Load		Base			VFD ^[2]
	in-lbs	(N·m)	SF	AGMA Class	lbs	(N)		in-lbs	(N·m)	SF	AGMA Class	lbs	(N)	Motor Power Code	Frame Size	Ratio	
13.9	1090	(123)	*	-	398	(1770)	16.8	904	(102)	*	-	398	(1770)	02	6075DA	104	AV
			1.22	I	751	(3340)				1.47	II	751	(3340)	02	6090DA	104	AV
			1.47	II	751	(3340)				1.77	III	751	(3340)	02	6095DA	104	AV
			2.03	III	1210	(5400)				2.03	III	1210	(5400)	02	6100DA	104	AV
			2.03	III	1210	(5400)				2.03	III	1210	(5400)	02	6105DA	104	AV
12.2	1320	(149)	1.05	I	1210	(5400)	14.7	1090	(123)	1.05	I	1210	(5400)	02	6100	119	AV
			1.43	II	1210	(5400)				1.43	II	1210	(5400)	02	6105	119	AV
12.0	1270	(143)	1.05	I	751	(3340)	14.5	1050	(119)	1.26	I	751	(3340)	02	6090DA	121	AV
			1.12	I	751	(3340)				1.35	II	751	(3340)	02	6095DA	121	AV
			1.74	III	1210	(5400)				2.03	III	1210	(5400)	02	6100DA	121	AV
			2.03	III	1210	(5400)				2.03	III	1210	(5400)	02	6105DA	121	AV
10.1	1500	(170)	1.08	I	751	(3340)	12.2	1240	(140)	1.30	II	751	(3340)	02	6095DA	143	AV
			1.47	II	1210	(5400)				1.78	III	1210	(5400)	02	6100DA	143	AV
			1.77	III	1210	(5400)				2.03	III	1210	(5400)	02	6105DA	143	AV
			3.10	III	2210	(9810)				3.74	III	2210	(9810)	02	6120DB	143	AV
			1.08	I	751	(3340)				1.30	II	751	(3340)	02	6095DA	143	AV
8.79	1730	(196)	*	-	751	(3340)	10.6	1430	(162)	*	-	751	(3340)	02	6090DA	165	AV
			1.02	I	751	(3340)				1.23	I	751	(3340)	02	6095DA	165	AV
			1.28	I	1210	(5400)				1.54	II	1210	(5400)	02	6100DA	165	AV
			1.53	II	1210	(5400)				1.85	III	1210	(5400)	02	6105DA	165	AV
			2.68	III	2210	(9810)				3.24	III	2210	(9810)	02	6120DB	165	AV
7.44	2050	(231)	*	-	751	(3340)	8.97	1700	(192)	*	-	751	(3340)	02	6090DA	195	AV
			*	-	751	(3340)				1.04	I	751	(3340)	02	6095DA	195	AV
			1.08	I	1210	(5400)				1.31	II	1210	(5400)	02	6100DA	195	AV
			1.30	II	1210	(5400)				1.57	II	1210	(5400)	02	6105DA	195	AV
			2.27	III	2210	(9810)				2.74	III	2210	(9810)	02	6120DB	195	AV
6.28	2420	(274)	*	-	714	(3180)	7.58	2010	(227)	*	-	738	(3280)	02	6090DA	231	AV
			*	-	714	(3180)				*	-	738	(3280)	02	6095DA	231	AV
			1.10	I	1210	(5400)				1.32	II	1210	(5400)	02	6105DA	231	AV
			1.91	III	2210	(9810)				2.30	III	2210	(9810)	02	6120DB	231	AV
			2.30	III	2210	(9810)				2.78	III	2210	(9810)	02	6125DB	231	AV
2.85	III	3310	(14700)	3.44	III	3310	(14700)	02	6130DC	231	AV						

Notes: All 1HP+ motors require EP suffix and can be used with a VFD, unless noted per column VFD [2].
 [1] Selections with service factor marked with an asterisk (*) should be limited to the identified output torque.
 [2] Variable Frequency Drive Availability:
 AV = AF-motor (AV suffix) option available (does not apply to EP motors [1HP+])
 C.F. = Consult Factory, VFD operation needs to be reviewed.

Selection Tables

1/4 HP
0.2 kW

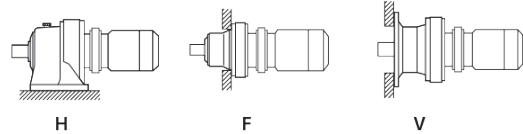

Dimension Pages:
Foot Mount (H) 2.100 - 2.129
V-Flange Mount (V) 2.130 - 2.159
F-Flange Mount (F) 2.160 - 2.189

Frequency	50 Hz	60 Hz
Input Speed	1450 RPM	1750 RPM
Number of Poles	4	

50 Hz					60 Hz					Selection													
Output Speed (RPM)	Output Torque		Service Factor ^[1]		Solid Shaft Overhung Load		Output Speed (RPM)	Output Torque		Service Factor ^[1]		Solid Shaft Overhung Load		Base			VFD ^[2]						
	in-lbs	(N·m)	SF	AGMA Class	lbs	(N)		in-lbs	(N·m)	SF	AGMA Class	lbs	(N)	Motor Power Code	Frame Size	Ratio							
5.31	2860	(324)	*	-	686	(3050)	6.41	2370	(268)	*	-	717	(3190)	02	6090DA	273	AV						
			*	-	686	(3050)				*	-	717	(3190)	02	6095DA	273	AV						
			*	-	1210	(5400)				*	-	1210	(5400)	02	6100DA	273	AV						
			*	-	1210	(5400)				1.12	I	1210	(5400)	02	6105DA	273	AV						
			1.61	III	2210	(9810)				1.95	III	2210	(9810)	02	6120DB	273	AV						
			1.95	III	2210	(9810)				2.35	III	2210	(9810)	02	6125DB	273	AV						
			2.03	III	3310	(14700)				2.03	III	3310	(14700)	02	6130DA	273	AV						
			2.41	III	3310	(14700)				2.91	III	3310	(14700)	02	6130DC	273	AV						
			2.90	III	3310	(14700)				3.51	III	3310	(14700)	02	6135DC	273	AV						
4.55	3350	(378)	*	-	427	(1900)	5.49	2770	(313)	*	-	661	(2940)	02	6095DA	319	AV						
			*	-	633	(2820)				*	-	1210	(5400)	02	6100DA	319	AV						
			*	-	633	(2820)				*	-	1210	(5400)	02	6105DA	319	AV						
			1.38	II	2210	(9810)				1.66	III	2210	(9810)	02	6120DB	319	AV						
			1.67	III	2210	(9810)				2.01	III	2210	(9810)	02	6125DB	319	AV						
			2.03	III	3310	(14700)				2.03	III	3310	(14700)	02	6130DA	319	AV						
			2.06	III	3310	(14700)				2.49	III	3310	(14700)	02	6130DC	319	AV						
			2.49	III	3310	(14700)				3.00	III	3310	(14700)	02	6135DC	319	AV						
			3.85	3960	(447)	*				-	424	(1880)	4.64	3280	(370)	*	-	294	(1310)	02	6095DA	377	AV
*	-	628				(2790)	*	-	435	(1940)	02	6100DA				377	AV						
*	-	628				(2790)	*	-	435	(1940)	02	6105DA				377	AV						
1.16	I	2210				(9810)	1.40	II	2210	(9810)	02	6120DB				377	AV						
1.41	II	2210				(9810)	1.70	III	2210	(9810)	02	6125DB				377	AV						
1.75	III	3310				(14700)	2.03	III	3310	(14700)	02	6130DA				377	AV						
2.10	III	3310				(14700)	2.54	III	3310	(14700)	02	6135DC				377	AV						
2.74	III	3600				(16000)	3.31	III	3600	(16000)	02	6140DB				377	AV						
3.07	4960	(561)				*	-	553	(2460)	3.70	4110	(465)				*	-	557	(2480)	02	6100DA	473	AV
			*	-	553	(2460)	*	-	557				(2480)	02	6105DA	473	AV						
			1.12	I	2210	(9810)	1.36	II	2210				(9810)	02	6125DB	473	AV						
			1.39	II	3310	(14700)	1.68	III	3310				(14700)	02	6130DA	473	AV						
			1.68	III	3310	(14700)	2.02	III	3310				(14700)	02	6135DC	473	AV						
			2.18	III	3600	(16000)	2.64	III	3600				(16000)	02	6140DB	473	AV						
			2.44	III	3600	(16000)	2.95	III	3600				(16000)	02	6145DB	473	AV						
			2.59	5870	(663)	*	-	548	(2440)				3.13	4860	(549)	*	-	553	(2460)	02	6105DA	559	AV
						*	-	2210	(9810)							*	-	2210	(9810)	02	6120DB	559	AV
*	-	2210				(9810)	1.15	I	2210	(9810)	02	6125DB				559	AV						
1.18	I	3310				(14700)	1.42	II	3310	(14700)	02	6130DA				559	AV						
1.42	II	3310				(14700)	1.71	III	3310	(14700)	02	6135DC				559	AV						
1.85	III	3600				(16000)	2.23	III	3600	(16000)	02	6140DB				559	AV						
2.07	III	3600				(16000)	2.50	III	3600	(16000)	02	6145DB				559	AV						

Notes: All 1HP+ motors require EP suffix and can be used with a VFD, unless noted per column VFD [2].

[1] Selections with service factor marked with an asterisk (*) should be limited to the identified output torque.

[2] Variable Frequency Drive Availability:

AV = AF-motor (AV suffix) option available (does not apply to EP motors [1HP+])

C.F. = Consult Factory, VFD operation needs to be reviewed.

Selection Tables

1/4 HP
0.2 kW

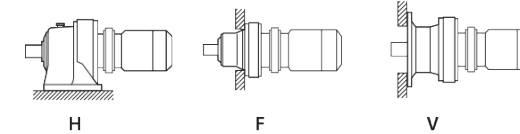

Dimension Pages:
Foot Mount (H) 2.100 - 2.129
V-Flange Mount (V) 2.130 - 2.159
F-Flange Mount (F) 2.160 - 2.189

Frequency	50 Hz	60 Hz
Input Speed	1450 RPM	1750 RPM
Number of Poles	4	

50 Hz					60 Hz					Selection							
Output Speed (RPM)	Output Torque		Service Factor ^[1]		Solid Shaft Overhung Load		Output Speed (RPM)	Output Torque		Service Factor ^[1]		Solid Shaft Overhung Load		Base			VFD ^[2]
	in-lbs	(N·m)	SF	AGMA Class	lbs	(N)		in-lbs	(N·m)	SF	AGMA Class	lbs	(N)	Motor Power Code	Frame Size	Ratio	
2.23	6810	(769)	*	-	2210	(9810)	2.70	5640	(638)	*	-	2210	(9810)	02	6120DB	649	AV
			*	-	2210	(9810)				*	-	2210	(9810)	02	6125DB	649	AV
			1.19	I	3310	(14700)				1.43	II	3310	(14700)	02	6130DA	649	AV
			1.36	II	3310	(14700)				1.65	III	3310	(14700)	02	6135DC	649	AV
			1.59	II	3600	(16000)				1.92	III	3600	(16000)	02	6140DB	649	AV
			1.78	III	3600	(16000)				2.15	III	3600	(16000)	02	6145DB	649	AV
			1.98	7670	(867)	*				-	2210	(9810)	2.39	6360	(718)	*	-
*	-	2210				(9810)	*	-	2210	(9810)	02	6125DB				731	AV
1.08	I	3310				(14700)	1.31	II	3310	(14700)	02	6135DC				731	AV
1.41	II	3600				(16000)	1.71	III	3600	(16000)	02	6140DB				731	AV
1.58	II	3600				(16000)	1.91	III	3600	(16000)	02	6145DB				731	AV
1.72	8820	(997)	*	-	1710	(7590)	2.08	7310	(826)	*	-	2210	(9810)	02	6120DA	841	AV
			*	-	1710	(7590)				*	-	2210	(9810)	02	6125DB	841	AV
			*	-	3310	(14700)				*	-	3310	(14700)	02	6130DC	841	AV
			*	-	3310	(14700)				1.14	I	3310	(14700)	02	6135DC	841	AV
			1.23	I	3600	(16000)				1.48	II	3600	(16000)	02	6140DB	841	AV
1.45	10500	(1190)	*	-	683	(3040)	1.74	8720	(985)	*	-	1730	(7700)	02	6120DA	1003	AV
			*	-	1290	(5750)				*	-	1730	(7700)	02	6125DB	1003	AV
			*	-	3310	(14700)				*	-	3310	(14700)	02	6130DC	1003	AV
			*	-	3310	(14700)				1.07	I	3310	(14700)	02	6135DC	1003	AV
			1.03	I	3600	(16000)				1.24	I	3600	(16000)	02	6140DB	1003	AV
1.16	13100	(1480)	*	-	1370	(6100)	1.40	10800	(1220)	*	-	1370	(6110)	02	6125DB	1247	AV
			*	-	3210	(14300)				*	-	3310	(14700)	02	6130DC	1247	AV
			*	-	3210	(14300)				*	-	3310	(14700)	02	6135DC	1247	AV
			*	-	3410	(15200)				1.00	I	3600	(16000)	02	6140DB	1247	AV
			*	-	3410	(15200)				1.12	I	3600	(16000)	02	6145DB	1247	AV
0.980	15500	(1750)	*	-	3290	(14600)	1.18	12900	(1450)	*	-	3310	(14700)	02	6130DC	1479	AV
			*	-	3290	(14600)				*	-	3310	(14700)	02	6135DC	1479	AV
			*	-	3600	(16000)				*	-	3600	(16000)	02	6140DB	1479	AV
			*	-	3600	(16000)				*	-	3600	(16000)	02	6145DB	1479	AV
			*	-	3600	(16000)				*	-	3600	(16000)	02	6145DB	1479	AV
0.784	19400	(2190)	*	-	2880	(12800)	0.946	16100	(1820)	*	-	3060	(13600)	02	6130DC	1849	AV
			*	-	2880	(12800)				*	-	3060	(13600)	02	6135DC	1849	AV
			*	-	2170	(9650)				*	-	2950	(13100)	02	6140DB	1849	AV
			*	-	2170	(9650)				*	-	2950	(13100)	02	6145DB	1849	AV

Notes: All 1HP+ motors require EP suffix and can be used with a VFD, unless noted per column VFD [2].

[1] Selections with service factor marked with an asterisk (*) should be limited to the identified output torque.

[2] Variable Frequency Drive Availability:

AV = AF-motor (AV suffix) option available (does not apply to EP motors [1HP+])

C.F. = Consult Factory, VFD operation needs to be reviewed.

Selection Tables

1/4 HP
0.2 kW

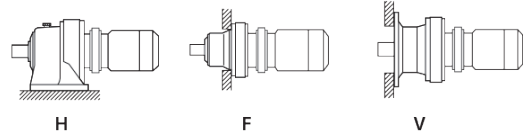

Dimension Pages:
Foot Mount (H) 2.100 - 2.129
V-Flange Mount (V) 2.130 - 2.159
F-Flange Mount (F) 2.160 - 2.189

Frequency	50 Hz	60 Hz
Input Speed	1450 RPM	1750 RPM
Number of Poles	4	

50 Hz					60 Hz					Selection							
Output Speed (RPM)	Output Torque		Service Factor ^[1]		Solid Shaft Overhung Load		Output Speed (RPM)	Output Torque		Service Factor ^[1]		Solid Shaft Overhung Load		Base			VFD ^[2]
	in-lbs	(N·m)	SF	AGMA Class	lbs	(N)		in-lbs	(N·m)	SF	AGMA Class	lbs	(N)	Motor Power Code	Frame Size	Ratio	
0.702	21700	(2450)	*	-	1970	(8760)	0.847	18000	(2030)	*	-	3130	(13900)	02	6130DC	2065	AV
			*	-	1970	(8760)				*	-	3130	(13900)	02	6135DC	2065	AV
			*	-	2180	(9700)				*	-	3600	(16000)	02	6140DB	2065	AV
			*	-	2180	(9700)				*	-	3600	(16000)	02	6145DB	2065	AV
0.572	26600	(3010)	*	-	1970	(8750)	0.690	22100	(2490)	*	-	1970	(8750)	02	6130DC	2537	AV
			*	-	1970	(8750)				*	-	1970	(8750)	02	6135DC	2537	AV
			*	-	1320	(5870)				*	-	1740	(7750)	02	6140DB	2537	AV
			*	-	1320	(5870)				*	-	1740	(7750)	02	6145DB	2537	AV
0.476	32000	(3610)	*	-	1980	(8820)	0.575	26500	(2990)	*	-	1980	(8820)	02	6130DC	3045	AV
			*	-	1980	(8820)				*	-	1980	(8820)	02	6135DC	3045	AV
			*	-	1330	(5900)				*	-	1330	(5920)	02	6140DB	3045	AV
			*	-	1330	(5900)				*	-	1330	(5920)	02	6145DB	3045	AV
0.417	36500	(4130)	*	-	1960	(8720)	0.503	30300	(3420)	*	-	1960	(8740)	02	6130DC	3481	AV
			*	-	1960	(8720)				*	-	1960	(8740)	02	6135DC	3481	AV
			*	-	1310	(5820)				*	-	1320	(5860)	02	6140DB	3481	AV
			*	-	1310	(5820)				*	-	1320	(5860)	02	6145DB	3481	AV
0.327	46600	(5260)	*	-	1980	(8800)	0.394	38600	(4360)	*	-	1980	(8810)	02	6135DC	4437	AV
			*	-	1310	(5850)				*	-	1320	(5870)	02	6140DB	4437	AV
			*	-	1310	(5850)				*	-	1320	(5870)	02	6145DB	4437	AV
0.282	53900	(6090)	*	-	1970	(8780)	0.341	44600	(5040)	*	-	1980	(8800)	02	6130DC	5133	AV
			*	-	1970	(8780)				*	-	1980	(8800)	02	6135DC	5133	AV
			*	-	1310	(5820)				*	-	1320	(5860)	02	6140DB	5133	AV
			*	-	1310	(5820)				*	-	1320	(5860)	02	6145DB	5133	AV
0.235	64800	(7320)	*	-	1970	(8770)	0.283	53700	(6070)	*	-	1980	(8790)	02	6130DC	6177	AV
			*	-	1970	(8770)				*	-	1980	(8790)	02	6135DC	6177	AV
			*	-	1300	(5780)				*	-	1310	(5820)	02	6140DB	6177	AV
			*	-	1300	(5780)				*	-	1310	(5820)	02	6145DB	6177	AV
0.192	79400	(8970)	*	-	1970	(8750)	0.231	65800	(7430)	*	-	1970	(8770)	02	6130DC	7569	AV
			*	-	1970	(8750)				*	-	1970	(8770)	02	6135DC	7569	AV
			*	-	1290	(5740)				*	-	1300	(5790)	02	6140DB	7569	AV
			*	-	1290	(5740)				*	-	1300	(5790)	02	6145DB	7569	AV

Notes: All 1HP+ motors require EP suffix and can be used with a VFD, unless noted per column VFD [2].

[1] Selections with service factor marked with an asterisk (*) should be limited to the identified output torque.

[2] Variable Frequency Drive Availability:

AV = AF-motor (AV suffix) option available (does not apply to EP motors [1HP+])

C.F. = Consult Factory, VFD operation needs to be reviewed.

Selection Tables

1/3 HP
0.25 kW

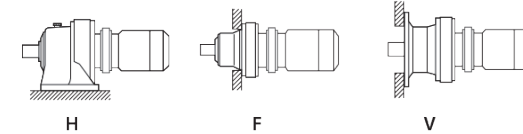

Dimension Pages:
Foot Mount (H) 2.100 - 2.129
V-Flange Mount (V) 2.130 - 2.159
F-Flange Mount (F) 2.160 - 2.189

Frequency	50 Hz	60 Hz
Input Speed	1450 RPM	1750 RPM
Number of Poles	4	

50 Hz					60 Hz					Selection							
Output Speed (RPM)	Output Torque		Service Factor ^[1]		Solid Shaft Overhung Load		Output Speed (RPM)	Output Torque		Service Factor ^[1]		Solid Shaft Overhung Load		Base			VFD ^[2]
	in-lbs	(N·m)	SF	AGMA Class	lbs	(N)		in-lbs	(N·m)	SF	AGMA Class	lbs	(N)	Motor Power Code	Frame Size	Ratio	
242	83	(9.39)	1.15	I	179	(795)	292	69	(7.78)	1.15	I	168	(749)	03	6065	6	AV
			1.39	II	312	(1390)				1.39	II	293	(1310)	03	6070	6	AV
			1.63	III	312	(1390)				1.63	III	293	(1310)	03	6075	6	AV
			2.37	III	434	(1930)				2.37	III	408	(1810)	03	6080	6	AV
181	111	(12.5)	1.15	I	204	(908)	219	92	(10.4)	1.15	I	192	(855)	03	6065	8	AV
			1.39	II	345	(1530)				1.39	II	325	(1450)	03	6070	8	AV
			1.63	III	345	(1530)				1.63	III	325	(1450)	03	6075	8	AV
			2.37	III	471	(2090)				2.37	III	442	(1970)	03	6080	8	AV
132	152	(17.2)	1.15	I	265	(1180)	159	126	(14.3)	1.15	I	261	(1160)	03	6065	11	AV
			1.39	II	386	(1720)				1.39	II	364	(1620)	03	6070	11	AV
			1.63	III	386	(1720)				1.63	III	364	(1620)	03	6075	11	AV
			2.37	III	520	(2310)				2.37	III	489	(2180)	03	6080	11	AV
112	180	(20.3)	1.15	I	265	(1180)	135	149	(16.8)	1.15	I	265	(1180)	03	6065	13	AV
			1.39	II	398	(1770)				1.39	II	384	(1710)	03	6070	13	AV
			1.63	III	398	(1770)				1.63	III	384	(1710)	03	6075	13	AV
			2.37	III	559	(2490)				2.37	III	526	(2340)	03	6080	13	AV
96.7	208	(23.5)	1.15	I	265	(1180)	117	172	(19.4)	1.15	I	265	(1180)	03	6065	15	AV
			1.39	II	398	(1770)				1.39	II	386	(1720)	03	6070	15	AV
			1.63	III	398	(1770)				1.63	III	386	(1720)	03	6075	15	AV
			2.37	III	576	(2560)				2.37	III	544	(2420)	03	6080	15	AV
85.3	235	(26.6)	1.13	I	265	(1180)	103	195	(22.0)	1.15	I	265	(1180)	03	6065	17	AV
			1.39	II	398	(1770)				1.39	II	398	(1770)	03	6070	17	AV
			1.63	III	398	(1770)				1.63	III	398	(1770)	03	6075	17	AV
			2.37	III	576	(2560)				2.37	III	570	(2540)	03	6080	17	AV
69.0	291	(32.8)	*	-	265	(1180)	83.3	241	(27.2)	*	-	265	(1180)	03	6065	21	AV
			1.28	I	398	(1770)				1.28	I	398	(1770)	03	6070	21	AV
			1.63	III	398	(1770)				1.63	III	398	(1770)	03	6075	21	AV
			1.91	III	576	(2560)				1.91	III	556	(2470)	03	6080	21	AV
			2.20	III	576	(2560)				2.20	III	556	(2470)	03	6085	21	AV
58.0	346	(39.1)	1.18	I	398	(1770)	70.0	287	(32.4)	1.18	I	398	(1770)	03	6075	25	AV
			1.36	II	576	(2560)				1.36	II	572	(2540)	03	6080	25	AV
			1.90	III	576	(2560)				1.90	III	572	(2540)	03	6085	25	AV
			2.68	III	751	(3340)				2.68	III	751	(3340)	03	6090	25	AV

Notes: All 1HP+ motors require EP suffix and can be used with a VFD, unless noted per column VFD [2].

[1] Selections with service factor marked with an asterisk (*) should be limited to the identified output torque.

[2] Variable Frequency Drive Availability:

AV = AF-motor (AV suffix) option available (does not apply to EP motors [1HP+])

C.F. = Consult Factory, VFD operation needs to be reviewed.

Selection Tables

1/3 HP
0.25 kW

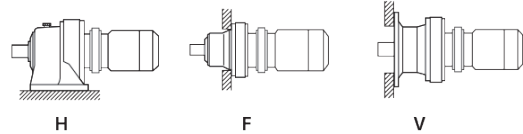

Dimension Pages:
Foot Mount (H) 2.100 - 2.129
V-Flange Mount (V) 2.130 - 2.159
F-Flange Mount (F) 2.160 - 2.189

Frequency	50 Hz	60 Hz
Input Speed	1450 RPM	1750 RPM
Number of Poles	4	

50 Hz					60 Hz					Selection							
Output Speed (RPM)	Output Torque		Service Factor ^[1]		Solid Shaft Overhung Load		Output Speed (RPM)	Output Torque		Service Factor ^[1]		Solid Shaft Overhung Load		Base			VFD ^[2]
	in-lbs	(N·m)	SF	AGMA Class	lbs	(N)		in-lbs	(N·m)	SF	AGMA Class	lbs	(N)	Motor Power Code	Frame Size	Ratio	
41.4	485	(54.7)	1.09	I	398	(1770)	50.0	401	(45.4)	1.12	I	398	(1770)	03	6075	35	AV
			1.16	I	576	(2560)				1.31	II	576	(2560)	03	6080	35	AV
			1.31	II	576	(2560)				1.48	II	576	(2560)	03	6085	35	AV
			2.45	III	751	(3340)				2.45	III	751	(3340)	03	6090	35	AV
33.7	595	(67.3)	*	-	336	(1500)	40.7	493	(55.7)	*	-	392	(1740)	03	6075	43	AV
			1.00	I	576	(2560)				1.00	I	576	(2560)	03	6080	43	AV
			1.18	I	576	(2560)				1.18	I	576	(2560)	03	6085	43	AV
			1.74	III	751	(3340)				1.74	III	751	(3340)	03	6090	43	AV
28.4	706	(79.8)	*	-	559	(2490)	34.3	585	(66.1)	*	-	576	(2560)	03	6085	51	AV
			1.33	II	751	(3340)				1.33	II	751	(3340)	03	6090	51	AV
			1.63	III	751	(3340)				1.69	III	751	(3340)	03	6095	51	AV
			2.24	III	1210	(5400)				2.24	III	1210	(5400)	03	6100	51	AV
24.6	817	(92.3)	*	-	538	(2390)	29.7	677	(76.5)	*	-	571	(2540)	03	6085	59	AV
			1.24	I	751	(3340)				1.24	I	751	(3340)	03	6090	59	AV
			1.34	II	751	(3340)				1.49	II	751	(3340)	03	6095	59	AV
			2.06	III	1210	(5400)				2.06	III	1210	(5400)	03	6100	59	AV
20.4	983	(111)	1.01	I	751	(3340)	24.6	814	(92.0)	1.01	I	751	(3340)	03	6090	71	AV
			1.11	I	751	(3340)				1.21	I	751	(3340)	03	6095	71	AV
			1.74	III	1210	(5400)				1.74	III	1210	(5400)	03	6100	71	AV
			2.02	III	1210	(5400)				2.24	III	1210	(5400)	03	6105	71	AV
16.7	1200	(136)	1.05	I	751	(3340)	20.1	998	(113)	1.21	I	751	(3340)	03	6095	87	AV
			1.73	III	1210	(5400)				1.73	III	1210	(5400)	03	6100	87	AV
			2.01	III	1210	(5400)				2.26	III	1210	(5400)	03	6105	87	AV
13.9	1360	(154)	1.17	I	751	(3340)	16.8	1130	(128)	1.42	II	751	(3340)	03	6095DA	104	AV
			1.62	III	1210	(5400)				1.63	III	1210	(5400)	03	6100DA	104	AV
			1.63	III	1210	(5400)				1.63	III	1210	(5400)	03	6105DA	104	AV
12.2	1650	(186)	1.15	I	1210	(5400)	14.7	1370	(154)	1.15	I	1210	(5400)	03	6105	119	AV
12.0	1590	(179)	*	-	751	(3340)	14.5	1310	(149)	1.08	I	751	(3340)	03	6095DA	121	AV
			1.39	II	1210	(5400)				1.63	III	1210	(5400)	03	6100DA	121	AV
			1.63	III	1210	(5400)				1.63	III	1210	(5400)	03	6105DA	121	AV
			2.93	III	2210	(9810)				3.53	III	2210	(9810)	03	6120DB	121	AV
10.1	1880	(212)	*	-	751	(3340)	12.2	1550	(176)	*	-	751	(3340)	03	6090DA	143	AV
			*	-	751	(3340)				1.04	I	751	(3340)	03	6095DA	143	AV
			1.18	I	1210	(5400)				1.42	II	1210	(5400)	03	6100DA	143	AV
			1.42	II	1210	(5400)				1.63	III	1210	(5400)	03	6105DA	143	AV
			2.48	III	2210	(9810)				2.99	III	2210	(9810)	03	6120DB	143	AV
			2.97	III	2210	(9810)				3.59	III	2210	(9810)	03	6125DB	143	AV

Notes: All 1HP+ motors require EP suffix and can be used with a VFD, unless noted per column VFD [2].

[1] Selections with service factor marked with an asterisk (*) should be limited to the identified output torque.

[2] Variable Frequency Drive Availability:

AV = AF-motor (AV suffix) option available (does not apply to EP motors [1HP+])

C.F. = Consult Factory, VFD operation needs to be reviewed.

Selection Tables

1/3 HP
0.25 kW

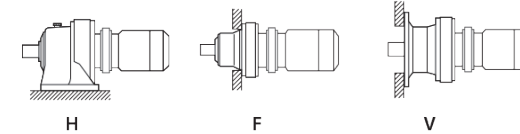

Dimension Pages:
Foot Mount (H) 2.100 - 2.129
V-Flange Mount (V) 2.130 - 2.159
F-Flange Mount (F) 2.160 - 2.189

Frequency	50 Hz	60 Hz
Input Speed	1450 RPM	1750 RPM
Number of Poles	4	

50 Hz					60 Hz					Selection							
Output Speed (RPM)	Output Torque		Service Factor ^[1]		Solid Shaft Overhung Load		Output Speed (RPM)	Output Torque		Service Factor ^[1]		Solid Shaft Overhung Load		Base			VFD ^[2]
	in-lbs	(N·m)	SF	AGMA Class	lbs	(N)		in-lbs	(N·m)	SF	AGMA Class	lbs	(N)	Motor Power Code	Frame Size	Ratio	
8.79	2160	(245)	*	-	751	(3340)	10.6	1790	(203)	*	-	751	(3340)	03	6095DA	165	AV
			1.02	I	1210	(5400)				1.23	I	1210	(5400)	03	6100DA	165	AV
			1.23	I	1210	(5400)				1.48	II	1210	(5400)	03	6105DA	165	AV
			2.15	III	2210	(9810)				2.59	III	2210	(9810)	03	6120DB	165	AV
7.44	2560	(289)	*	-	751	(3340)	8.97	2120	(239)	*	-	751	(3340)	03	6095DA	195	AV
			1.04	I	1210	(5400)				1.25	I	1210	(5400)	03	6105DA	195	AV
			1.82	III	2210	(9810)				2.19	III	2210	(9810)	03	6120DB	195	AV
			2.18	III	2210	(9810)				2.63	III	2210	(9810)	03	6125DB	195	AV
6.28	3030	(342)	*	-	1110	(4940)	7.58	2510	(284)	*	-	1210	(5400)	03	6100DA	231	AV
			*	-	1110	(4940)				1.06	I	1210	(5400)	03	6105DA	231	AV
			1.52	II	2210	(9810)				1.84	III	2210	(9810)	03	6120DB	231	AV
			1.84	III	2210	(9810)				2.22	III	2210	(9810)	03	6125DB	231	AV
5.31	3580	(405)	*	-	695	(3090)	6.41	2970	(335)	*	-	1210	(5400)	03	6105DA	273	AV
			1.29	I	2210	(9810)				1.56	II	2210	(9810)	03	6120DB	273	AV
			1.56	II	2210	(9810)				1.88	III	2210	(9810)	03	6125DB	273	AV
			1.93	III	3310	(14700)				2.33	III	3310	(14700)	03	6130DC	273	AV
4.55	4180	(473)	1.10	I	2210	(9810)	5.49	3470	(392)	1.33	II	2210	(9810)	03	6120DB	319	AV
			1.33	II	2210	(9810)				1.61	III	2210	(9810)	03	6125DB	319	AV
			1.65	III	3310	(14700)				1.99	III	3310	(14700)	03	6130DC	319	AV
			2.59	III	3600	(16000)				3.13	III	3600	(16000)	03	6140DB	319	AV
3.85	4940	(559)	1.13	I	2210	(9810)	4.64	4100	(463)	1.36	II	2210	(9810)	03	6125DB	377	AV
			1.40	II	3310	(14700)				1.69	III	3310	(14700)	03	6130DC	377	AV
			2.19	III	3600	(16000)				2.65	III	3600	(16000)	03	6140DB	377	AV
			2.45	III	3600	(16000)				2.96	III	3600	(16000)	03	6145DB	377	AV
3.07	6200	(701)	*	-	2210	(9810)	3.70	5140	(581)	*	-	2210	(9810)	03	6120DB	473	AV
			*	-	2210	(9810)				1.08	I	2210	(9810)	03	6125DB	473	AV
			1.11	I	3310	(14700)				1.34	II	3310	(14700)	03	6130DC	473	AV
			1.75	III	3600	(16000)				2.11	III	3600	(16000)	03	6140DB	473	AV
2.59	7330	(828)	*	-	2210	(9810)	3.13	6070	(686)	*	-	2210	(9810)	03	6125DB	559	AV
			*	-	3310	(14700)				1.14	I	3310	(14700)	03	6130DC	559	AV
			1.48	II	3600	(16000)				1.78	III	3600	(16000)	03	6140DB	559	AV
			1.65	III	3600	(16000)				2.00	III	3600	(16000)	03	6145DB	559	AV

Notes: All 1HP+ motors require EP suffix and can be used with a VFD, unless noted per column VFD [2].

[1] Selections with service factor marked with an asterisk (*) should be limited to the identified output torque.

[2] Variable Frequency Drive Availability:

AV = AF-motor (AV suffix) option available (does not apply to EP motors [1HP+])

C.F. = Consult Factory, VFD operation needs to be reviewed.

Selection Tables

1/3 HP
0.25 kW

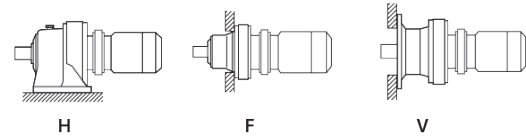

Dimension Pages:
Foot Mount (H) 2.100 - 2.129
V-Flange Mount (V) 2.130 - 2.159
F-Flange Mount (F) 2.160 - 2.189

Frequency	50 Hz	60 Hz
Input Speed	1450 RPM	1750 RPM
Number of Poles	4	

50 Hz					60 Hz					Selection							
Output Speed (RPM)	Output Torque		Service Factor ^[1]		Solid Shaft Overhung Load		Output Speed (RPM)	Output Torque		Service Factor ^[1]		Base			VFD ^[2]		
	in-lbs	(N·m)	SF	AGMA Class	lbs	(N)		in-lbs	(N·m)	SF	AGMA Class	lbs	(N)	Motor Power Code		Frame Size	Ratio
2.23	8510	(962)	*	-	3310	(14700)	2.70	7050	(797)	1.14	I	3310	(14700)	03	6130DC	649	AV
			1.27	I						3600	(16000)			03	6140DB	649	AV
			1.42	II						3600	(16000)			03	6145DB	649	AV
1.98	9590	(1080)	*	-	3310	(14700)	2.39	7940	(898)	*	-	3310	(14700)	03	6130DC	731	AV
			1.13	I						3600	(16000)			03	6140DB	731	AV
			1.26	I						3600	(16000)			03	6145DB	731	AV
1.72	11000	(1250)	*	-	3310	(14700)	2.08	9140	(1030)	*	-	3310	(14700)	03	6130DC	841	AV
			1.10	I						3600	(16000)			03	6145DB	841	AV
1.45	13200	(1490)	*	-	3310	(14700)	1.74	10900	(1230)	*	-	3310	(14700)	03	6130DC	1003	AV
			*	-						3600	(16000)			03	6140DB	1003	AV
			*	-						3600	(16000)			03	6145DB	1003	AV
1.16	16400	(1850)	*	-	2890	(12900)	1.40	13600	(1530)	*	-	3340	(14900)	03	6145DB	1247	AV

Selection Tables

1/2 HP
0.4 kW

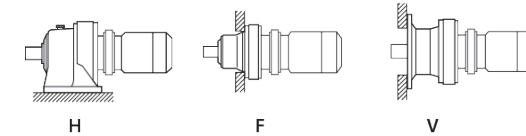

Dimension Pages:
Foot Mount (H) 2.100 - 2.129
V-Flange Mount (V) 2.130 - 2.159
F-Flange Mount (F) 2.160 - 2.189

Frequency	50 Hz	60 Hz
Input Speed	1450 RPM	1750 RPM
Number of Poles	4	

50 Hz					60 Hz					Selection							
Output Speed (RPM)	Output Torque		Service Factor ^[1]		Solid Shaft Overhung Load		Output Speed (RPM)	Output Torque		Service Factor ^[1]		Base			VFD ^[2]		
	in-lbs	(N·m)	SF	AGMA Class	lbs	(N)		in-lbs	(N·m)	SF	AGMA Class	lbs	(N)	Motor Power Code		Frame Size	Ratio
242	133	(15.0)	1.02	I	290	(1290)	292	110	(12.4)	1.02	I	290	(1290)	05	6075	6	C.F.
			1.48	II						406	(1810)			05	6080	6	AV
			1.94	III						406	(1810)			05	6085	6	AV
			2.87	III						606	(2690)			05	6090	6	AV
181	177	(20.0)	1.02	I	320	(1430)	219	147	(16.6)	1.02	I	320	(1430)	05	6075	8	C.F.
			1.48	II						440	(1960)			05	6080	8	AV
			1.94	III						440	(1960)			05	6085	8	AV
			2.87	III						675	(3000)			05	6090	8	AV
132	244	(27.5)	1.02	I	357	(1590)	159	202	(22.8)	1.02	I	357	(1590)	05	6075	11	C.F.
			1.48	II						486	(2160)			05	6080	11	AV
			1.94	III						486	(2160)			05	6085	11	AV
			2.87	III						751	(3340)			05	6090	11	AV
112	288	(32.5)	1.02	I	377	(1680)	135	239	(27.0)	1.02	I	377	(1680)	05	6075	13	C.F.
			1.48	II						522	(2320)			05	6080	13	AV
			1.94	III						522	(2320)			05	6085	13	AV
			2.87	III						751	(3340)			05	6090	13	AV
96.7	332	(37.5)	1.02	I	377	(1680)	117	275	(31.1)	1.02	I	377	(1680)	05	6075	15	C.F.
			1.48	II						539	(2400)			05	6080	15	AV
			1.94	III						539	(2400)			05	6085	15	AV
			2.87	III						751	(3340)			05	6090	15	AV
85.3	377	(42.5)	1.02	I	397	(1770)	103	312	(35.3)	1.02	I	397	(1770)	05	6075	17	C.F.
			1.48	II						565	(2510)			05	6080	17	AV
			1.94	III						565	(2510)			05	6085	17	AV
			2.87	III						751	(3340)			05	6090	17	AV
69.0	465	(52.6)	1.02	I	397	(1770)	83.3	385	(43.5)	1.02	I	397	(1770)	05	6075	21	C.F.
			1.20	I						551	(2450)			05	6080	21	AV
			1.38	II						551	(2450)			05	6085	21	AV
			1.89	III						751	(3340)			05	6090	21	AV
58.0	554	(62.6)	1.19	I	566	(2520)	70.0	459	(51.8)	1.19	I	566	(2520)	05	6085	25	AV
			1.68	III						751	(3340)			05	6090	25	AV
			2.17	III						751	(3340)			05	6095	25	AV
50.0	642	(72.6)	1.17	I	576	(2560)	60.3	532	(60.1)	1.17	I	576	(2560)	05	6085	29	AV
			1.56	II						751	(3340)			05	6090	29	AV
			1.96	III						751	(3340)			05	6095	29	AV
41.4	775	(87.6)	*	-	576	(2560)	50.0	642	(72.6)	*	-	576	(2560)	05	6085	35	AV
			1.53	II						751	(3340)			05	6090	35	AV
			1.89	III						751	(3340)			05	6095	35	AV
			2.44	III						1210	(5400)			05	6100	35	AV
			3.00	III						1210	(5400)			05	6105	35	AV

Notes: All 1HP+ motors require EP suffix and can be used with a VFD, unless noted per column VFD [2].

[1] Selections with service factor marked with an asterisk (*) should be limited to the identified output torque.

[2] Variable Frequency Drive Availability:

AV = AF-motor (AV suffix) option available (does not apply to EP motors [1HP+])

C.F. = Consult Factory, VFD operation needs to be reviewed.

Notes: All 1HP+ motors require EP suffix and can be used with a VFD, unless noted per column VFD [2].

[1] Selections with service factor marked with an asterisk (*) should be limited to the identified output torque.

[2] Variable Frequency Drive Availability:

AV = AF-motor (AV suffix) option available (does not apply to EP motors [1HP+])

C.F. = Consult Factory, VFD operation needs to be reviewed.

Selection Tables

1/2 HP
0.4 kW

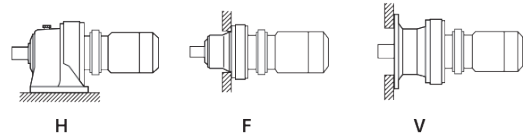

Dimension Pages:
Foot Mount (H) 2.100 - 2.129
V-Flange Mount (V) 2.130 - 2.159
F-Flange Mount (F) 2.160 - 2.189

Frequency	50 Hz	60 Hz
Input Speed	1450 RPM	1750 RPM
Number of Poles	4	

50 Hz					60 Hz					Selection							
Output Speed (RPM)	Output Torque		Service Factor ^[1]		Solid Shaft Overhung Load		Output Speed (RPM)	Output Torque		Service Factor ^[1]		Solid Shaft Overhung Load		Base			VFD ^[2]
	in-lbs	(N·m)	SF	AGMA Class	lbs	(N)		in-lbs	(N·m)	SF	AGMA Class	lbs	(N)	Motor Power Code	Frame Size	Ratio	
33.7	953	(108)	1.09	I	751	(3340)	40.7	789	(89.2)	1.09	I	751	(3340)	05	6090	43	AV
			1.51	II	751	(3340)				1.51	II	751	(3340)	05	6095	43	AV
			1.95	III	1210	(5400)				1.95	III	1210	(5400)	05	6100	43	AV
			2.71	III	1210	(5400)				2.71	III	1210	(5400)	05	6105	43	AV
28.4	1130	(128)	1.02	I	747	(3320)	34.3	936	(106)	1.05	I	751	(3340)	05	6095	51	AV
			1.40	II	1210	(5400)				1.40	II	1210	(5400)	05	6100	51	AV
			1.94	III	1210	(5400)				1.94	III	1210	(5400)	05	6105	51	AV
			2.36	III	1710	(7610)				2.36	III	1710	(7610)	05	6110	51	AV
			2.78	III	1710	(7610)				2.78	III	1710	(7610)	05	6115	51	AV
24.6	1310	(148)	*	-	741	(3300)	29.7	1080	(122)	*	-	751	(3340)	05	6095	59	AV
			1.29	I	1210	(5400)				1.29	I	1210	(5400)	05	6100	59	AV
			1.70	III	1210	(5400)				1.77	III	1210	(5400)	05	6105	59	AV
			2.15	III	1710	(7610)				2.15	III	1710	(7610)	05	6110	59	AV
			2.53	III	1710	(7610)				2.53	III	1710	(7610)	05	6115	59	AV
20.4	1570	(178)	1.09	I	1210	(5400)	24.6	1300	(147)	1.09	I	1210	(5400)	05	6100	71	AV
			1.26	I	1210	(5400)				1.40	II	1210	(5400)	05	6105	71	AV
			1.67	III	1710	(7610)				1.67	III	1710	(7610)	05	6110	71	AV
			1.89	III	1710	(7610)				1.89	III	1710	(7610)	05	6115	71	AV
			2.39	III	2210	(9810)				2.39	III	2210	(9810)	05	6120	71	AV
			2.84	III	2210	(9810)				3.00	III	2210	(9810)	05	6125	71	AV
			16.7	1930	(218)	1.08				I	1210	(5400)	20.1	1600	(180)	1.08	I
			1.26	I	1210	(5400)				1.41	II	1210	(5400)	05	6105	87	AV
			1.65	III	1710	(7610)				1.65	III	1710	(7610)	05	6110	87	AV
			1.89	III	1710	(7610)				1.89	III	1710	(7610)	05	6115	87	AV
			2.36	III	2210	(9810)				2.36	III	2210	(9810)	05	6120	87	AV
			2.57	III	2210	(9810)				2.83	III	2210	(9810)	05	6125	87	AV
13.9	2180	(247)	*	-	751	(3340)	16.8	1810	(204)	*	-	751	(3340)	05	6090DA	104	C.F.
			*	-	751	(3340)				*	-	751	(3340)	05	6095DA	104	C.F.
			1.01	I	1210	(5400)				1.02	I	1210	(5400)	05	6100DA	104	C.F.
			2.13	III	2210	(9810)				2.57	III	2210	(9810)	05	6120DB	104	AV
			2.55	III	2210	(9810)				3.08	III	2210	(9810)	05	6125DB	104	AV
12.0	2540	(287)	*	-	751	(3340)	14.5	2100	(238)	*	-	751	(3340)	05	6090DA	121	C.F.
			*	-	751	(3340)				*	-	751	(3340)	05	6095DA	121	C.F.
			1.02	I	1210	(5400)				1.02	I	1210	(5400)	05	6105DA	121	C.F.
			1.83	III	2210	(9810)				2.21	III	2210	(9810)	05	6120DB	121	AV
			2.17	III	2210	(9810)				2.62	III	2210	(9810)	05	6125DB	121	AV
			2.72	III	3310	(14700)				3.28	III	3310	(14700)	05	6130DC	121	C.F.

Notes: All 1HP+ motors require EP suffix and can be used with a VFD, unless noted per column VFD [2].

[1] Selections with service factor marked with an asterisk (*) should be limited to the identified output torque.

[2] Variable Frequency Drive Availability:

AV = AF-motor (AV suffix) option available (does not apply to EP motors [1HP+])

C.F. = Consult Factory, VFD operation needs to be reviewed.

Selection Tables

1/2 HP
0.4 kW

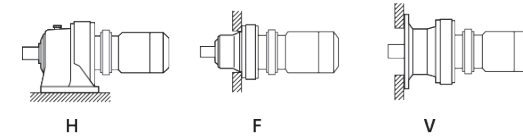

Dimension Pages:
Foot Mount (H) 2.100 - 2.129
V-Flange Mount (V) 2.130 - 2.159
F-Flange Mount (F) 2.160 - 2.189

Frequency	50 Hz	60 Hz
Input Speed	1450 RPM	1750 RPM
Number of Poles	4	

50 Hz					60 Hz					Selection							
Output Speed (RPM)	Output Torque		Service Factor ^[1]		Solid Shaft Overhung Load		Output Speed (RPM)	Output Torque		Service Factor ^[1]		Solid Shaft Overhung Load		Base			VFD ^[2]
	in-lbs	(N·m)	SF	AGMA Class	lbs	(N)		in-lbs	(N·m)	SF	AGMA Class	lbs	(N)	Motor Power Code	Frame Size	Ratio	
10.1	3000	(339)	*	-	751	(3340)	12.2	2490	(281)	*	-	751	(3340)	05	6095DA	143	C.F.
			*	-	1210	(5400)				*	-	1210	(5400)	05	6100DA	143	C.F.
			*	-	1210	(5400)				1.02	I	1210	(5400)	05	6105DA	143	C.F.
			1.55	II	2210	(9810)				1.87	III	2210	(9810)	05	6120DB	143	AV
			1.86	III	2210	(9810)				2.24	III	2210	(9810)	05	6125DB	143	AV
			2.30	III	3310	(14700)				2.78	III	3310	(14700)	05	6130DC	143	C.F.
			2.77	III	3310	(14700)				3.35	III	3310	(14700)	05	6135DC	143	C.F.
8.79	3460	(391)	*	-	744	(3310)	10.6	2870	(324)	*	-	1210	(5400)	05	6100DA	165	C.F.
			*	-	744	(3310)				*	-	1210	(5400)	05	6105DA	165	C.F.
			1.34	II	2210	(9810)				1.62	III	2210	(9810)	05	6120DB	165	AV
			1.61	III	2210	(9810)				1.94	III	2210	(9810)	05	6125DB	165	AV
			1.99	III	3310	(14700)				2.41	III	3310	(14700)	05	6130DC	165	C.F.
			2.40	III	3310	(14700)	2.90	III	3310	(14700)	05	6135DC	165	C.F.			
7.44	4090	(462)	*	-	732	(3250)	8.97	3390	(383)	*	-	746	(3320)	05	6100DA	195	C.F.
			*	-	732	(3250)				*	-	746	(3320)	05	6105DA	195	C.F.
			1.14	I	2210	(9810)				1.37	II	2210	(9810)	05	6120DB	195	AV
			1.36	II	2210	(9810)				1.64	III	2210	(9810)	05	6125DB	195	AV
			1.69	III	3310	(14700)				2.04	III	3310	(14700)	05	6130DC	195	C.F.
			2.03	III	3310	(14700)				2.45	III	3310	(14700)	05	6135DC	195	C.F.
			2.65	III	3600	(16000)				3.20	III	3600	(16000)	05	6140DB	195	AV
2.94	III	3600	(16000)	3.54	III	3600	(16000)	05	6145DB	195	AV						
6.28	4850	(548)	*	-	678	(3020)	7.58	4020	(454)	*	-	689	(3070)	05	6105DA	231	C.F.
			1.15	I	2210	(9810)				1.39	II	2210	(9810)	05	6125DB	231	AV
			1.42	II	3310	(14700)				1.72	III	3310	(14700)	05	6130DC	231	C.F.
			1.72	III	3310	(14700)				2.07	III	3310	(14700)	05	6135DC	231	C.F.
			2.24	III	3600	(16000)				2.70	III	3600	(16000)	05	6140DB	231	AV
			2.44	III	3600	(16000)	2.95	III	3600	(16000)	05	6145DB	231	AV			
5.31	5730	(647)	*	-	2210	(9810)	6.41	4750	(536)	*	-	2210	(9810)	05	6120DB	273	AV
			*	-	2210	(9810)				*	-	2210	(9810)	05	6125DB	273	AV
			1.21	I	3310	(14700)				1.45	II	3310	(14700)	05	6130DC	273	C.F.
			1.45	II	3310	(14700)				1.75	III	3310	(14700)	05	6135DC	273	C.F.
			1.89	III	3600	(16000)				2.28	III	3600	(16000)	05	6140DB	273	AV
			2.07	III	3600	(16000)				2.49	III	3600	(16000)	05	6145DB	273	AV
			2.71	III	4960	(22100)				3.27	III	4960	(22100)	05	6160DC	273	AV

Notes: All 1HP+ motors require EP suffix and can be used with a VFD, unless noted per column VFD [2].

[1] Selections with service factor marked with an asterisk (*) should be limited to the identified output torque.

[2] Variable Frequency Drive Availability:

AV = AF-motor (AV suffix) option available (does not apply to EP motors [1HP+])

C.F. = Consult Factory, VFD operation needs to be reviewed.

Selection Tables

1/2 HP
0.4 kW

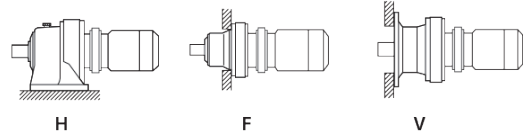

Dimension Pages:
Foot Mount (H) 2.100 - 2.129
V-Flange Mount (V) 2.130 - 2.159
F-Flange Mount (F) 2.160 - 2.189

Frequency	50 Hz	60 Hz
Input Speed	1450 RPM	1750 RPM
Number of Poles	4	

50 Hz					60 Hz					Selection													
Output Speed (RPM)	Output Torque		Service Factor ^[1]		Solid Shaft Overhung Load		Output Speed (RPM)	Output Torque		Service Factor ^[1]		Solid Shaft Overhung Load		Base			VFD ^[2]						
	in-lbs	(N·m)	SF	AGMA Class	lbs	(N)		in-lbs	(N·m)	SF	AGMA Class	lbs	(N)	Motor Power Code	Frame Size	Ratio							
4.55	6690	(756)	*	-	2210	(9810)	5.49	5550	(627)	*	-	2210	(9810)	05	6120DB	319	AV						
			*	-	2210	(9810)				1.01	I	2210	(9810)	05	6125DB	319	AV						
			1.03	I	3310	(14700)				1.24	I	3310	(14700)	05	6130DC	319	C.F.						
			1.24	I	3310	(14700)				1.50	II	3310	(14700)	05	6135DC	319	C.F.						
			1.62	III	3600	(16000)				1.95	III	3600	(16000)	05	6140DB	319	AV						
			1.81	III	3600	(16000)				2.19	III	3600	(16000)	05	6145DB	319	AV						
			2.32	III	4960	(22100)				2.80	III	4960	(22100)	05	6160DC	319	AV						
			2.78	III	4960	(22100)				3.35	III	4960	(22100)	05	6165DC	319	AV						
3.85	7910	(894)	*	-	2210	(9810)	4.64	6560	(741)	*	-	2210	(9810)	05	6120DB	377	AV						
			*	-	2210	(9810)				*	-	2210	(9810)	05	6125DB	377	AV						
			1.05	I	3310	(14700)				1.27	I	3310	(14700)	05	6135DC	377	C.F.						
			1.37	II	3600	(16000)				1.65	III	3600	(16000)	05	6140DB	377	AV						
			1.53	II	3600	(16000)				1.85	III	3600	(16000)	05	6145DB	377	AV						
			1.96	III	4960	(22100)				2.37	III	4960	(22100)	05	6160DC	377	AV						
			2.35	III	4960	(22100)				2.84	III	4960	(22100)	05	6165DC	377	AV						
			2.83	III	6630	(29500)				3.42	III	6630	(29500)	05	6170DC	377	AV						
3.07	9930	(1120)	*	-	1380	(6120)	3.70	8220	(929)	*	-	2210	(9810)	05	6125DB	473	AV						
			*	-	3310	(14700)				*	-	3310	(14700)	05	6130DC	473	C.F.						
			*	-	3310	(14700)				1.01	I	3310	(14700)	05	6135DC	473	C.F.						
			1.09	I	3600	(16000)				1.32	II	3600	(16000)	05	6140DB	473	AV						
			1.22	I	3600	(16000)				1.47	II	3600	(16000)	05	6145DB	473	AV						
			1.55	II	4960	(22100)				1.87	III	4960	(22100)	05	6160DC	473	AV						
			1.87	III	4960	(22100)				2.26	III	4960	(22100)	05	6165DC	473	AV						
			2.26	III	6630	(29500)				2.72	III	6630	(29500)	05	6170DC	473	AV						
			2.81	III	6630	(29500)				3.39	III	6630	(29500)	05	6175DC	473	AV						
			2.59	11700	(1330)	*				-	3280	(14600)	3.13	9720	(1100)	*	-	3310	(14700)	05	6130DC	559	C.F.
						*				-	3280	(14600)				*	-	3310	(14700)	05	6135DC	559	C.F.
1.03	I	3570				(15900)	1.25	I	3600	(16000)	05	6145DB				559	AV						
1.31	II	4960				(22100)	1.58	II	4960	(22100)	05	6160DC				559	AV						
1.58	II	4960				(22100)	1.91	III	4960	(22100)	05	6165DC				559	AV						
1.91	III	6630				(29500)	2.30	III	6630	(29500)	05	6170DC				559	AV						
2.38	III	6630				(29500)	2.87	III	6630	(29500)	05	6175DC				559	AV						

Notes: All 1HP+ motors require EP suffix and can be used with a VFD, unless noted per column VFD [2].
 [1] Selections with service factor marked with an asterisk (*) should be limited to the identified output torque.
 [2] Variable Frequency Drive Availability:
 AV = AF-motor (AV suffix) option available (does not apply to EP motors [1HP+])
 C.F. = Consult Factory, VFD operation needs to be reviewed.

Selection Tables

1/2 HP
0.4 kW

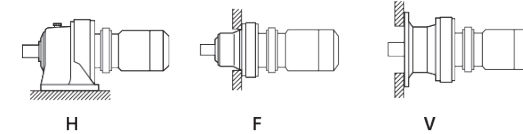

Dimension Pages:
Foot Mount (H) 2.100 - 2.129
V-Flange Mount (V) 2.130 - 2.159
F-Flange Mount (F) 2.160 - 2.189

Frequency	50 Hz	60 Hz
Input Speed	1450 RPM	1750 RPM
Number of Poles	4	

50 Hz					60 Hz					Selection													
Output Speed (RPM)	Output Torque		Service Factor ^[1]		Solid Shaft Overhung Load		Output Speed (RPM)	Output Torque		Service Factor ^[1]		Solid Shaft Overhung Load		Base			VFD ^[2]						
	in-lbs	(N·m)	SF	AGMA Class	lbs	(N)		in-lbs	(N·m)	SF	AGMA Class	lbs	(N)	Motor Power Code	Frame Size	Ratio							
2.23	13600	(1540)	*	-	3310	(14700)	2.70	11300	(1280)	*	-	3310	(14700)	05	6130DC	649	C.F.						
			*	-	3310	(14700)				*	-	3310	(14700)	05	6135DC	649	C.F.						
			*	-	3600	(16000)				*	-	3600	(16000)	05	6140DB	649	AV						
			*	-	3600	(16000)				1.07	I	3600	(16000)	05	6145DB	649	AV						
			1.14	I	4960	(22100)				1.38	II	4960	(22100)	05	6160DC	649	AV						
			1.36	II	4960	(22100)				1.65	III	4960	(22100)	05	6165DC	649	AV						
			1.64	III	6630	(29500)				1.98	III	6630	(29500)	05	6170DC	649	AV						
			2.05	III	6630	(29500)				2.47	III	6630	(29500)	05	6175DC	649	AV						
			1.98	15300	(1730)	*				-	3090	(13800)	2.39	12700	(1440)	*	-	3230	(14400)	05	6135DC	731	AV
						*				-	3070	(13700)				*	-	3450	(15400)	05	6140DB	731	AV
*	-	3070				(13700)	*	-	3450	(15400)	05	6145DB				731	AV						
1.00	I	4960				(22100)	1.21	I	4960	(22100)	05	6160DC				731	AV						
1.21	I	4960				(22100)	1.46	II	4960	(22100)	05	6165DC				731	AV						
1.46	II	6630				(29500)	1.76	III	6630	(29500)	05	6170DC				731	AV						
1.82	III	6630				(29500)	2.19	III	6630	(29500)	05	6175DC				731	AV						
1.72	17600	(1990)				*	-	2640	(11700)	2.08	14600	(1650)				*	-	3210	(14300)	05	6140DB	841	AV
			*	-	2640	(11700)	*	-	3210				(14300)	05	6145DB	841	AV						
			1.05	I	4960	(22100)	1.27	I	4960				(22100)	05	6165DC	841	C.F.						
			1.27	I	6630	(29500)	1.53	II	6630				(29500)	05	6170DC	841	C.F.						
			1.58	II	6630	(29500)	1.91	III	6630				(29500)	05	6175DC	841	C.F.						
1.45	21000	(2380)	*	-	2730	(12100)	1.74	17400	(1970)	*	-	3600	(16000)	05	6145DB	1003	AV						
			*	-	4960	(22100)				*	-	4960	(22100)	05	6160DC	1003	AV						
			*	-	4960	(22100)				*	-	4960	(22100)	05	6165DC	1003	AV						
			1.06	I	6630	(29500)				1.07	I	4960	(22100)	05	6165DC	1003	AV						
			1.32	II	6630	(29500)				1.28	I	6630	(29500)	05	6170DC	1003	AV						
			1.60	III	6630	(29500)				1.60	III	6630	(29500)	05	6175DC	1003	AV						
			1.16	26200	(2960)	*				-	4910	(21800)	1.40	21700	(2450)	*	-	4960	(22100)	05	6160DC	1247	C.F.
*	-	4910				(21800)	*	-	4960	(22100)	05	6165DC				1247	C.F.						
1.07	I	6630				(29500)	1.29	I	6630	(29500)	05	6175DC				1247	C.F.						
0.980	31000	(3510)				*	-	4400	(19600)	1.18	25700	(2910)				*	-	4610	(20500)	05	6160DC	1479	AV
			*	-	4400	(19600)	*	-	4610				(20500)	05	6165DC	1479	AV						
			*	-	6630	(29500)	*	-	6630				(29500)	05	6170DC	1479	AV						
0.784	38800	(4380)	*	-	3060	(13600)	0.946	32200	(3630)	*	-	4650	(20700)	05	6165DC	1849	AV						
			*	-	6630	(29500)				*	-	6630	(29500)	05	6170DC	1849	AV						
			*	-	6630	(29500)				*	-	6630	(29500)	05	6175DC	1849	AV						
0.702	43300	(4900)	*	-	6560	(29200)	0.847	35900	(4060)	*	-	6630	(29500)	05	6170DC	2065	AV						
			*	-	6560	(29200)				*	-	6630	(29500)	05	6175DC	2065	AV						
0.572	53200	(6020)	*	-	5390	(24000)	0.690	44100	(4980)	*	-	6530	(29100)	05	6175DC	2537	AV						

Notes: All 1HP+ motors require EP suffix and can be used with a VFD, unless noted per column VFD [2].
 [1] Selections with service factor marked with an asterisk (*) should be limited to the identified output torque.
 [2] Variable Frequency Drive Availability:
 AV = AF-motor (AV suffix) option available (does not apply to EP motors [1HP+])
 C.F. = Consult Factory, VFD operation needs to be reviewed.

Selection Tables

3/4 HP
0.55 kW

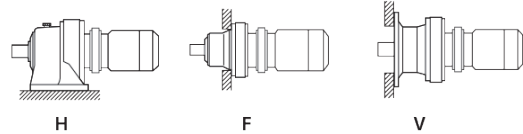

Dimension Pages:
Foot Mount (H) 2.100 - 2.129
V-Flange Mount (V) 2.130 - 2.159
F-Flange Mount (F) 2.160 - 2.189

Frequency	50 Hz	60 Hz
Input Speed	1450 RPM	1750 RPM
Number of Poles	4	

50 Hz					60 Hz					Selection							
Output Speed (RPM)	Output Torque		Service Factor ^[1]		Solid Shaft Overhung Load		Output Speed (RPM)	Output Torque		Service Factor ^[1]		Solid Shaft Overhung Load		Base			VFD ^[2]
	in-lbs	(N·m)	SF	AGMA Class	lbs	(N)		in-lbs	(N·m)	SF	AGMA Class	lbs	(N)	Motor Power Code	Frame Size	Ratio	
12.0	3490	(394)	1.33	II	2210	(9810)	14.5	2890	(327)	1.61	III	2210	(9810)	08	6120DB	121	AV
			1.58	II						1.90	III			08	6125DB	121	AV
			1.98	III						2.39	III			08	6130DC	121	C.F.
			2.38	III						2.88	III			08	6135DC	121	C.F.
			2.75	III						2.75	III			08	6140DB	121	AV
10.1	4130	(466)	1.13	I	2210	(9810)	12.2	3420	(386)	1.36	II	2210	(9810)	08	6120DB	143	AV
			1.35	II						1.63	III			08	6125DB	143	AV
			1.67	III						2.02	III			08	6130DC	143	C.F.
			2.02	III						2.43	III			08	6135DC	143	C.F.
			2.63	III						2.75	III			08	6140DB	143	AV
8.79	4760	(538)	1.17	I	2210	(9810)	10.6	3940	(446)	1.41	II	2210	(9810)	08	6125DB	165	AV
			1.45	II						1.75	III			08	6130DC	165	C.F.
			1.75	III						2.11	III			08	6135DC	165	C.F.
			2.28	III						2.75	III			08	6140DB	165	AV
			2.52	III						2.75	III			08	6145DB	165	AV
7.44	5630	(636)	*	-	2210	(9810)	8.97	4660	(527)	1.00	I	2210	(9810)	08	6120DB	195	AV
			*	-						1.20	I			08	6125DB	195	AV
			1.23	I						1.48	II			08	6130DC	195	AV
			1.48	II						1.78	III			08	6135DC	195	AV
			1.93	III						2.33	III			08	6140DB	195	AV
6.28	6670	(753)	*	-	2210	(9810)	7.58	5520	(624)	*	-	2210	(9810)	08	6120DB	231	AV
			*	-						1.01	I			08	6125DB	231	AV
			1.04	I						1.25	I			08	6130DC	231	C.F.
			1.25	I						1.51	II			08	6135DC	231	C.F.
			1.63	III						1.96	III			08	6140DB	231	AV
5.31	7880	(890)	1.06	I	3310	(14700)	6.41	6530	(737)	1.27	I	3310	(14700)	08	6135DC	273	AV
			1.38	II						1.66	III			08	6140DB	273	AV
			1.50	II						1.81	III			08	6145DB	273	AV
			1.97	III						2.38	III			08	6160DC	273	AV
			2.36	III						2.85	III			08	6165DC	273	AV
			1.06	I	3310	(14700)	6.41	6530	(737)	1.27	I	3310	(14700)	08	6135DC	273	AV
			1.38	II						1.66	III			08	6140DB	273	AV
			1.50	II						1.81	III			08	6145DB	273	AV
			1.97	III						2.38	III			08	6160DC	273	AV
			2.36	III						2.85	III			08	6165DC	273	AV

Notes: All 1HP+ motors require EP suffix and can be used with a VFD, unless noted per column VFD [2].

[1] Selections with service factor marked with an asterisk (*) should be limited to the identified output torque.

[2] Variable Frequency Drive Availability:

AV = AF-motor (AV suffix) option available (does not apply to EP motors [1HP+])

C.F. = Consult Factory, VFD operation needs to be reviewed.

Selection Tables

3/4 HP
0.55 kW

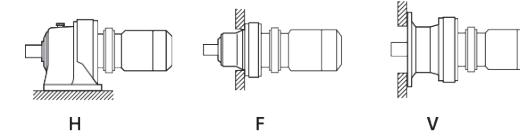

Dimension Pages:
Foot Mount (H) 2.100 - 2.129
V-Flange Mount (V) 2.130 - 2.159
F-Flange Mount (F) 2.160 - 2.189

Frequency	50 Hz	60 Hz
Input Speed	1450 RPM	1750 RPM
Number of Poles	4	

50 Hz					60 Hz					Selection							
Output Speed (RPM)	Output Torque		Service Factor ^[1]		Solid Shaft Overhung Load		Output Speed (RPM)	Output Torque		Service Factor ^[1]		Solid Shaft Overhung Load		Base			VFD ^[2]
	in-lbs	(N·m)	SF	AGMA Class	lbs	(N)		in-lbs	(N·m)	SF	AGMA Class	lbs	(N)	Motor Power Code	Frame Size	Ratio	
4.55	9200	(1040)	*	-	2210	(9810)	5.49	7630	(862)	*	-	2210	(9810)	08	6125DB	319	AV
			*	-						3310	(14700)			08	6130DC	319	C.F.
			*	-						3310	(14700)			08	6135DC	319	C.F.
			1.09	I						3310	(14700)			08	6140DB	319	AV
			1.42	II						3600	(16000)			08	6145DB	319	AV
3.85	10900	(1230)	*	-	3310	(14700)	4.64	9010	(1020)	*	-	3310	(14700)	08	6130DC	377	AV
			*	-						3310	(14700)			08	6135DC	377	AV
			1.00	I						3600	(16000)			08	6140DB	377	AV
			1.11	I						3600	(16000)			08	6145DB	377	AV
			1.43	II						4960	(22100)			08	6160DC	377	AV
3.07	13600	(1540)	*	-	3180	(14200)	3.70	11300	(1280)	*	-	3310	(14700)	08	6135DC	473	C.F.
			*	-						3330	(14800)			08	6140DB	473	AV
			*	-						3330	(14800)			08	6145DB	473	AV
			1.07	I						3590	(16000)			08	6160DC	473	C.F.
			1.36	II						4960	(22100)			08	6165DC	473	C.F.
2.59	16100	(1820)	*	-	2930	(13100)	3.13	13400	(1510)	*	-	3370	(15000)	08	6140DB	559	AV
			*	-						2930	(13100)			08	6145DB	559	AV
			1.15	I						4960	(22100)			08	6165DC	559	AV
			1.39	II						6630	(29500)			08	6170DC	559	AV
			1.73	III						6630	(29500)			08	6175DC	559	AV
2.23	18700	(2120)	*	-	3600	(16000)	2.70	15500	(1750)	*	-	3600	(16000)	08	6145DB	649	AV
			*	-						4960	(22100)			08	6160DC	649	C.F.
			*	-						4960	(22100)			08	6165DC	649	C.F.
			1.20	I						6630	(29500)			08	6170DC	649	C.F.
			1.49	II						6630	(29500)			08	6175DC	649	C.F.
1.98	21100	(2380)	*	-	4960	(22100)	2.39	17500	(1970)	*	-	4960	(22100)	08	6160DC	731	AV
			*	-						4960	(22100)			08	6165DC	731	AV
			1.06	I						6630	(29500)			08	6170DC	731	AV
			1.28	I						6630	(29500)			08	6170DC	731	AV
			1.60	III						6630	(29500)			08	6175DC	731	AV

Notes: All 1HP+ motors require EP suffix and can be used with a VFD, unless noted per column VFD [2].

[1] Selections with service factor marked with an asterisk (*) should be limited to the identified output torque.

[2] Variable Frequency Drive Availability:

AV = AF-motor (AV suffix) option available (does not apply to EP motors [1HP+])

C.F. = Consult Factory, VFD operation needs to be reviewed.

Selection Tables

3/4 HP
0.55 kW

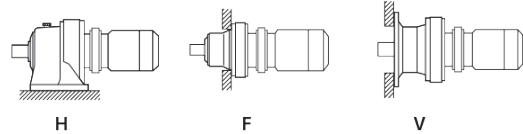

Dimension Pages:
Foot Mount (H) 2.100 - 2.129
V-Flange Mount (V) 2.130 - 2.159
F-Flange Mount (F) 2.160 - 2.189

Frequency	50 Hz	60 Hz
Input Speed	1450 RPM	1750 RPM
Number of Poles	4	

50 Hz					60 Hz					Selection							
Output Speed (RPM)	Output Torque		Service Factor ^[1]		Solid Shaft Overhung Load		Output Speed (RPM)	Output Torque		Service Factor ^[1]		Base			VFD ^[2]		
	in-lbs	(N·m)	SF	AGMA Class	lbs	(N)		in-lbs	(N·m)	SF	AGMA Class	Motor Power Code	Frame Size	Ratio			
1.72	24300	(2740)	*	-	4960	(22100)	2.08	20100	(2270)	*	-	4960	(22100)	08	6160DC	841	AV
			*	-	4960	(22100)				*	-	4960	(22100)	08	6165DC	841	AV
			1.15	I	6630	(29500)				1.39	II	6630	(29500)	08	6175DC	841	AV
1.45	28900	(3270)	*	-	4960	(22100)	1.74	24000	(2710)	*	-	4960	(22100)	08	6165DC	1003	AV
			*	-	6630	(29500)				*	-	6630	(29500)	08	6170DC	1003	AV
			*	-	6630	(29500)				1.16	I	6630	(29500)	08	6175DC	1003	AV
1.16	36000	(4070)	*	-	6630	(29500)	1.40	29800	(3370)	*	-	6630	(29500)	08	6170DC	1247	AV
			*	-	6630	(29500)				*	-	6630	(29500)	08	6175DC	1247	AV
0.980	42700	(4820)	*	-	6480	(28800)	1.18	35400	(4000)	*	-	6630	(29500)	08	6175DC	1479	AV

Selection Tables

1 HP
0.75 kW

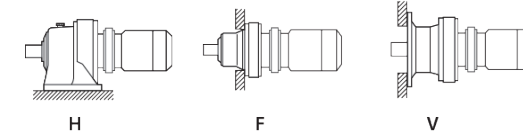

Dimension Pages:
Foot Mount (H) 2.100 - 2.129
V-Flange Mount (V) 2.130 - 2.159
F-Flange Mount (F) 2.160 - 2.189

Frequency	50 Hz	60 Hz
Input Speed	1450 RPM	1750 RPM
Number of Poles	4	

50 Hz					60 Hz					Selection						
Output Speed (RPM)	Output Torque		Service Factor ^[1]		Solid Shaft Overhung Load		Output Speed (RPM)	Output Torque		Service Factor ^[1]		Base			VFD ^[2]	
	in-lbs	(N·m)	SF	AGMA Class	lbs	(N)		in-lbs	(N·m)	SF	AGMA Class	Motor Power Code	Frame Size	Ratio		
242	249	(28.2)	1.04	I	427	(1900)	292	206	(23.3)	1.04	I	402	(1790)	1	6085	6
			1.53	II	639	(2840)				1.53	II	601	(2670)	1	6090	6
			2.02	III	639	(2840)				2.02	III	601	(2670)	1	6095	6
181	332	(37.5)	1.04	I	461	(2050)	219	275	(31.1)	1.04	I	435	(1930)	1	6085	8
			1.53	II	711	(3160)				1.53	II	669	(2980)	1	6090	8
			2.02	III	711	(3160)				2.02	III	669	(2980)	1	6095	8
132	457	(51.6)	1.04	I	507	(2250)	159	379	(42.8)	1.04	I	478	(2130)	1	6085	11
			1.53	II	751	(3340)				1.53	II	751	(3340)	1	6090	11
			2.02	III	751	(3340)				2.02	III	751	(3340)	1	6095	11
112	540	(61.0)	1.04	I	543	(2410)	135	447	(50.5)	1.04	I	513	(2280)	1	6085	13
			1.53	II	751	(3340)				1.53	II	751	(3340)	1	6090	13
			2.02	III	751	(3340)				2.02	III	751	(3340)	1	6095	13
96.7	623	(70.4)	1.04	I	559	(2490)	117	516	(58.3)	1.04	I	528	(2350)	1	6085	15
			1.53	II	751	(3340)				1.53	II	751	(3340)	1	6090	15
			2.02	III	751	(3340)				2.02	III	751	(3340)	1	6095	15
85.3	706	(79.8)	1.04	I	576	(2560)	103	585	(66.1)	1.04	I	552	(2460)	1	6085	17
			1.53	II	751	(3340)				1.53	II	751	(3340)	1	6090	17
			2.02	III	751	(3340)				2.02	III	751	(3340)	1	6095	17
			2.65	III	1210	(5400)				2.65	III	1210	(5400)	1	6100	17
69.0	872	(98.5)	1.01	I	751	(3340)	83.3	723	(81.7)	1.01	I	751	(3340)	1	6090	21
			2.01	III	751	(3340)				2.02	III	751	(3340)	1	6095	21
			2.54	III	1210	(5400)				2.57	III	1210	(5400)	1	6100	21
58.0	1040	(117)	1.16	I	751	(3340)	70.0	860	(97.2)	1.16	I	751	(3340)	1	6095	25
			1.69	III	1210	(5400)				1.69	III	1210	(5400)	1	6100	25
			2.23	III	1210	(5400)				2.23	III	1210	(5400)	1	6105	25
			2.55	III	1630	(7240)				2.55	III	1530	(6810)	1	6110	25
			2.96	III	1630	(7240)				2.96	III	1530	(6810)	1	6115	25
50.0	1200	(136)	1.04	I	746	(3320)	60.3	998	(113)	1.04	I	751	(3340)	1	6095	29
			1.61	III	1210	(5400)				1.61	III	1210	(5400)	1	6100	29
			2.12	III	1210	(5400)				2.12	III	1210	(5400)	1	6105	29
			2.54	III	1670	(7410)				2.54	III	1570	(7000)	1	6110	29
			2.96	III	1670	(7410)				2.96	III	1570	(7000)	1	6115	29
41.4	1450	(164)	1.01	I	736	(3270)	50.0	1200	(136)	1.01	I	748	(3330)	1	6095	35
			1.30	II	1210	(5400)				1.30	II	1210	(5400)	1	6100	35
			1.60	III	1210	(5400)				1.60	III	1210	(5400)	1	6105	35
			2.00	III	1680	(7470)				2.00	III	1680	(7490)	1	6110	35
			2.41	III	1680	(7470)				2.41	III	1680	(7490)	1	6115	35

Notes: All 1HP+ motors require EP suffix and can be used with a VFD, unless noted per column VFD [2].

[1] Selections with service factor marked with an asterisk (*) should be limited to the identified output torque.

[2] Variable Frequency Drive Availability:

AV = AF-motor (AV suffix) option available (does not apply to EP motors [1HP+])

C.F. = Consult Factory, VFD operation needs to be reviewed.

Notes: All 1HP+ motors require EP suffix and can be used with a VFD, unless noted per column VFD [2].

[1] Selections with service factor marked with an asterisk (*) should be limited to the identified output torque.

[2] Variable Frequency Drive Availability:

AV = AF-motor (AV suffix) option available (does not apply to EP motors [1HP+])

C.F. = Consult Factory, VFD operation needs to be reviewed.

Selection Tables

1 HP
0.75 kW

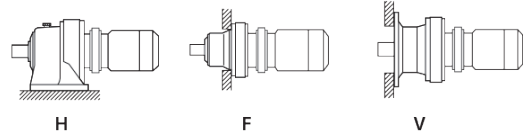

Dimension Pages:
Foot Mount (H) 2.100 - 2.129
V-Flange Mount (V) 2.130 - 2.159
F-Flange Mount (F) 2.160 - 2.189

Frequency	50 Hz	60 Hz
Input Speed	1450 RPM	1750 RPM
Number of Poles	4	

50 Hz					60 Hz					Selection							
Output Speed (RPM)	Output Torque		Service Factor ^[1]		Solid Shaft Overhung Load		Output Speed (RPM)	Output Torque		Service Factor ^[1]		Solid Shaft Overhung Load		Base			VFD ^[2]
	in-lbs	(N·m)	SF	AGMA Class	lbs	(N)		in-lbs	(N·m)	SF	AGMA Class	lbs	(N)	Motor Power Code	Frame Size	Ratio	
33.7	1790	(202)	0.80	-	722	(3210)	40.7	1480	(167)	0.80	-	738	(3280)	1	6095	43	
			1.04	I	1210	(5400)				1.04	I	1210	(5400)	1	6100	43	
			1.45	II	1210	(5400)				1.45	II	1210	(5400)	1	6105	43	
			1.73	III	1710	(7610)				1.73	III	1710	(7610)	1	6110	43	
			2.02	III	1710	(7610)				2.02	III	1710	(7610)	1	6115	43	
			2.55	III	2210	(9810)				2.55	III	2170	(9640)	1	6120	43	
28.4	2120	(239)	1.03	I	1210	(5400)	34.3	1760	(198)	1.03	I	1210	(5390)	1	6105	51	
			1.26	I	1710	(7610)				1.26	I	1710	(7610)	1	6110	51	
			1.48	II	1710	(7610)				1.48	II	1710	(7610)	1	6115	51	
			2.17	III	2210	(9810)				2.29	III	2210	(9810)	1	6120	51	
			2.63	III	2210	(9810)				3.04	III	2210	(9810)	1	6125	51	
24.6	2450	(277)	0.91	-	1210	(5400)	29.7	2030	(229)	0.94	-	1210	(5370)	1	6105	59	
			1.15	I	1710	(7610)				1.15	I	1710	(7610)	1	6110	59	
			1.35	II	1710	(7610)				1.35	II	1710	(7610)	1	6115	59	
			1.74	III	2210	(9810)				1.74	III	2210	(9810)	1	6120	59	
			2.16	III	2210	(9810)				2.16	III	2210	(9810)	1	6125	59	
			2.82	III	2970	(13200)				2.91	III	2790	(12400)	1	6130	59	
20.4	2950	(333)	1.01	I	1710	(7610)	24.6	2440	(276)	1.01	I	1710	(7610)	1	6115	71	
			1.28	I	2210	(9810)				1.28	I	2210	(9810)	1	6120	71	
			1.52	II	2210	(9810)				1.60	III	2210	(9810)	1	6125	71	
			2.34	III	3140	(14000)				2.44	III	2950	(13100)	1	6130	71	
			2.70	III	3140	(14000)				2.89	III	2950	(13100)	1	6135	71	
			16.7	3610	(408)	1.01				I	1700	(7550)	20.1	2990	(338)	1.01	
1.26	I	2210				(9810)	1.26	I	2210	(9810)	1	6120				87	
1.37	II	2210				(9810)	1.51	II	2210	(9810)	1	6125				87	
1.89	III	3310				(14700)	1.89	III	3190	(14200)	1	6130				87	
2.20	III	3310				(14700)	2.55	III	3190	(14200)	1	6135				87	
2.64	III	3600				(16000)	2.64	III	3600	(16000)	1	6140				87	
2.88	III	3600				(16000)	3.31	III	3600	(16000)	1	6145				87	
13.9	4090	(462)				1.14	I	2210	(9810)	16.8	3390	(383)				1.37	II
			1.36	II	2210	(9810)	1.64	III	2210				(9810)	1	6125DB	104	
			1.69	III	3310	(14700)	2.04	III	3310				(14700)	1	6130DC	104	
			2.03	III	3310	(14700)	2.45	III	3310				(14700)	1	6135DC	104	
12.0	4760	(538)	1.16	I	2210	(9810)	14.5	3940	(446)	1.40	II	2210	(9810)	1	6125DB	121	
			1.45	II	3310	(14700)				1.75	III	3310	(14700)	1	6130DC	121	
			1.75	III	3310	(14700)				2.11	III	3310	(14700)	1	6135DC	121	

Notes: All 1HP+ motors require EP suffix and can be used with a VFD, unless noted per column VFD [2].

[1] Selections with service factor marked with an asterisk (*) should be limited to the identified output torque.

[2] Variable Frequency Drive Availability:

AV = AF-motor (AV suffix) option available (does not apply to EP motors [1HP+])

C.F. = Consult Factory, VFD operation needs to be reviewed.

Selection Tables

1 HP
0.75 kW

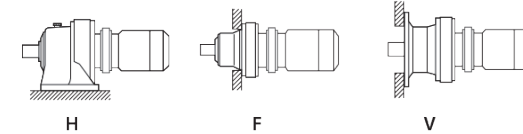

Dimension Pages:
Foot Mount (H) 2.100 - 2.129
V-Flange Mount (V) 2.130 - 2.159
F-Flange Mount (F) 2.160 - 2.189

Frequency	50 Hz	60 Hz
Input Speed	1450 RPM	1750 RPM
Number of Poles	4	

50 Hz					60 Hz					Selection							
Output Speed (RPM)	Output Torque		Service Factor ^[1]		Solid Shaft Overhung Load		Output Speed (RPM)	Output Torque		Service Factor ^[1]		Solid Shaft Overhung Load		Base			VFD ^[2]
	in-lbs	(N·m)	SF	AGMA Class	lbs	(N)		in-lbs	(N·m)	SF	AGMA Class	lbs	(N)	Motor Power Code	Frame Size	Ratio	
10.1	4650	(525)	*	-	2210	(9810)	12.2	4660	(527)	1.00	I	2210	(9810)	1	6120DB	143	
			0.99	-	2210	(9810)				1.20	I	2210	(9810)	1	6125DB	143	
			1.23	I	3310	(14700)				1.48	II	3310	(14700)	1	6130DC	143	
			1.48	II	3310	(14700)				1.78	III	3310	(14700)	1	6135DC	143	
			1.93	III	3600	(16000)				2.02	III	3600	(16000)	1	6140DB	143	
			2.02	III	3600	(16000)				2.02	III	3600	(16000)	1	6145DB	143	
8.79	4650	(525)	*	-	2210	(9810)	10.6	4650	(525)	*	-	2210	(9810)	1	6120DB	165	
			0.86	-	2210	(9810)				1.04	I	2210	(9810)	1	6125DB	165	
			1.06	I	3310	(14700)				1.28	I	3310	(14700)	1	6130DC	165	
			1.28	I	3310	(14700)				1.55	II	3310	(14700)	1	6135DC	165	
			1.67	III	3600	(16000)				2.02	III	3600	(16000)	1	6140DB	165	
			1.85	III	3600	(16000)				2.02	III	3600	(16000)	1	6145DB	165	
7.44	5580	(630)	*	-	2210	(9810)	8.97	5580	(630)	*	-	2210	(9810)	1	6125DB	195	
			1.08	I	3310	(14700)				1.31	II	3310	(14700)	1	6135DC	195	
			1.41	II	3600	(16000)				1.71	III	3600	(16000)	1	6140DB	195	
			1.57	II	3600	(16000)				1.89	III	3600	(16000)	1	6145DB	195	
			2.02	III	4960	(22100)				2.44	III	4960	(22100)	1	6160DC	195	
			2.42	III	4960	(22100)				2.92	III	4960	(22100)	1	6165DC	195	
6.28	5580	(630)	*	-	2210	(9810)	7.58	5580	(630)	*	-	2210	(9810)	1	6125DB	231	
			0.92	-	3310	(14700)				*	-	3310	(14700)	1	6130DC	231	
			0.92	-	3310	(14700)				1.10	I	3310	(14700)	1	6135DC	231	
			1.19	I	3600	(16000)				1.44	II	3600	(16000)	1	6140DB	231	
			1.30	II	3600	(16000)				1.57	II	3600	(16000)	1	6145DB	231	
			1.71	III	4960	(22100)				2.06	III	4960	(22100)	1	6160DC	231	
			2.04	III	4960	(22100)				2.47	III	4960	(22100)	1	6165DC	231	
			2.46	III	6630	(29500)				2.97	III	6630	(29500)	1	6170DC	231	
5.31	6900	(780)	*	-	3310	(14700)	6.41	6900	(780)	*	-	3310	(14700)	1	6130DC	273	
			*	-	3310	(14700)				*	-	3310	(14700)	1	6135DC	273	
			1.01	I	3600	(16000)				1.22	I	3600	(16000)	1	6140DB	273	
			1.10	I	3600	(16000)				1.33	II	3600	(16000)	1	6145DB	273	
			1.45	II	4960	(22100)				1.75	III	4960	(22100)	1	6160DC	273	
			1.73	III	4960	(22100)				2.09	III	4960	(22100)	1	6165DC	273	
			2.08	III	6630	(29500)	2.52	III	6630	(29500)	1	6170DC	273				
			2.60	III	6630	(29500)	3.13	III	6630	(29500)	1	6175DC	273				

Notes: All 1HP+ motors require EP suffix and can be used with a VFD, unless noted per column VFD [2].

[1] Selections with service factor marked with an asterisk (*) should be limited to the identified output torque.

[2] Variable Frequency Drive Availability:

AV = AF-motor (AV suffix) option available (does not apply to EP motors [1HP+])

C.F. = Consult Factory, VFD operation needs to be reviewed.

Selection Tables

1 HP
0.75 kW

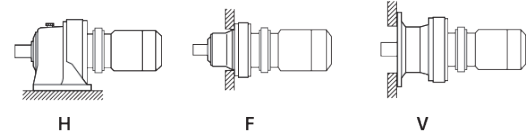

Dimension Pages:
Foot Mount (H) 2.100 - 2.129
V-Flange Mount (V) 2.130 - 2.159
F-Flange Mount (F) 2.160 - 2.189

Frequency	50 Hz	60 Hz
Input Speed	1450 RPM	1750 RPM
Number of Poles	4	

50 Hz					60 Hz					Selection			VFD ^[2]			
Output Speed (RPM)	Output Torque		Service Factor ^[1]		Solid Shaft Overhung Load		Output Speed (RPM)	Output Torque		Service Factor ^[1]		Base				
	in-lbs	(N·m)	SF	AGMA Class	lbs	(N)		in-lbs	(N·m)	SF	AGMA Class	lbs	(N)	Motor Power Code	Frame Size	Ratio
0.327	56500	(6380)	*	-	13200	(58900)	0.394	56500	(6380)	*	-	13200	(58900)	1	6190DA	4437
	70500	(7960)	*	-	13100	(58400)		70500	(7960)	*	-	13100	(58400)	1	6195DA	4437
	77500	(8760)	*	-	18900	(84100)		77500	(8760)	*	-	18900	(84100)	1	6205DA	4437
0.282	56500	(6380)	*	-	13200	(58900)	0.341	56500	(6380)	*	-	13200	(58900)	1	6190DA	5133
	70500	(7960)	*	-	13100	(58400)		70500	(7960)	*	-	13100	(58400)	1	6195DA	5133
	82300	(9300)	*	-	18900	(84100)		82300	(9300)	*	-	18900	(84100)	1	6205DA	5133
0.235	56500	(6380)	*	-	13200	(58900)	0.283	56500	(6380)	*	-	13200	(58900)	1	6190DA	6177
	70500	(7960)	*	-	13100	(58400)		70500	(7960)	*	-	13100	(58400)	1	6195DA	6177
	77500	(8760)	*	-	18900	(84100)		77500	(8760)	*	-	18900	(84100)	1	6205DA	6177
0.192	56500	(6380)	*	-	13200	(58900)	0.231	56500	(6380)	*	-	13200	(58900)	1	6190DA	7569
	70500	(7960)	*	-	13100	(58400)		70500	(7960)	*	-	13100	(58400)	1	6195DA	7569
	77500	(8760)	*	-	18900	(84100)		77500	(8760)	*	-	18900	(84100)	1	6205DA	7569

Selection Tables

1.5 HP
1.1 kW

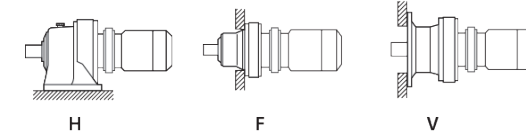

Dimension Pages:
Foot Mount (H) 2.100 - 2.129
V-Flange Mount (V) 2.130 - 2.159
F-Flange Mount (F) 2.160 - 2.189

Frequency	50 Hz	60 Hz
Input Speed	1450 RPM	1750 RPM
Number of Poles	4	

50 Hz					60 Hz					Selection			VFD ^[2]			
Output Speed (RPM)	Output Torque		Service Factor ^[1]		Solid Shaft Overhung Load		Output Speed (RPM)	Output Torque		Service Factor ^[1]		Base				
	in-lbs	(N·m)	SF	AGMA Class	lbs	(N)		in-lbs	(N·m)	SF	AGMA Class	lbs	(N)	Motor Power Code	Frame Size	Ratio
483	183	(20.6)	2.14	III	731	(3250)	583	151	(17.1)	2.14	III	688	(3060)	1H	6100	3
290	305	(34.4)	2.14	III	866	(3850)	350	252	(28.5)	2.14	III	814	(3620)	1H	6100	5
242	365	(41.3)	1.04	I	633	(2820)	292	303	(34.2)	1.04	I	596	(2650)	1H	6090	6
			1.38	II	633	(2820)				1.38	II	596	(2650)	1H	6095	6
			2.13	III	932	(4140)				2.13	III	876	(3900)	1H	6100	6
			2.89	III	932	(4140)				2.89	III	876	(3900)	1H	6105	6
181	487	(55.1)	1.04	I	703	(3130)	219	404	(45.6)	1.04	I	663	(2950)	1H	6090	8
			1.38	II	703	(3130)				1.38	II	663	(2950)	1H	6095	8
			2.13	III	1040	(4620)				2.13	III	978	(4350)	1H	6100	8
			2.89	III	1040	(4620)				2.89	III	978	(4350)	1H	6105	8
132	670	(75.7)	1.04	I	751	(3340)	159	555	(62.7)	1.04	I	751	(3340)	1H	6090	11
			1.38	II	751	(3340)				1.38	II	751	(3340)	1H	6095	11
			2.13	III	1180	(5250)				2.13	III	1110	(4950)	1H	6100	11
			2.89	III	1180	(5250)				2.89	III	1110	(4950)	1H	6105	11
112	792	(89.5)	1.04	I	751	(3340)	135	656	(74.1)	1.04	I	751	(3340)	1H	6090	13
			1.38	II	751	(3340)				1.38	II	751	(3340)	1H	6095	13
			2.13	III	1210	(5400)				2.13	III	1160	(5140)	1H	6100	13
			2.89	III	1210	(5400)				2.89	III	1160	(5140)	1H	6105	13
96.7	914	(103)	1.04	I	751	(3340)	117	757	(85.5)	1.04	I	751	(3340)	1H	6090	15
			1.38	II	751	(3340)				1.38	II	751	(3340)	1H	6095	15
			2.13	III	1210	(5400)				2.13	III	1210	(5400)	1H	6100	15
			2.89	III	1210	(5400)				2.89	III	1210	(5400)	1H	6105	15
85.3	1040	(117)	1.04	I	751	(3340)	103	858	(96.9)	1.04	I	751	(3340)	1H	6090	17
			1.38	II	751	(3340)				1.38	II	751	(3340)	1H	6095	17
			1.81	III	1210	(5400)				1.81	III	1210	(5400)	1H	6100	17
			2.23	III	1210	(5400)				2.23	III	1210	(5400)	1H	6105	17
69.0	1280	(145)	1.37	II	751	(3340)	83.3	1060	(120)	1.38	II	751	(3340)	1H	6095	21
			1.73	III	1210	(5400)				1.75	III	1210	(5400)	1H	6100	21
			2.08	III	1210	(5400)				2.12	III	1210	(5400)	1H	6105	21
			2.48	III	1590	(7080)				2.48	III	1500	(6670)	1H	6110	21
			2.83	III	1590	(7080)				2.83	III	1500	(6670)	1H	6115	21
58.0	1520	(172)	1.15	I	1210	(5400)	70.0	1260	(143)	1.15	I	1210	(5400)	1H	6100	25
			1.52	II	1210	(5400)				1.52	II	1210	(5400)	1H	6105	25
			1.74	III	1620	(7180)				1.74	III	1520	(6770)	1H	6110	25
			2.02	III	1620	(7180)				2.02	III	1520	(6770)	1H	6115	25
			2.81	III	1960	(8700)				2.81	III	1840	(8190)	1H	6120	25

Notes: All 1HP+ motors require EP suffix and can be used with a VFD, unless noted per column VFD [2].

[1] Selections with service factor marked with an asterisk (*) should be limited to the identified output torque.

[2] Variable Frequency Drive Availability:

AV = AF-motor (AV suffix) option available (does not apply to EP motors [1HP+])

C.F. = Consult Factory, VFD operation needs to be reviewed.

Notes: All 1HP+ motors require EP suffix and can be used with a VFD, unless noted per column VFD [2].

[1] Selections with service factor marked with an asterisk (*) should be limited to the identified output torque.

[2] Variable Frequency Drive Availability:

AV = AF-motor (AV suffix) option available (does not apply to EP motors [1HP+])

C.F. = Consult Factory, VFD operation needs to be reviewed.

Selection Tables

1.5 HP
1.1 kW

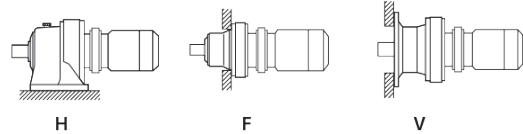

Dimension Pages:
Foot Mount (H) 2.100 - 2.129
V-Flange Mount (V) 2.130 - 2.159
F-Flange Mount (F) 2.160 - 2.189

Frequency	50 Hz	60 Hz
Input Speed	1450 RPM	1750 RPM
Number of Poles	4	

50 Hz					60 Hz					Selection							
Output Speed (RPM)	Output Torque		Service Factor ^[1]		Solid Shaft Overhung Load		Output Speed (RPM)	Output Torque		Service Factor ^[1]		Solid Shaft Overhung Load		Base			VFD ^[2]
	in-lbs	(N·m)	SF	AGMA Class	lbs	(N)		in-lbs	(N·m)	SF	AGMA Class	lbs	(N)	Motor Power Code	Frame Size	Ratio	
50.0	1770	(200)	1.10	I	1210	(5400)	60.3	1460	(165)	1.10	I	1210	(5400)	1H	6100	29	
			1.45	II	1210	(5400)				1.45	II	1210	(5400)	1H	6105	29	
			1.73	III	1650	(7350)				1.73	III	1560	(6960)	1H	6110	29	
			2.02	III	1650	(7350)				2.02	III	1560	(6960)	1H	6115	29	
			2.61	III	2030	(9050)				2.72	III	1910	(8510)	1H	6120	29	
			41.4	2130	(241)	1.09				I	1210	(5400)	50.0	1770	(200)	1.09	
1.37	II	1660	(7400)			1.37	II	1670	(7430)	1H	6110	35					
1.64	III	1660	(7400)			1.64	III	1670	(7430)	1H	6115	35					
2.16	III	2150	(9560)			2.27	III	2020	(9000)	1H	6120	35					
2.61	III	2150	(9560)			2.89	III	2020	(9000)	1H	6125	35					
33.7	2620	(296)	0.99			-	1210	(5400)	40.7	2170	(245)	0.99				-	1210
1.18			I	1710	(7610)	1.18	I	1710				(7610)	1H	6110	43		
1.38			II	1710	(7610)	1.38	II	1710				(7610)	1H	6115	43		
1.74			III	2210	(9810)	1.74	III	2150				(9580)	1H	6120	43		
2.13			III	2210	(9810)	2.16	III	2150				(9580)	1H	6125	43		
2.64			III	2690	(12000)	2.72	III	2530				(11300)	1H	6130	43		
28.4	3110	(351)	1.01	I	1710	(7600)	34.3	2570	(291)	1.01	I	1710	(7610)	1H	6115	51	
			1.48	II	2210	(9810)				1.56	II	2210	(9810)	1H	6120	51	
			1.79	III	2210	(9810)				2.07	III	2210	(9810)	1H	6125	51	
			2.22	III	2810	(12500)				2.31	III	2640	(11800)	1H	6130	51	
			2.32	III	2810	(12500)				2.66	III	2640	(11800)	1H	6135	51	
			24.6	3590	(406)	0.92				-	1700	(7570)	29.7	2980	(336)	0.92	
1.19	I	2210	(9810)			1.19	I	2210	(9810)	1H	6120	59					
1.47	II	2210	(9810)			1.47	II	2210	(9810)	1H	6125	59					
1.92	III	2950	(13100)			1.99	III	2770	(12300)	1H	6130	59					
2.22	III	2950	(13100)			2.29	III	2770	(12300)	1H	6135	59					
2.69	III	3600	(16000)			2.69	III	3600	(16000)	1H	6140	59					
2.89	III	3600	(16000)			3.32	III	3600	(16000)	1H	6145	59					
20.4	4330	(489)	1.03			I	2210	(9810)	24.6	3580	(405)	1.09				I	2210
1.60			III	3110	(13900)	1.66	III	2930				(13100)	1H	6130	71		
1.84			III	3110	(13900)	1.97	III	2930				(13100)	1H	6135	71		
2.21			III	3600	(16000)	2.21	III	3600				(16000)	1H	6140	71		
2.38			III	3600	(16000)	2.75	III	3600				(16000)	1H	6145	71		
16.7			5300	(599)	0.93	-	2160	(9620)				20.1	4390	(496)	1.03	I	2210
1.29	I	3310			(14700)	1.29	I	3160	(14100)	1H	6130				87		
1.50	II	3310			(14700)	1.74	III	3160	(14100)	1H	6135				87		
1.80	III	3600			(16000)	1.80	III	3600	(16000)	1H	6140				87		
1.96	III	3600			(16000)	2.25	III	3600	(16000)	1H	6145				87		
2.93	III	4960			(22100)	3.15	III	4960	(22100)	1H	6160				87		

Notes: All 1HP+ motors require EP suffix and can be used with a VFD, unless noted per column VFD [2].

[1] Selections with service factor marked with an asterisk (*) should be limited to the identified output torque.

[2] Variable Frequency Drive Availability:

AV = AF-motor (AV suffix) option available (does not apply to EP motors [1HP+])

C.F. = Consult Factory, VFD operation needs to be reviewed.

Selection Tables

1.5 HP
1.1 kW

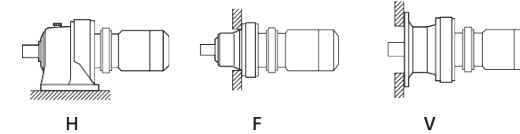

Dimension Pages:
Foot Mount (H) 2.100 - 2.129
V-Flange Mount (V) 2.130 - 2.159
F-Flange Mount (F) 2.160 - 2.189

Frequency	50 Hz	60 Hz
Input Speed	1450 RPM	1750 RPM
Number of Poles	4	

50 Hz					60 Hz					Selection														
Output Speed (RPM)	Output Torque		Service Factor ^[1]		Solid Shaft Overhung Load		Output Speed (RPM)	Output Torque		Service Factor ^[1]		Solid Shaft Overhung Load		Base			VFD ^[2]							
	in-lbs	(N·m)	SF	AGMA Class	lbs	(N)		in-lbs	(N·m)	SF	AGMA Class	lbs	(N)	Motor Power Code	Frame Size	Ratio								
13.9	4650	(525)	*	-	2210	(9810)	16.8	4650	(525)	*	-	2210	(9810)	1H	6120DB	104								
			0.93	-	2210	(9810)				1.12	I	2210	(9810)	1H	6125DB	104								
			1.15	I	3310	(14700)				1.39	II	3310	(14700)	1H	6130DC	104								
			1.39	II	3310	(14700)				1.67	III	3310	(14700)	1H	6135DC	104								
			2.59	III	4960	(22100)				3.12	III	4960	(22100)	1H	6160DC	104								
			12.0	4650	(525)	*				-	2210	(9810)	14.5	4650	(525)	*		-	2210	(9810)	1H	6120DB	121	
5510	(622)	*	-			2210	(9810)	1.44	II	3310	(14700)	1H				6125DB	121							
6980	(789)	1.19	I			3310	(14700)	2.68	III	4960	(22100)	1H				6160DC	121							
10.1	5580	(630)	*			-	2210	(9810)	12.2	5580	(630)	*				-	2210	(9810)	1H	6125DB	143			
8250			(932)			1.01	I	3310				(14700)				1.22	I	3310	(14700)	1H	6135DC		143	
1.31			II			3600	(16000)	1.38				II				3600	(16000)	1H	6140DB	143				
1.38			II	3600	(16000)	1.88	III	4960				(22100)	1H	6145DB	143									
2.25			III	4960	(22100)	2.27	III	4960				(22100)	1H	6160DC	143									
2.71			III	6630	(29500)	2.72	III	4960				(22100)	1H	6165DC	143									
8.79	5580	(630)	*	-	2210	(9810)	10.6	5580	(630)	*	-	2210	(9810)	1H	6125DB	165								
6900			(780)	*	-	3310				(14700)	1.05	I	3310	(14700)	1H	6130DC		165						
9520			(1080)	0.87	-	3310				(14700)	1.37	II	3600	(16000)	1H	6135DC		165						
1.14			I	3600	(16000)	1.38				II	3600	(16000)	1H	6140DB	165									
1.26			I	3600	(16000)	1.63				III	4960	(22100)	1H	6145DB	165									
1.63			III	4960	(22100)	1.95				III	4960	(22100)	1H	6160DC	165									
1.95			III	4960	(22100)	2.35				III	6630	(29500)	1H	6165DC	165									
2.93			III	6630	(29500)	3.53				III	6630	(29500)	1H	6175DC	165									
7.44	6900	(780)	*	-	3310	(14700)	8.97	6900	(780)	*	-	3310	(14700)	1H	6130DC	195								
			8320	(940)	*	-				3310	(14700)	1.29	I	3600	(16000)	1H		6135DC	195					
			11300	(1270)	1.07	I				3600	(16000)	1.67	III	4960	(22100)	1H		6160DC	195					
			1.38	II	4960	(22100)				1.99	III	4960	(22100)	1H	6165DC	195								
			1.65	III	4960	(22100)				2.40	III	6630	(29500)	1H	6170DC	195								
			2.48	III	6630	(29500)				2.99	III	6630	(29500)	1H	6175DC	195								

Notes: All 1HP+ motors require EP suffix and can be used with a VFD, unless noted per column VFD [2].

[1] Selections with service factor marked with an asterisk (*) should be limited to the identified output torque.

[2] Variable Frequency Drive Availability:

AV = AF-motor (AV suffix) option available (does not apply to EP motors [1HP+])

C.F. = Consult Factory, VFD operation needs to be reviewed.

Selection Tables

1.5 HP
1.1 kW

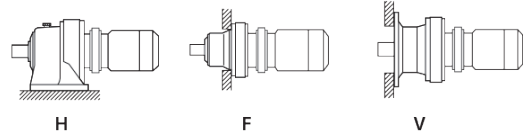

Dimension Pages:
Foot Mount (H) 2.100 - 2.129
V-Flange Mount (V) 2.130 - 2.159
F-Flange Mount (F) 2.160 - 2.189

Frequency	50 Hz	60 Hz
Input Speed	1450 RPM	1750 RPM
Number of Poles	4	

50 Hz					60 Hz					Selection			VFD ^[2]
Output Speed (RPM)	Output Torque (in-lbs)	Output Torque (N·m)	Service Factor ^[1] (SF)	Solid Shaft Overhung Load (lbs)	Output Speed (RPM)	Output Torque (in-lbs)	Output Torque (N·m)	Service Factor ^[1] (SF)	Solid Shaft Overhung Load (lbs)	Base (Motor Power Code, Frame Size, Ratio)			
6.28	8320	(940)	* -	3310 (14700)	7.58	8320	(940)	* -	3310 (14700)	1H 6135DC 231	C.F.		
	10800	(1230)	* -	3600 (16000)		11000	(1250)	0.98 -	3600 (16000)	1H 6140DB 231			
	13300	(1510)	0.89 -	3480 (15500)				1.07 I	3600 (16000)	1H 6145DB 231			
			1.17 I	4960 (22100)				1.41 II	4960 (22100)	1H 6160DC 231			
			1.39 II	4960 (22100)				1.68 III	4960 (22100)	1H 6165DC 231			
			1.68 III	6630 (29500)				2.03 III	6630 (29500)	1H 6170DC 231			
			2.09 III	6630 (29500)				2.52 III	6630 (29500)	1H 6175DC 231			
			2.69 III	9380 (41700)				3.25 III	9380 (41700)	1H 6180DB 231			
5.31	10800	(1230)	* -	3600 (16000)	6.41	10800	(1230)	* -	3600 (16000)	1H 6140DB 273	C.F.		
	11800	(1340)	* -	3600 (16000)		11800	(1340)	* -	3600 (16000)	1H 6145DB 273			
	15800	(1780)	1.18 I	4960 (22100)		13100	(1470)	1.42 II	4960 (22100)	1H 6165DC 273			
			1.42 II	6630 (29500)				1.72 III	6630 (29500)	1H 6170DC 273			
			1.77 III	6630 (29500)				2.14 III	6630 (29500)	1H 6175DC 273			
			2.28 III	9380 (41700)				2.75 III	9380 (41700)	1H 6180DB 273			
4.55	10800	(1230)	* -	3600 (16000)	5.49	10800	(1230)	* -	3600 (16000)	1H 6140DB 319	C.F.		
	12100	(1370)	* -	3540 (15800)		12100	(1370)	* -	3540 (15800)	1H 6145DB 319			
	18400	(2080)	1.01 I	4960 (22100)		15300	(1720)	1.22 I	4960 (22100)	1H 6165DC 319			
			1.22 I	6630 (29500)				1.47 II	6630 (29500)	1H 6170DC 319			
			1.51 II	6630 (29500)				1.83 III	6630 (29500)	1H 6175DC 319			
			1.95 III	9380 (41700)				2.35 III	9380 (41700)	1H 6180DB 319			
3.85	15500	(1760)	* -	4960 (22100)	4.64	15500	(1760)	* -	4960 (22100)	1H 6160DC 377	C.F.		
	18600	(2100)	* -	4960 (22100)		18000	(2040)	1.03 I	4960 (22100)	1H 6165DC 377			
	21800	(2460)	1.03 I	6630 (29500)				1.24 I	6630 (29500)	1H 6170DC 377			
			1.28 I	6630 (29500)				1.55 II	6630 (29500)	1H 6175DC 377			
			1.65 III	9380 (41700)				1.99 III	9380 (41700)	1H 6180DB 377			
			2.03 III	9380 (41700)				2.45 III	9380 (41700)	1H 6185DB 377			
3.07	18600	(2100)	* -	4960 (22100)	3.70	18600	(2100)	* -	4960 (22100)	1H 6165DC 473	C.F.		
	22400	(2530)	* -	6630 (29500)		22600	(2560)	0.99 -	6630 (29500)	1H 6170DC 473			
	27300	(3080)	1.02 I	6630 (29500)				1.23 I	6630 (29500)	1H 6175DC 473			
			1.32 II	9380 (41700)				1.59 II	9380 (41700)	1H 6180DB 473			
			1.62 III	9380 (41700)				1.96 III	9380 (41700)	1H 6185DB 473			
			2.07 III	13300 (59000)				2.50 III	13300 (59000)	1H 6190DA 473			
		2.58 III	13300 (59000)			3.11 III	13300 (59000)	1H 6195DA 473					

Notes: All 1HP+ motors require EP suffix and can be used with a VFD, unless noted per column VFD [2].
 [1] Selections with service factor marked with an asterisk (*) should be limited to the identified output torque.
 [2] Variable Frequency Drive Availability:
 AV = AF-motor (AV suffix) option available (does not apply to EP motors [1HP+])
 C.F. = Consult Factory, VFD operation needs to be reviewed.

Selection Tables

1.5 HP
1.1 kW

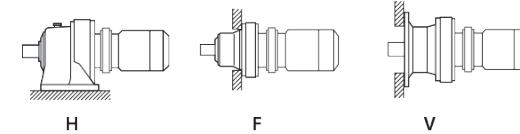

Dimension Pages:
Foot Mount (H) 2.100 - 2.129
V-Flange Mount (V) 2.130 - 2.159
F-Flange Mount (F) 2.160 - 2.189

Frequency	50 Hz	60 Hz
Input Speed	1450 RPM	1750 RPM
Number of Poles	4	

50 Hz					60 Hz					Selection			VFD ^[2]	
Output Speed (RPM)	Output Torque (in-lbs)	Output Torque (N·m)	Service Factor ^[1] (SF)	Solid Shaft Overhung Load (lbs)	Output Speed (RPM)	Output Torque (in-lbs)	Output Torque (N·m)	Service Factor ^[1] (SF)	Solid Shaft Overhung Load (lbs)	Base (Motor Power Code, Frame Size, Ratio)				
2.59	18600	(2100)	* -	4960 (22100)	3.13	18600	(2100)	* -	4960 (22100)	1H 6165DC 559	C.F.			
	22400	(2530)	* -	6630 (29500)		22400	(2530)	* -	6630 (29500)	1H 6170DC 559				
	27900	(3150)	* -	6630 (29500)		26700	(3020)	1.04 I	6630 (29500)	1H 6175DC 559				
	32300	(3640)	1.11 I	9380 (41700)				1.34 II	9380 (41700)	1H 6180DB 559				
			1.37 II	9380 (41700)				1.66 III	9380 (41700)	1H 6185DB 559				
			1.75 III	13300 (59000)				2.11 III	13300 (59000)	1H 6190DA 559				
2.23	22400	(2530)	* -	6630 (29500)	2.70	22400	(2530)	* -	6630 (29500)	1H 6170DC 649	C.F.			
	27900	(3150)	* -	6630 (29500)		27900	(3150)	* -	6630 (29500)	1H 6175DC 649				
	37500	(4230)	1.18 I	9380 (41700)		31000	(3510)	1.43 II	9380 (41700)	1H 6185DB 649				
			1.51 II	13300 (59000)				1.82 III	13300 (59000)	1H 6190DA 649				
			1.88 III	13300 (59000)				2.27 III	13300 (59000)	1H 6195DA 649				
	1.98	27900	(3150)	* -		6630 (29500)	2.39	27900	(3150)	* -		6630 (29500)	1H 6175DC 731	C.F.
42200		(4770)	1.05 I	9380 (41700)	35000	(3950)		1.27 I	9380 (41700)	1H 6185DB 731				
			1.34 II	13300 (59000)				1.62 III	13300 (59000)	1H 6190DA 731				
			1.67 III	13300 (59000)				2.02 III	13300 (59000)	1H 6195DA 731				
1.72		27900	(3150)	* -	6630 (29500)	2.08		27900	(3150)	* -	6630 (29500)	1H 6175DC 841	C.F.	
		35900	(4050)	* -	9380 (41700)			35900	(4050)	* -	9380 (41700)	1H 6180DB 841		
	44300	(5000)	* -	9380 (41700)	40200		(4540)	1.10 I	9380 (41700)	1H 6185DB 841				
	48500	(5480)	1.16 I	13300 (59000)				1.40 II	13300 (59000)	1H 6190DA 841				
			1.45 II	13300 (59000)				1.75 III	13300 (59000)	1H 6195DA 841				
	1.45	35900	(4050)	* -	9380 (41700)		1.74	35900	(4050)	* -	9380 (41700)	1H 6180DB 1003		C.F.
44300		(5000)	* -	9350 (41600)	44300	(5000)		* -	9350 (41600)	1H 6185DB 1003				
57900		(6540)	1.22 I	13200 (58500)	48000	(5420)		1.47 II	13200 (58800)	1H 6195DA 1003				
1.16		44300	(5000)	* -	9380 (41700)	1.40		44300	(5000)	* -	9380 (41700)	1H 6185DB 1247	C.F.	
		56500	(6380)	* -	13300 (59000)			56500	(6380)	* -	13300 (59000)	1H 6190DA 1247		
		72000	(8130)	0.98 -	13200 (58900)			59600	(6740)	1.18 I	13300 (59000)	1H 6195DA 1247		
	0.980	56500	(6380)	* -	13200 (58900)		1.18	56500	(6380)	* -	13200 (58900)	1H 6190DA 1479		C.F.
		70500	(7960)	* -	13100 (58400)			70700	(7990)	1.00 I	13100 (58400)	1H 6195DA 1479		
		0.784	70500	(7960)	* -			13300 (59000)	0.946	88400	(9990)	0.80 -		
0.702		70500	(7960)	* -	13100 (58100)	0.847		98700	(11200)	0.71 -	12900 (57200)	1H 6195DA 2065		

Notes: All 1HP+ motors require EP suffix and can be used with a VFD, unless noted per column VFD [2].
 [1] Selections with service factor marked with an asterisk (*) should be limited to the identified output torque.
 [2] Variable Frequency Drive Availability:
 AV = AF-motor (AV suffix) option available (does not apply to EP motors [1HP+])
 C.F. = Consult Factory, VFD operation needs to be reviewed.

Selection Tables

2 HP
1.5 kW

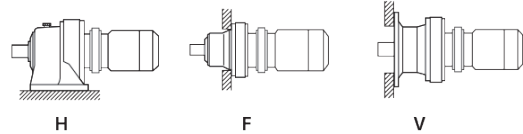

Dimension Pages:
Foot Mount (H) 2.100 - 2.129
V-Flange Mount (V) 2.130 - 2.159
F-Flange Mount (F) 2.160 - 2.189

Frequency	50 Hz	60 Hz
Input Speed	1450 RPM	1750 RPM
Number of Poles	4	

50 Hz						60 Hz						Selection					
Output Speed (RPM)	Output Torque		Service Factor ^[1]		Solid Shaft Overhung Load		Output Speed (RPM)	Output Torque		Service Factor ^[1]		Solid Shaft Overhung Load		Base			VFD ^[2]
	in-lbs	(N·m)	SF	AGMA Class	lbs	(N)		in-lbs	(N·m)	SF	AGMA Class	lbs	(N)	Motor Power Code	Frame Size	Ratio	
483	249	(28.2)	1.57	II	722	(3210)	583	206	(23.3)	1.57	II	681	(3030)	2	6100	3	
			2.12	III	722	(3210)				2.12	III	681	(3030)				
290	415	(46.9)	1.57	II	857	(3810)	350	344	(38.9)	1.57	II	807	(3590)	2	6100	5	
			2.12	III	857	(3810)				2.12	III	807	(3590)				
242	498	(56.3)	1.01	I	626	(2790)	292	413	(46.7)	1.01	I	591	(2630)	2	6095	6	
			1.56	II	928	(4130)				1.56	II	873	(3880)				
			2.12	III	928	(4130)				2.12	III	873	(3880)	2	6105	6	
			2.37	III	1050	(4670)				2.37	III	987	(4390)				
			2.61	III	1050	(4670)				2.61	III	987	(4390)				
181	665	(75.1)	1.01	I	694	(3090)	219	551	(62.2)	1.01	I	656	(2920)	2	6095	8	
			1.56	II	1030	(4600)				1.56	II	974	(4330)				
			2.12	III	1030	(4600)				2.12	III	974	(4330)	2	6105	8	
			2.37	III	1170	(5210)				2.37	III	1100	(4900)				
			2.61	III	1170	(5210)				2.61	III	1100	(4900)				
132	914	(103)	1.01	I	751	(3340)	159	757	(85.5)	1.01	I	742	(3300)	2	6095	11	
			1.56	II	1170	(5220)				1.56	II	1110	(4920)				
			2.12	III	1170	(5220)				2.12	III	1110	(4920)	2	6105	11	
			2.37	III	1340	(5950)				2.37	III	1260	(5600)				
			2.61	III	1340	(5950)				2.61	III	1260	(5600)				
112	1080	(122)	1.01	I	751	(3340)	135	895	(101)	1.01	I	741	(3300)	2	6095	13	
			1.56	II	1210	(5400)				1.56	II	1150	(5110)				
			2.12	III	1210	(5400)				2.12	III	1150	(5110)	2	6105	13	
			2.37	III	1380	(6150)				2.37	III	1300	(5790)				
			2.60	III	1380	(6150)				2.60	III	1300	(5790)				
96.7	1250	(141)	1.01	I	751	(3340)	117	1030	(117)	1.01	I	738	(3280)	2	6095	15	
			1.56	II	1210	(5400)				1.56	II	1210	(5400)				
			2.12	III	1210	(5400)				2.12	III	1210	(5400)	2	6105	15	
			2.37	III	1480	(6560)				2.37	III	1390	(6180)				
			2.60	III	1480	(6560)				2.60	III	1390	(6180)				
85.3	1410	(160)	1.01	I	751	(3340)	103	1170	(132)	1.01	I	740	(3290)	2	6095	17	
			1.32	II	1210	(5400)				1.32	II	1210	(5400)				
			1.64	III	1210	(5400)				1.64	III	1210	(5400)	2	6105	17	
			2.12	III	1490	(6620)				2.12	III	1400	(6240)				
			2.60	III	1490	(6620)				2.60	III	1400	(6240)				

Notes: All 1HP+ motors require EP suffix and can be used with a VFD, unless noted per column VFD [2].
 [1] Selections with service factor marked with an asterisk (*) should be limited to the identified output torque.
 [2] Variable Frequency Drive Availability:
 AV = AF-motor (AV suffix) option available (does not apply to EP motors [1HP+])
 C.F. = Consult Factory, VFD operation needs to be reviewed.

Selection Tables

2 HP
1.5 kW

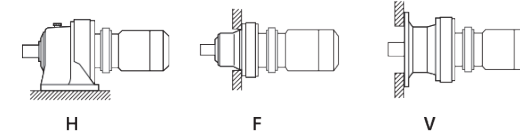

Dimension Pages:
Foot Mount (H) 2.100 - 2.129
V-Flange Mount (V) 2.130 - 2.159
F-Flange Mount (F) 2.160 - 2.189

Frequency	50 Hz	60 Hz
Input Speed	1450 RPM	1750 RPM
Number of Poles	4	

50 Hz						60 Hz						Selection											
Output Speed (RPM)	Output Torque		Service Factor ^[1]		Solid Shaft Overhung Load		Output Speed (RPM)	Output Torque		Service Factor ^[1]		Solid Shaft Overhung Load		Base			VFD ^[2]						
	in-lbs	(N·m)	SF	AGMA Class	lbs	(N)		in-lbs	(N·m)	SF	AGMA Class	lbs	(N)	Motor Power Code	Frame Size	Ratio							
69.0	1740	(197)	1.00	I	751	(3340)	83.3	1450	(163)	1.01	I	733	(3260)	2	6095	21							
			1.27	I	1210	(5400)				1.28	I	1210	(5400)										
			1.52	II	1210	(5400)				1.56	II	1210	(5400)	2	6105	21							
			1.82	III	1580	(7020)				1.82	III	1490	(6620)										
			2.07	III	1580	(7020)				2.07	III	1490	(6620)	2	6115	21							
2.64	III	1860	(8260)	2.64	III	1750	(7780)																
58.0	2080	(235)	1.12	I	1210	(5400)	70.0	1720	(194)	1.12	I	1210	(5400)	2	6105	25							
			1.28	I	1600	(7120)				1.28	I	1510	(6720)										
			1.48	II	1600	(7120)				1.48	II	1510	(6720)	2	6115	25							
			2.06	III	1950	(8650)				2.06	III	1830	(8150)										
			2.64	III	1950	(8650)				2.64	III	1830	(8150)										
50.0	2410	(272)	1.06	I	1210	(5400)	60.3	2000	(226)	1.06	I	1210	(5400)	2	6105	29							
			1.27	I	1640	(7290)				1.27	I	1550	(6900)										
			1.48	II	1640	(7290)				1.48	II	1550	(6900)	2	6115	29							
			1.91	III	2020	(8990)				1.91	III	1900	(8470)										
			2.31	III	2020	(8990)				2.31	III	1900	(8470)	2	6125	29							
2.87	III	2370	(10500)	2.87	III	2230	(9920)																
41.4	2910	(328)	0.80	-	1080	(4820)	50.0	2410	(272)	0.80	-	1200	(5330)	2	6105	35							
			1.00	I	1640	(7310)				1.00	I	1660	(7360)										
			1.21	I	1640	(7310)				1.21	I	1660	(7360)	2	6115	35							
			1.58	II	2130	(9490)				1.58	II	2010	(8940)										
			1.92	III	2130	(9490)				1.92	III	2130	(9490)	2	6125	35							
			2.37	III	2490	(11100)				2.37	III	2340	(10400)										
			2.74	III	2490	(11100)				2.74	III	2340	(10400)										
			33.7	3570	(404)	1.01				I	1700	(7540)	40.7	2960	(334)	1.01	I	1710	(7610)	2	6115	43	
						1.28				I	2210	(9810)				1.28	I	2140	(9510)				
1.56	II	2210				(9810)	1.56	II	2210	(9810)	2	6125				43							
1.93	III	2670				(11900)	1.93	III	2520	(11200)													
2.23	III	2670				(11900)	2.23	III	2520	(11200)	2	6135				43							
2.63	III	3600	(16000)	2.63	III	3580	(15900)																
28.4	4240	(479)	1.09	I	2210	(9810)	34.3	3510	(397)	1.14	I	2210	(9810)	2	6120	51							
			1.32	II	2210	(9810)				1.32	II	2210	(9810)										
			1.63	III	2790	(12400)				1.63	III	2630	(11700)	2	6130	51							
			1.70	III	2790	(12400)				1.70	III	2630	(11700)										
			2.29	III	3600	(16000)				2.29	III	3600	(16000)	2	6140	51							
			2.47	III	3600	(16000)				2.47	III	3600	(16000)										

Notes: All 1HP+ motors require EP suffix and can be used with a VFD, unless noted per column VFD [2].
 [1] Selections with service factor marked with an asterisk (*) should be limited to the identified output torque.
 [2] Variable Frequency Drive Availability:
 AV = AF-motor (AV suffix) option available (does not apply to EP motors [1HP+])
 C.F. = Consult Factory, VFD operation needs to be reviewed.

Selection Tables

2 HP
1.5 kW

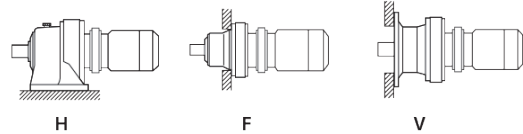

Dimension Pages:
Foot Mount (H) 2.100 - 2.129
V-Flange Mount (V) 2.130 - 2.159
F-Flange Mount (F) 2.160 - 2.189

Frequency	50 Hz	60 Hz
Input Speed	1450 RPM	1750 RPM
Number of Poles	4	

50 Hz					60 Hz					Selection									
Output Speed (RPM)	Output Torque		Service Factor ^[1]		Solid Shaft Overhung Load		Output Speed (RPM)	Output Torque		Service Factor ^[1]		Solid Shaft Overhung Load		Base			VFD ^[2]		
	in-lbs	(N·m)	SF	AGMA Class	lbs	(N)		in-lbs	(N·m)	SF	AGMA Class	lbs	(N)	Motor Power Code	Frame Size	Ratio			
24.6	4900 (554)		1.08	I	2210 (9810)	29.7	4060 (459)		1.08	I	2210 (9810)	2	6125	59					
			1.41	II	2920 (13000)				1.46	II	2750 (12200)						2	6130	59
			1.63	III	2920 (13000)				1.68	III	2750 (12200)						2	6135	59
			1.97	III	3600 (16000)				1.97	III	3600 (16000)						2	6140	59
			2.12	III	3600 (16000)				2.44	III	3600 (16000)						2	6145	59
			2.95	III	4960 (22100)				2.95	III	4960 (22100)						2	6160	59
20.4	5900 (666)		1.17	I	3090 (13700)	24.6	4890 (552)		1.22	I	2910 (12900)	2	6130	71					
			1.35	II	3090 (13700)				1.45	II	2910 (12900)						2	6135	71
			1.62	III	3600 (16000)				1.62	III	3600 (16000)						2	6140	71
			1.75	III	3600 (16000)				2.02	III	3600 (16000)						2	6145	71
			2.31	III	4960 (22100)				2.31	III	4960 (22100)						2	6160	71
16.7	7230 (817)		1.10	I	3310 (14700)	20.1	5990 (677)		1.27	I	3130 (13900)	2	6135	87					
			1.32	II	3600 (16000)				1.32	II	3600 (16000)						2	6140	87
			1.44	II	3600 (16000)				1.65	III	3600 (16000)						2	6145	87
			2.15	III	4960 (22100)				2.31	III	4960 (22100)						2	6160	87
			2.51	III	4960 (22100)				2.60	III	4960 (22100)						2	6165	87
13.9	5580 (630) 8180 (925)		*	-	2210 (9810)	16.8	5580 (630) 6780 (766)		*	-	2210 (9810)	2	6125DB	104					
			1.02	I	3310 (14700)				1.23	I	3310 (14700)						2	6135DC	104
			1.48	II	3600 (16000)				1.79	III	3600 (16000)						2	6145DC	104
			1.90	III	4960 (22100)				2.29	III	4960 (22100)						2	6160DC	104
			2.27	III	4960 (22100)				2.74	III	4960 (22100)						2	6165DC	104
			2.73	III	6630 (29500)				3.30	III	6630 (29500)						2	6170DC	104
12.0	6900 (780) 8320 (940) 9520 (1080)		*	-	3310 (14700)	14.5	6900 (780) 7890 (891)		*	-	3310 (14700)	2	6130DC	121					
			*	-	3310 (14700)				1.05	I	3310 (14700)						2	6135DC	121
			1.20	I	3600 (16000)				1.45	II	3600 (16000)						2	6145DC	121
			1.63	III	4960 (22100)				1.97	III	4960 (22100)						2	6160DC	121
			1.95	III	4960 (22100)				2.36	III	4960 (22100)						2	6165DC	121
			2.35	III	6630 (29500)				2.84	III	6630 (29500)						2	6170DC	121
			2.93	III	6630 (29500)				3.53	III	6630 (29500)						2	6175DC	121
			3.53	III	6630 (29500)				3.53	III	6630 (29500)						2	6175DC	121
10.1	6900 (780) 8320 (940) 11300 (1270)		*	-	3310 (14700)	12.2	6900 (780) 8320 (940) 9320 (1050)		*	-	3310 (14700)	2	6130DC	143					
			*	-	3310 (14700)				1.01	I	3600 (16000)						2	6145DB	143
			1.01	I	3600 (16000)				1.30	II	3600 (16000)						2	6145DC	143
			1.08	I	3600 (16000)				1.67	III	4960 (22100)						2	6160DC	143
			1.38	II	4960 (22100)				1.99	III	4960 (22100)						2	6165DC	143
			1.65	III	4960 (22100)				2.40	III	6630 (29500)						2	6170DC	143
			1.99	III	6630 (29500)				2.99	III	6630 (29500)						2	6175DC	143
			2.48	III	6630 (29500)				2.99	III	6630 (29500)						2	6175DC	143
			2.48	III	6630 (29500)				2.99	III	6630 (29500)						2	6175DC	143
			2.48	III	6630 (29500)				2.99	III	6630 (29500)						2	6175DC	143

Notes: All 1HP+ motors require EP suffix and can be used with a VFD, unless noted per column VFD [2].

[1] Selections with service factor marked with an asterisk (*) should be limited to the identified output torque.

[2] Variable Frequency Drive Availability:

AV = AF-motor (AV suffix) option available (does not apply to EP motors [1HP+])

C.F. = Consult Factory, VFD operation needs to be reviewed.

Selection Tables

2 HP
1.5 kW

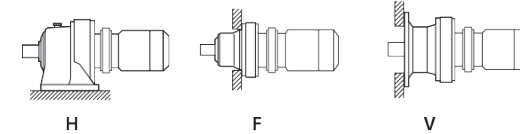

Dimension Pages:
Foot Mount (H) 2.100 - 2.129
V-Flange Mount (V) 2.130 - 2.159
F-Flange Mount (F) 2.160 - 2.189

Frequency	50 Hz	60 Hz
Input Speed	1450 RPM	1750 RPM
Number of Poles	4	

50 Hz					60 Hz					Selection									
Output Speed (RPM)	Output Torque		Service Factor ^[1]		Solid Shaft Overhung Load		Output Speed (RPM)	Output Torque		Service Factor ^[1]		Solid Shaft Overhung Load		Base			VFD ^[2]		
	in-lbs	(N·m)	SF	AGMA Class	lbs	(N)		in-lbs	(N·m)	SF	AGMA Class	lbs	(N)	Motor Power Code	Frame Size	Ratio			
8.79	8320 (940) 12000 (1360) 13000 (1470)		*	-	3310 (14700)	10.6	8320 (940) 10800 (1220)		*	-	3310 (14700)	2	6135DC	165					
			*	-	3600 (16000)				1.01	I	3600 (16000)						2	6145DB	165
			*	-	3600 (16000)				1.12	I	3600 (16000)						2	6145DC	165
			1.20	I	4960 (22100)				1.44	II	4960 (22100)						2	6160DC	165
			1.43	II	4960 (22100)				1.73	III	4960 (22100)						2	6165DC	165
			1.72	III	6630 (29500)				2.08	III	6630 (29500)						2	6170DC	165
			2.15	III	6630 (29500)				2.59	III	6630 (29500)						2	6175DC	165
			2.77	III	9380 (41700)				3.34	III	9380 (41700)						2	6180DB	165
			3.34	III	9380 (41700)				3.34	III	9380 (41700)						2	6180DB	165
			3.34	III	9380 (41700)				3.34	III	9380 (41700)						2	6180DB	165
7.44	10800 (1230) 12000 (1360) 15300 (1730)		*	-	3600 (16000)	8.97	10800 (1230) 12000 (1360) 12700 (1440)		*	-	3600 (16000)	2	6140DB	195					
			*	-	3600 (16000)				1.22	I	4960 (22100)						2	6160DC	195
			1.01	I	4960 (22100)				1.21	I	4960 (22100)						2	6165DC	195
			1.21	I	4960 (22100)				1.46	II	4960 (22100)						2	6165DC	195
			1.46	II	6630 (29500)				1.76	III	6630 (29500)						2	6170DC	195
			1.82	III	6630 (29500)				2.19	III	6630 (29500)						2	6175DC	195
6.28	11800 (1340) 18200 (2050)		*	-	3600 (16000)	7.58	11800 (1340) 15100 (1700)		*	-	3600 (16000)	2	6145DB	231					
			1.02	I	4960 (22100)				1.23	I	4960 (22100)						2	6165DC	231
			1.23	I	6630 (29500)				1.49	II	6630 (29500)						2	6170DC	231
			1.53	II	6630 (29500)				1.85	III	6630 (29500)						2	6175DC	231
			1.97	III	9380 (41700)				2.38	III	9380 (41700)						2	6180DB	231
			2.43	III	9380 (41700)				2.94	III	9380 (41700)						2	6185DB	231
5.31	15500 (1760) 18600 (2100) 21500 (2430)		*	-	4960 (22100)	6.41	15500 (1760) 17800 (2010)		*	-	4960 (22100)	2	6160DC	273					
			*	-	4960 (22100)				1.04	I	4960 (22100)						2	6165DC	273
			1.04	I	6630 (29500)				1.26	I	6630 (29500)						2	6170DC	273
			1.30	II	6630 (29500)				1.57	II	6630 (29500)						2	6175DC	273
			1.67	III	9380 (41700)				2.01	III	9380 (41700)						2	6180DB	273
			2.06	III	9380 (41700)				2.12	III	9380 (41700)						2	6185DA	273
			2.06	III	9380 (41700)				2.49	III	9380 (41700)						2	6185DB	273
			2.63	III	13300 (59000)				3.17	III	13300 (59000)						2	6190DA	273
4.55	15500 (1760) 18600 (2100) 25100 (2840)		*	-	4960 (22100)	5.49	15500 (1760) 18600 (2100) 20800 (2350)		*	-	4960 (22100)	2	6160DC	319					
			*	-	4960 (22100)				1.34	II	6630 (29500)						2	6175DC	319
			1.11	I	6630 (29500)				1.72	III	9380 (41700)						2	6180DB	319
			1.43	II	9380 (41700)				1.76	III	9380 (41700)						2	6185DA	319
			1.76	III	9380 (41700)				2.12	III	9380 (41700)						2	6185DA	319
			2.25	III	13300 (59000)				2.71	III	13300 (59000)						2	6190DA	319
2.81	III	13300 (59000)	3.39	III	13300 (59000)	2	6195DA	319											

Notes: All 1HP+ motors require EP suffix and can be used with a VFD, unless noted per column VFD [2].

[1] Selections with service factor marked with an asterisk (*) should be limited to the identified output torque.

[2] Variable Frequency Drive Availability:

AV = AF-motor (AV suffix) option available (does not apply to EP motors [1HP+])

C.F. = Consult Factory, VFD operation needs to be reviewed.

Selection Tables

2 HP
1.5 kW

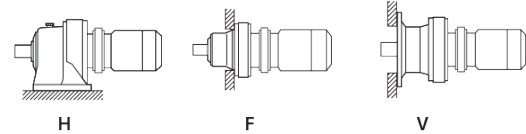

Dimension Pages:
Foot Mount (H) 2.100 - 2.129
V-Flange Mount (V) 2.130 - 2.159
F-Flange Mount (F) 2.160 - 2.189

Frequency	50 Hz	60 Hz
Input Speed	1450 RPM	1750 RPM
Number of Poles	4	

50 Hz					60 Hz					Selection			VFD ^[2]			
Output Speed (RPM)	Output Torque		Service Factor ^[1]		Solid Shaft Overhung Load		Output Speed (RPM)	Output Torque		Service Factor ^[1]		Solid Shaft Overhung Load		Base		
	in-lbs	(N·m)	SF	AGMA Class	lbs	(N)		in-lbs	(N·m)	SF	AGMA Class	lbs	(N)	Motor Power Code	Frame Size	Ratio
3.85	18600	(2100)	*	-	4960	(22100)	4.64	18600	(2100)	*	-	4960	(22100)	2	6165DC	377
	22400	(2530)	*	-	6630	(29500)		22400	(2530)	*	-	6630	(29500)	2	6170DA	377
	29700	(3350)	0.94	-	6630	(29500)		24600	(2780)	1.13	I	6630	(29500)	2	6175DC	377
			1.21	I	9380	(41700)				1.46	II	9380	(41700)	2	6180DB	377
			1.49	II	9380	(41700)				1.80	III	9380	(41700)	2	6185DA	377
			1.90	III	13300	(59000)				2.30	III	13300	(59000)	2	6190DA	377
		2.37	III	13300	(59000)			2.87	III	13300	(59000)	2	6195DA	377		
3.07	27900	(3150)	*	-	6630	(29500)	3.70	27900	(3150)	*	-	6630	(29500)	2	6175DC	473
	37200	(4210)	1.19	I	9380	(41700)		30800	(3480)	1.43	II	9380	(41700)	2	6185DA	473
			1.52	II	13300	(59000)				1.83	III	13300	(59000)	2	6190DA	473
			1.89	III	13300	(59000)				2.28	III	13300	(59000)	2	6195DA	473
2.59	27900	(3150)	*	-	6630	(29500)	3.13	27900	(3150)	*	-	6630	(29500)	2	6175DC	559
	35900	(4060)	*	-	9380	(41700)		36400	(4120)	0.99	-	9380	(41700)	2	6180DB	559
	44000	(4970)	1.01	I	9380	(41700)				1.21	I	9380	(41700)	2	6185DA	559
			1.28	I	13300	(59000)				1.55	II	13300	(59000)	2	6190DA	559
			1.60	III	13300	(59000)				1.93	III	13300	(59000)	2	6195DA	559
2.23	35900	(4050)	*	-	9380	(41700)	2.70	35900	(4050)	*	-	9380	(41700)	2	6180DB	649
	44300	(5000)	*	-	9350	(41600)		42300	(4780)	1.05	I	9370	(41700)	2	6185DA	649
	51100	(5770)	1.11	I	13200	(58700)				1.33	II	13300	(59000)	2	6190DA	649
			1.38	II	13200	(58700)				1.66	III	13300	(59000)	2	6195DA	649
1.98	35900	(4060)	*	-	9380	(41700)	2.39	35900	(4060)	*	-	9380	(41700)	2	6180DB	731
	44300	(5000)	*	-	9380	(41700)		44300	(5000)	*	-	9380	(41700)	2	6185DA	731
	57500	(6500)	1.22	I	13300	(59000)		47700	(5390)	1.48	II	13300	(59000)	2	6195DA	731
1.72	44300	(5000)	*	-	9380	(41700)	2.08	44300	(5000)	*	-	9380	(41700)	2	6185DA	841
	66200	(7480)	1.06	I	13300	(59000)		54800	(6200)	1.28	I	13300	(59000)	2	6195DA	841
1.45	56500	(6380)	*	-	13200	(58600)	1.74	56500	(6380)	*	-	13200	(58600)	2	6190DA	1003
	70500	(7960)	*	-	13100	(58100)		65400	(7390)	1.08	I	13100	(58300)	2	6195DA	1003
1.16	70500	(7960)	*	-	13300	(59000)	1.40	70500	(7960)	*	-	13300	(59000)	2	6195DA	1247
0.980	77500	(8760)	*	-	18900	(84100)	1.18	74000	(8360)	*	-	18900	(84100)	2	6205DA	1479
	99700	(11300)	*	-	23400	(104000)		96400	(10900)	1.03	I	23400	(104000)	2	6215DA	1479
0.784	82300	(9300)	*	-	18900	(84100)	0.946	82300	(9300)	*	-	18900	(84100)	2	6205DA	1849
	112000	(12700)	*	-	23400	(104000)		112000	(12700)	*	-	23400	(104000)	2	6215DA	1849
	146000	(16400)	0.97	-	32600	(145000)		121000	(13600)	1.17	I	32600	(145000)	2	6225DA	1849
0.702	82300	(9300)	*	-	18900	(84100)	0.847	82300	(9300)	*	-	18900	(84100)	2	6205DA	2065
	112000	(12700)	*	-	23400	(104000)		112000	(12700)	*	-	23400	(104000)	2	6215DA	2065
	141000	(15900)	*	-	32600	(145000)		135000	(15200)	1.04	I	32600	(145000)	2	6225DA	2065
0.572	112000	(12700)	*	-	23400	(104000)	0.690	112000	(12700)	*	-	23400	(104000)	2	6215DA	2537
	141000	(15900)	*	-	32600	(145000)		141000	(15900)	*	-	32600	(145000)	2	6225DA	2537

Notes: All 1HP+ motors require EP suffix and can be used with a VFD, unless noted per column VFD [2].

[1] Selections with service factor marked with an asterisk (*) should be limited to the identified output torque.

[2] Variable Frequency Drive Availability:

AV = AF-motor (AV suffix) option available (does not apply to EP motors [1HP+])

C.F. = Consult Factory, VFD operation needs to be reviewed.

Selection Tables

2 HP
1.5 kW

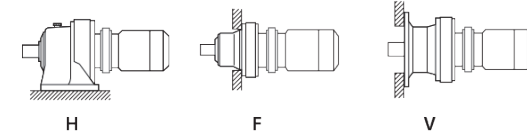

Dimension Pages:
Foot Mount (H) 2.100 - 2.129
V-Flange Mount (V) 2.130 - 2.159
F-Flange Mount (F) 2.160 - 2.189

Frequency	50 Hz	60 Hz
Input Speed	1450 RPM	1750 RPM
Number of Poles	4	

50 Hz					60 Hz					Selection			VFD ^[2]			
Output Speed (RPM)	Output Torque		Service Factor ^[1]		Solid Shaft Overhung Load		Output Speed (RPM)	Output Torque		Service Factor ^[1]		Solid Shaft Overhung Load		Base		
	in-lbs	(N·m)	SF	AGMA Class	lbs	(N)		in-lbs	(N·m)	SF	AGMA Class	lbs	(N)	Motor Power Code	Frame Size	Ratio
0.476	99700	(11300)	*	-	23400	(104000)	0.575	99700	(11300)	*	-	23400	(104000)	2	6215DA	3045
	133000	(15100)	*	-	32600	(145000)		133000	(15100)	*	-	32600	(145000)	2	6225DA	3045
0.417	112000	(12700)	*	-	23400	(104000)	0.503	112000	(12700)	*	-	23400	(104000)	2	6215DA	3481
	141000	(15900)	*	-	32600	(145000)		141000	(15900)	*	-	32600	(145000)	2	6225DA	3481
0.327	99700	(11300)	*	-	23400	(104000)	0.394	99700	(11300)	*	-	23400	(104000)	2	6215DA	4437
	133000	(15100)	*	-	32600	(145000)		133000	(15100)	*	-	32600	(145000)	2	6225DA	4437
0.282	112000	(12700)	*	-	23400	(104000)	0.341	112000	(12700)	*	-	23400	(104000)	2	6215DA	5133
	141000	(15900)	*	-	32600	(145000)		141000	(15900)	*	-	32600	(145000)	2	6225DA	5133
0.235	99700	(11300)	*	-	23400	(104000)	0.283	99700	(11300)	*	-	23400	(104000)	2	6215DA	6177
	133000	(15100)	*	-	32600	(145000)		133000	(15100)	*	-	32600	(145000)	2	6225DA	6177
0.192	99700	(11300)	*	-	23400	(104000)	0.231	99700	(11300)	*	-	23400	(104000)	2	6215DA	7569
	133000	(15100)	*	-	32600	(145000)		133000	(15100)	*	-	32600	(145000)	2	6225DA	7569

Notes: All 1HP+ motors require EP suffix and can be used with a VFD, unless noted per column VFD [2].

[1] Selections with service factor marked with an asterisk (*) should be limited to the identified output torque.

[2] Variable Frequency Drive Availability:

AV = AF-motor (AV suffix) option available (does not apply to EP motors [1HP+])

C.F. = Consult Factory, VFD operation needs to be reviewed.

Selection Tables

3 HP
2.2 kW

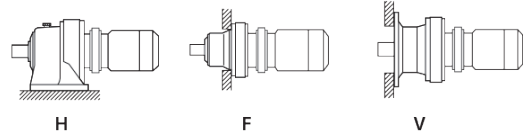

Dimension Pages:
Foot Mount (H) 2.100 - 2.129
V-Flange Mount (V) 2.130 - 2.159
F-Flange Mount (F) 2.160 - 2.189

Frequency	50 Hz	60 Hz
Input Speed	1450 RPM	1750 RPM
Number of Poles	4	

50 Hz					60 Hz					Selection							
Output Speed (RPM)	Output Torque		Service Factor ^[1]		Solid Shaft Overhung Load		Output Speed (RPM)	Output Torque		Service Factor ^[1]		Solid Shaft Overhung Load		Base			VFD ^[2]
	in-lbs	(N·m)	SF	AGMA Class	lbs	(N)		in-lbs	(N·m)	SF	AGMA Class	lbs	(N)	Motor Power Code	Frame Size	Ratio	
483	365	(41.3)	1.07	I	722	(3210)	583	303	(34.2)	1.07	I	681	(3030)	3	6100	3	
			1.45	II	722	(3210)				1.45	II	681	(3030)				
290	609	(68.8)	1.07	I	857	(3810)	350	505	(57.0)	1.07	I	807	(3590)	3	6100	5	
			1.45	II	857	(3810)				1.45	II	807	(3590)				
242	731	(82.6)	1.07	I	920	(4090)	292	606	(68.4)	1.07	I	867	(3860)	3	6100	6	
			1.45	II	920	(4090)				1.45	II	867	(3860)				
			1.61	III	1040	(4640)				1.61	III	982	(4370)				
			1.78	III	1040	(4640)				1.78	III	982	(4370)				
			2.30	III	1180	(5260)				2.30	III	1110	(4950)				
181	975	(110)	1.07	I	1020	(4560)	219	808	(91.2)	1.07	I	966	(4300)	3	6100	8	
			1.45	II	1020	(4560)				1.45	II	966	(4300)				
			1.61	III	1160	(5170)				1.61	III	1090	(4870)				
			1.78	III	1160	(5170)				1.78	III	1090	(4870)				
			2.30	III	1320	(5870)				2.30	III	1240	(5520)				
132	1340	(151)	1.07	I	1160	(5170)	159	1110	(125)	1.07	I	1100	(4870)	3	6100	11	
			1.45	II	1160	(5170)				1.45	II	1100	(4870)				
			1.61	III	1330	(5900)				1.61	III	1250	(5560)				
			1.78	III	1330	(5900)				1.78	III	1250	(5560)				
			2.30	III	1500	(6670)				2.30	III	1410	(6280)				
			2.69	III	1500	(6670)				2.69	III	1410	(6280)				
112	1580	(179)	1.07	I	1210	(5360)	135	1310	(148)	1.07	I	1140	(5060)	3	6100	13	
			1.45	II	1210	(5360)				1.45	II	1140	(5060)				
			1.61	III	1370	(6090)				1.61	III	1290	(5740)				
			1.77	III	1370	(6090)				1.77	III	1290	(5740)				
			2.30	III	1550	(6890)				2.30	III	1460	(6490)				
			2.69	III	1550	(6890)				2.69	III	1460	(6490)				
96.7	1830	(206)	1.07	I	1210	(5400)	117	1510	(171)	1.07	I	1200	(5340)	3	6100	15	
			1.45	II	1210	(5400)				1.45	II	1200	(5340)				
			1.61	III	1460	(6490)				1.61	III	1380	(6120)				
			1.77	III	1460	(6490)				1.77	III	1380	(6120)				
			2.30	III	1660	(7390)				2.30	III	1560	(6960)				
			2.69	III	1660	(7390)				2.69	III	1560	(6960)				
85.3	2070	(234)	1.12	I	1210	(5400)	103	1720	(194)	1.12	I	1210	(5400)	3	6105	17	
			1.44	II	1470	(6550)				1.44	II	1390	(6180)				
			1.77	III	1470	(6550)				1.77	III	1390	(6180)				
			2.22	III	1680	(7460)				2.30	III	1580	(7030)				
			2.57	III	1680	(7460)				2.57	III	1580	(7030)				

Selection Tables

3 HP
2.2 kW

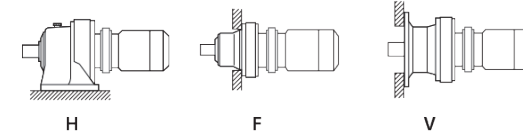

Dimension Pages:
Foot Mount (H) 2.100 - 2.129
V-Flange Mount (V) 2.130 - 2.159
F-Flange Mount (F) 2.160 - 2.189

Frequency	50 Hz	60 Hz
Input Speed	1450 RPM	1750 RPM
Number of Poles	4	

50 Hz					60 Hz					Selection							
Output Speed (RPM)	Output Torque		Service Factor ^[1]		Solid Shaft Overhung Load		Output Speed (RPM)	Output Torque		Service Factor ^[1]		Solid Shaft Overhung Load		Base			VFD ^[2]
	in-lbs	(N·m)	SF	AGMA Class	lbs	(N)		in-lbs	(N·m)	SF	AGMA Class	lbs	(N)	Motor Power Code	Frame Size	Ratio	
69.0	2560	(289)	1.04	I	1210	(5400)	83.3	2120	(240)	1.06	I	1210	(5400)	3	6105	21	
			1.24	I	1560	(6920)				1.24	I	1470	(6540)				
			1.41	II	1560	(6920)				1.41	II	1470	(6540)				
			1.80	III	1840	(8180)				1.80	III	1730	(7710)				
			2.18	III	1840	(8180)				2.22	III	1730	(7710)				
58.0	3050	(344)	1.01	I	1580	(7010)	70.0	2520	(285)	1.01	I	1490	(6620)	3	6115	25	
			1.40	II	1920	(8560)				1.40	II	1810	(8070)				
			1.80	III	1920	(8560)				1.80	III	1810	(8070)				
			2.27	III	2240	(9950)				2.35	III	2110	(9370)				
			2.62	III	2240	(9950)				2.71	III	2110	(9370)				
50.0	3530	(399)	1.01	I	1610	(7160)	60.3	2930	(331)	1.01	I	1530	(6800)	3	6115	29	
			1.30	II	2000	(8880)				1.36	II	1880	(8380)				
			1.58	II	2000	(8880)				1.71	III	1880	(8380)				
			1.95	III	2350	(10500)				2.04	III	2210	(9850)				
			2.22	III	2350	(10500)				2.56	III	2210	(9850)				
			2.71	III	3380	(15000)				2.71	III	3200	(14200)				
41.4	4260	(482)	0.82	-	1120	(4960)	50.0	3530	(399)	0.82	-	1630	(7230)	3	6115	35	
			1.08	I	2100	(9350)				1.13	I	1990	(8830)				
			1.31	II	2100	(9350)				1.45	II	1990	(8830)				
			1.62	III	2470	(11000)				1.69	III	2330	(10300)				
			1.87	III	2470	(11000)				1.93	III	2330	(10300)				
			2.37	III	3600	(16000)				2.37	III	3420	(15200)				
			2.84	III	3600	(16000)				3.42	III	3420	(15200)				
33.7	5240	(592)	1.06	I	2210	(9810)	40.7	4340	(490)	1.08	I	2110	(9380)	3	6125	43	
			1.32	II	2650	(11800)				1.36	II	2490	(11100)				
			1.52	II	2650	(11800)				1.71	III	2490	(11100)				
			1.79	III	3600	(16000)				1.79	III	3570	(15900)				
			2.12	III	3600	(16000)				2.45	III	3570	(15900)				
			2.93	III	4620	(20600)				3.39	III	4350	(19300)				
28.4	6210	(702)	0.90	-	2210	(9810)	34.3	5150	(582)	1.04	I	2190	(9760)	3	6125	51	
			1.11	I	2750	(12200)				1.16	I	2590	(11500)				
			1.16	I	2750	(12200)				1.33	II	2590	(11500)				
			1.56	II	3600	(16000)				1.56	II	3600	(16000)				
			1.68	III	3600	(16000)				1.92	III	3600	(16000)				
			2.50	III	4800	(21300)				2.62	III	4520	(20100)				
			2.99	III	4800	(21300)				3.42	III	4520	(20100)				

Notes: All 1HP+ motors require EP suffix and can be used with a VFD, unless noted per column VFD [2].

[1] Selections with service factor marked with an asterisk (*) should be limited to the identified output torque.

[2] Variable Frequency Drive Availability:

AV = AF-motor (AV suffix) option available (does not apply to EP motors [1HP+])

C.F. = Consult Factory, VFD operation needs to be reviewed.

Notes: All 1HP+ motors require EP suffix and can be used with a VFD, unless noted per column VFD [2].

[1] Selections with service factor marked with an asterisk (*) should be limited to the identified output torque.

[2] Variable Frequency Drive Availability:

AV = AF-motor (AV suffix) option available (does not apply to EP motors [1HP+])

C.F. = Consult Factory, VFD operation needs to be reviewed.

Selection Tables

3 HP
2.2 kW

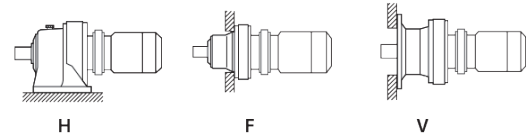

Dimension Pages:
Foot Mount (H) 2.100 - 2.129
V-Flange Mount (V) 2.130 - 2.159
F-Flange Mount (F) 2.160 - 2.189

Frequency	50 Hz	60 Hz
Input Speed	1450 RPM	1750 RPM
Number of Poles	4	

50 Hz					60 Hz					Selection							
Output Speed (RPM)	Output Torque		Service Factor ^[1]		Solid Shaft Overhung Load		Output Speed (RPM)	Output Torque		Service Factor ^[1]		Solid Shaft Overhung Load		Base			VFD ^[2]
	in-lbs	(N·m)	SF	AGMA Class	lbs	(N)		in-lbs	(N·m)	SF	AGMA Class	lbs	(N)	Motor Power Code	Frame Size	Ratio	
24.6	7190	(812)	1.11	I	2880	(12800)	29.7	5960	(673)	1.15	I	2720	(12100)	3	6135	59	
			1.35	II	3600	(16000)				1.35	II	3600	(16000)	3	6140	59	
			1.45	II	3600	(16000)				1.66	III	3600	(16000)	3	6145	59	
			2.01	III	4960	(22100)				2.01	III	4960	(22100)	3	6160	59	
			2.59	III	4960	(22100)				2.61	III	4960	(22100)	3	6165	59	
20.4	8650	(977)	0.92	-	3030	(13500)	24.6	7170	(810)	0.99	-	2870	(12800)	3	6135	71	
			1.11	I	3600	(16000)				1.11	I	3600	(16000)	3	6140	71	
			1.19	I	3600	(16000)				1.38	II	3600	(16000)	3	6145	71	
			1.58	II	4960	(22100)				1.58	II	4960	(22100)	3	6160	71	
			2.15	III	4960	(22100)				2.57	III	4960	(22100)	3	6165	71	
16.7	10600	(1200)	0.98	-	3600	(16000)	20.1	8780	(992)	1.13	I	3600	(16000)	3	6145	87	
			1.47	II	4960	(22100)				1.58	II	4960	(22100)	3	6160	87	
			1.71	III	4960	(22100)				1.77	III	4960	(22100)	3	6165	87	
13.9	6900	(780)	*	-	3310	(14700)	16.8	6900	(780)	*	-	3310	(14700)	3	6130DC	104	
			8320	(940)	*	-				3310	(14700)	8320	(940)	*	-	3310	
	12000	(1360)	1.01	I	3600	(16000)		9950	(1120)	1.22	I	3600	(16000)	3	6145DC	104	
			1.29	I	4960	(22100)				1.56	II	4960	(22100)	3	6160DC	104	
	1.55	II	4960	(22100)	1.87	III		4960	(22100)	3	6165DC	104					
	1.86	III	6630	(29500)	2.25	III		6610	(29400)	3	6170DC	104					
	2.32	III	6630	(29500)	2.80	III		6610	(29400)	3	6175DC	104					
	2.99	III	9270	(41300)	3.61	III		8720	(38800)	3	6180DB	104					
12.0	8320	(940)	*	-	3310	(14700)	14.5	8320	(940)	*	-	3310	(14700)	3	6135DC	121	
			11400	(1290)	*	-				3600	(16000)	11600	(1310)	0.99	-	3600	
	14000	(1580)	1.11	I	4960	(22100)		1.34	II	4960	(22100)	3	6160DC	121			
			1.33	II	4960	(22100)		1.61	III	4960	(22100)	3	6165DC	121			
			1.60	III	6630	(29500)		1.94	III	6630	(29500)	3	6170DC	121			
			2.00	III	6630	(29500)		2.41	III	6630	(29500)	3	6175DC	121			
2.57	III	9380	(41700)	3.11	III	9300	(41300)	3	6180DB	121							
10.1	10800	(1230)	*	-	3600	(16000)	12.2	9420	(1060)	*	-	3600	(16000)	3	6140DB	143	
			12100	(1370)	*	-				3580	(15900)	12100	(1370)	*	-	3580	
	16500	(1860)	1.13	I	4960	(22100)		13700	(1550)	1.36	II	4960	(22100)	3	6165DC	143	
			1.35	II	6630	(29500)				1.64	III	6630	(29500)	3	6170DC	143	
			1.69	III	6630	(29500)				2.04	III	6630	(29500)	3	6175DC	143	
			2.18	III	9380	(41700)				2.63	III	9380	(41700)	3	6180DB	143	
			2.63	III	9380	(41700)				3.17	III	9380	(41700)	3	6185DB	143	

Notes: All 1HP+ motors require EP suffix and can be used with a VFD, unless noted per column VFD [2].

[1] Selections with service factor marked with an asterisk (*) should be limited to the identified output torque.

[2] Variable Frequency Drive Availability:

AV = AF-motor (AV suffix) option available (does not apply to EP motors [1HP+])

C.F. = Consult Factory, VFD operation needs to be reviewed.

Selection Tables

3 HP
2.2 kW

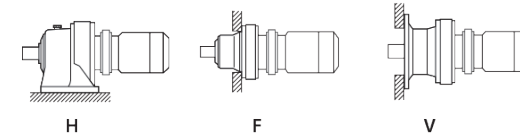

Dimension Pages:
Foot Mount (H) 2.100 - 2.129
V-Flange Mount (V) 2.130 - 2.159
F-Flange Mount (F) 2.160 - 2.189

Frequency	50 Hz	60 Hz
Input Speed	1450 RPM	1750 RPM
Number of Poles	4	

50 Hz					60 Hz					Selection									
Output Speed (RPM)	Output Torque		Service Factor ^[1]		Solid Shaft Overhung Load		Output Speed (RPM)	Output Torque		Service Factor ^[1]		Solid Shaft Overhung Load		Base			VFD ^[2]		
	in-lbs	(N·m)	SF	AGMA Class	lbs	(N)		in-lbs	(N·m)	SF	AGMA Class	lbs	(N)	Motor Power Code	Frame Size	Ratio			
8.79	10800	(1230)	*	-	3600	(16000)	10.6	10800	(1230)	*	-	3600	(16000)	3	6140DB	165			
			12000	(1360)	*	-				3600	(16000)	3	6145DC	165					
			15500	(1760)	*	-				4960	(22100)	3	6160DC	165					
			19000	(2150)	0.98	-				4960	(22100)	1.18	I	4960	(22100)	3		6165DC	165
			1.18	I	4960	(22100)				1.42	II	6630	(29500)	3	6170DC	165			
			1.46	II	6630	(29500)				1.77	III	6630	(29500)	3	6175DC	165			
			1.89	III	9380	(41700)				2.28	III	9380	(41700)	3	6180DB	165			
7.44	15500	(1760)	*	-	4960	(22100)	8.97	15500	(1760)	*	-	4960	(22100)	3	6160DC	195			
			18600	(2100)	*	-				4960	(22100)	3	6165DC	195					
			22500	(2540)	0.99	-				6630	(29500)	1.20	I	6630	(29500)	3		6170DC	195
			1.24	I	6630	(29500)				1.50	II	6630	(29500)	3	6175DC	195			
			1.60	III	9380	(41700)				1.93	III	9380	(41700)	3	6180DB	195			
			1.94	III	9380	(41700)				2.34	III	9380	(41700)	3	6185DB	195			
			2.51	III	13300	(59000)				2.69	III	13300	(59000)	3	6190DA	195			
6.28	15500	(1760)	*	-	4960	(22100)	7.58	15500	(1760)	*	-	4960	(22100)	3	6160DC	231			
			18600	(2100)	*	-				4960	(22100)	3	6165DC	231					
			26700	(3010)	1.05	I				6630	(29500)	1.26	I	6630	(29500)	3		6175DC	231
			1.34	II	9380	(41700)				1.62	III	9380	(41700)	3	6180DB	231			
			1.66	III	9380	(41700)				2.00	III	9380	(41700)	3	6185DB	231			
			2.12	III	13300	(59000)				2.56	III	13300	(59000)	3	6190DA	231			
			2.64	III	13300	(59000)				2.69	III	13300	(59000)	3	6195DA	231			
5.31	18600	(2100)	*	-	4960	(22100)	6.41	18600	(2100)	*	-	4960	(22100)	3	6165DC	273			
			22400	(2530)	*	-				6630	(29500)	3	6170DC	273					
			27900	(3150)	*	-				6630	(29500)	3	6175DC	273					
			31500	(3560)	1.14	I				9380	(41700)	1.07	I	6630	(29500)	3		6175DC	273
			1.14	I	9380	(41700)				1.37	II	9380	(41700)	3	6180DB	273			
			1.40	II	9380	(41700)				1.70	III	9380	(41700)	3	6185DB	273			
			1.79	III	13300	(59000)				2.16	III	13300	(59000)	3	6190DA	273			
4.55	22400	(2530)	*	-	6630	(29500)	5.49	22400	(2530)	*	-	6630	(29500)	3	6170DC	319			
			27900	(3150)	*	-				6630	(29500)	3	6175DC	319					
			36800	(4160)	1.20	I				9380	(41700)	1.45	II	9380	(41700)	3		6185DB	319
			1.20	I	9380	(41700)				1.85	III	13300	(59000)	3	6190DA	319			
			1.53	II	13300	(59000)				2.31	III	13300	(59000)	3	6195DA	319			
			1.91	III	13300	(59000)				2.68	III	18900	(84100)	3	6205DB	319			
			2.22	III	18900	(84100)				2.68	III	18900	(84100)	3	6205DB	319			

Notes: All 1HP+ motors require EP suffix and can be used with a VFD, unless noted per column VFD [2].

[1] Selections with service factor marked with an asterisk (*) should be limited to the identified output torque.

[2] Variable Frequency Drive Availability:

AV = AF-motor (AV suffix) option available (does not apply to EP motors [1HP+])

C.F. = Consult Factory, VFD operation needs to be reviewed.

Selection Tables

3 HP
2.2 kW

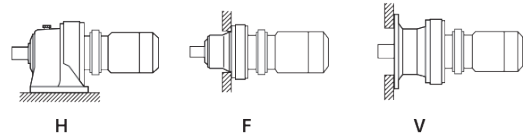

Dimension Pages:
Foot Mount (H) 2.100 - 2.129
V-Flange Mount (V) 2.130 - 2.159
F-Flange Mount (F) 2.160 - 2.189

Frequency	50 Hz	60 Hz
Input Speed	1450 RPM	1750 RPM
Number of Poles	4	

50 Hz					60 Hz					Selection							
Output Speed (RPM)	Output Torque		Service Factor ^[1]		Solid Shaft Overhung Load		Output Speed (RPM)	Output Torque		Service Factor ^[1]		Solid Shaft Overhung Load		Base			VFD ^[2]
	in-lbs	(N·m)	SF	AGMA Class	lbs	(N)		in-lbs	(N·m)	SF	AGMA Class	lbs	(N)	Motor Power Code	Frame Size	Ratio	
0.235	152000	(17200)	*	-	40100	(179000)	0.283	152000	(17200)	*	-	40100	(179000)	3	6235DA	6177	
	200000	(22600)	*	-	46800	(208000)		200000	(22600)	*	-	46800	(208000)	3	6245DA	6177	
0.192	152000	(17200)	*	-	40100	(179000)	0.231	152000	(17200)	*	-	40100	(179000)	3	6235DA	7569	
	200000	(22600)	*	-	46800	(208000)		200000	(22600)	*	-	46800	(208000)	3	6245DA	7569	

Selection Tables

5 HP
3.7 kW

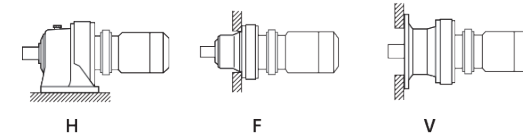

Dimension Pages:
Foot Mount (H) 2.100 - 2.129
V-Flange Mount (V) 2.130 - 2.159
F-Flange Mount (F) 2.160 - 2.189

Frequency	50 Hz	60 Hz
Input Speed	1450 RPM	1750 RPM
Number of Poles	4	

50 Hz					60 Hz					Selection							
Output Speed (RPM)	Output Torque		Service Factor ^[1]		Solid Shaft Overhung Load		Output Speed (RPM)	Output Torque		Service Factor ^[1]		Solid Shaft Overhung Load		Base			VFD ^[2]
	in-lbs	(N·m)	SF	AGMA Class	lbs	(N)		in-lbs	(N·m)	SF	AGMA Class	lbs	(N)	Motor Power Code	Frame Size	Ratio	
483	615	(69.5)	1.37	I	906	(4030)	583	509	(57.5)	1.37	I	863	(3840)	5	6120	3	
			1.68	II	906	(4030)				1.57	II	863	(3840)	5	6125	3	
			2.54	III	1050	(4690)				2.54	III	998	(4440)	5	6130	3	
290	1020	(116)	1.37	I	1070	(4780)	350	849	(95.9)	1.37	I	1020	(4550)	5	6120	5	
			1.68	II	1070	(4780)				1.57	II	1020	(4550)	5	6125	5	
			2.54	III	1250	(5560)				2.54	III	1180	(5260)	5	6130	5	
242	1230	(139)	1.06	I	1030	(4580)	292	1020	(115)	1.06	I	971	(4320)	5	6115	6	
			1.37	II	1170	(5210)				1.37	II	1100	(4910)	5	6120	6	
			1.88	III	1170	(5210)				1.57	II	1100	(4910)	5	6125	6	
			2.54	III	1380	(6120)				2.54	III	1300	(5760)	5	6130	6	
181	1640	(185)	1.06	I	1140	(5090)	219	1360	(153)	1.06	I	1080	(4800)	5	6115	8	
			1.37	II	1300	(5800)				1.37	II	1230	(5470)	5	6120	8	
			1.88	III	1300	(5800)				1.88	III	1230	(5470)	5	6125	8	
			2.54	III	1530	(6820)				2.54	III	1440	(6420)	5	6130	8	
132	2250	(255)	1.06	I	1300	(5780)	159	1870	(211)	1.06	I	1230	(5460)	5	6115	11	
			1.37	II	1480	(6580)				1.37	II	1390	(6200)	5	6120	11	
			1.60	III	1480	(6580)				1.60	III	1390	(6200)	5	6125	11	
			2.54	III	1750	(7770)				2.54	III	1650	(7320)	5	6130	11	
112	2660	(301)	1.05	I	1340	(5960)	135	2210	(249)	1.05	I	1270	(5640)	5	6115	13	
			1.37	II	1520	(6780)				1.37	II	1440	(6400)	5	6120	13	
			1.60	III	1520	(6780)				1.60	III	1440	(6400)	5	6125	13	
			2.54	III	1820	(8080)				2.54	III	1710	(7620)	5	6130	13	
			2.76	III	1820	(8080)				3.05	III	1710	(7620)	5	6135	13	
96.7	3070	(347)	1.05	I	1420	(6330)	117	2550	(288)	1.05	I	1350	(5990)	5	6115	15	
			1.37	II	1630	(7260)				1.37	II	1540	(6860)	5	6120	15	
			1.60	III	1630	(7260)				1.60	III	1540	(6860)	5	6125	15	
			2.10	III	1850	(8250)				2.10	III	1750	(7770)	5	6130	15	
			2.42	III	1850	(8250)				2.42	III	1750	(7770)	5	6135	15	
85.3	3480	(394)	1.05	I	1430	(6380)	103	2890	(326)	1.05	I	1360	(6040)	5	6115	17	
			1.32	II	1650	(7320)				1.37	II	1550	(6920)	5	6120	17	
			1.53	II	1650	(7320)				1.53	II	1550	(6920)	5	6125	17	
			1.97	III	1990	(8850)				1.97	III	1870	(8340)	5	6130	17	
			2.24	III	1990	(8850)				2.24	III	1870	(8340)	5	6135	17	
			2.72	III	2930	(13100)				2.72	III	2780	(12300)	5	6140	17	

Notes: All 1HP+ motors require EP suffix and can be used with a VFD, unless noted per column VFD [2].

[1] Selections with service factor marked with an asterisk (*) should be limited to the identified output torque.

[2] Variable Frequency Drive Availability:

AV = AF-motor (AV suffix) option available (does not apply to EP motors [1HP+])

C.F. = Consult Factory, VFD operation needs to be reviewed.

Notes: All 1HP+ motors require EP suffix and can be used with a VFD, unless noted per column VFD [2].

[1] Selections with service factor marked with an asterisk (*) should be limited to the identified output torque.

[2] Variable Frequency Drive Availability:

AV = AF-motor (AV suffix) option available (does not apply to EP motors [1HP+])

C.F. = Consult Factory, VFD operation needs to be reviewed.

Selection Tables

5 HP
3.7 kW

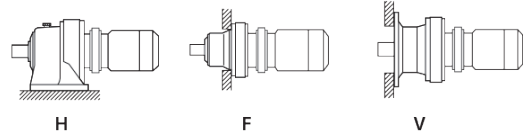

Dimension Pages:
Foot Mount (H) 2.100 - 2.129
V-Flange Mount (V) 2.130 - 2.159
F-Flange Mount (F) 2.160 - 2.189

Frequency	50 Hz	60 Hz
Input Speed	1450 RPM	1750 RPM
Number of Poles	4	

50 Hz					60 Hz					Selection							
Output Speed (RPM)	Output Torque		Service Factor ^[1]		Solid Shaft Overhung Load		Output Speed (RPM)	Output Torque		Service Factor ^[1]		Solid Shaft Overhung Load		Base			VFD ^[2]
	in-lbs	(N·m)	SF	AGMA Class	lbs	(N)		in-lbs	(N·m)	SF	AGMA Class	lbs	(N)	Motor Power Code	Frame Size	Ratio	
69.0	4300	(486)	0.84	-	1130	(5010)	83.3	3570	(403)	0.84	-	1430	(6350)	5	6115	21	
			1.07	I	1800	(8010)				1.07	I	1700	(7570)	5	6120	21	
			1.30	II	1800	(8010)				1.32	II	1700	(7570)	5	6125	21	
			1.60	III	2120	(9440)				1.66	III	2000	(8900)	5	6130	21	
			1.82	III	2120	(9440)				2.04	III	2000	(8900)	5	6135	21	
			2.34	III	3140	(14000)				2.34	III	2970	(13200)	5	6140	21	
			2.56	III	3140	(14000)				2.96	III	2970	(13200)	5	6145	21	
58.0	5120	(579)	1.07	I	1880	(8350)	70.0	4240	(480)	1.07	I	1780	(7900)	5	6125	25	
			1.35	II	2200	(9790)				1.39	II	2080	(9240)	5	6130	25	
			1.56	II	2200	(9790)				1.61	III	2080	(9240)	5	6135	25	
			1.86	III	3290	(14600)				1.86	III	3110	(13800)	5	6140	25	
			2.14	III	3290	(14600)				2.14	III	3110	(13800)	5	6145	25	
			2.67	III	3870	(17200)				2.67	III	3650	(16200)	5	6160	25	
50.0	5940	(671)	0.94	-	1940	(8640)	60.3	4920	(556)	1.02	I	1840	(8180)	5	6125	29	
			1.16	I	2310	(10300)				1.21	I	2180	(9700)	5	6130	29	
			1.32	II	2310	(10300)				1.52	II	2180	(9700)	5	6135	29	
			1.61	III	3360	(14900)				1.61	III	3180	(14200)	5	6140	29	
			2.04	III	3360	(14900)				2.04	III	3180	(14200)	5	6145	29	
			2.58	III	4040	(18000)				2.84	III	3810	(16900)	5	6160	29	
			1.11	I	2420	(10800)				1.15	I	2290	(10200)	5	6135	35	
1.41	II	3590	(16000)	1.41	II	3400	(15100)	5	6140	35							
1.69	III	3590	(16000)	2.04	III	3400	(15100)	5	6145	35							
2.17	III	4280	(19100)	2.61	III	4030	(17900)	5	6160	35							
2.59	III	4280	(19100)	3.08	III	4030	(17900)	5	6165	35							
33.7	8810	(995)	0.90	-	2580	(11500)	40.7	7300	(825)	1.02	I	2440	(10900)	5	6135	43	
			1.07	I	3600	(16000)				1.07	I	3550	(15800)	5	6140	43	
			1.26	I	3600	(16000)				1.46	II	3550	(15800)	5	6145	43	
			1.74	III	4570	(20300)				2.01	III	4310	(19200)	5	6160	43	
			2.11	III	4570	(20300)				2.14	III	4310	(19200)	5	6165	43	
			2.45	III	5170	(23000)				2.64	III	4870	(21700)	5	6170	43	
			1.00	I	3590	(16000)				1.14	I	3600	(16000)	5	6145	51	
1.49	II	4740	(21100)	1.55	II	4470	(19900)	5	6160	51							
1.78	III	4740	(21100)	2.04	III	4470	(19900)	5	6165	51							
2.07	III	5390	(24000)	2.27	III	5070	(22600)	5	6170	51							
2.67	III	5390	(24000)	3.05	III	5070	(22600)	5	6175	51							

Selection Tables

5 HP
3.7 kW

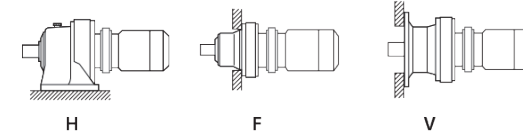

Dimension Pages:
Foot Mount (H) 2.100 - 2.129
V-Flange Mount (V) 2.130 - 2.159
F-Flange Mount (F) 2.160 - 2.189

Frequency	50 Hz	60 Hz
Input Speed	1450 RPM	1750 RPM
Number of Poles	4	

50 Hz					60 Hz					Selection							
Output Speed (RPM)	Output Torque		Service Factor ^[1]		Solid Shaft Overhung Load		Output Speed (RPM)	Output Torque		Service Factor ^[1]		Solid Shaft Overhung Load		Base			VFD ^[2]
	in-lbs	(N·m)	SF	AGMA Class	lbs	(N)		in-lbs	(N·m)	SF	AGMA Class	lbs	(N)	Motor Power Code	Frame Size	Ratio	
24.6	12100	(1370)	0.86	-	3600	(16000)	29.7	10000	(1130)	0.99	-	3600	(16000)	5	6145	59	
			1.19	I	4960	(22100)				1.19	I	4960	(22100)	5	6160	59	
			1.54	II	4960	(22100)				1.55	II	4960	(22100)	5	6165	59	
			1.79	III	5650	(25100)				1.93	III	5320	(23700)	5	6170	59	
			2.24	III	5650	(25100)				2.24	III	5320	(23700)	5	6175	59	
			2.64	III	7560	(33600)				2.64	III	7110	(31600)	5	6180	59	
			1.28	I	4960	(22100)				1.53	II	4930	(21900)	5	6165	71	
1.49	II	5970	(26500)	1.60	III	5620	(25000)	5	6170	71							
1.89	III	5970	(26500)	1.93	III	5620	(25000)	5	6175	71							
2.38	III	8040	(35700)	2.38	III	7560	(33600)	5	6180	71							
2.65	III	8040	(35700)	2.65	III	7560	(33600)	5	6185	71							
16.7	17800	(2010)	1.02	I	4910	(21800)	20.1	14800	(1670)	1.05	I	4890	(21800)	5	6165	87	
			1.23	I	6380	(28400)				1.30	II	6020	(26800)	5	6170	87	
			1.52	II	6380	(28400)				1.52	II	6020	(26800)	5	6175	87	
			1.93	III	8640	(38400)				1.93	III	8140	(36200)	5	6180	87	
			2.32	III	8640	(38400)				2.32	III	8140	(36200)	5	6185	87	
13.9	15500	(1760)	*	-	4960	(22100)	16.8	15500	(1760)	*	-	4960	(22100)	5	6160DC	104	
			18600	(2100)	*	-				4960	(22100)	5	6165DC	104			
			20200	(2280)	1.11	I				6630	(29500)	5	6170DC	104			
	1.38	II	6630	(29500)	1.34	II		6520	(29000)	5	6175DC	104					
	1.78	III	9200	(40900)	1.67	III		6520	(29000)	5	6180DB	104					
	2.15	III	9200	(40900)	2.15	III		8660	(38500)	5	6185DB	104					
	2.80	III	12900	(57200)	2.59	III		8660	(38500)	5	6190DB	104					
3.05	III	12900	(57200)	3.05	III	12100	(53800)	5	6190DB	104							
12.0	18600	(2100)	*	-	4960	(22100)	14.5	18600	(2100)	*	-	4960	(22100)	5	6165DC	121	
			23500	(2650)	1.19	I				6630	(29500)	5	6175DC	121			
	1.53	II	9380	(41700)	1.85	III		9220	(41000)	5	6180DB	121					
	1.81	III	9380	(41700)	2.19	III		9220	(41000)	5	6185DB	121					
	2.40	III	13300	(59000)	2.90	III		12900	(57300)	5	6190DB	121					
	2.86	III	13300	(59000)	3.05	III		12900	(57300)	5	6195DB	121					
10.1	22400	(2530)	*	-	6630	(29500)	12.2	23000	(2600)	0.97	-	6630	(29500)	5	6170DC	143	
			27800	(3140)	1.00	I				6630	(29500)	5	6175DC	143			
	1.29	I	9380	(41700)	1.56	II		9380	(41700)	5	6180DB	143					
	1.56	II	9380	(41700)	1.89	III		9380	(41700)	5	6185DB	143					
	2.03	III	13300	(59000)	2.46	III		13300	(59000)	5	6190DB	143					
	2.43	III	13300	(59000)	2.94	III		13300	(59000)	5	6195DB	143					

Notes: All 1HP+ motors require EP suffix and can be used with a VFD, unless noted per column VFD [2].

[1] Selections with service factor marked with an asterisk (*) should be limited to the identified output torque.

[2] Variable Frequency Drive Availability:

AV = AF-motor (AV suffix) option available (does not apply to EP motors [1HP+])

C.F. = Consult Factory, VFD operation needs to be reviewed.

Notes: All 1HP+ motors require EP suffix and can be used with a VFD, unless noted per column VFD [2].

[1] Selections with service factor marked with an asterisk (*) should be limited to the identified output torque.

[2] Variable Frequency Drive Availability:

AV = AF-motor (AV suffix) option available (does not apply to EP motors [1HP+])

C.F. = Consult Factory, VFD operation needs to be reviewed.

Selection Tables

**5 HP
3.7 kW**

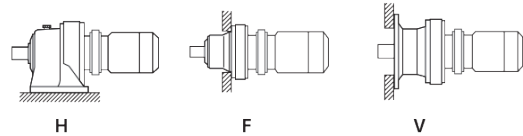

Dimension Pages:
Foot Mount (H) 2.100 - 2.129
V-Flange Mount (V) 2.130 - 2.159
F-Flange Mount (F) 2.160 - 2.189

Frequency	50 Hz	60 Hz
Input Speed	1450 RPM	1750 RPM
Number of Poles	4	

50 Hz					60 Hz					Selection							
Output Speed (RPM)	Output Torque		Service Factor ^[1]		Solid Shaft Overhung Load		Output Speed (RPM)	Output Torque		Service Factor ^[1]		Solid Shaft Overhung Load		Base			VFD ^[2]
	in-lbs	(N·m)	SF	AGMA Class	lbs	(N)		in-lbs	(N·m)	SF	AGMA Class	lbs	(N)	Motor Power Code	Frame Size	Ratio	
8.79	22400	(2530)	*	-	6630	(29500)	10.6	22400	(2530)	*	-	6630	(29500)	5	6170DC	165	
	27900	(3150)	*	-	6630	(29500)		26500	(3000)	1.05	I	6630	(29500)	5	6175DC	165	
	32000	(3620)	1.12	I	9380	(41700)		1.35	II	9380	(41700)	5	6180DB	165			
			1.36	II	9380	(41700)		1.64	III	9380	(41700)	5	6185DB	165			
			1.76	III	13300	(59000)		2.13	III	13300	(59000)	5	6190DB	165			
	2.19	III	13300	(59000)	2.64	III		13300	(59000)	5	6195DB	165					
	2.56	III	18900	(84100)	3.05	III		18900	(84100)	5	6205DB	165					
7.44	27900	(3150)	*	-	6630	(29500)	8.97	27900	(3150)	*	-	6630	(29500)	5	6175DC	195	
	37900	(4280)	1.15	I	9380	(41700)		1.39	II	9380	(41700)	5	6185DB	195			
			1.49	II	13300	(59000)		1.60	III	13300	(59000)	5	6190DA	195			
			1.49	II	13300	(59000)		1.80	III	13300	(59000)	5	6190DB	195			
	1.85	III	13300	(59000)	2.23	III		13300	(59000)	5	6195DB	195					
	2.17	III	18900	(84100)	2.62	III		18900	(84100)	5	6205DB	195					
	2.76	III	23400	(104000)	3.05	III		23400	(104000)	5	6215DA	195					
2.85	III	23400	(104000)	3.43	III	23400	(104000)	5	6215DB	195	C.F.						
6.28	35900	(4050)	*	-	9380	(41700)	7.58	37200	(4200)	0.97	-	9380	(41700)	5	6180DB	231	
	44800	(5070)	0.99	-	9380	(41700)		1.19	I	9380	(41700)	5	6185DB	231			
			1.26	I	13300	(59000)		1.52	II	13300	(59000)	5	6190DA	231			
	1.57	II	13300	(59000)	1.60	III		13300	(59000)	5	6195DA	231					
	1.57	II	13300	(59000)	1.90	III		13300	(59000)	5	6195DB	231					
	1.83	III	18900	(84100)	2.21	III		18900	(84100)	5	6205DB	231					
	2.47	III	23400	(104000)	2.98	III		23400	(104000)	5	6215DA	231					
	2.92	III	31400	(140000)	3.05	III		29700	(132000)	5	6225DA	231					
	2.92	III	31400	(140000)	3.53	III		29700	(132000)	5	6225DB	231	C.F.				
5.31	35900	(4050)	*	-	9380	(41700)	6.41	35900	(4050)	*	-	9380	(41700)	5	6180DB	273	
	44300	(5000)	*	-	9380	(41700)		43900	(4960)	1.01	I	9380	(41700)	5	6185DB	273	
			1.07	I	13300	(59000)		1.29	I	13300	(59000)	5	6190DA	273			
	1.33	II	13300	(59000)	1.60	III		13300	(59000)	5	6195DA	273					
	1.55	II	18900	(84100)	1.87	III		18900	(84100)	5	6205DB	273					
	2.09	III	23400	(104000)	2.52	III		23400	(104000)	5	6215DA	273					
	2.47	III	32600	(145000)	2.98	III		31200	(139000)	5	6225DA	273					
4.55	44300	(5000)	*	-	9380	(41700)	5.49	44300	(5000)	*	-	9380	(41700)	5	6185DB	319	
	61900	(7000)	1.14	I	13300	(59000)		51300	(5800)	1.37	II	13300	(59000)	5	6195DA	319	
			1.32	II	18900	(84100)		1.59	II	18900	(84100)	5	6205DB	319			
	1.81	III	23400	(104000)	2.18	III		23400	(104000)	5	6215DA	319					
	2.15	III	32600	(145000)	2.59	III		32400	(144000)	5	6225DA	319					
	2.70	III	40100	(179000)	3.26	III		40100	(179000)	5	6235DA	319	C.F.				

Selection Tables

**5 HP
3.7 kW**

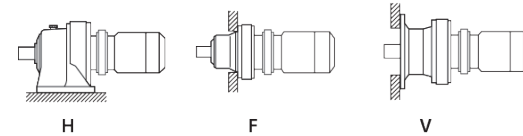

Dimension Pages:
Foot Mount (H) 2.100 - 2.129
V-Flange Mount (V) 2.130 - 2.159
F-Flange Mount (F) 2.160 - 2.189

Frequency	50 Hz	60 Hz
Input Speed	1450 RPM	1750 RPM
Number of Poles	4	

50 Hz					60 Hz					Selection							
Output Speed (RPM)	Output Torque		Service Factor ^[1]		Solid Shaft Overhung Load		Output Speed (RPM)	Output Torque		Service Factor ^[1]		Solid Shaft Overhung Load		Base			VFD ^[2]
	in-lbs	(N·m)	SF	AGMA Class	lbs	(N)		in-lbs	(N·m)	SF	AGMA Class	lbs	(N)	Motor Power Code	Frame Size	Ratio	
3.85	56500	(6380)	*	-	13300	(59000)	4.64	56500	(6380)	*	-	13300	(59000)	5	6190DA	377	
	73200	(8270)	0.96	-	13200	(58900)		60600	(6850)	1.16	I	13300	(59000)	5	6195DA	377	
			1.03	I	18900	(84100)		1.17	I	18900	(84100)	5	6205DA	377			
			1.12	I	18900	(84100)		1.35	II	18900	(84100)	5	6205DB	377			
	1.53	II	23400	(104000)	1.85	III		23400	(104000)	5	6215DA	377					
	1.82	III	32600	(145000)	2.20	III		32600	(145000)	5	6225DA	377					
	2.29	III	40100	(179000)	2.76	III		40100	(179000)	5	6235DA	377	C.F.				
3.07	70500	(7960)	*	-	13300	(59000)	3.70	70500	(7960)	*	-	13300	(59000)	5	6195DA	473	
	82300	(9300)	*	-	18900	(84100)		76100	(8600)	1.08	I	18900	(84100)	5	6205DB	473	
			1.22	I	23400	(104000)		1.47	II	23400	(104000)	5	6215DA	473			
	91800	(10400)	1.54	II	32600	(145000)		1.86	III	32600	(145000)	5	6225DA	473			
			1.98	III	40100	(179000)		2.38	III	40100	(179000)	5	6235DA	473	C.F.		
2.49	III	46800	(208000)	3.00	III	46800	(208000)	5	6245DA	473	C.F.						
2.59	109000	(12300)	1.03	I	23400	(104000)	3.13	89900	(10200)	1.25	I	23400	(104000)	5	6215DA	559	
			1.31	II	32600	(145000)		1.58	II	32600	(145000)	5	6225DA	559			
			1.67	III	40100	(179000)		2.02	III	40100	(179000)	5	6235DA	559	C.F.		
			2.10	III	46800	(208000)		2.54	III	46800	(208000)	5	6245DA	559	C.F.		
2.81	III	58000	(258000)	3.40	III	58000	(258000)	5	6255DA	559	C.F.						
2.23	112000	(12700)	*	-	23400	(104000)	2.70	104000	(11800)	1.07	I	23400	(104000)	5	6215DA	649	
	126000	(14200)	1.12	I	32600	(145000)		1.35	II	32600	(145000)	5	6225DA	649			
			1.44	II	40100	(179000)		1.74	III	40100	(179000)	5	6235DA	649	C.F.		
	1.81	III	46800	(208000)	2.19	III		46800	(208000)	5	6245DA	649	C.F.				
	2.42	III	58000	(258000)	2.93	III		58000	(258000)	5	6255DA	649	C.F.				
1.98	112000	(12700)	*	-	23400	(104000)	2.39	112000	(12700)	*	-	23400	(104000)	5	6215DA	731	
	142000	(16000)	1.00	I	32600	(145000)		118000	(13300)	1.20	I	32600	(145000)	5	6225DA	731	
			1.28	I	40100	(179000)		1.54	II	40100	(179000)	5	6235DA	731			
	1.61	III	46800	(208000)	1.94	III		46800	(208000)	5	6245DA	731					
	2.15	III	58000	(258000)	2.60	III		58000	(258000)	5	6255DA	731	C.F.				
1.72	112000	(12700)	*	-	23400	(104000)	2.08	112000	(12700)	*	-	23400	(104000)	5	6215DA	841	
	133000	(15000)	*	-	32600	(145000)		135000	(15300)	0.98	-	32600	(145000)	5	6225DA	841	
			1.02	I	40100	(179000)		1.24	I	40100	(179000)	5	6235DA	841			
	163000	(18400)	1.40	II	46800	(208000)		1.69	III	46800	(208000)	5	6245DA	841			
1.76	III	58000	(258000)	2.13	III	58000	(258000)	5	6255DA	841	C.F.						
1.45	141000	(15900)	*	-	32600	(145000)	1.74	141000	(15900)	*	-	32600	(145000)	5	6225DA	1003	
	181000	(20500)	*	-	40100	(179000)		161000	(18200)	1.12	I	40100	(179000)	5	6235DA	1003	
			1.17	I	46800	(208000)		1.42	II	46800	(208000)	5	6245DA	1003			
	195000	(22000)	1.57	II	58000	(258000)		1.89	III	58000	(258000)	5	6255DA	1003	C.F.		

Notes: All 1HP+ motors require EP suffix and can be used with a VFD, unless noted per column VFD [2].

[1] Selections with service factor marked with an asterisk (*) should be limited to the identified output torque.

[2] Variable Frequency Drive Availability:

AV = AF-motor (AV suffix) option available (does not apply to EP motors [1HP+])

C.F. = Consult Factory, VFD operation needs to be reviewed.

Notes: All 1HP+ motors require EP suffix and can be used with a VFD, unless noted per column VFD [2].

[1] Selections with service factor marked with an asterisk (*) should be limited to the identified output torque.

[2] Variable Frequency Drive Availability:

AV = AF-motor (AV suffix) option available (does not apply to EP motors [1HP+])

C.F. = Consult Factory, VFD operation needs to be reviewed.

Selection Tables

5 HP
3.7 kW

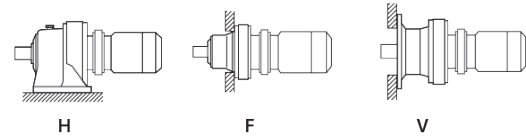

Dimension Pages:
Foot Mount (H) 2.100 - 2.129
V-Flange Mount (V) 2.130 - 2.159
F-Flange Mount (F) 2.160 - 2.189

Frequency	50 Hz	60 Hz
Input Speed	1450 RPM	1750 RPM
Number of Poles	4	

50 Hz					60 Hz					Selection			VFD ^[2]				
Output Speed (RPM)	Output Torque		Service Factor ^[1]		Solid Shaft Overhung Load		Output Speed (RPM)	Output Torque		Service Factor ^[1]		Solid Shaft Overhung Load		Base			
	in-lbs	(N·m)	SF	AGMA Class	lbs	(N)		in-lbs	(N·m)	SF	AGMA Class	lbs	(N)	Motor Power Code	Frame Size	Ratio	
1.16	181000	(20500)	*	-	40100	(179000)	1.40	181000	(20500)	*	-	40100	(179000)	5	6235DA	1247	C.F.
	228000	(25800)	*	-	46800	(208000)		201000	(22700)	1.14	I	46800	(208000)	5	6245DA	1247	
	242000	(27300)	1.26	I	58000	(258000)		58000	(258000)	1.52	II	58000	(258000)	5	6255DA	1247	
0.980	200000	(22600)	*	-	46800	(208000)	1.18	200000	(22600)	*	-	46800	(208000)	5	6245DA	1479	C.F.
	287000	(32400)	0.96	-	58000	(258000)		238000	(26900)	1.15	I	58000	(258000)	5	6255DA	1479	
0.784	305000	(34500)	*	-	58000	(258000)	0.946	297000	(33600)	1.03	I	58000	(258000)	5	6255DA	1849	
0.702	305000	(34500)	*	-	58000	(258000)	0.847	305000	(34500)	*	-	58000	(258000)	5	6255DA	2065	C.F.
0.572	305000	(34500)	*	-	58000	(258000)	0.690	305000	(34500)	*	-	58000	(258000)	5	6255DA	2537	
0.476	274000	(31000)	*	-	58000	(258000)	0.575	274000	(31000)	*	-	58000	(258000)	5	6255DA	3045	C.F.
0.417	305000	(34500)	*	-	58000	(258000)	0.503	305000	(34500)	*	-	58000	(258000)	5	6255DA	3481	
0.327	274000	(31000)	*	-	58000	(258000)	0.394	274000	(31000)	*	-	58000	(258000)	5	6255DA	4437	
0.282	305000	(34500)	*	-	58000	(258000)	0.341	305000	(34500)	*	-	58000	(258000)	5	6255DA	5133	
0.235	274000	(31000)	*	-	58000	(258000)	0.283	274000	(31000)	*	-	58000	(258000)	5	6255DA	6177	
0.192	274000	(31000)	*	-	58000	(258000)	0.231	274000	(31000)	*	-	58000	(258000)	5	6255DA	7569	

Selection Tables

7.5 HP
5.5 kW

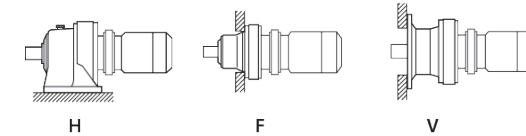

Dimension Pages:
Foot Mount (H) 2.100 - 2.129
V-Flange Mount (V) 2.130 - 2.159
F-Flange Mount (F) 2.160 - 2.189

Frequency	50 Hz	60 Hz
Input Speed	1450 RPM	1750 RPM
Number of Poles	4	

50 Hz					60 Hz					Selection			VFD ^[2]			
Output Speed (RPM)	Output Torque		Service Factor ^[1]		Solid Shaft Overhung Load		Output Speed (RPM)	Output Torque		Service Factor ^[1]		Solid Shaft Overhung Load		Base		
	in-lbs	(N·m)	SF	AGMA Class	lbs	(N)		in-lbs	(N·m)	SF	AGMA Class	lbs	(N)	Motor Power Code	Frame Size	Ratio
483	914	(103)	1.13	I	906	(4030)	583	757	(85.5)	1.06	I	863	(3840)	8	6125	3
			1.71	II	1040	(4630)				1.71	II	985	(4380)	8	6130	3
			2.05	III	1040	(4630)				2.05	III	985	(4380)	8	6135	3
290	1520	(172)	1.13	I	1070	(4780)	350	1260	(143)	1.06	I	1020	(4550)	8	6125	5
			1.71	II	1230	(5490)				1.71	II	1170	(5190)	8	6130	5
			2.05	III	1230	(5490)				2.05	III	1170	(5190)	8	6135	5
242	1830	(206)	1.27	I	1160	(5140)	292	1510	(171)	1.06	I	1090	(4850)	8	6125	6
			1.71	III	1360	(6060)				1.71	III	1280	(5710)	8	6130	6
			2.05	III	1360	(6060)				2.05	III	1280	(5710)	8	6135	6
			2.37	III	2110	(9370)				2.37	III	1990	(8860)	8	6140	6
			2.75	III	2110	(9370)				2.75	III	1990	(8860)	8	6145	6
181	2440	(275)	1.26	I	1280	(5710)	219	2020	(228)	1.26	I	1210	(5400)	8	6125	8
			1.71	III	1520	(6740)				1.71	III	1430	(6360)	8	6130	8
			2.05	III	1520	(6740)				2.05	III	1430	(6360)	8	6135	8
			2.37	III	2330	(10400)				2.37	III	2210	(9820)	8	6140	8
			2.75	III	2330	(10400)				2.75	III	2210	(9820)	8	6145	8
132	3350	(379)	1.08	I	1450	(6450)	159	2780	(314)	1.08	I	1370	(6100)	8	6125	11
			1.71	III	1730	(7680)				1.71	III	1630	(7240)	8	6130	11
			2.05	III	1730	(7680)				2.05	III	1630	(7240)	8	6135	11
			2.37	III	2620	(11600)				2.37	III	2480	(11000)	8	6140	11
			2.75	III	2620	(11600)				2.75	III	2480	(11000)	8	6145	11
112	3960	(447)	1.08	I	1490	(6630)	135	3280	(371)	1.08	I	1410	(6280)	8	6125	13
			1.71	III	1790	(7980)				1.71	III	1690	(7530)	8	6130	13
			1.86	III	1790	(7980)				2.05	III	1690	(7530)	8	6135	13
			2.37	III	2680	(11900)				2.37	III	2530	(11300)	8	6140	13
			2.74	III	2680	(11900)				2.74	III	2530	(11300)	8	6145	13
96.7	4570	(516)	1.08	I	1600	(7100)	117	3790	(428)	1.08	I	1510	(6730)	8	6125	15
			1.42	II	1830	(8130)				1.42	II	1730	(7680)	8	6130	15
			1.63	III	1830	(8130)				1.63	III	1730	(7680)	8	6135	15
			2.18	III	2800	(12400)				2.18	III	2650	(11800)	8	6140	15
			2.63	III	2800	(12400)				2.74	III	2650	(11800)	8	6145	15
85.3	5180	(585)	1.03	I	1610	(7150)	103	4290	(485)	1.03	I	1520	(6780)	8	6125	17
			1.32	II	1960	(8710)				1.32	II	1850	(8230)	8	6130	17
			1.51	II	1960	(8710)				1.51	II	1850	(8230)	8	6135	17
			1.83	III	2920	(13000)				1.83	III	2760	(12300)	8	6140	17
			2.18	III	2920	(13000)				2.18	III	2760	(12300)	8	6145	17
			2.37	III	3430	(15300)				2.37	III	3230	(14400)	8	6160	17

Notes: All 1HP+ motors require EP suffix and can be used with a VFD, unless noted per column VFD [2].

[1] Selections with service factor marked with an asterisk (*) should be limited to the identified output torque.

[2] Variable Frequency Drive Availability:

AV = AF-motor (AV suffix) option available (does not apply to EP motors [1HP+])

C.F. = Consult Factory, VFD operation needs to be reviewed.

Notes: All 1HP+ motors require EP suffix and can be used with a VFD, unless noted per column VFD [2].

[1] Selections with service factor marked with an asterisk (*) should be limited to the identified output torque.

[2] Variable Frequency Drive Availability:

AV = AF-motor (AV suffix) option available (does not apply to EP motors [1HP+])

C.F. = Consult Factory, VFD operation needs to be reviewed.

Selection Tables

7.5 HP
5.5 kW

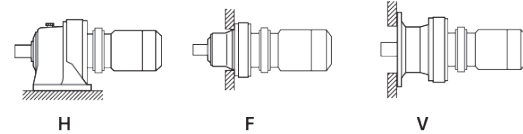

Dimension Pages:
Foot Mount (H) 2.100 - 2.129
V-Flange Mount (V) 2.130 - 2.159
F-Flange Mount (F) 2.160 - 2.189

Frequency	50 Hz	60 Hz
Input Speed	1450 RPM	1750 RPM
Number of Poles	4	

50 Hz						60 Hz						Selection					
Output Speed (RPM)	Output Torque		Service Factor ^[1]		Solid Shaft Overhung Load		Output Speed (RPM)	Output Torque		Service Factor ^[1]		Solid Shaft Overhung Load		Base			VFD ^[2]
	in-lbs	(N·m)	SF	AGMA Class	lbs	(N)		in-lbs	(N·m)	SF	AGMA Class	lbs	(N)	Motor Power Code	Frame Size	Ratio	
69.0	6400	(723)	0.87	-	1750	(7780)	83.3	5300	(599)	0.89	-	1660	(7390)	8	6125	21	
			1.08	I	2080	(9260)				1.12	I	1970	(8760)	8	6130	21	
			1.22	I	2080	(9260)				1.37	II	1970	(8760)	8	6135	21	
			1.58	II	3120	(13900)				1.58	II	2960	(13100)	8	6140	21	
			1.72	III	3120	(13900)				1.99	III	2960	(13100)	8	6145	21	
			2.35	III	3680	(16400)				2.35	III	3460	(15400)	8	6160	21	
			2.91	III	3680	(16400)				2.92	III	3460	(15400)	8	6165	21	
58.0	7610	(860)	1.05	I	2150	(9580)	70.0	6310	(713)	1.08	I	2040	(9070)	8	6135	25	
			1.25	I	3270	(14500)				1.25	I	3090	(13800)	8	6140	25	
			1.44	II	3270	(14500)				1.44	II	3090	(13800)	8	6145	25	
			1.79	III	3840	(17100)				1.79	III	3620	(16100)	8	6160	25	
			2.44	III	3840	(17100)				2.74	III	3620	(16100)	8	6165	25	
			2.83	III	4320	(19200)				2.87	III	4060	(18100)	8	6170	25	
			50.0	8830	(998)	0.89				-	2250	(10000)	60.3	7320	(827)	1.03	
1.08	I	3340				(14800)	1.08	I	3160	(14100)	8	6140				29	
1.37	II	3340				(14800)	1.37	II	3160	(14100)	8	6145				29	
1.74	III	4000				(17800)	1.91	III	3770	(16800)	8	6160				29	
2.08	III	4000				(17800)	2.08	III	3770	(16800)	8	6165				29	
2.45	III	4550				(20200)	2.60	III	4290	(19100)	8	6170				29	
41.4	10700	(1200)				1.14	I	3560	(15900)	50.0	8830	(998)				1.37	II
			1.46	II	4230	(18800)	1.76	III	3990				(17800)	8	6160	35	
			1.74	III	4230	(18800)	2.08	III	3990				(17800)	8	6165	35	
			2.03	III	4820	(21400)	2.18	III	4540				(20200)	8	6170	35	
			2.62	III	4820	(21400)	2.74	III	4540				(20200)	8	6175	35	
			33.7	13100	(1480)	0.85	-	3400	(15100)				40.7	10900	(1230)	0.98	-
1.17	I	4510				(20000)	1.35	II	4250	(18900)	8	6160				43	
1.42	II	4510				(20000)	1.44	II	4250	(18900)	8	6165				43	
1.65	III	5120				(22800)	1.77	III	4830	(21500)	8	6170				43	
2.05	III	5120				(22800)	2.05	III	4830	(21500)	8	6175				43	
2.74	III	6940				(30900)	2.74	III	6540	(29100)	8	6180				43	
28.4	15500	(1760)	1.00	I	4670	(20800)	34.3	12900	(1450)	1.05	I	4410	(19600)	8	6160	51	C.F.
			1.20	I	4670	(20800)				1.37	II	4410	(19600)	8	6165	51	
			1.39	II	5330	(23700)				1.53	II	5030	(22400)	8	6170	51	
			1.79	III	5330	(23700)				2.05	III	5030	(22400)	8	6175	51	
			2.18	III	7180	(31900)				2.18	III	6760	(30100)	8	6180	51	
			2.74	III	7180	(31900)				2.74	III	6760	(30100)	8	6185	51	

Notes: All 1HP+ motors require EP suffix and can be used with a VFD, unless noted per column VFD [2].

[1] Selections with service factor marked with an asterisk (*) should be limited to the identified output torque.

[2] Variable Frequency Drive Availability:

AV = AF-motor (AV suffix) option available (does not apply to EP motors [1HP+])

C.F. = Consult Factory, VFD operation needs to be reviewed.

Selection Tables

7.5 HP
5.5 kW

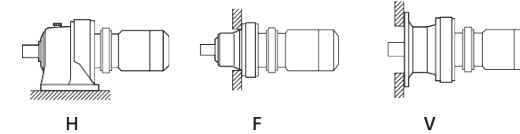

Dimension Pages:
Foot Mount (H) 2.100 - 2.129
V-Flange Mount (V) 2.130 - 2.159
F-Flange Mount (F) 2.160 - 2.189

Frequency	50 Hz	60 Hz
Input Speed	1450 RPM	1750 RPM
Number of Poles	4	

50 Hz						60 Hz						Selection					
Output Speed (RPM)	Output Torque		Service Factor ^[1]		Solid Shaft Overhung Load		Output Speed (RPM)	Output Torque		Service Factor ^[1]		Solid Shaft Overhung Load		Base			VFD ^[2]
	in-lbs	(N·m)	SF	AGMA Class	lbs	(N)		in-lbs	(N·m)	SF	AGMA Class	lbs	(N)	Motor Power Code	Frame Size	Ratio	
24.6	18000	(2030)	1.03	I	4960	(22100)	29.7	14900	(1680)	1.05	I	4890	(21700)	8	6165	59	
			1.20	I	5580	(24800)				1.30	II	5260	(23400)	8	6170	59	
			1.51	II	5580	(24800)				1.51	II	5260	(23400)	8	6175	59	
			1.77	III	7510	(33400)				1.77	III	7070	(31400)	8	6180	59	
			2.18	III	7510	(33400)				2.18	III	7070	(31400)	8	6185	59	
			2.78	III	10600	(47000)				2.78	III	9930	(44200)	8	6190	59	
			20.4	21600	(2440)	0.86				-	4960	(22100)	24.6	17900	(2020)	1.03	
1.00	I	5880				(26200)	1.08	I	5550	(24700)	8	6170				71	
1.27	I	5880				(26200)	1.30	II	5550	(24700)	8	6175				71	
1.60	III	7970				(35500)	1.60	III	7510	(33400)	8	6180				71	
1.78	III	7970				(35500)	1.78	III	7510	(33400)	8	6185				71	
2.46	III	11200				(49800)	2.46	III	10500	(46900)	8	6190				71	
2.84	III	11200				(49800)	2.84	III	10500	(46900)	8	6195				71	
16.7	26500	(2990)	1.02	I	6270	(27900)	20.1	22000	(2480)	1.02	I	5930	(26400)	8	6175	87	
			1.30	II	8560	(38100)				1.30	II	8070	(35900)	8	6180	87	
			1.56	II	8560	(38100)				1.56	II	8070	(35900)	8	6185	87	
			2.13	III	12100	(53600)				2.15	III	11300	(50500)	8	6190	87	
			2.48	III	12100	(53600)				2.48	III	11300	(50500)	8	6195	87	
			13.9	18600	(2100)	*				-	4960	(22100)	16.8	18600	(2100)	*	
*	-	6630				(29500)	*	-	6440	(28600)	8	6170DC				104	
*	-	6630				(29500)	1.12	I	6400	(28500)	8	6175DC				104	
1.20	I	9100				(40500)	1.45	II	8580	(38200)	8	6180DB				104	
1.45	II	9100				(40500)	1.74	III	8580	(38200)	8	6185DB				104	
1.88	III	12800				(56800)	2.05	III	12000	(53500)	8	6190DB				104	
12.0	22400	(2530)	*	-	6630	(29500)	14.5	22400	(2530)	*	-	6630	(29500)	8	6170DC	121	
			*	-	6630	(29500)				0.96	-	6630	(29500)	8	6175DC	121	
			1.03	I	9380	(41700)				1.24	I	9130	(40600)	8	6180DB	121	
			1.22	I	9380	(41700)				1.47	II	9130	(40600)	8	6185DB	121	
			1.62	III	13300	(59000)				1.95	III	12800	(57000)	8	6190DB	121	
			1.92	III	13300	(59000)				2.05	III	12800	(57000)	8	6195DB	121	
			2.05	III	18900	(84100)				2.05	III	18900	(84100)	8	6205DB	121	
10.1	27900	(3150)	*	-	6630	(29500)	12.2	27900	(3150)	*	-	6630	(29500)	8	6175DC	143	
			1.05	I	9380	(41700)				1.27	I	9380	(41700)	8	6185DB	143	
			1.37	II	13300	(59000)				1.65	III	13300	(59000)	8	6190DB	143	
			1.64	III	13300	(59000)				1.97	III	13300	(59000)	8	6195DB	143	

Notes: All 1HP+ motors require EP suffix and can be used with a VFD, unless noted per column VFD [2].

[1] Selections with service factor marked with an asterisk (*) should be limited to the identified output torque.

[2] Variable Frequency Drive Availability:

AV = AF-motor (AV suffix) option available (does not apply to EP motors [1HP+])

C.F. = Consult Factory, VFD operation needs to be reviewed.

Selection Tables

7.5 HP
5.5 kW

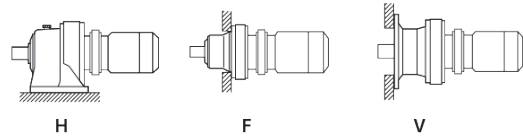

Dimension Pages:
Foot Mount (H) 2.100 - 2.129
V-Flange Mount (V) 2.130 - 2.159
F-Flange Mount (F) 2.160 - 2.189

Frequency	50 Hz	60 Hz
Input Speed	1450 RPM	1750 RPM
Number of Poles	4	

50 Hz					60 Hz					Selection							
Output Speed (RPM)	Output Torque		Service Factor ^[1]		Solid Shaft Overhung Load		Output Speed (RPM)	Output Torque		Service Factor ^[1]		Solid Shaft Overhung Load		Base			VFD ^[2]
	in-lbs	(N·m)	SF	AGMA Class	lbs	(N)		in-lbs	(N·m)	SF	AGMA Class	lbs	(N)	Motor Power Code	Frame Size	Ratio	
8.79	27900	(3150)	*	-	6630	(29500)	10.6	27900	(3150)	*	-	6630	(29500)	8	6175DC	165	
	35900	(4060)	*	-	9380	(41700)		35900	(4060)	*	-	9380	(41700)	8	6180DB	165	
	43600	(4920)	*	-	9380	(41700)		39400	(4460)	1.10	I	9380	(41700)	8	6185DB	165	
	47600	(5380)	1.19	I	13300	(59000)		1.43	II	13300	(59000)	8	6190DB	165			
			1.47	II	13300	(59000)		1.77	III	13300	(59000)	8	6195DB	165			
			1.72	III	18900	(84100)		2.05	III	18900	(84100)	8	6205DB	165			
			2.05	III	23400	(104000)		2.05	III	23400	(104000)	8	6215DA	165			
			2.26	III	23400	(104000)		2.73	III	23400	(104000)	8	6215DB	165			
			2.69	III	28000	(124000)		3.25	III	26500	(118000)	8	6225DB	165			
7.44	35900	(4060)	*	-	9380	(41700)	8.97	35900	(4060)	*	-	9380	(41700)	8	6180DB	195	
	43600	(4920)	*	-	9380	(41700)		46600	(5270)	1.08	I	13300	(59000)	8	6190DA	195	
	56300	(6360)	1.00	I	13200	(58900)		1.21	I	13300	(59000)	8	6190DB	195			
			1.00	I	13200	(58900)		1.50	II	13300	(59000)	8	6195DB	195			
			1.46	II	18900	(84100)		1.76	III	18900	(84100)	8	6205DB	195			
			1.86	III	23400	(104000)		2.05	III	23400	(104000)	8	6215DA	195			
			1.91	III	23400	(104000)		2.31	III	23400	(104000)	8	6215DB	195			
			2.28	III	29400	(131000)		2.75	III	27800	(124000)	8	6225DB	195			
6.28	44300	(5000)	*	-	9380	(41700)	7.58	44300	(5000)	*	-	9380	(41700)	8	6185DB	231	
	66700	(7530)	1.06	I	13300	(59000)		55200	(6240)	1.08	I	13300	(59000)	8	6195DA	231	
			1.06	I	13300	(59000)		1.28	I	13300	(59000)	8	6195DB	231			
			1.23	I	18900	(84100)		1.49	II	18900	(84100)	8	6205DB	231			
			1.66	III	23400	(104000)		2.00	III	23400	(104000)	8	6215DA	231			
			1.97	III	31300	(139000)		2.05	III	29600	(132000)	8	6225DA	231			
			1.97	III	31300	(139000)		2.37	III	29600	(132000)	8	6225DB	231			
			2.51	III	39000	(173000)		3.03	III	36900	(164000)	8	6235DA	231			
5.31	44300	(5000)	*	-	9380	(41700)	6.41	44300	(5000)	*	-	9380	(41700)	8	6185DB	273	
	56500	(6380)	*	-	13300	(59000)		56500	(6380)	*	-	13300	(59000)	8	6190DA	273	
	70500	(7960)	*	-	13300	(59000)		65300	(7370)	1.08	I	13300	(59000)	8	6195DA	273	
	78800	(8900)	1.04	I	18900	(84100)		1.26	I	18900	(84100)	8	6205DB	273			
			1.40	II	23400	(104000)		1.70	III	23400	(104000)	8	6215DA	273			
			1.66	III	32600	(145000)		2.01	III	31100	(138000)	8	6225DA	273			
			2.12	III	40100	(179000)		2.56	III	38800	(172000)	8	6235DA	273			
			2.90	III	45500	(203000)		3.50	III	43100	(192000)	8	6245DA	273			

Selection Tables

7.5 HP
5.5 kW

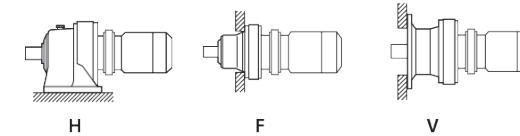

Dimension Pages:
Foot Mount (H) 2.100 - 2.129
V-Flange Mount (V) 2.130 - 2.159
F-Flange Mount (F) 2.160 - 2.189

Frequency	50 Hz	60 Hz
Input Speed	1450 RPM	1750 RPM
Number of Poles	4	

50 Hz					60 Hz					Selection							
Output Speed (RPM)	Output Torque		Service Factor ^[1]		Solid Shaft Overhung Load		Output Speed (RPM)	Output Torque		Service Factor ^[1]		Solid Shaft Overhung Load		Base			VFD ^[2]
	in-lbs	(N·m)	SF	AGMA Class	lbs	(N)		in-lbs	(N·m)	SF	AGMA Class	lbs	(N)	Motor Power Code	Frame Size	Ratio	
4.55	56500	(6380)	*	-	13300	(59000)	5.49	56500	(6380)	*	-	13300	(59000)	8	6190DA	319	
	70500	(7960)	*	-	13300	(59000)		70500	(7960)	*	-	13300	(59000)	8	6195DA	319	
	81700	(9230)	*	-	18900	(84100)		76300	(8620)	1.07	I	18900	(84100)	8	6205DB	319	
	92000	(10400)	1.22	I	23400	(104000)		1.47	II	23400	(104000)	8	6215DA	319			
			1.45	II	32600	(145000)		1.75	III	32300	(143000)	8	6225DA	319			
			1.82	III	40100	(179000)		2.19	III	40100	(179000)	8	6235DA	319			
3.85	70500	(7960)	*	-	13300	(59000)	4.64	70500	(7960)	*	-	13300	(59000)	8	6195DA	377	
	75700	(8550)	*	-	18900	(84100)		71100	(8030)	*	-	18900	(84100)	8	6205DA	377	
	109000	(12300)	1.03	I	23400	(104000)		90100	(10200)	1.24	I	23400	(104000)	8	6215DA	377	
			1.22	I	32600	(145000)		1.48	II	32600	(145000)	8	6225DA	377			
			1.54	II	40100	(179000)		1.86	III	40100	(179000)	8	6235DA	377			
			2.10	III	46800	(208000)		2.53	III	46800	(208000)	8	6245DA	377			
3.07	112000	(12700)	*	-	23400	(104000)	3.70	113000	(12800)	0.99	-	23400	(104000)	8	6215DA	473	
	136000	(15400)	1.04	I	32600	(145000)		1.25	I	32600	(145000)	8	6225DA	473			
			1.33	II	40100	(179000)		1.60	III	40100	(179000)	8	6235DA	473			
			1.67	III	46800	(208000)		2.02	III	46800	(208000)	8	6245DA	473			
			2.24	III	58000	(258000)		2.70	III	58000	(258000)	8	6255DA	473			
			2.98	III	62000	(276000)		3.60	III	62000	(276000)	8	6265DA	473			
2.59	112000	(12700)	*	-	23400	(104000)	3.13	112000	(12700)	*	-	23400	(104000)	8	6215DA	559	
	142000	(16000)	*	-	32600	(145000)		134000	(15100)	1.06	I	32600	(145000)	8	6225DA	559	
	161000	(18200)	1.12	I	40100	(179000)		1.36	II	40100	(179000)	8	6235DA	559			
			1.42	II	46800	(208000)		1.71	III	46800	(208000)	8	6245DA	559			
			1.89	III	58000	(258000)		2.28	III	58000	(258000)	8	6255DA	559			
			2.52	III	62000	(276000)		3.05	III	62000	(276000)	8	6265DA	559			
2.23	112000	(12700)	*	-	23400	(104000)	2.70	112000	(12700)	*	-	23400	(104000)	8	6215DA	649	
	141000	(15900)	*	-	32600	(145000)		141000	(15900)	*	-	32600	(145000)	8	6225DA	649	
	187000	(21200)	0.97	-	40100	(179000)		155000	(17500)	1.17	I	40100	(179000)	8	6235DA	649	
			1.22	I	46800	(208000)		1.47	II	46800	(208000)	8	6245DA	649			
			1.63	III	58000	(258000)		1.97	III	58000	(258000)	8	6255DA	649			
			2.17	III	62000	(276000)		2.62	III	62000	(276000)	8	6265DA	649			
1.98	142000	(16000)	*	-	32600	(145000)	2.39	142000	(16000)	*	-	32600	(145000)	8	6225DA	731	
	181000	(20500)	*	-	40100	(179000)		175000	(19700)	1.04	I	40100	(179000)	8	6235DA	731	
	211000	(23800)	1.08	I	46800	(208000)		1.31	II	46800	(208000)	8	6245DA	731			
			1.45	II	58000	(258000)		1.75	III	58000	(258000)	8	6255DA	731			
			1.93	III	62000	(276000)		2.33	III	62000	(276000)	8	6265DA	731			

Notes: All 1HP+ motors require EP suffix and can be used with a VFD, unless noted per column VFD [2].

[1] Selections with service factor marked with an asterisk (*) should be limited to the identified output torque.

[2] Variable Frequency Drive Availability:

AV = AF-motor (AV suffix) option available (does not apply to EP motors [1HP+])

C.F. = Consult Factory, VFD operation needs to be reviewed.

Notes: All 1HP+ motors require EP suffix and can be used with a VFD, unless noted per column VFD [2].

[1] Selections with service factor marked with an asterisk (*) should be limited to the identified output torque.

[2] Variable Frequency Drive Availability:

AV = AF-motor (AV suffix) option available (does not apply to EP motors [1HP+])

C.F. = Consult Factory, VFD operation needs to be reviewed.

Selection Tables

7.5 HP
5.5 kW

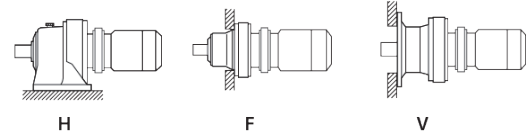

Dimension Pages:
Foot Mount (H) 2.100 - 2.129
V-Flange Mount (V) 2.130 - 2.159
F-Flange Mount (F) 2.160 - 2.189

Frequency	50 Hz	60 Hz
Input Speed	1450 RPM	1750 RPM
Number of Poles	4	

50 Hz					60 Hz					Selection							
Output Speed (RPM)	Output Torque		Service Factor ^[1]		Solid Shaft Overhung Load		Output Speed (RPM)	Output Torque		Service Factor ^[1]		Solid Shaft Overhung Load		Base			VFD ^[2]
	in-lbs	(N·m)	SF	AGMA Class	lbs	(N)		in-lbs	(N·m)	SF	AGMA Class	lbs	(N)	Motor Power Code	Frame Size	Ratio	
1.72	167000	(18900)	*	-	40100	(179000)	2.08	167000	(18900)	*	-	40100	(179000)	8	6235DA	841	C.F.
	228000	(25800)	*	-	46800	(208000)		201000	(22700)	1.14	I	46800	(208000)	8	6245DA	841	
	243000	(27400)	1.18	I	58000	(258000)		1.43	II	58000	(258000)	8	6255DA	841			
			1.68	III	62000	(276000)		2.02	III	62000	(276000)	8	6265DA	841			
1.45	181000	(20500)	*	-	40100	(179000)	1.74	181000	(20500)	*	-	40100	(179000)	8	6235DA	1003	C.F.
	228000	(25800)	*	-	46800	(208000)		228000	(25800)	*	-	46800	(208000)	8	6245DA	1003	
	289000	(32700)	1.06	I	58000	(258000)		240000	(27100)	1.27	I	58000	(258000)	8	6255DA	1003	
			1.41	II	62000	(276000)		1.70	III	62000	(276000)	8	6265DA	1003			
1.16	228000	(25800)	*	-	46800	(208000)	1.40	228000	(25800)	*	-	46800	(208000)	8	6245DA	1247	C.F.
	305000	(34500)	*	-	58000	(258000)		298000	(33700)	1.02	I	58000	(258000)	8	6255DA	1247	
	360000	(40700)	1.13	I	62000	(276000)		1.37	II	62000	(276000)	8	6265DA	1247			
0.980	274000	(31000)	*	-	58000	(258000)	1.18	274000	(31000)	*	-	58000	(258000)	8	6255DA	1479	C.F.
	390000	(44000)	*	-	62000	(276000)		354000	(40000)	1.10	I	62000	(276000)	8	6265DA	1479	C.F.
0.784	305000	(34500)	*	-	58000	(258000)	0.946	305000	(34500)	*	-	58000	(258000)	8	6255DA	1849	C.F.
	407000	(46000)	*	-	62000	(276000)		407000	(46000)	*	-	62000	(276000)	8	6265DA	1849	
0.702	407000	(46000)	*	-	62000	(276000)	0.847	407000	(46000)	*	-	62000	(276000)	8	6265DA	2065	C.F.
0.572	407000	(46000)	*	-	62000	(276000)	0.690	407000	(46000)	*	-	62000	(276000)	8	6265DA	2537	C.F.
0.476	390000	(44000)	*	-	62000	(276000)	0.575	390000	(44000)	*	-	62000	(276000)	8	6265DA	3045	C.F.
0.417	407000	(46000)	*	-	62000	(276000)	0.503	407000	(46000)	*	-	62000	(276000)	8	6265DA	3481	C.F.
0.327	390000	(44000)	*	-	62000	(276000)	0.394	390000	(44000)	*	-	62000	(276000)	8	6265DA	4437	C.F.
0.282	407000	(46000)	*	-	62000	(276000)	0.341	407000	(46000)	*	-	62000	(276000)	8	6265DA	5133	C.F.
0.235	390000	(44000)	*	-	62000	(276000)	0.283	390000	(44000)	*	-	62000	(276000)	8	6265DA	6177	C.F.
0.192	390000	(44000)	*	-	62000	(276000)	0.231	390000	(44000)	*	-	62000	(276000)	8	6265DA	7569	C.F.

Selection Tables

10 HP
7.5 kW

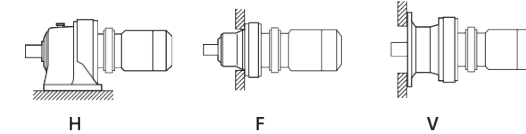

Dimension Pages:
Foot Mount (H) 2.100 - 2.129
V-Flange Mount (V) 2.130 - 2.159
F-Flange Mount (F) 2.160 - 2.189

Frequency	50 Hz	60 Hz
Input Speed	1450 RPM	1750 RPM
Number of Poles	4	

50 Hz					60 Hz					Selection							
Output Speed (RPM)	Output Torque		Service Factor ^[1]		Solid Shaft Overhung Load		Output Speed (RPM)	Output Torque		Service Factor ^[1]		Solid Shaft Overhung Load		Base			VFD ^[2]
	in-lbs	(N·m)	SF	AGMA Class	lbs	(N)		in-lbs	(N·m)	SF	AGMA Class	lbs	(N)	Motor Power Code	Frame Size	Ratio	
483	1250	(141)	1.25	I	1040	(4630)	583	1030	(117)	1.25	I	985	(4380)	10	6130	3	
			1.51	II	1040	(4630)				1.51	II	985	(4380)	10	6135	3	
			1.73	II	1640	(7300)				1.73	II	1560	(6920)	10	6140	3	
			2.01	III	1640	(7300)				2.01	III	1560	(6920)	10	6145	3	
290	2080	(235)	1.25	I	1230	(5490)	350	1720	(194)	1.25	I	1170	(5190)	10	6130	5	
			1.51	II	1230	(5490)				1.51	II	1170	(5190)	10	6135	5	
			1.73	II	1950	(8660)				1.73	II	1850	(8210)	10	6140	5	
			2.01	III	1950	(8660)				2.01	III	1850	(8210)	10	6145	5	
242	2490	(282)	1.25	I	1340	(5980)	292	2060	(233)	1.25	I	1270	(5650)	10	6130	6	
			1.51	II	1340	(5980)				1.51	II	1270	(5650)	10	6135	6	
			1.74	III	2100	(9330)				1.74	III	1990	(8830)	10	6140	6	
			2.02	III	2100	(9330)				2.02	III	1990	(8830)	10	6145	6	
181	3320	(375)	1.25	I	1500	(6650)	219	2750	(311)	1.25	I	1410	(6290)	10	6130	8	
			1.51	II	1500	(6650)				1.51	II	1410	(6290)	10	6135	8	
			1.74	III	2320	(10300)				1.74	III	2200	(9790)	10	6140	8	
			2.02	III	2320	(10300)				2.02	III	2200	(9790)	10	6145	8	
132	4570	(516)	1.25	I	1700	(7570)	159	3790	(428)	1.25	I	1610	(7150)	10	6130	11	
			1.51	II	1700	(7570)				1.51	II	1610	(7150)	10	6135	11	
			1.74	III	2610	(11600)				1.74	III	2470	(11000)	10	6140	11	
			2.02	III	2610	(11600)				2.02	III	2470	(11000)	10	6145	11	
112	5400	(610)	1.25	I	1770	(7860)	135	4470	(505)	1.25	I	1670	(7430)	10	6130	13	
			1.36	II	1770	(7860)				1.36	II	1670	(7430)	10	6135	13	
			1.74	III	2660	(11800)				1.74	III	2520	(11200)	10	6140	13	
			2.01	III	2660	(11800)				2.01	III	2520	(11200)	10	6145	13	
96.7	6230	(704)	1.04	I	1800	(8000)	117	5160	(583)	1.04	I	1700	(7570)	10	6130	15	
			1.20	I	1800	(8000)				1.20	I	1700	(7570)	10	6135	15	
			1.60	III	2780	(12400)				1.60	III	2640	(11700)	10	6140	15	
			1.93	III	2780	(12400)				1.93	III	2640	(11700)	10	6145	15	
			2.49	III	3290	(14700)				2.49	III	3100	(13800)	10	6160	15	
			2.98	III	3290	(14700)				2.98	III	3100	(13800)	10	6165	15	

Notes: All 1HP+ motors require EP suffix and can be used with a VFD, unless noted per column VFD [2].

[1] Selections with service factor marked with an asterisk (*) should be limited to the identified output torque.

[2] Variable Frequency Drive Availability:

AV = AF-motor (AV suffix) option available (does not apply to EP motors [1HP+])

C.F. = Consult Factory, VFD operation needs to be reviewed.

Notes: All 1HP+ motors require EP suffix and can be used with a VFD, unless noted per column VFD [2].

[1] Selections with service factor marked with an asterisk (*) should be limited to the identified output torque.

[2] Variable Frequency Drive Availability:

AV = AF-motor (AV suffix) option available (does not apply to EP motors [1HP+])

C.F. = Consult Factory, VFD operation needs to be reviewed.

Selection Tables

10 HP
7.5 kW

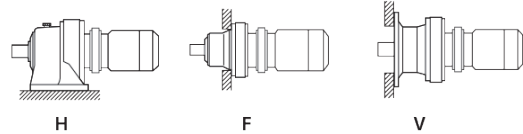

Dimension Pages:
Foot Mount (H) 2.100 - 2.129
V-Flange Mount (V) 2.130 - 2.159
F-Flange Mount (F) 2.160 - 2.189

Frequency	50 Hz	60 Hz
Input Speed	1450 RPM	1750 RPM
Number of Poles	4	

50 Hz					60 Hz					Selection							
Output Speed (RPM)	Output Torque		Service Factor ^[1]		Solid Shaft Overhung Load		Output Speed (RPM)	Output Torque		Service Factor ^[1]		Solid Shaft Overhung Load		Base			VFD ^[2]
	in-lbs	(N·m)	SF	AGMA Class	lbs	(N)		in-lbs	(N·m)	SF	AGMA Class	lbs	(N)	Motor Power Code	Frame Size	Ratio	
85.3	7060	(798)	1.11	I	1920	(8550)	103	5850	(661)	1.11	I	1820	(8100)	10	6135	17	
			1.34	II	2900	(12900)				1.34	II	2750	(12200)	10	6140	17	
			1.60	III	2900	(12900)				1.60	III	2750	(12200)	10	6145	17	
			1.74	III	3400	(15100)				1.74	III	3210	(14300)	10	6160	17	
			2.51	III	3400	(15100)				2.51	III	3210	(14300)	10	6165	17	
			2.62	III	3850	(17100)				2.62	III	3620	(16100)	10	6170	17	
69.0	8720	(985)	0.90	-	2030	(9050)	83.3	7230	(817)	1.00	I	1930	(8590)	10	6135	21	
			1.16	I	3100	(13800)				1.16	I	2940	(13100)	10	6140	21	
			1.26	I	3100	(13800)				1.46	II	2940	(13100)	10	6145	21	
			1.72	III	3640	(16200)				1.72	III	3430	(15300)	10	6160	21	
			2.13	III	3640	(16200)				2.14	III	3430	(15300)	10	6165	21	
			2.48	III	4140	(18400)				2.60	III	3900	(17400)	10	6170	21	
58.0	10400	(1170)	1.05	I	3240	(14400)	70.0	8600	(972)	1.05	I	3070	(13700)	10	6145	25	
			1.32	II	3800	(16900)				1.32	II	3590	(15900)	10	6160	25	
			1.79	III	3800	(16900)				2.01	III	3590	(15900)	10	6165	25	
			2.08	III	4280	(19100)				2.11	III	4040	(18000)	10	6170	25	
			2.60	III	4280	(19100)				2.60	III	4040	(18000)	10	6175	25	
			50.0	12000	(1360)	1.00				I	3310	(14700)	60.3	9980	(1130)	1.00	
1.27	I	3950	(17600)	1.40	II	3730	(16600)	10	6160	29							
1.52	II	3950	(17600)	1.52	II	3730	(16600)	10	6165	29							
1.79	III	4510	(20100)	1.91	III	4260	(18900)	10	6170	29							
2.31	III	4510	(20100)	2.51	III	4260	(18900)	10	6175	29							
2.60	III	6040	(26800)	2.60	III	5680	(25300)	10	6180	29							
41.4	14500	(1640)	0.83	-	3260	(14500)	50.0	12000	(1360)	1.00	I	3350	(14900)	10	6145	35	
			1.07	I	4170	(18600)				1.29	I	3940	(17500)	10	6160	35	
			1.28	I	4170	(18600)				1.52	II	3940	(17500)	10	6165	35	
			1.49	II	4770	(21200)				1.60	III	4500	(20000)	10	6170	35	
			1.92	III	4770	(21200)				2.01	III	4500	(20000)	10	6175	35	
			2.47	III	6440	(28600)				2.51	III	6060	(26900)	10	6180	35	
33.7	17900	(2020)	1.04	I	4430	(19700)	40.7	14800	(1670)	1.05	I	4190	(18600)	10	6165	43	
			1.21	I	5070	(22500)				1.30	II	4780	(21300)	10	6170	43	
			1.51	II	5070	(22500)				1.51	II	4780	(21300)	10	6175	43	
			2.01	III	6900	(30700)				2.01	III	6500	(28900)	10	6180	43	
			2.48	III	6900	(30700)				2.51	III	6500	(28900)	10	6185	43	
			2.79	III	9630	(42800)				2.79	III	9060	(40300)	10	6190	43	

Notes: All 1HP+ motors require EP suffix and can be used with a VFD, unless noted per column VFD [2].

[1] Selections with service factor marked with an asterisk (*) should be limited to the identified output torque.

[2] Variable Frequency Drive Availability:

AV = AF-motor (AV suffix) option available (does not apply to EP motors [1HP+])

C.F. = Consult Factory, VFD operation needs to be reviewed.

Selection Tables

10 HP
7.5 kW

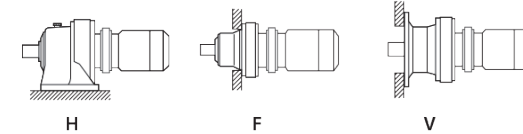

Dimension Pages:
Foot Mount (H) 2.100 - 2.129
V-Flange Mount (V) 2.130 - 2.159
F-Flange Mount (F) 2.160 - 2.189

Frequency	50 Hz	60 Hz
Input Speed	1450 RPM	1750 RPM
Number of Poles	4	

50 Hz					60 Hz					Selection											
Output Speed (RPM)	Output Torque		Service Factor ^[1]		Solid Shaft Overhung Load		Output Speed (RPM)	Output Torque		Service Factor ^[1]		Solid Shaft Overhung Load		Base			VFD ^[2]				
	in-lbs	(N·m)	SF	AGMA Class	lbs	(N)		in-lbs	(N·m)	SF	AGMA Class	lbs	(N)	Motor Power Code	Frame Size	Ratio					
28.4	21200	(2390)	0.88	-	4580	(20400)	34.3	17600	(1980)	1.00	I	4340	(19300)	10	6165	51					
			1.02	I	5260	(23400)				1.12	I	4970	(22100)	10	6170	51					
			1.32	II	5260	(23400)				1.51	II	4970	(22100)	10	6175	51					
			1.60	III	7130	(31700)				1.60	III	6720	(29900)	10	6180	51					
			2.01	III	7130	(31700)				2.01	III	6720	(29900)	10	6185	51					
			2.42	III	10100	(44800)				2.42	III	9470	(42100)	10	6190	51					
24.6	24500	(2770)	1.11	I	5500	(24400)	29.7	20300	(2290)	1.11	I	5200	(23100)	10	6175	59					
			1.30	II	7450	(33100)				1.30	II	7020	(31200)	10	6180	59					
			1.60	III	7450	(33100)				1.60	III	7020	(31200)	10	6185	59					
			2.04	III	10500	(46800)				2.04	III	9900	(44000)	10	6190	59					
			2.51	III	10500	(46800)				2.51	III	9900	(44000)	10	6195	59					
			20.4	29500	(3330)	0.93				-	5780	(25700)	24.6	24400	(2760)	0.95		-	5470	(24300)	10
1.17	I	7900	(35100)	1.17	I	7450	(33100)	10	6180	71											
1.31	II	7900	(35100)	1.31	II	7450	(33100)	10	6185	71											
1.80	III	11100	(49600)	1.80	III	10500	(46700)	10	6190	71											
2.08	III	11100	(49600)	2.08	III	10500	(46700)	10	6195	71											
16.7	36100	(4080)	1.15	I	8470	(37700)	20.1	29900	(3380)	1.15	I	7990	(35600)	10	6185	87					
1.56	II	12000	(53300)	1.57	II	11300	(50200)	10	6190	87											
1.82	III	12000	(53300)	1.82	III	11300	(50200)	10	6195	87											
13.9	40900	(4620)	1.06	I	8990	(40000)	16.8	33900	(3830)	1.28	I	8490	(37800)	10	6185DB	104					
			1.38	II	12700	(56400)				1.51	II	12000	(53200)	10	6190DB	104					
			1.51	II	12700	(56400)				1.51	II	12000	(53200)	10	6195DB	104					
12.0	35900	(4060)	*	-	9380	(41700)	14.5	35900	(4060)	*	-	9050	(40300)	10	6180DB	121					
			42500	(4810)	*	-				9380	(41700)	39400	(4460)	1.08	I	9020		(40100)	10	6185DB	121
			47600	(5380)	1.19	I				13300	(59000)	1.43	II	12700	(56600)	10		6190DB	121		
			1.41	II	13300	(59000)				1.51	II	12700	(56600)	10	6195DB	121					
			1.51	II	18900	(84100)				1.51	II	18900	(84100)	10	6205DB	121					
			2.12	III	23400	(104000)				2.55	III	23000	(102000)	10	6215DB	121					
10.1	35900	(4060)	*	-	9380	(41700)	12.2	35900	(4060)	*	-	9380	(41700)	10	6180DB	143					
			43400	(4900)	*	-				9380	(41700)	43400	(4900)	*	-	9380		(41700)	10	6185DB	143
			56300	(6360)	1.00	I				13200	(58700)	46600	(5270)	1.21	I	13200		(58800)	10	6190DB	143
			1.20	I	13200	(58700)				1.45	II	13200	(58800)	10	6195DB	143					

Notes: All 1HP+ motors require EP suffix and can be used with a VFD, unless noted per column VFD [2].

[1] Selections with service factor marked with an asterisk (*) should be limited to the identified output torque.

[2] Variable Frequency Drive Availability:

AV = AF-motor (AV suffix) option available (does not apply to EP motors [1HP+])

C.F. = Consult Factory, VFD operation needs to be reviewed.

Selection Tables

10 HP
7.5 kW

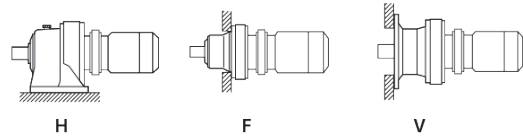

Dimension Pages:
Foot Mount (H) 2.100 - 2.129
V-Flange Mount (V) 2.130 - 2.159
F-Flange Mount (F) 2.160 - 2.189

Frequency	50 Hz	60 Hz
Input Speed	1450 RPM	1750 RPM
Number of Poles	4	

50 Hz					60 Hz					Selection							
Output Speed (RPM)	Output Torque		Service Factor ^[1]		Solid Shaft Overhung Load		Output Speed (RPM)	Output Torque		Service Factor ^[1]		Solid Shaft Overhung Load		Base			VFD ^[2]
	in-lbs	(N·m)	SF	AGMA Class	lbs	(N)		in-lbs	(N·m)	SF	AGMA Class	lbs	(N)	Motor Power Code	Frame Size	Ratio	
0.784	604000	(68200)	*	-	55700	(248000)	0.946	603000	(68100)	1.00	I	55700	(248000)	10	6275DA	1849	C.F.
0.702	604000	(68200)	*	-	55700	(248000)	0.847	604000	(68200)	*	-	55700	(248000)	10	6275DA	2065	C.F.
0.572	604000	(68200)	*	-	55700	(248000)	0.690	604000	(68200)	*	-	55700	(248000)	10	6275DA	2537	C.F.
0.476	604000	(68200)	*	-	55100	(245000)	0.575	604000	(68200)	*	-	55100	(245000)	10	6275DA	3045	C.F.
0.417	604000	(68200)	*	-	55700	(248000)	0.503	604000	(68200)	*	-	55700	(248000)	10	6275DA	3481	C.F.
0.327	604000	(68200)	*	-	55100	(245000)	0.394	604000	(68200)	*	-	55100	(245000)	10	6275DA	4437	C.F.
0.282	604000	(68200)	*	-	55100	(245000)	0.341	604000	(68200)	*	-	55100	(245000)	10	6275DA	5133	C.F.
0.235	604000	(68200)	*	-	55100	(245000)	0.283	604000	(68200)	*	-	55100	(245000)	10	6275DA	6177	C.F.
0.192	604000	(68200)	*	-	55100	(245000)	0.231	604000	(68200)	*	-	55100	(245000)	10	6275DA	7569	C.F.

Selection Tables

15 HP
11 kW

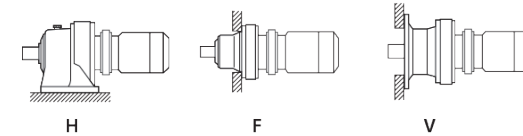

Dimension Pages:
Foot Mount (H) 2.100 - 2.129
V-Flange Mount (V) 2.130 - 2.159
F-Flange Mount (F) 2.160 - 2.189

Frequency	50 Hz	60 Hz
Input Speed	1450 RPM	1750 RPM
Number of Poles	4	

50 Hz					60 Hz					Selection							
Output Speed (RPM)	Output Torque		Service Factor ^[1]		Solid Shaft Overhung Load		Output Speed (RPM)	Output Torque		Service Factor ^[1]		Solid Shaft Overhung Load		Base			VFD ^[2]
	in-lbs	(N·m)	SF	AGMA Class	lbs	(N)		in-lbs	(N·m)	SF	AGMA Class	lbs	(N)	Motor Power Code	Frame Size	Ratio	
483	1830	(206)	1.03	I	1040	(4630)	583	1510	(171)	1.03	I	985	(4380)	15	6135	3	
			1.28	I	1640	(7300)				1.37	I	1560	(6920)	15	6145	3	
			1.85	II	1780	(7930)				1.85	II	1690	(7510)	15	6160	3	
			2.13	III	1780	(7930)				2.19	III	1690	(7510)	15	6165	3	
290	3050	(344)	1.03	I	1230	(5490)	350	2520	(285)	1.03	I	1170	(5190)	15	6135	5	
			1.37	I	1950	(8660)				1.37	I	1850	(8210)	15	6145	5	
			1.85	II	2110	(9400)				1.85	II	2000	(8900)	15	6160	5	
			2.13	III	2110	(9400)				2.19	III	2000	(8900)	15	6165	5	
242	3650	(413)	1.03	I	1310	(5840)	292	3030	(342)	1.03	I	1240	(5540)	15	6135	6	
			1.18	I	2080	(9270)				1.18	I	1970	(8780)	15	6140	6	
			1.38	II	2080	(9270)				1.38	II	1970	(8780)	15	6145	6	
			1.84	III	2330	(10400)				1.84	III	2190	(9760)	15	6160	6	
			2.19	III	2330	(10400)				2.19	III	2190	(9760)	15	6165	6	
			2.51	III	2630	(11700)				2.51	III	2470	(11000)	15	6170	6	C.F.
			2.74	III	2630	(11700)				2.74	III	2470	(11000)	15	6175	6	C.F.
181	4870	(551)	1.03	I	1460	(6480)	219	4040	(456)	1.03	I	1380	(6150)	15	6135	8	
			1.18	I	2310	(10300)				1.18	I	2190	(9730)	15	6140	8	
			1.38	II	2310	(10300)				1.38	II	2190	(9730)	15	6145	8	
			1.79	III	2600	(11600)				1.79	III	2450	(10900)	15	6160	8	
			2.19	III	2600	(11600)				2.19	III	2450	(10900)	15	6165	8	
			2.51	III	2900	(12900)				2.51	III	2730	(12200)	15	6170	8	C.F.
			2.74	III	2900	(12900)				2.74	III	2730	(12200)	15	6175	8	C.F.
132	6700	(757)	1.03	I	1650	(7360)	159	5550	(627)	1.03	I	1570	(6980)	15	6135	11	
			1.18	I	2590	(11500)				1.18	I	2450	(10900)	15	6140	11	
			1.38	II	2590	(11500)				1.38	II	2450	(10900)	15	6145	11	
			1.79	III	2940	(13100)				1.79	III	2770	(12300)	15	6160	11	
			2.19	III	2940	(13100)				2.19	III	2770	(12300)	15	6165	11	
			2.51	III	3350	(14900)				2.51	III	3150	(14000)	15	6170	11	C.F.
			2.74	III	3350	(14900)				2.74	III	3150	(14000)	15	6175	11	C.F.
112	7920	(895)	0.93	-	1710	(7630)	135	6560	(741)	1.03	I	1630	(7250)	15	6135	13	
			1.18	I	2640	(11700)				1.18	I	2500	(11100)	15	6140	13	
			1.37	II	2640	(11700)				1.37	II	2500	(11100)	15	6145	13	
			1.79	III	3080	(13700)				1.79	III	2900	(12900)	15	6160	13	
			2.05	III	3080	(13700)				2.05	III	2900	(12900)	15	6165	13	
			2.48	III	3480	(15500)				2.48	III	3280	(14600)	15	6170	13	C.F.
			2.74	III	3480	(15500)				2.74	III	3280	(14600)	15	6175	13	C.F.

Notes: All 1HP+ motors require EP suffix and can be used with a VFD, unless noted per column VFD [2].

[1] Selections with service factor marked with an asterisk (*) should be limited to the identified output torque.

[2] Variable Frequency Drive Availability:

AV = AF-motor (AV suffix) option available (does not apply to EP motors [1HP+])

C.F. = Consult Factory, VFD operation needs to be reviewed.

Notes: All 1HP+ motors require EP suffix and can be used with a VFD, unless noted per column VFD [2].

[1] Selections with service factor marked with an asterisk (*) should be limited to the identified output torque.

[2] Variable Frequency Drive Availability:

AV = AF-motor (AV suffix) option available (does not apply to EP motors [1HP+])

C.F. = Consult Factory, VFD operation needs to be reviewed.

Selection Tables

**15 HP
11 kW**

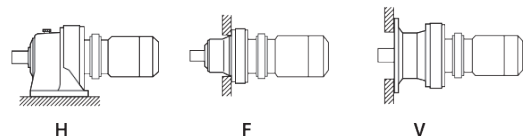

Dimension Pages:
 Foot Mount (H) 2.100 - 2.129
 V-Flange Mount (V) 2.130 - 2.159
 F-Flange Mount (F) 2.160 - 2.189

Frequency	50 Hz	60 Hz
Input Speed	1450 RPM	1750 RPM
Number of Poles	4	

50 Hz					60 Hz					Selection														
Output Speed (RPM)	Output Torque		Service Factor ^[1]		Solid Shaft Overhung Load		Output Speed (RPM)	Output Torque		Service Factor ^[1]		Solid Shaft Overhung Load		Base			VFD ^[2]							
	in-lbs	(N·m)	SF	AGMA Class	lbs	(N)		in-lbs	(N·m)	SF	AGMA Class	lbs	(N)	Motor Power Code	Frame Size	Ratio								
96.7	9140	(1030)	0.82	-	1740	(7740)	117	7570	(855)	0.82	-	1650	(7360)	15	6135	15	C.F.							
			1.09	I	2760	(12300)				1.09	I	2610	(11600)	15	6140	15								
			1.32	II	2760	(12300)				1.37	II	2610	(11600)	15	6145	15								
			1.70	III	3250	(14500)				1.70	III	3070	(13600)	15	6160	15								
			2.03	III	3250	(14500)				2.05	III	3070	(13600)	15	6165	15								
			2.32	III	3660	(16300)				2.32	III	3450	(15400)	15	6170	15								
			2.73	III	3660	(16300)				2.74	III	3450	(15400)	15	6175	15								
			2.94	III	4880	(21700)				2.94	III	4600	(20400)	15	6180	15								
85.3	10400	(1170)	1.09	I	2880	(12800)	103	8580	(969)	1.09	I	2730	(12100)	15	6145	17	C.F.							
			1.19	I	3350	(14900)				1.19	I	3160	(14100)	15	6160	17								
			1.71	III	3350	(14900)				1.71	III	3160	(14100)	15	6165	17								
			1.79	III	3800	(16900)				1.79	III	3590	(16000)	15	6170	17								
			2.19	III	3800	(16900)				2.19	III	3590	(16000)	15	6175	17								
			2.78	III	5150	(22900)				2.78	III	4850	(21600)	15	6180	17								
69.0	12800	(1450)	0.86	-	3060	(13600)	83.3	10600	(1200)	1.00	I	2910	(12900)	15	6145	21	C.F.							
			1.17	I	3580	(15900)				1.17	I	3380	(15000)	15	6160	21								
			1.45	II	3580	(15900)				1.46	II	3380	(15000)	15	6165	21								
			1.69	III	4090	(18200)				1.77	III	3860	(17200)	15	6170	21								
			2.14	III	4090	(18200)				2.19	III	3860	(17200)	15	6175	21								
			2.73	III	5510	(24500)				2.73	III	5190	(23100)	15	6180	21								
			58.0	15200	(1720)	1.22				I	3730	(16600)	70.0	12600	(1430)	1.37		II	3530	(15700)	15	6165	25	C.F.
1.42	II	4230				(18800)	1.44	II	3990	(17800)	15	6170				25								
1.77	III	4230				(18800)	1.77	III	3990	(17800)	15	6175				25								
2.19	III	5730				(25500)	2.19	III	5390	(24000)	15	6180				25								
2.74	III	5730				(25500)	2.74	III	5390	(24000)	15	6185				25								
50.0	17700	(2000)	1.04	I	3860	(17200)	60.3	14600	(1650)	1.04	I	3660	(16300)	15	6165	29	C.F.							
			1.22	I	4440	(19800)				1.30	II	4200	(18700)	15	6170	29								
			1.58	II	4440	(19800)				1.71	III	4200	(18700)	15	6175	29								
			1.77	III	5990	(26600)				1.77	III	5640	(25100)	15	6180	29								
			2.19	III	5990	(26600)				2.19	III	5640	(25100)	15	6185	29								
			2.79	III	8440	(37500)				2.79	III	7940	(35300)	15	6190	29								
			41.4	21300	(2410)	0.87				-	4060	(18100)	50.0	17700	(2000)	1.04		I	3860	(17100)	15	6165	35	C.F.
1.01	I	4690				(20900)	1.09	I	4430	(19700)	15	6170				35								
1.31	II	4690				(20900)	1.37	II	4430	(19700)	15	6175				35								
1.68	III	6380				(28400)	1.71	III	6010	(26700)	15	6180				35								
2.05	III	6380				(28400)	2.05	III	6010	(26700)	15	6185				35								
2.21	III	8910				(39600)	2.21	III	8380	(37300)	15	6190				35								
2.74	III	8910				(39600)	2.74	III	8380	(37300)	15	6195				35								
10.1	56500	(6380)				*	-	13200	(58700)	12.2	56500	(6380)				*	-	13100	(58200)	15	6190DB	143	C.F.	
						*	-	67500	(7630)							*	-	68400	(7730)	15	6195DB	143		

Notes: All 1HP+ motors require EP suffix and can be used with a VFD, unless noted per column VFD [2].
 [1] Selections with service factor marked with an asterisk (*) should be limited to the identified output torque.
 [2] Variable Frequency Drive Availability:
 AV = AF-motor (AV suffix) option available (does not apply to EP motors [1HP+])
 C.F. = Consult Factory, VFD operation needs to be reviewed.

Selection Tables

**15 HP
11 kW**

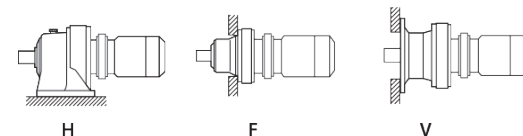

Dimension Pages:
 Foot Mount (H) 2.100 - 2.129
 V-Flange Mount (V) 2.130 - 2.159
 F-Flange Mount (F) 2.160 - 2.189

Frequency	50 Hz	60 Hz
Input Speed	1450 RPM	1750 RPM
Number of Poles	4	

50 Hz					60 Hz					Selection													
Output Speed (RPM)	Output Torque		Service Factor ^[1]		Solid Shaft Overhung Load		Output Speed (RPM)	Output Torque		Service Factor ^[1]		Solid Shaft Overhung Load		Base			VFD ^[2]						
	in-lbs	(N·m)	SF	AGMA Class	lbs	(N)		in-lbs	(N·m)	SF	AGMA Class	lbs	(N)	Motor Power Code	Frame Size	Ratio							
33.7	26200	(2960)	1.03	I	4960	(22100)	40.7	21700	(2450)	1.03	I	4700	(20900)	15	6175	43	C.F.						
			1.37	II	6820	(30300)				1.37	II	6430	(28600)	15	6180	43							
			1.69	III	6820	(30300)				1.71	III	6430	(28600)	15	6185	43							
			1.90	III	9580	(42600)				1.90	III	9010	(40100)	15	6190	43							
			2.47	III	9580	(42600)				2.74	III	9010	(40100)	15	6195	43							
			2.89	III	17500	(77700)				2.89	III	16500	(73500)	15	6205	43							
			28.4	31100	(3510)	0.90				-	5140	(22900)	34.3	25700	(2910)	1.03		I	4870	(21700)	15	6175	51
1.09	I	7050				(31300)	1.09	I	6650	(29600)	15	6180				51							
1.37	II	7050				(31300)	1.37	II	6650	(29600)	15	6185				51							
1.65	III	9990				(44400)	1.65	III	9410	(41900)	15	6190				51							
1.90	III	9990				(44400)	1.90	III	9410	(41900)	15	6195				51							
24.6	35900	(4060)	1.09	I	7350	(32700)	29.7	29800	(3360)	1.09	I	6940	(30900)	15	6185	59	C.F.						
			1.39	II	10400	(46400)				1.39	II	9830	(43700)	15	6190	59							
			1.71	III	10400	(46400)				1.71	III	9830	(43700)	15	6195	59							
			2.05	III	18900	(84100)				2.05	III	18000	(79900)	15	6205	59							
20.4	43300	(4890)	0.89	-	7770	(34500)	24.6	35800	(4050)	0.89	-	7340	(32700)	15	6185	71	C.F.						
			1.23	I	11000	(49100)				1.23	I	10400	(46300)	15	6190	71							
			1.42	II	11000	(49100)				1.42	II	10400	(46300)	15	6195	71							
16.7	53000	(5990)	1.07	I	11900	(52700)	20.1	43900	(4960)	1.07	I	11200	(49700)	15	6190	87	C.F.						
			1.24	I	11900	(52700)				1.24	I	11200	(49700)	15	6195	87							
			1.45	II	18900	(84100)				1.45	II	18900	(84100)	15	6205	87							
			1.79	III	21700	(96600)				1.95	III	20600	(91500)	15	6215	87							
13.9	35900	(4060)	*	-	9040	(40200)	16.8	35900	(4060)	*	-	8470	(37700)	15	6180DB	104	C.F.						
			*	-	43400	(4900)				* -	8390	(37300)	15	6185DB	104								
			1.03	I	12500	(55600)				1.03	I	11800	(52500)	15	6195DB	104							
			12.0	42500	(4810)	*				-	9380	(41700)	14.5	42500	(4810)	*		-	8980	(40000)	15	6185DB	121
						*				-	56500	(6380)				* -		12600	(55900)	15	6190DB	121	
69800	(7890)	0.96	-	13300	(59000)	57900	(6540)	1.03	I	12600	(55900)	15	6195DB	121	C.F.								
			1.03	I	18900				(84100)	1.03	I	18900	(84100)	15		6205DB	121						
			1.44	II	23400				(104000)	1.74	III	22900	(102000)	15		6215DB	121						
			1.71	III	25700				(114000)	2.06	III	24300	(108000)	15		6225DB	121						
10.1	56500	(6380)	*	-	13200	(58700)	12.2	56500	(6380)	*	-	13100	(58400)	15	6190DB	143	C.F.						
			* -	67500	(7630)	* -				68400	(7730)	0.99	-	13000	(57900)	15		6195DB	143				

Notes: All 1HP+ motors require EP suffix and can be used with a VFD, unless noted per column VFD [2].
 [1] Selections with service factor marked with an asterisk (*) should be limited to the identified output torque.
 [2] Variable Frequency Drive Availability:
 AV = AF-motor (AV suffix) option available (does not apply to EP motors [1HP+])
 C.F. = Consult Factory, VFD operation needs to be reviewed.

Selection Tables

**20 HP
15 kW**

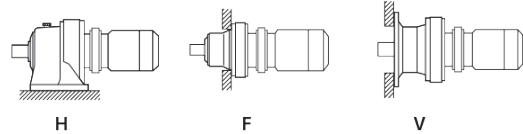

Dimension Pages:
Foot Mount (H) 2.100 - 2.129
V-Flange Mount (V) 2.130 - 2.159
F-Flange Mount (F) 2.160 - 2.189

Frequency	50 Hz	60 Hz
Input Speed	1450 RPM	1750 RPM
Number of Poles	4	

50 Hz					60 Hz					Selection							
Output Speed (RPM)	Output Torque		Service Factor ^[1]		Solid Shaft Overhung Load		Output Speed (RPM)	Output Torque		Service Factor ^[1]		Solid Shaft Overhung Load		Base			VFD ^[2]
	in-lbs	(N·m)	SF	AGMA Class	lbs	(N)		in-lbs	(N·m)	SF	AGMA Class	lbs	(N)	Motor Power Code	Frame Size	Ratio	
483	2490	(282)	0.94	-	1640	(7300)	583	2060	(233)	1.01	I	1560	(6920)	20	6145	3	
			1.35	I	1780	(7930)				20	6160	3					
			1.56	II	1780	(7930)				20	6165	3					
			1.84	II	2020	(8970)				20	6170	3					
290	4150	(469)	1.01	I	1950	(8660)	350	3440	(389)	1.01	I	1850	(8210)	20	6145	5	
			1.35	I	2110	(9400)				20	6160	5					
			1.56	II	2110	(9400)				20	6165	5					
			1.84	II	2390	(10600)				20	6170	5					
242	4980	(563)	1.01	I	2070	(9200)	292	4130	(467)	1.01	I	1960	(8730)	20	6145	6	
			1.35	II	2300	(10200)				20	6160	6					
			1.60	III	2300	(10200)				20	6165	6					
			1.84	III	2610	(11600)				20	6170	6					
			2.01	III	2610	(11600)				20	6175	6					
181	6650	(751)	1.01	I	2290	(10200)	219	5510	(622)	1.01	I	2170	(9660)	20	6145	8	
			1.31	II	2570	(11400)				20	6160	8					
			1.60	III	2570	(11400)				20	6165	8					
			1.84	III	2880	(12800)				20	6170	8					
			2.01	III	2880	(12800)				20	6175	8					
132	9140	(1030)	1.01	I	2560	(11400)	159	7570	(855)	1.01	I	2430	(10800)	20	6145	11	
			1.31	II	2900	(12900)				20	6160	11					
			1.60	III	2900	(12900)				20	6165	11					
			1.84	III	3310	(14700)				20	6170	11					
			2.01	III	3310	(14700)				20	6175	11					
			2.35	III	4420	(19600)				20	6180	11	C.F.				
			2.60	III	4420	(19600)				20	6185	11	C.F.				
2.73	III	6170	(27500)	20	6190	11	C.F.										
112	10800	(1220)	1.00	I	2610	(11600)	135	8950	(1010)	1.00	I	2480	(11000)	20	6145	13	
			1.31	II	3030	(13500)				20	6160	13					
			1.51	II	3030	(13500)				20	6165	13					
			1.82	III	3440	(15300)				20	6170	13					
			2.01	III	3440	(15300)				20	6175	13					
			2.35	III	4590	(20400)				20	6180	13	C.F.				
			2.60	III	4590	(20400)				20	6185	13	C.F.				
			2.73	III	6430	(28600)				20	6190	13	C.F.				

Notes: All 1HP+ motors require EP suffix and can be used with a VFD, unless noted per column VFD [2].

[1] Selections with service factor marked with an asterisk (*) should be limited to the identified output torque.

[2] Variable Frequency Drive Availability:

AV = AF-motor (AV suffix) option available (does not apply to EP motors [1HP+])

C.F. = Consult Factory, VFD operation needs to be reviewed.

Selection Tables

**20 HP
15 kW**

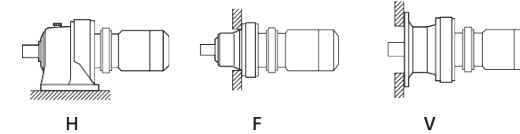

Dimension Pages:
Foot Mount (H) 2.100 - 2.129
V-Flange Mount (V) 2.130 - 2.159
F-Flange Mount (F) 2.160 - 2.189

Frequency	50 Hz	60 Hz
Input Speed	1450 RPM	1750 RPM
Number of Poles	4	

50 Hz					60 Hz					Selection							
Output Speed (RPM)	Output Torque		Service Factor ^[1]		Solid Shaft Overhung Load		Output Speed (RPM)	Output Torque		Service Factor ^[1]		Solid Shaft Overhung Load		Base			VFD ^[2]
	in-lbs	(N·m)	SF	AGMA Class	lbs	(N)		in-lbs	(N·m)	SF	AGMA Class	lbs	(N)	Motor Power Code	Frame Size	Ratio	
96.7	12500	(1410)	0.96	-	2730	(12100)	117	10300	(1170)	1.00	I	2590	(11500)	20	6145	15	
			1.25	I	3200	(14200)				20	6160	15					
			1.49	II	3200	(14200)				20	6165	15					
			1.70	III	3610	(16100)				20	6170	15					
			2.01	III	3610	(16100)				20	6175	15					
			2.16	III	4850	(21600)				20	6180	15	C.F.				
			2.60	III	4850	(21600)				20	6185	15	C.F.				
2.73	III	6750	(30000)	20	6190	15	C.F.										
85.3	14100	(1600)	0.80	-	2840	(12600)	103	11700	(1320)	0.80	-	2700	(12000)	20	6145	17	
			0.87	-	3290	(14600)				20	6160	17					
			1.26	I	3290	(14600)				20	6165	17					
			1.31	II	3750	(16700)				20	6170	17					
			1.60	III	3750	(16700)				20	6175	17					
			2.04	III	5110	(22700)				20	6180	17					
			2.55	III	5110	(22700)				20	6185	17	C.F.				
2.73	III	7110	(31600)	20	6190	17	C.F.										
69.0	17400	(1970)	1.07	I	3500	(15600)	83.3	14500	(1630)	1.07	I	3320	(14800)	20	6165	21	
			1.24	I	4030	(17900)				20	6170	21					
			1.57	II	4030	(17900)				20	6175	21					
			2.00	III	5470	(24300)				20	6180	21					
			2.54	III	5470	(24300)				20	6185	21					
			2.73	III	7640	(34000)				20	6190	21	C.F.				
58.0	20800	(2350)	0.90	-	3630	(16200)	70.0	17200	(1940)	1.00	I	3450	(15400)	20	6165	25	
			1.04	I	4160	(18500)				20	6170	25					
			1.30	II	4160	(18500)				20	6175	25					
			1.60	III	5680	(25300)				20	6180	25					
			2.01	III	5680	(25300)				20	6185	25					
			2.35	III	7990	(35600)				20	6190	25	C.F.				
			2.70	III	7990	(35600)				20	6195	25	C.F.				
50.0	24100	(2720)	1.16	I	4360	(19400)	60.3	20000	(2260)	1.26	I	4130	(18400)	20	6175	29	
			1.30	II	5930	(26400)				20	6180	29					
			1.60	III	5930	(26400)				20	6185	29					
			2.05	III	8400	(37400)				20	6190	29					
			2.52	III	8400	(37400)				20	6195	29					
			1.16	I	4360	(19400)				20	6175	29					
			1.30	II	5930	(26400)				20	6180	29					
1.60	III	5930	(26400)	20	6185	29											
2.05	III	8400	(37400)	20	6190	29											
2.52	III	8400	(37400)	20	6195	29											
41.4	29100	(3280)	0.96	-	4590	(20400)	50.0	24100	(2720)	1.00	I	4350	(19400)	20	6175	35	
			1.23	I	6310	(28100)				20	6180	35					
			1.51	II	6310	(28100)				20	6185	35					
			1.62	III	8850	(39400)				20	6190	35					
			2.01	III	8850	(39400)				20	6195	35					

Notes: All 1HP+ motors require EP suffix and can be used with a VFD, unless noted per column VFD [2].

[1] Selections with service factor marked with an asterisk (*) should be limited to the identified output torque.

[2] Variable Frequency Drive Availability:

AV = AF-motor (AV suffix) option available (does not apply to EP motors [1HP+])

C.F. = Consult Factory, VFD operation needs to be reviewed.

Selection Tables

20 HP
15 kW

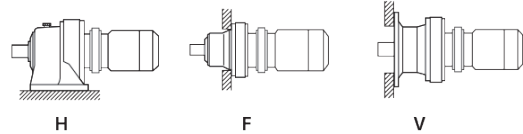

Dimension Pages:
Foot Mount (H) 2.100 - 2.129
V-Flange Mount (V) 2.130 - 2.159
F-Flange Mount (F) 2.160 - 2.189

Frequency	50 Hz	60 Hz
Input Speed	1450 RPM	1750 RPM
Number of Poles	4	

50 Hz					60 Hz					Selection							
Output Speed (RPM)	Output Torque		Service Factor ^[1]		Solid Shaft Overhung Load		Output Speed (RPM)	Output Torque		Service Factor ^[1]		Solid Shaft Overhung Load		Base			VFD ^[2]
	in-lbs	(N·m)	SF	AGMA Class	lbs	(N)		in-lbs	(N·m)	SF	AGMA Class	lbs	(N)	Motor Power Code	Frame Size	Ratio	
33.7	35700	(4040)	1.00	I	6720	(29900)	40.7	29600	(3340)	1.00	I	6360	(28300)	20	6180	43	C.F.
			1.24	I	6720	(29900)				1.26	I	6360	(28300)				
			1.40	II	9510	(42300)				1.40	II	8960	(39900)				
			1.81	III	9510	(42300)				2.01	III	8960	(39900)				
			2.12	III	17400	(77500)				2.12	III	16500	(73300)				
28.4	42400	(4790)	1.00	I	6940	(30900)	34.3	35100	(3970)	1.00	I	6560	(29200)	20	6185	51	C.F.
			1.21	I	9900	(44100)				1.21	I	9340	(41500)				
			1.40	II	9900	(44100)				1.40	II	9340	(41500)				
24.6	49000	(5540)	0.80	-	7220	(32100)	29.7	40600	(4590)	0.80	-	6840	(30400)	20	6185	59	C.F.
			1.02	I	10400	(46000)				1.02	I	9760	(43400)				
			1.26	I	10400	(46000)				1.26	I	9760	(43400)				
			1.51	II	18900	(84100)				1.51	II	17900	(79700)				
			2.26	III	19300	(85900)				2.51	III	18300	(81300)				
20.4	59000	(6660)	1.04	I	10900	(48600)	24.6	48900	(5520)	1.04	I	10300	(45900)	20	6195	71	C.F.
			1.06	I	18900	(84100)				1.06	I	18900	(84100)				
16.7	72300	(8170)	0.91	-	11700	(52100)	20.1	59900	(6770)	0.91	-	11100	(49200)	20	6195	87	C.F.
			1.06	I	18900	(84100)				1.06	I	18900	(84100)				
			1.31	II	21600	(96100)				1.43	II	20500	(91000)				
13.9	56500	(6380)	*	-	12500	(55800)	16.8	51100	(5770)	*	-	11800	(52500)	20	6190DB	104	C.F.
			*	-	12500	(55600)				*	-	11800	(52500)				
12.0	67100	(7580)	*	-	13300	(59000)	14.5	59400	(6720)	*	-	12500	(55800)	20	6195DB	121	C.F.
			*	-	18900	(84100)				*	-	18900	(84100)				
			1.06	I	23400	(104000)				1.28	I	22800	(101000)				
			1.25	I	25500	(113000)				1.51	II	24200	(108000)				
			1.60	III	32000	(142000)				1.60	III	30300	(135000)				
			1.74	III	32000	(142000)				2.10	III	30300	(135000)				
			1.91	III	35600	(159000)				2.30	III	33700	(150000)				
			2.56	III	43700	(194000)				3.08	III	41300	(184000)				
			2.91	III	53400	(237000)				3.21	III	50500	(225000)				
			8.79	82000	(9270)	*				-	18900	(84100)	10.6				
97800	(11100)	*	-	23400	(104000)	*	-	23400	(104000)								
108000	(12200)	*	-	23400	(104000)	1.00	I	23400	(104000)								
130000	(14700)	0.99	-	27500	(122000)	1.19	I	26100	(116000)								
		1.34	II	34200	(152000)	1.60	III	32400	(144000)								
		1.60	III	38300	(170000)	1.60	III	36200	(161000)								
		1.79	III	38300	(170000)	2.16	III	36200	(161000)								
		2.12	III	46900	(209000)	2.56	III	44400	(197000)								
		2.98	III	57200	(254000)	3.21	III	54100	(241000)								

Notes: All 1HP+ motors require EP suffix and can be used with a VFD, unless noted per column VFD [2].

[1] Selections with service factor marked with an asterisk (*) should be limited to the identified output torque.

[2] Variable Frequency Drive Availability:

AV = AF-motor (AV suffix) option available (does not apply to EP motors [1HP+])

C.F. = Consult Factory, VFD operation needs to be reviewed.

Selection Tables

20 HP
15 kW

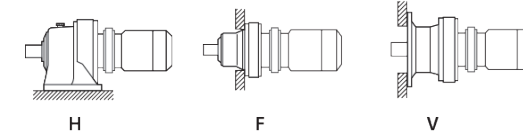

Dimension Pages:
Foot Mount (H) 2.100 - 2.129
V-Flange Mount (V) 2.130 - 2.159
F-Flange Mount (F) 2.160 - 2.189

Frequency	50 Hz	60 Hz
Input Speed	1450 RPM	1750 RPM
Number of Poles	4	

50 Hz					60 Hz					Selection																	
Output Speed (RPM)	Output Torque		Service Factor ^[1]		Solid Shaft Overhung Load		Output Speed (RPM)	Output Torque		Service Factor ^[1]		Solid Shaft Overhung Load		Base			VFD ^[2]										
	in-lbs	(N·m)	SF	AGMA Class	lbs	(N)		in-lbs	(N·m)	SF	AGMA Class	lbs	(N)	Motor Power Code	Frame Size	Ratio											
7.44	105000	(11800)	*	-	23400	(104000)	8.97	95800	(10800)	*	-	23400	(104000)	20	6215DA	195	C.F.										
			*	-	29100	(129000)				*	-	27500	(122000)														
			*	-	29000	(129000)				1.01	I	27300	(122000)														
			1.13	I	35900	(160000)				1.37	II	34000	(151000)														
			1.51	II	40100	(179000)				1.51	II	38000	(169000)														
			1.51	II	40100	(179000)				1.83	III	38000	(169000)														
			1.80	III	49200	(219000)				2.01	III	46600	(207000)														
6.28	131000	(14800)	*	-	30900	(137000)	7.58	113000	(12800)	*	-	29300	(130000)	20	6225DA	231	C.F.										
			*	-	38500	(171000)				1.11	I	36400	(162000)														
			1.26	I	42800	(190000)				1.52	II	40500	(180000)														
			1.51	II	52300	(232000)				1.82	III	49500	(220000)														
			2.24	III	62000	(276000)				2.70	III	60500	(269000)														
			5.31	167000	(18900)	*				-	40100	(179000)	6.41					167000	(18900)	*	-	38200	(170000)	20	6235DA	273	C.F.
			215000	(24300)	1.06	I				44900	(200000)	1.28								I	42500	(189000)					
		1.28	I	54800	(244000)	1.54	II	51900	(231000)																		
4.55	167000	(18900)	*	-	40100	(179000)	5.49	167000	(18900)	*	-	39800	(177000)	20	6235DA	319	C.F.										
			*	-	46800	(208000)				1.10	I	44300	(197000)														
			1.14	I	57600	(256000)				1.38	II	54600	(243000)														
			1.62	III	62000	(276000)				1.96	III	62000	(276000)														
			2.40	III	55700	(248000)				2.90	III	55700	(248000)														
3.85	228000	(25800)	*	-	46800	(208000)	4.64	228000	(25800)	*	-	46500	(207000)	20	6245DA	377	C.F.										
			0.97	-	58000	(258000)				1.17	I	57300	(255000)														
			1.37	II	62000	(276000)				1.66	III	62000	(276000)														
			2.03	III	55700	(248000)				2.46	III	55700	(248000)														
3.07	228000	(25800)	*	-	46800	(208000)	3.70	228000	(25800)	*	-	46800	(208000)	20	6245DA	473	C.F.										
			*	-	58000	(258000)				0.99	-	58000	(258000)														
			*	-	58000	(258000)				0.99	-	58000	(258000)														
			1.09	I	62000	(276000)				1.32	II	62000	(276000)														
2.59	305000	(34500)	*	-	58000	(258000)	3.13	305000	(34500)	*	-	58000	(258000)	20	6255DA	559	C.F.										
			*	-	62000	(276000)				1.12	I	62000	(276000)														
			1.37	II	55700	(248000)				1.66	III	55700	(248000)														
			2.23	407000	(46000)	*				-	62000	(276000)	2.70					423000	(47800)	0.96	-	62000	(276000)	20	6265DA	649	C.F.
511000	(57700)	1.18	I	55700	(248000)	1.43	II	55700	(248000)																		
1.98	407000	(46000)	*	-	62000	(276000)	2.39	407000	(46000)	*	-	62000	(276000)	20	6265DA	731	C.F.										
			575000	(65000)	1.05	I				55700	(248000)	1.27	I					55700	(248000)								

Notes: All 1HP+ motors require EP suffix and can be used with a VFD, unless noted per column VFD [2].

[1] Selections with service factor marked with an asterisk (*) should be limited to the identified output torque.

[2] Variable Frequency Drive Availability:

AV = AF-motor (AV suffix) option available (does not apply to EP motors [1HP+])

C.F. = Consult Factory, VFD operation needs to be reviewed.

Selection Tables

20 HP
15 kW

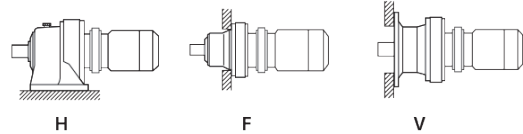

Dimension Pages:
Foot Mount (H) 2.100 - 2.129
V-Flange Mount (V) 2.130 - 2.159
F-Flange Mount (F) 2.160 - 2.189

Frequency	50 Hz	60 Hz
Input Speed	1450 RPM	1750 RPM
Number of Poles	4	

50 Hz					60 Hz					Selection							
Output Speed (RPM)	Output Torque		Service Factor ^[1]		Solid Shaft Overhung Load		Output Speed (RPM)	Output Torque		Service Factor ^[1]		Base			VFD ^[2]		
	in-lbs	(N·m)	SF	AGMA Class	lbs	(N)		in-lbs	(N·m)	SF	AGMA Class	lbs	(N)	Motor Power Code		Frame Size	Ratio
1.72	407000	(46000)	*	-	62000	(276000)	2.08	407000	(46000)	*	-	62000	(276000)	20	6265DA	841	
	604000	(68200)	*	-	55700	(248000)		548000	(62000)	1.10	I	55700	(248000)	20	6275DA	841	
1.45	604000	(68200)	*	-	55700	(248000)	1.74	604000	(68200)	*	-	55700	(248000)	20	6275DA	1003	C.F.
1.16	604000	(68200)	*	-	55700	(248000)	1.40	604000	(68200)	*	-	55700	(248000)	20	6275DA	1247	

Selection Tables

25 HP
18.5 kW

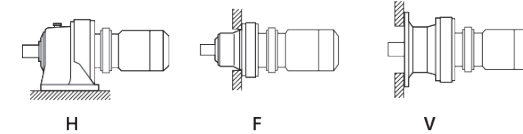

Dimension Pages:
Foot Mount (H) 2.100 - 2.129
V-Flange Mount (V) 2.130 - 2.159
F-Flange Mount (F) 2.160 - 2.189

Frequency	50 Hz	60 Hz
Input Speed	1450 RPM	1750 RPM
Number of Poles	4	

50 Hz					60 Hz					Selection								
Output Speed (RPM)	Output Torque		Service Factor ^[1]		Solid Shaft Overhung Load		Output Speed (RPM)	Output Torque		Service Factor ^[1]		Base			VFD ^[2]			
	in-lbs	(N·m)	SF	AGMA Class	lbs	(N)		in-lbs	(N·m)	SF	AGMA Class	lbs	(N)	Motor Power Code		Frame Size	Ratio	
483	3070	(347)	1.10	I	1780	(7930)	583	2550	(288)	1.10	I	1690	(7510)	25	6160	3		
			1.26	I	1780	(7930)				1.30	I	1690	(7510)	25	6165	3		
			1.49	II	2020	(8970)				1.49	II	1910	(8490)	25	6170	3		
			1.63	II	2020	(8970)				1.63	II	1910	(8490)	25	6175	3		
290	5120	(579)	1.10	I	2110	(9400)	350	4240	(480)	1.10	I	2000	(8900)	25	6160	5		
			1.26	I	2110	(9400)				1.30	I	2000	(8900)	25	6165	5		
			1.49	II	2390	(10600)				1.49	II	2260	(10100)	25	6170	5		
			1.63	II	2390	(10600)				1.63	II	2260	(10100)	25	6175	5		
242	6150	(695)	1.10	I	2280	(10200)	292	5090	(575)	1.10	I	2160	(9590)	25	6160	6		
			1.30	II	2280	(10200)				1.30	II	2160	(9590)	25	6165	6		
			1.49	II	2590	(11500)				1.49	II	2440	(10900)	25	6170	6		
			1.63	III	2590	(11500)				1.63	III	2440	(10900)	25	6175	6		
181	8200	(926)	1.06	I	2540	(11300)	219	6790	(767)	1.06	I	2400	(10700)	25	6160	8		
			1.30	II	2540	(11300)				1.30	II	2400	(10700)	25	6165	8		
			1.49	II	2860	(12700)				1.49	II	2700	(12000)	25	6170	8		
			1.63	III	2860	(12700)				1.63	III	2700	(12000)	25	6175	8		
132	11300	(1270)	1.06	I	2870	(12700)	159	9340	(1060)	1.06	I	2710	(12100)	25	6160	11		
			1.30	II	2870	(12700)				1.30	II	2710	(12100)	25	6165	11		
			1.49	II	3280	(14600)				1.49	II	3100	(13800)	25	6170	11		
			1.63	III	3280	(14600)				1.63	III	3100	(13800)	25	6175	11		
			1.90	III	4390	(19500)				1.90	III	4140	(18400)	25	6180	11		
			2.11	III	4390	(19500)				2.11	III	4140	(18400)	25	6185	11		
			2.22	III	6150	(27400)				2.22	III	5790	(25800)	25	6190	11		C.F.
2.60	III	6150	(27400)	2.60	III	5790	(25800)	25	6195	11	C.F.							
112	13300	(1500)	1.06	I	2990	(13300)	135	11000	(1250)	1.06	I	2830	(12600)	25	6160	13		
			1.22	I	2990	(13300)				1.22	I	2830	(12600)	25	6165	13		
			1.47	II	3410	(15200)				1.47	II	3220	(14300)	25	6170	13		
			1.63	III	3410	(15200)				1.63	III	3220	(14300)	25	6175	13		
			1.90	III	4570	(20300)				1.90	III	4300	(19100)	25	6180	13		
			2.11	III	4570	(20300)				2.11	III	4300	(19100)	25	6185	13		
			2.22	III	6400	(28500)				2.22	III	6030	(26800)	25	6190	13		C.F.
			2.60	III	6400	(28500)				2.60	III	6030	(26800)	25	6195	13		C.F.

Notes: All 1HP+ motors require EP suffix and can be used with a VFD, unless noted per column VFD [2].

[1] Selections with service factor marked with an asterisk (*) should be limited to the identified output torque.

[2] Variable Frequency Drive Availability:

AV = AF-motor (AV suffix) option available (does not apply to EP motors [1HP+])

C.F. = Consult Factory, VFD operation needs to be reviewed.

Notes: All 1HP+ motors require EP suffix and can be used with a VFD, unless noted per column VFD [2].

[1] Selections with service factor marked with an asterisk (*) should be limited to the identified output torque.

[2] Variable Frequency Drive Availability:

AV = AF-motor (AV suffix) option available (does not apply to EP motors [1HP+])

C.F. = Consult Factory, VFD operation needs to be reviewed.

Selection Tables

25 HP
18.5 kW

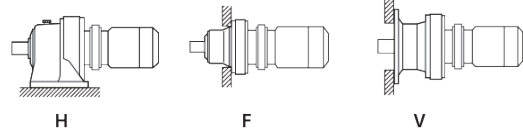

Dimension Pages:
Foot Mount (H) 2.100 - 2.129
V-Flange Mount (V) 2.130 - 2.159
F-Flange Mount (F) 2.160 - 2.189

Frequency	50 Hz	60 Hz
Input Speed	1450 RPM	1750 RPM
Number of Poles	4	

50 Hz					60 Hz					Selection							
Output Speed (RPM)	Output Torque		Service Factor ^[1]		Solid Shaft Overhung Load		Output Speed (RPM)	Output Torque		Service Factor ^[1]		Solid Shaft Overhung Load		Base			VFD ^[2]
	in-lbs	(N·m)	SF	AGMA Class	lbs	(N)		in-lbs	(N·m)	SF	AGMA Class	lbs	(N)	Motor Power Code	Frame Size	Ratio	
96.7	15400	(1740)	1.01	I	3150	(14000)	117	12700	(1440)	1.01	I	2990	(13300)	25	6160	15	C.F.
			1.21	I	3150	(14000)				1.22	I	2990	(13300)	25	6165	15	
			1.38	II	3560	(15800)				1.38	II	3370	(15000)	25	6170	15	
			1.63	III	3560	(15800)				1.63	III	3370	(15000)	25	6175	15	
			1.75	III	4810	(21400)				1.75	III	4540	(20200)	25	6180	15	
			2.11	III	4810	(21400)				2.11	III	4540	(20200)	25	6185	15	
			2.22	III	6720	(29900)				2.22	III	6330	(28100)	25	6190	15	
			2.60	III	6720	(29900)				2.60	III	6330	(28100)	25	6195	15	
85.3	17400	(1970)	1.02	I	3230	(14400)	103	14400	(1630)	1.02	I	3070	(13600)	25	6165	17	C.F.
			1.06	I	3700	(16500)				1.06	I	3500	(15600)	25	6170	17	
			1.30	II	3700	(16500)				1.30	II	3500	(15600)	25	6175	17	
			1.65	III	5070	(22600)				1.65	III	4790	(21300)	25	6180	17	
			2.06	III	5070	(22600)				2.11	III	4790	(21300)	25	6185	17	
			2.22	III	7080	(31500)				2.22	III	6670	(29700)	25	6190	17	
			2.60	III	7080	(31500)				2.60	III	6670	(29700)	25	6195	17	
			69.0	21500	(2430)	0.86				-	3430	(15300)	83.3	17800	(2010)	0.87	
1.00	I	3980				(17700)	1.05	I	3770	(16800)	25	6170				21	
1.27	I	3980				(17700)	1.30	II	3770	(16800)	25	6175				21	
1.62	III	5440				(24200)	1.62	III	5130	(22800)	25	6180				21	
2.06	III	5440				(24200)	2.11	III	5130	(22800)	25	6185				21	
2.22	III	7620				(33900)	2.22	III	7170	(31900)	25	6190				21	
2.60	III	7620				(33900)	2.60	III	7170	(31900)	25	6195				21	
58.0	25600	(2890)				1.05	I	4100	(18200)	70.0	21200	(2400)				1.05	I
			1.30	II	5640	(25100)	1.30	II	5320				(23700)	25	6180	25	
			1.63	III	5640	(25100)	1.63	III	5320				(23700)	25	6185	25	
			1.90	III	7960	(35400)	1.90	III	7500				(33300)	25	6190	25	
			2.19	III	7960	(35400)	2.19	III	7500				(33300)	25	6195	25	
50.0	29700	(3360)	0.94	-	4280	(19000)	60.3	24600	(2780)	1.02	I	4070	(18100)	25	6175	29	C.F.
			1.05	I	5880	(26100)				1.05	I	5550	(24700)	25	6180	29	
			1.30	II	5880	(26100)				1.30	II	5550	(24700)	25	6185	29	
			1.66	III	8360	(37200)				1.66	III	7870	(35000)	25	6190	29	
			2.04	III	8360	(37200)				2.04	III	7870	(35000)	25	6195	29	
			2.47	III	15400	(68700)				2.47	III	14600	(65000)	25	6205	29	
41.4	35900	(4050)	1.00	I	6250	(27800)	50.0	29700	(3360)	1.02	I	5910	(26300)	25	6180	35	C.F.
			1.22	I	6250	(27800)				1.22	I	5910	(26300)	25	6185	35	
			1.31	II	8810	(39200)				1.31	II	8300	(36900)	25	6190	35	
			1.63	III	8810	(39200)				1.63	III	8300	(36900)	25	6195	35	

Notes: All 1HP+ motors require EP suffix and can be used with a VFD, unless noted per column VFD [2].
 [1] Selections with service factor marked with an asterisk (*) should be limited to the identified output torque.
 [2] Variable Frequency Drive Availability:
 AV = AF-motor (AV suffix) option available (does not apply to EP motors [1HP+])
 C.F. = Consult Factory, VFD operation needs to be reviewed.

Selection Tables

25 HP
18.5 kW

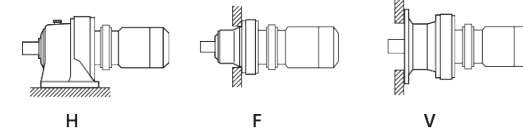

Dimension Pages:
Foot Mount (H) 2.100 - 2.129
V-Flange Mount (V) 2.130 - 2.159
F-Flange Mount (F) 2.160 - 2.189

Frequency	50 Hz	60 Hz
Input Speed	1450 RPM	1750 RPM
Number of Poles	4	

50 Hz					60 Hz					Selection							
Output Speed (RPM)	Output Torque		Service Factor ^[1]		Solid Shaft Overhung Load		Output Speed (RPM)	Output Torque		Service Factor ^[1]		Solid Shaft Overhung Load		Base			VFD ^[2]
	in-lbs	(N·m)	SF	AGMA Class	lbs	(N)		in-lbs	(N·m)	SF	AGMA Class	lbs	(N)	Motor Power Code	Frame Size	Ratio	
33.7	44100	(4980)	1.00	I	6640	(29500)	40.7	36500	(4120)	1.02	I	6290	(28000)	25	6185	43	C.F.
			1.13	I	9450	(42000)				1.13	I	8910	(39600)	25	6190	43	
			1.47	II	9450	(42000)				1.63	III	8910	(39600)	25	6195	43	
			1.72	III	17400	(77300)				1.72	III	16500	(73200)	25	6205	43	
			2.44	III	17700	(78900)				2.44	III	16800	(74700)	25	6215	43	
			2.84	III	52200	(5900)				0.81	-	6490	(28900)	25	6185	51	
24.6	60400	(6830)	1.02	I	10300	(45700)	29.7	50100	(5660)	1.02	I	9690	(43100)	25	6195	59	C.F.
			1.22	I	18900	(83900)				1.22	I	17900	(79400)	25	6205	59	
			1.83	III	19200	(85600)				2.04	III	18200	(81100)	25	6215	59	
			2.13	III	20400	(90800)				2.44	III	19300	(86000)	25	6225	59	
			2.04	III	72700	(8220)				0.84	-	10200	(45500)	25	6195	71	
16.7	89100	(10100)	1.06	I	21500	(95600)	20.1	73900	(8340)	1.16	I	20400	(90600)	25	6215	87	C.F.
			1.45	II	22800	(101000)				1.45	II	21600	(96100)	25	6225	87	
12.0	101000	(11400)	*	-	23400	(104000)	14.5	97300	(11000)	1.03	I	22600	(101000)	25	6215DB	121	C.F.
			1.01	I	25400	(113000)				1.22	I	24100	(107000)	25	6225DB	121	
			1.30	II	31900	(142000)				1.30	II	30200	(134000)	25	6235DA	121	
			1.41	II	31900	(142000)				1.70	III	30200	(134000)	25	6235DB	121	
			1.55	II	35500	(158000)				1.87	III	33600	(150000)	25	6245DB	121	
			2.07	III	43600	(194000)				2.50	III	41300	(184000)	25	6255DB	121	
			2.36	III	53300	(237000)				2.60	III	50400	(224000)	25	6265DA	121	
			8.79	128000	(14500)	*				-	27500	(122000)	10.6	133000	(15000)	0.97	
160000	(18100)	1.08	I	34100	(151000)	1.30	II	32300	(144000)	25	6235DA	165					
1.30	II	38100	(170000)	1.30	II	36100	(161000)	25	6245DA	165							
1.45	II	38100	(170000)	1.75	III	36100	(161000)	25	6245DB	165							
1.72	III	46800	(208000)	2.08	III	44300	(197000)	25	6255DB	165							
2.42	III	57100	(254000)	2.60	III	54000	(240000)	25	6265DA	165							
7.44	174000	(19600)	*	-	35800	(159000)	8.97	157000	(17700)	1.11	I	33900	(151000)	25	6235DA	195	C.F.
			1.22	I	40000	(178000)				1.22	I	37900	(169000)	25	6245DA	195	
			1.23	I	40000	(178000)				1.48	II	37900	(169000)	25	6245DB	195	
			1.46	II	49100	(218000)				1.63	III	46500	(207000)	25	6255DA	195	
			1.46	II	49100	(218000)				1.76	III	46500	(207000)	25	6255DB	195	
			2.05	III	59900	(267000)				2.47	III	56700	(252000)	25	6265DA	195	
			6.28	167000	(18900)	*				-	38500	(171000)	7.58	167000	(18900)	*	
224000	(25300)	1.02	I	42600	(189000)	1.23	I	40400	(180000)	25	6245DA	231					
1.22	I	52100	(232000)	1.48	II	49300	(219000)	25	6255DA	231							
1.82	III	62000	(276000)	2.19	III	60400	(269000)	25	6265DA	231							

Notes: All 1HP+ motors require EP suffix and can be used with a VFD, unless noted per column VFD [2].
 [1] Selections with service factor marked with an asterisk (*) should be limited to the identified output torque.
 [2] Variable Frequency Drive Availability:
 AV = AF-motor (AV suffix) option available (does not apply to EP motors [1HP+])
 C.F. = Consult Factory, VFD operation needs to be reviewed.

Selection Tables

25 HP
18.5 kW

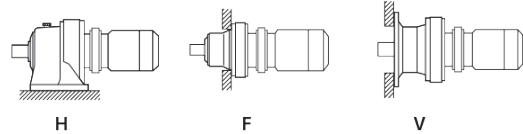

Dimension Pages:
Foot Mount (H) 2.100 - 2.129
V-Flange Mount (V) 2.130 - 2.159
F-Flange Mount (F) 2.160 - 2.189

Frequency	50 Hz	60 Hz
Input Speed	1450 RPM	1750 RPM
Number of Poles	4	

50 Hz					60 Hz					Selection							
Output Speed (RPM)	Output Torque		Service Factor ^[1]		Solid Shaft Overhung Load		Output Speed (RPM)	Output Torque		Service Factor ^[1]		Solid Shaft Overhung Load		Base			VFD ^[2]
	in-lbs	(N·m)	SF	AGMA Class	lbs	(N)		in-lbs	(N·m)	SF	AGMA Class	lbs	(N)	Motor Power Code	Frame Size	Ratio	
5.31	228000	(25800)	*	-	44800	(199000)	6.41	220000	(24800)	1.04	I	42300	(188000)	25	6245DA	273	C.F.
	265000	(29900)	1.04	I	54600	(243000)		1.25	I	51800	(230000)	25	6255DA	273			
			1.54	II	62000	(276000)		1.85	III	62000	(276000)	25	6265DA	273			
4.55	228000	(25800)	*	-	46800	(208000)	5.49	228000	(25800)	*	-	44200	(196000)	25	6245DA	319	C.F.
	287000	(32500)	*	-	57400	(255000)		1.12	I	54400	(242000)	25	6255DA	319			
	310000	(35000)	1.31	II	62000	(276000)		1.59	II	62000	(276000)	25	6265DA	319	C.F.		
			1.95	III	55700	(248000)		2.35	III	55700	(248000)	25	6275DA	319	C.F.		
3.85	287000	(32500)	*	-	58000	(258000)	4.64	287000	(32500)	*	-	57100	(254000)	25	6255DA	377	C.F.
	366000	(41300)	1.11	I	62000	(276000)		1.34	II	62000	(276000)	25	6265DA	377			
			1.65	III	55700	(248000)		1.99	III	55700	(248000)	25	6275DA	377			
3.07	407000	(46000)	*	-	62000	(276000)	3.70	380000	(43000)	1.07	I	62000	(276000)	25	6265DA	473	C.F.
	459000	(51900)	1.31	II	55700	(248000)		1.59	II	55700	(248000)	25	6275DA	473	C.F.		
2.59	543000	(61300)	1.11	I	55700	(248000)	3.13	450000	(50800)	1.34	II	55700	(248000)	25	6275DA	559	C.F.
2.23	630000	(71200)	0.96	-	55700	(248000)	2.70	522000	(59000)	1.16	I	55700	(248000)	25	6275DA	649	C.F.
1.98	604000	(68200)	*	-	55700	(248000)	2.39	588000	(66400)	1.03	I	55700	(248000)	25	6275DA	731	C.F.
1.72	604000	(68200)	*	-	55700	(248000)	2.08	604000	(68200)	*	-	55700	(248000)	25	6275DA	841	

Selection Tables

30 HP
22 kW

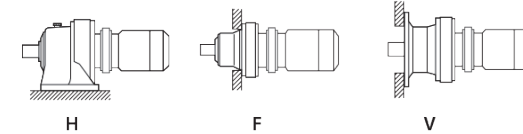

Dimension Pages:
Foot Mount (H) 2.100 - 2.129
V-Flange Mount (V) 2.130 - 2.159
F-Flange Mount (F) 2.160 - 2.189

Frequency	50 Hz	60 Hz
Input Speed	1450 RPM	1750 RPM
Number of Poles	4	

50 Hz					60 Hz					Selection								
Output Speed (RPM)	Output Torque		Service Factor ^[1]		Solid Shaft Overhung Load		Output Speed (RPM)	Output Torque		Service Factor ^[1]		Solid Shaft Overhung Load		Base			VFD ^[2]	
	in-lbs	(N·m)	SF	AGMA Class	lbs	(N)		in-lbs	(N·m)	SF	AGMA Class	lbs	(N)	Motor Power Code	Frame Size	Ratio		
483	3650	(413)	1.06	I	1780	(7930)	583	3030	(342)	1.10	I	1690	(7510)	30	6165	3		
			1.25	I	2020	(8970)		1.25	I	1910	(8490)	30	6170	3				
			1.37	I	2020	(8970)		1.37	I	1910	(8490)	30	6175	3				
290	6090	(688)	1.06	I	2110	(9400)	350	5050	(570)	1.10	I	2000	(8900)	30	6165	5		
			1.25	I	2390	(10600)		1.25	I	2260	(10100)	30	6170	5				
			1.37	I	2390	(10600)		1.37	I	2260	(10100)	30	6175	5				
242	7310	(826)	1.09	I	2260	(10100)	292	6060	(684)	1.09	I	2140	(9510)	30	6165	6		
			1.25	I	2570	(11500)		1.25	I	2430	(10800)	30	6170	6				
			1.37	II	2570	(11500)		1.37	II	2430	(10800)	30	6175	6				
181	9750	(1100)	1.09	I	2510	(11200)	219	8080	(912)	1.09	I	2380	(10600)	30	6165	8		
			1.25	I	2840	(12600)		1.25	I	2680	(11900)	30	6170	8				
			1.37	II	2840	(12600)		1.37	II	2680	(11900)	30	6175	8				
132	13400	(1510)	1.09	I	2830	(12600)	159	11100	(1250)	1.09	I	2680	(11900)	30	6165	11		
			1.25	I	3250	(14500)				1.25	I	3070	(13700)	30	6170	11		
			1.37	II	3250	(14500)				1.37	II	3070	(13700)	30	6175	11		
			1.60	III	4370	(19500)				1.60	III	4120	(18300)	30	6180	11		
			1.77	III	4370	(19500)				1.77	III	4120	(18300)	30	6185	11		
			1.86	III	6140	(27300)				1.86	III	5780	(25700)	30	6190	11		C.F.
			2.19	III	6140	(27300)				2.19	III	5780	(25700)	30	6195	11		C.F.
2.71	III	11800	(52300)	2.71	III	11100	(49500)	30	6205	11	C.F.							
112	15800	(1790)	1.03	I	2940	(13100)	135	13100	(1480)	1.03	I	2800	(12400)	30	6165	13		
			1.24	I	3370	(15000)				1.24	I	3190	(14200)	30	6170	13		
			1.37	II	3370	(15000)				1.37	II	3190	(14200)	30	6175	13		
			1.60	III	4540	(20200)				1.60	III	4280	(19100)	30	6180	13		
			1.77	III	4540	(20200)				1.77	III	4280	(19100)	30	6185	13		
			1.86	III	6380	(28400)				1.86	III	6010	(26700)	30	6190	13		C.F.
			2.19	III	6380	(28400)				2.19	III	6010	(26700)	30	6195	13		C.F.
96.7	18300	(2060)	1.02	I	3100	(13800)	117	15100	(1710)	1.03	I	2940	(13100)	30	6165	15		
			1.16	I	3510	(15600)				1.16	I	3330	(14800)	30	6170	15		
			1.37	II	3510	(15600)				1.37	II	3330	(14800)	30	6175	15		
			1.47	II	4780	(21300)				1.47	II	4510	(20100)	30	6180	15		
			1.77	III	4780	(21300)				1.77	III	4510	(20100)	30	6185	15		
			1.86	III	6700	(29800)				1.86	III	6310	(28100)	30	6190	15		C.F.
			2.19	III	6700	(29800)				2.19	III	6310	(28100)	30	6195	15		C.F.
			2.71	III	12600	(56200)				2.71	III	12000	(53200)	30	6205	15		C.F.

Notes: All 1HP+ motors require EP suffix and can be used with a VFD, unless noted per column VFD [2].

[1] Selections with service factor marked with an asterisk (*) should be limited to the identified output torque.

[2] Variable Frequency Drive Availability:

AV = AF-motor (AV suffix) option available (does not apply to EP motors [1HP+])

C.F. = Consult Factory, VFD operation needs to be reviewed.

Notes: All 1HP+ motors require EP suffix and can be used with a VFD, unless noted per column VFD [2].

[1] Selections with service factor marked with an asterisk (*) should be limited to the identified output torque.

[2] Variable Frequency Drive Availability:

AV = AF-motor (AV suffix) option available (does not apply to EP motors [1HP+])

C.F. = Consult Factory, VFD operation needs to be reviewed.

Selection Tables

**30 HP
22 kW**

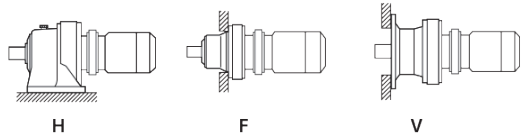

Dimension Pages:
 Foot Mount (H) 2.100 - 2.129
 V-Flange Mount (V) 2.130 - 2.159
 F-Flange Mount (F) 2.160 - 2.189

Frequency	50 Hz	60 Hz
Input Speed	1450 RPM	1750 RPM
Number of Poles	4	

50 Hz					60 Hz					Selection							
Output Speed (RPM)	Output Torque		Service Factor ^[1]		Solid Shaft Overhung Load		Output Speed (RPM)	Output Torque		Service Factor ^[1]		Solid Shaft Overhung Load		Base			VFD ^[2]
	in-lbs	(N·m)	SF	AGMA Class	lbs	(N)		in-lbs	(N·m)	SF	AGMA Class	lbs	(N)	Motor Power Code	Frame Size	Ratio	
85.3	20700	(2340)	0.86	-	3170	(14100)	103	17200	(1940)	0.86	-	3020	(13400)	30	6165	17	
			0.89	-	3650	(16200)				0.89	-	3460	(15400)	30	6170	17	
			1.09	I	3650	(16200)				1.09	I	3460	(15400)	30	6175	17	
			1.39	II	5040	(22400)				1.39	II	4760	(21200)	30	6180	17	
			1.74	III	5040	(22400)				1.77	III	4760	(21200)	30	6185	17	
			1.86	III	7060	(31400)				1.86	III	6650	(29600)	30	6190	17	C.F.
			2.19	III	7060	(31400)				2.19	III	6650	(29600)	30	6195	17	C.F.
69.0	25600	(2890)	1.07	I	3920	(17500)	83.3	21200	(2400)	1.09	I	3720	(16600)	30	6175	21	
			1.36	II	5400	(24000)				1.36	II	5100	(22700)	30	6180	21	
			1.73	III	5400	(24000)				1.77	III	5100	(22700)	30	6185	21	
			1.86	III	7590	(33700)				1.86	III	7150	(31800)	30	6190	21	
			2.19	III	7590	(33700)				2.19	III	7150	(31800)	30	6195	21	
			2.69	III	14100	(62900)				2.69	III	13400	(59500)	30	6205	21	C.F.
58.0	30500	(3440)	0.89	-	4030	(17900)	70.0	25200	(2850)	0.89	-	3830	(17000)	30	6175	25	
			1.09	I	5590	(24900)				1.09	I	5280	(23500)	30	6180	25	
			1.37	II	5590	(24900)				1.37	II	5280	(23500)	30	6185	25	
			1.60	III	7930	(35300)				1.60	III	7470	(33200)	30	6190	25	
			1.84	III	7930	(35300)				1.84	III	7470	(33200)	30	6195	25	
			2.66	III	15700	(70000)				2.66	III	14900	(66200)	30	6215	29	C.F.
50.0	35300	(3990)	1.09	I	5820	(25900)	60.3	29300	(3310)	1.09	I	5510	(24500)	30	6185	29	
			1.40	II	8320	(37000)				1.40	II	7840	(34900)	30	6190	29	
			1.72	III	8320	(37000)				1.72	III	7840	(34900)	30	6195	29	
			2.08	III	15400	(68500)				2.08	III	14600	(64900)	30	6205	29	C.F.
			2.66	III	15700	(70000)				2.66	III	14900	(66200)	30	6215	29	C.F.
41.4	42600	(4820)	1.03	I	6190	(27500)	50.0	35300	(3990)	1.03	I	5850	(26000)	30	6185	35	
			1.10	I	8760	(39000)				1.10	I	8260	(36700)	30	6190	35	
			1.37	II	8760	(39000)				1.37	II	8260	(36700)	30	6195	35	
33.7	52400	(5920)	0.84	-	6540	(29100)	40.7	43400	(4900)	0.86	-	6210	(27600)	30	6185	43	
			0.95	-	9390	(41800)				0.95	-	8860	(39400)	30	6190	43	
			1.23	I	9390	(41800)				1.37	II	8860	(39400)	30	6195	43	
			1.45	II	17300	(77100)				1.45	II	16400	(73000)	30	6205	43	C.F.
			2.05	III	17700	(78700)				2.05	III	16800	(74600)	30	6215	43	C.F.
			2.57	III	18800	(83400)				2.57	III	17800	(79000)	30	6225	43	C.F.
28.4	62100	(7020)	0.95	-	9750	(43400)	34.3	51500	(5820)	0.95	-	9210	(41000)	30	6195	51	
24.6	71900	(8120)	0.86	-	10200	(45300)	29.7	59600	(6730)	0.86	-	9630	(42800)	30	6195	59	
			1.03	I	18800	(83600)				1.03	I	17800	(79200)	30	6205	59	
			1.54	II	19200	(85300)				1.71	III	18200	(80800)	30	6215	59	C.F.
			1.79	III	20300	(90500)				2.05	III	19300	(85700)	30	6225	59	C.F.
16.7	106000	(12000)	1.22	I	22700	(101000)	20.1	87800	(9920)	1.22	I	21500	(95700)	30	6225	87	

Notes: All 1HP+ motors require EP suffix and can be used with a VFD, unless noted per column VFD [2].

[1] Selections with service factor marked with an asterisk (*) should be limited to the identified output torque.

[2] Variable Frequency Drive Availability:

AV = AF-motor (AV suffix) option available (does not apply to EP motors [1HP+])

C.F. = Consult Factory, VFD operation needs to be reviewed.

Selection Tables

**30 HP
22 kW**

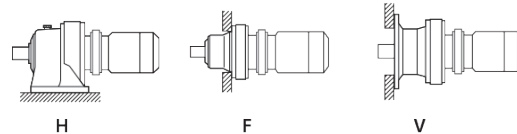

Dimension Pages:
 Foot Mount (H) 2.100 - 2.129
 V-Flange Mount (V) 2.130 - 2.159
 F-Flange Mount (F) 2.160 - 2.189

Frequency	50 Hz	60 Hz
Input Speed	1450 RPM	1750 RPM
Number of Poles	4	

50 Hz					60 Hz					Selection							
Output Speed (RPM)	Output Torque		Service Factor ^[1]		Solid Shaft Overhung Load		Output Speed (RPM)	Output Torque		Service Factor ^[1]		Solid Shaft Overhung Load		Base			VFD ^[2]
	in-lbs	(N·m)	SF	AGMA Class	lbs	(N)		in-lbs	(N·m)	SF	AGMA Class	lbs	(N)	Motor Power Code	Frame Size	Ratio	
12.0	101000	(11400)	*	-	23400	(104000)	14.5	101000	(11400)	*	-	22600	(101000)	30	6215DB	121	
			*	-	25400	(113000)				1.03	I	23900	(106000)	30	6225DB	121	
			1.09	I	31800	(141000)				1.09	I	30100	(134000)	30	6235DA	121	
			1.19	I	31800	(141000)				1.43	II	30100	(134000)	30	6235DB	121	
			1.30	II	35400	(157000)				1.57	II	33500	(149000)	30	6245DB	121	
			1.74	III	43500	(193000)				2.10	III	41200	(183000)	30	6255DB	121	C.F.
			1.99	III	53200	(237000)				2.19	III	50300	(224000)	30	6265DA	121	C.F.
8.79	174000	(19600)	*	-	34000	(151000)	10.6	158000	(17800)	1.09	I	32200	(143000)	30	6235DA	165	
			1.09	I	37900	(169000)				1.09	I	36000	(160000)	30	6245DA	165	
			1.22	I	37900	(169000)				1.47	II	36000	(160000)	30	6245DB	165	
			1.45	II	46600	(207000)				1.75	III	44200	(196000)	30	6255DB	165	C.F.
			2.03	III	57000	(253000)				2.19	III	53900	(240000)	30	6265DA	165	C.F.
7.44	174000	(19600)	*	-	35800	(159000)	8.97	174000	(19600)	*	-	33800	(150000)	30	6235DA	195	
			1.03	I	39800	(177000)				1.03	I	37700	(168000)	30	6245DA	195	
			1.03	I	39800	(177000)				1.25	I	37700	(168000)	30	6245DB	195	
			1.23	I	48900	(218000)				1.37	II	46300	(206000)	30	6255DA	195	
			1.23	I	48900	(218000)				1.48	II	46300	(206000)	30	6255DB	195	C.F.
			1.72	III	59800	(266000)				2.08	III	56600	(252000)	30	6265DA	195	C.F.
6.28	228000	(25800)	*	-	42500	(189000)	7.58	221000	(25000)	1.03	I	40200	(179000)	30	6245DA	231	
			1.03	I	51900	(231000)				1.24	I	49200	(219000)	30	6255DA	231	
			1.53	II	62000	(276000)				1.84	III	60300	(268000)	30	6265DA	231	C.F.
5.31	228000	(25800)	*	-	44800	(199000)	6.41	228000	(25800)	*	-	42300	(188000)	30	6245DA	273	
			*	-	54600	(243000)				1.05	I	51600	(229000)	30	6255DA	273	
			1.29	I	62000	(276000)				1.56	II	62000	(276000)	30	6265DA	273	C.F.
4.55	287000	(32500)	*	-	57400	(255000)	5.49	287000	(32500)	*	-	54200	(241000)	30	6255DA	319	
			1.11	I	62000	(276000)				1.33	II	62000	(276000)	30	6265DA	319	C.F.
3.85	407000	(46000)	*	-	62000	(276000)	4.64	361000	(40700)	1.13	I	62000	(276000)	30	6265DA	377	C.F.
3.07	407000	(46000)	1.39	II	55700	(248000)	3.70	407000	(46000)	1.67	III	55700	(248000)	30	6275DA	377	C.F.
2.59	604000	(68200)	*	-	55700	(248000)	3.13	535000	(60400)	1.13	I	55700	(248000)	30	6275DA	559	C.F.
2.23	604000	(68200)	1.11	I	55700	(248000)	2.70	621000	(70100)	1.33	II	55700	(248000)	30	6275DA	649	C.F.
1.98	604000	(68200)	*	-	55700	(248000)	2.39	604000	(68200)	0.97	-	55700	(248000)	30	6275DA	731	C.F.

Notes: All 1HP+ motors require EP suffix and can be used with a VFD, unless noted per column VFD [2].

[1] Selections with service factor marked with an asterisk (*) should be limited to the identified output torque.

[2] Variable Frequency Drive Availability:

AV = AF-motor (AV suffix) option available (does not apply to EP motors [1HP+])

C.F. = Consult Factory, VFD operation needs to be reviewed.

Selection Tables

40 HP
30 kW

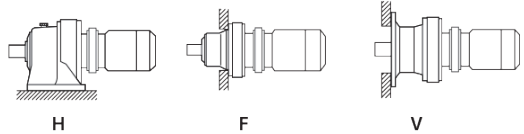

Dimension Pages:
Foot Mount (H) 2.100 - 2.129
V-Flange Mount (V) 2.130 - 2.159
F-Flange Mount (F) 2.160 - 2.189

Frequency	50 Hz	60 Hz
Input Speed	1450 RPM	1750 RPM
Number of Poles	4	

50 Hz					60 Hz					Selection							
Output Speed (RPM)	Output Torque		Service Factor ^[1]		Solid Shaft Overhung Load		Output Speed (RPM)	Output Torque		Service Factor ^[1]		Solid Shaft Overhung Load		Base			VFD ^[2]
	in-lbs	(N·m)	SF	AGMA Class	lbs	(N)		in-lbs	(N·m)	SF	AGMA Class	lbs	(N)	Motor Power Code	Frame Size	Ratio	
483	4980	(563)	1.00	I	2020	(8970)	583	4130	(467)	1.00	I	1910	(8490)	40	6175	3	
290	8310	(939)	1.00	I	2390	(10600)	350	6880	(778)	1.00	I	2260	(10100)	40	6175	5	
242	9970	(1130)	1.00	I	2530	(11300)	292	8260	(933)	1.00	I	2400	(10700)	40	6175	6	
181	13300	(1500)	1.00	I	2780	(12400)	219	11000	(1240)	1.00	I	2640	(11700)	40	6175	8	
132	18300	(2060)	1.00	I	3170	(14100)	159	15100	(1710)	1.00	I	3010	(13400)	40	6175	11	
			1.17	I	4320	(19200)				1.17	I	4080	(18200)	40	6180	11	
			1.30	II	4320	(19200)				1.30	II	4080	(18200)	40	6185	11	
			1.37	II	6100	(27100)				1.37	II	5740	(25500)	40	6190	11	C.F.
			1.60	III	6100	(27100)				1.60	III	5740	(25500)	40	6195	11	C.F.
			1.99	III	11700	(52200)				1.99	III	11100	(49400)	40	6205	11	C.F.
2.51	III	11900	(52900)	2.51	III	11200	(50000)	40	6215	11	C.F.						
112	21600	(2440)	1.00	I	3280	(14600)	135	17900	(2020)	1.00	I	3120	(13900)	40	6175	13	
			1.17	I	4480	(19900)				1.17	I	4230	(18800)	40	6180	13	
			1.30	II	4480	(19900)				1.30	II	4230	(18800)	40	6185	13	
			1.37	II	6330	(28200)				1.37	II	5970	(26500)	40	6190	13	
			1.60	III	6330	(28200)				1.60	III	5970	(26500)	40	6195	13	
			96.7	24900	(2820)	1.00				I	3390	(15100)	117	20600	(2330)	1.00	I
			1.08	I	4700	(20900)	1.08	I	4450	(19800)	40	6180	15				
			1.30	II	4700	(20900)	1.30	II	4450	(19800)	40	6185	15				
			1.37	II	6640	(29500)	1.37	II	6260	(27800)	40	6190	15				
			1.60	III	6640	(29500)	1.60	III	6260	(27800)	40	6195	15				
			1.99	III	12600	(56000)	1.99	III	11900	(53000)	40	6205	15	C.F.			
			2.51	III	12800	(56800)	2.51	III	12100	(53800)	40	6215	15	C.F.			
85.3	28200	(3190)	1.02	I	4950	(22000)	103	23400	(2640)	1.02	I	4680	(20800)	40	6180	17	
			1.27	I	4950	(22000)				1.30	II	4680	(20800)	40	6185	17	
			1.37	II	6990	(31100)				1.37	II	6600	(29300)	40	6190	17	
			1.60	III	6990	(31100)				1.60	III	6600	(29300)	40	6195	17	
			69.0	34900	(3940)	1.00				I	5310	(23600)	83.3	28900	(3270)	1.00	I
			1.27	I	5310	(23600)	1.30	II	5030	(22400)	40	6185	21				
			1.37	II	7520	(33500)	1.37	II	7090	(31500)	40	6190	21				
			1.60	III	7520	(33500)	1.60	III	7090	(31500)	40	6195	21				
			1.97	III	14100	(62700)	1.97	III	13300	(59300)	40	6205	21	C.F.			
			2.51	III	14400	(64100)	2.51	III	13600	(60700)	40	6215	21	C.F.			
			58.0	41500	(4690)	1.00	I	5480	(24400)	70.0	34400	(3890)	1.00	I	5190	(23100)	40
1.17	I	7850				(34900)	1.17	I	7410				(32900)	40	6190	25	
1.35	II	7850				(34900)	1.35	II	7410				(32900)	40	6195	25	

Selection Tables

40 HP
30 kW

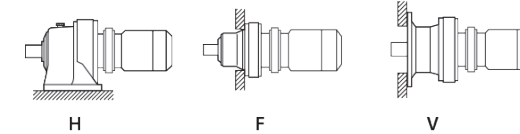

Dimension Pages:
Foot Mount (H) 2.100 - 2.129
V-Flange Mount (V) 2.130 - 2.159
F-Flange Mount (F) 2.160 - 2.189

Frequency	50 Hz	60 Hz
Input Speed	1450 RPM	1750 RPM
Number of Poles	4	

50 Hz					60 Hz					Selection							
Output Speed (RPM)	Output Torque		Service Factor ^[1]		Solid Shaft Overhung Load		Output Speed (RPM)	Output Torque		Service Factor ^[1]		Solid Shaft Overhung Load		Base			VFD ^[2]
	in-lbs	(N·m)	SF	AGMA Class	lbs	(N)		in-lbs	(N·m)	SF	AGMA Class	lbs	(N)	Motor Power Code	Frame Size	Ratio	
50.0	48200	(5440)	0.80	-	5690	(25300)	60.3	39900	(4510)	0.80	-	5400	(24000)	40	6185	29	
			1.02	I	8220	(36600)				1.02	I	7760	(34500)	40	6190	29	
			1.26	I	8220	(36600)				1.26	I	7760	(34500)	40	6195	29	
			1.52	II	15300	(68200)				1.52	II	14500	(64600)	40	6205	29	C.F.
			1.95	III	15600	(69600)				1.95	III	14800	(65900)	40	6215	29	C.F.
			2.51	III	16600	(73700)				2.51	III	15700	(69800)	40	6225	29	C.F.
41.4	58100	(6570)	1.00	I	8640	(38400)	50.0	48200	(5440)	1.00	I	8170	(36300)	40	6195	35	
33.7	71400	(8070)	0.90	-	9250	(41100)	40.7	59200	(6690)	1.00	I	8740	(38900)	40	6195	43	
			1.06	I	17200	(76600)				1.06	I	16300	(72600)	40	6205	43	
			1.51	II	17600	(78200)				1.51	II	16700	(74100)	40	6215	43	C.F.
			1.88	III	18600	(83000)				1.88	III	17700	(78600)	40	6225	43	C.F.
24.6	98000	(11100)	1.13	I	19000	(84600)	29.7	81200	(9180)	1.26	I	18000	(80300)	40	6215	59	
			1.31	II	20200	(89800)				1.51	II	19100	(85200)	40	6225	59	C.F.
12.0	119000	(13500)	*	-	25400	(113000)	14.5	119000	(13500)	*	-	23900	(106000)	40	6225DB	121	
			*	-	31600	(141000)				1.05	I	29900	(133000)	40	6235DB	121	
			*	-	35200	(156000)				1.15	I	33300	(148000)	40	6245DB	121	
			1.28	I	43200	(192000)				1.54	II	40900	(182000)	40	6255DB	121	C.F.
			1.46	II	53000	(236000)				1.60	III	50200	(223000)	40	6265DA	121	C.F.
8.79	174000	(19600)	*	-	34000	(151000)	10.6	174000	(19600)	*	-	32100	(143000)	40	6235DB	165	
			*	-	37700	(168000)				1.08	I	35700	(159000)	40	6245DB	165	
			1.06	I	46300	(206000)				1.28	I	43900	(195000)	40	6255DB	165	C.F.
			1.49	II	56700	(252000)				1.60	III	53700	(239000)	40	6265DA	165	C.F.
7.44	232000	(26200)	*	-	39700	(177000)	8.97	232000	(26200)	*	-	37500	(167000)	40	6245DB	195	
			*	-	48700	(216000)				1.00	I	46000	(205000)	40	6255DA	195	C.F.
			*	-	48700	(216000)				1.08	I	46000	(205000)	40	6255DB	195	
			1.26	I	59500	(265000)				1.52	II	56300	(251000)	40	6265DA	195	
6.28	228000	(25800)	*	-	42500	(189000)	7.58	228000	(25800)	*	-	40100	(179000)	40	6245DB	231	
			*	-	51800	(231000)				1.00	I	48900	(218000)	40	6255DA	231	
			1.12	I	62000	(276000)				1.35	II	60000	(267000)	40	6265DA	231	C.F.
5.31	274000	(31000)	*	-	54600	(243000)	6.41	274000	(31000)	*	-	51500	(229000)	40	6255DA	273	
			*	-	62000	(276000)				1.14	I	62000	(276000)	40	6265DA	273	
4.55	407000	(46000)	*	-	62000	(276000)	5.49	416000	(47000)	0.98	-	62000	(276000)	40	6265DA	319	C.F.
			1.20	I	55700	(248000)				1.45	II	55700	(248000)	40	6275DA	319	C.F.
3.85	407000	(46000)	*	-	62000	(276000)	4.64	407000	(46000)	*	-	62000	(276000)	40	6265DA	377	
			1.02	I	55700	(248000)				1.23	I	55700	(248000)	40	6275DA	377	
3.07	604000	(68200)	*	-	55700	(248000)	3.70	617000	(69700)	0.98	-	55700	(248000)	40	6275DA	473	C.F.
2.59	604000	(68200)	*	-	55700	(248000)	3.13	604000	(68200)	*	-	55700	(248000)	40	6275DA	559	

Notes: All 1HP+ motors require EP suffix and can be used with a VFD, unless noted per column VFD [2].
[1] Selections with service factor marked with an asterisk (*) should be limited to the identified output torque.
[2] Variable Frequency Drive Availability:
AV = AF-motor (AV suffix) option available (does not apply to EP motors [1HP+])
C.F. = Consult Factory, VFD operation needs to be reviewed.

Notes: All 1HP+ motors require EP suffix and can be used with a VFD, unless noted per column VFD [2].
[1] Selections with service factor marked with an asterisk (*) should be limited to the identified output torque.
[2] Variable Frequency Drive Availability:
AV = AF-motor (AV suffix) option available (does not apply to EP motors [1HP+])
C.F. = Consult Factory, VFD operation needs to be reviewed.

Selection Tables

50 HP
37 kW

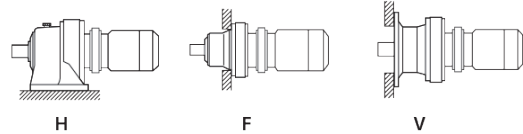

Dimension Pages:
Foot Mount (H) 2.100 - 2.129
V-Flange Mount (V) 2.130 - 2.159
F-Flange Mount (F) 2.160 - 2.189

Frequency	50 Hz	60 Hz
Input Speed	1450 RPM	1750 RPM
Number of Poles	4	

50 Hz					60 Hz					Selection							
Output Speed (RPM)	Output Torque		Service Factor ^[1]		Solid Shaft Overhung Load		Output Speed (RPM)	Output Torque		Service Factor ^[1]		Solid Shaft Overhung Load		Base			VFD ^[2]
	in-lbs	(N·m)	SF	AGMA Class	lbs	(N)		in-lbs	(N·m)	SF	AGMA Class	lbs	(N)	Motor Power Code	Frame Size	Ratio	
132	22500	(2550)	1.05	I	4280	(19000)	159	18700	(2110)	1.05	I	4040	(18000)	50	6185	11	C.F.
			1.11	I	6060	(27000)				1.11	I	5710	(25400)	50	6190	11	
			1.30	II	6060	(27000)				1.30	II	5710	(25400)	50	6195	11	
			1.61	III	11700	(52000)				1.61	III	11100	(49300)	50	6205	11	
			2.04	III	11900	(52700)				2.04	III	11200	(49900)	50	6215	11	
			2.69	III	12600	(56000)				2.69	III	11900	(53000)	50	6225	11	
112	26600	(3010)	1.05	I	4430	(19700)	135	22100	(2490)	1.05	I	4190	(18600)	50	6185	13	C.F.
			1.11	I	6290	(28000)				1.11	I	5930	(26400)	50	6190	13	
			1.30	II	6290	(28000)				1.30	II	5930	(26400)	50	6195	13	
96.7	30700	(3470)	1.05	I	4630	(20600)	117	25500	(2880)	1.05	I	4390	(19500)	50	6185	15	C.F.
			1.11	I	6590	(29300)				1.11	I	6220	(27700)	50	6190	15	
			1.30	II	6590	(29300)				1.30	II	6220	(27700)	50	6195	15	
			1.61	III	12600	(55900)				1.61	III	11900	(52900)	50	6205	15	
			2.04	III	12700	(56600)				2.04	III	12100	(53600)	50	6215	15	
			2.69	III	13600	(60400)				2.69	III	12900	(57200)	50	6225	15	
85.3	34800	(3940)	1.03	I	4870	(21600)	103	28900	(3260)	1.05	I	4620	(20500)	50	6185	17	C.F.
			1.11	I	6940	(30900)				1.11	I	6550	(29100)	50	6190	17	
			1.30	II	6940	(30900)				1.30	II	6550	(29100)	50	6195	17	
69.0	43000	(4860)	1.03	I	5230	(23300)	83.3	35700	(4030)	1.05	I	4960	(22100)	50	6185	21	C.F.
			1.11	I	7460	(33200)				1.11	I	7040	(31300)	50	6190	21	
			1.30	II	7460	(33200)				1.30	II	7040	(31300)	50	6195	21	
			1.60	III	14000	(62500)				1.60	III	13300	(59200)	50	6205	21	
			2.04	III	14400	(63800)				2.04	III	13600	(60500)	50	6215	21	
			2.55	III	15200	(67500)				2.55	III	14400	(63900)	50	6225	21	
58.0	51200	(5790)	0.81	-	5380	(23900)	70.0	42400	(4800)	0.81	-	5110	(22700)	50	6185	25	C.F.
			0.95	-	7780	(34600)				0.95	-	7350	(32700)	50	6190	25	
			1.09	I	7780	(34600)				1.09	I	7350	(32700)	50	6195	25	
50.0	59400	(6710)	1.02	I	8140	(36200)	60.3	49200	(5560)	1.02	I	7690	(34200)	50	6195	29	C.F.
			1.23	I	15300	(67900)				1.23	I	14500	(64400)	50	6205	29	
			1.58	II	15600	(69300)				1.58	II	14800	(65700)	50	6215	29	
			2.04	III	16500	(73400)				2.04	III	15600	(69600)	50	6225	29	
41.4	71700	(8100)	0.81	-	8540	(38000)	50.0	59400	(6710)	0.81	-	8080	(35900)	50	6195	35	C.F.
33.7	88100	(9950)	1.22	I	17500	(77700)	40.7	73000	(8250)	1.22	I	16600	(73800)	50	6215	43	C.F.
			1.53	II	18600	(82500)				1.53	II	17600	(78300)	50	6225	43	
24.6	121000	(13700)	1.06	I	20000	(89200)	29.7	100000	(11300)	1.22	I	19000	(84700)	50	6225	59	C.F.
12.0	166000	(18700)	*	-	31600	(141000)	14.5	166000	(18700)	*	-	29800	(133000)	50	6235DB	121	C.F.
			*	-	35200	(156000)				*	-	33200	(148000)	50	6245DB	121	
			1.04	I	43000	(191000)				1.25	I	40700	(181000)	50	6255DB	121	
			1.18	I	52800	(235000)				1.30	II	50000	(222000)	50	6265DA	121	

Notes: All 1HP+ motors require EP suffix and can be used with a VFD, unless noted per column VFD [2].

[1] Selections with service factor marked with an asterisk (*) should be limited to the identified output torque.

[2] Variable Frequency Drive Availability:

AV = AF-motor (AV suffix) option available (does not apply to EP motors [1HP+])

C.F. = Consult Factory, VFD operation needs to be reviewed.

Selection Tables

50 HP
37 kW

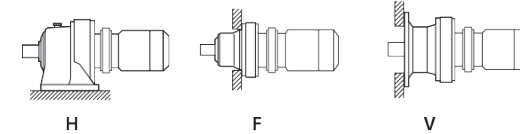

Dimension Pages:
Foot Mount (H) 2.100 - 2.129
V-Flange Mount (V) 2.130 - 2.159
F-Flange Mount (F) 2.160 - 2.189

Frequency	50 Hz	60 Hz
Input Speed	1450 RPM	1750 RPM
Number of Poles	4	

50 Hz					60 Hz					Selection							
Output Speed (RPM)	Output Torque		Service Factor ^[1]		Solid Shaft Overhung Load		Output Speed (RPM)	Output Torque		Service Factor ^[1]		Solid Shaft Overhung Load		Base			VFD ^[2]
	in-lbs	(N·m)	SF	AGMA Class	lbs	(N)		in-lbs	(N·m)	SF	AGMA Class	lbs	(N)	Motor Power Code	Frame Size	Ratio	
8.79	232000	(26200)	*	-	37700	(168000)	10.6	232000	(26200)	*	-	35600	(158000)	50	6245DB	165	C.F.
			*	-	46200	(206000)				1.04	I	43700	(194000)	50	6255DB	165	
			1.21	I	56500	(251000)				1.30	II	53500	(238000)	50	6265DA	165	
7.44	276000	(31200)	*	-	48700	(216000)	8.97	276000	(31200)	*	-	45900	(204000)	50	6255DB	195	C.F.
			1.02	I	59200	(263000)				1.23	I	56100	(250000)	50	6265DA	195	
6.28	407000	(46000)	*	-	62000	(276000)	7.58	372000	(42000)	1.10	I	59700	(266000)	50	6265DA	231	C.F.
5.31	407000	(46000)	*	-	62000	(276000)	6.41	407000	(46000)	*	-	62000	(276000)	50	6265DA	273	C.F.
4.55	619000	(70000)	0.97	-	55700	(248000)	5.49	513000	(58000)	1.18	I	55700	(248000)	50	6275DA	319	C.F.
3.85	604000	(68200)	*	-	55700	(248000)	4.64	606000	(68500)	1.00	I	55700	(248000)	50	6275DA	377	C.F.

Notes: All 1HP+ motors require EP suffix and can be used with a VFD, unless noted per column VFD [2].

[1] Selections with service factor marked with an asterisk (*) should be limited to the identified output torque.

[2] Variable Frequency Drive Availability:

AV = AF-motor (AV suffix) option available (does not apply to EP motors [1HP+])

C.F. = Consult Factory, VFD operation needs to be reviewed.

Selection Tables

60 HP
45 kW

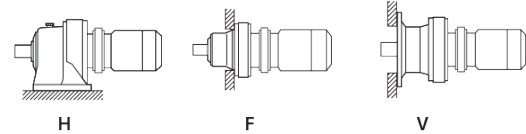

Dimension Pages:
Foot Mount (H) 2.100 - 2.129
V-Flange Mount (V) 2.130 - 2.159
F-Flange Mount (F) 2.160 - 2.189

Frequency	50 Hz	60 Hz
Input Speed	1450 RPM	1750 RPM
Number of Poles	4	

50 Hz					60 Hz					Selection							
Output Speed (RPM)	Output Torque		Service Factor ^[1]		Solid Shaft Overhung Load		Output Speed (RPM)	Output Torque		Service Factor ^[1]		Solid Shaft Overhung Load		Base			VFD ^[2]
	in-lbs	(N·m)	SF	AGMA Class	lbs	(N)		in-lbs	(N·m)	SF	AGMA Class	lbs	(N)	Motor Power Code	Frame Size	Ratio	
132	27400	(3100)	1.07	I	6020	(26800)	159	22700	(2570)	1.07	I	5680	(25300)	60	6195	11	C.F.
			1.33	II	11700	(51900)				1.33	II	11000	(49200)	60	6205	11	
			1.67	III	11800	(52600)				1.67	III	11200	(49800)	60	6215	11	
			2.21	III	12500	(55800)				2.21	III	11900	(52800)	60	6225	11	
112	32400	(3660)	1.07	I	6230	(27700)	135	26800	(3030)	1.07	I	5890	(26200)	60	6195	13	
96.7	37400	(4220)	1.07	I	6520	(29000)	117	31000	(3500)	1.07	I	6170	(27400)	60	6195	15	C.F.
			1.33	II	12500	(55700)				1.33	II	11900	(52800)	60	6205	15	
			1.67	III	12700	(56500)				1.67	III	12000	(53500)	60	6215	15	
			2.21	III	13500	(60200)				2.21	III	12800	(57000)	60	6225	15	
85.3	42400	(4790)	0.91	-	6870	(30600)	103	35100	(3970)	0.91	-	6500	(28900)	60	6190	17	
			1.07	I	6870	(30600)				1.07	I	6500	(28900)	60	6195	17	
69.0	52300	(5910)	0.91	-	7390	(32900)	83.3	43400	(4900)	0.91	-	6980	(31100)	60	6190	21	C.F.
			1.07	I	7390	(32900)				1.07	I	6980	(31100)	60	6195	21	
			1.32	II	14000	(62200)				1.32	II	13300	(59000)	60	6205	21	
			1.67	III	14300	(63600)				1.67	III	13500	(60300)	60	6215	21	
			2.09	III	15100	(67200)				2.09	III	14300	(63700)	60	6225	21	
58.0	62300	(7040)	0.90	-	7700	(34200)	70.0	51600	(5830)	0.90	-	7280	(32400)	60	6195	25	
50.0	72300	(8170)	0.84	-	8040	(35700)	60.3	59900	(6770)	0.84	-	7610	(33900)	60	6195	29	C.F.
			1.01	I	15200	(67600)				1.01	I	14400	(64100)	60	6205	29	
			1.30	II	15500	(68900)				1.30	II	14700	(65400)	60	6215	29	
			1.67	III	16400	(73100)				1.67	III	15600	(69300)	60	6225	29	
33.7	107000	(12100)	1.00	I	17400	(77200)	40.7	88800	(10000)	1.00	I	16500	(73300)	60	6215	43	C.F.
			1.26	I	18400	(82000)				1.26	I	17500	(77800)	60	6225	43	
12.0	243000	(27500)	*	-	42900	(191000)	14.5	237000	(26700)	1.03	I	40500	(180000)	60	6255DB	121	
	286000	(32300)	0.97	-	52600	(234000)				1.07	I	49800	(222000)	60	6265DA	121	
8.79	390000	(44000)	0.99	-	56200	(250000)	10.6	323000	(36500)	1.07	I	53300	(237000)	60	6265DA	165	
7.44	387000	(43700)	*	-	59200	(263000)	8.97	381000	(43100)	1.01	I	55800	(248000)	60	6265DA	195	
6.28	407000	(46000)	*	-	62000	(276000)	7.58	407000	(46000)	*	-	59600	(265000)	60	6265DA	231	
4.55	604000	(68200)	*	-	55700	(248000)	5.49	624000	(70500)	0.97	-	55700	(248000)	60	6275DA	319	

Notes: All 1HP+ motors require EP suffix and can be used with a VFD, unless noted per column VFD [2].
 [1] Selections with service factor marked with an asterisk (*) should be limited to the identified output torque.
 [2] Variable Frequency Drive Availability:
 AV = AF-motor (AV suffix) option available (does not apply to EP motors [1HP+])
 C.F. = Consult Factory, VFD operation needs to be reviewed.

Selection Tables

75 HP
55 kW

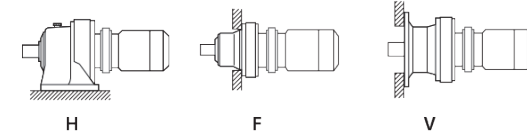

Dimension Pages:
Foot Mount (H) 2.100 - 2.129
V-Flange Mount (V) 2.130 - 2.159
F-Flange Mount (F) 2.160 - 2.189

Frequency	50 Hz	60 Hz
Input Speed	1450 RPM	1750 RPM
Number of Poles	4	

50 Hz					60 Hz					Selection							
Output Speed (RPM)	Output Torque		Service Factor ^[1]		Solid Shaft Overhung Load		Output Speed (RPM)	Output Torque		Service Factor ^[1]		Solid Shaft Overhung Load		Base			VFD ^[2]
	in-lbs	(N·m)	SF	AGMA Class	lbs	(N)		in-lbs	(N·m)	SF	AGMA Class	lbs	(N)	Motor Power Code	Frame Size	Ratio	
132	33500	(3790)	1.09	I	11600	(51700)	159	27800	(3140)	1.09	I	11000	(49000)	75	6205	11	C.F.
			1.37	II	11800	(52400)				1.37	II	11200	(49700)	75	6215	11	
			1.81	III	12500	(55600)				1.81	III	11800	(52700)	75	6225	11	
			1.09	I	12500	(55500)				1.09	I	11800	(52600)	75	6205	15	
96.7	45700	(5160)	1.37	II	12600	(56200)	117	37900	(4280)	1.37	II	12000	(53300)	75	6215	15	C.F.
			1.81	III	13500	(60000)				1.81	III	12800	(56900)	75	6225	15	
			1.08	I	13900	(61900)				1.08	I	13200	(58700)	75	6205	21	
69.0	64000	(7230)	1.37	II	14200	(63300)	83.3	53000	(5990)	1.37	II	13500	(60000)	75	6215	21	C.F.
			1.71	III	15000	(66900)				1.71	III	14300	(63400)	75	6225	21	
			1.06	I	15400	(68500)				1.06	I	14600	(65000)	75	6215	29	
50.0	88300	(9980)	1.37	II	16300	(72700)	60.3	73200	(8270)	1.37	II	15500	(69000)	75	6225	29	C.F.
			1.03	I	18300	(81400)				1.03	I	17400	(77300)	75	6225	43	
33.7	131000	(14800)	1.03	I	18300	(81400)	40.7	109000	(12300)	1.03	I	17400	(77300)	75	6225	43	C.F.

Notes: All 1HP+ motors require EP suffix and can be used with a VFD, unless noted per column VFD [2].
 [1] Selections with service factor marked with an asterisk (*) should be limited to the identified output torque.
 [2] Variable Frequency Drive Availability:
 AV = AF-motor (AV suffix) option available (does not apply to EP motors [1HP+])
 C.F. = Consult Factory, VFD operation needs to be reviewed.

Dimensions Integral Universal Foot Mount

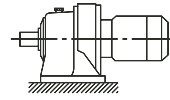

CNHM01-6065DAY ▶ CNHM1-6085Y-EP

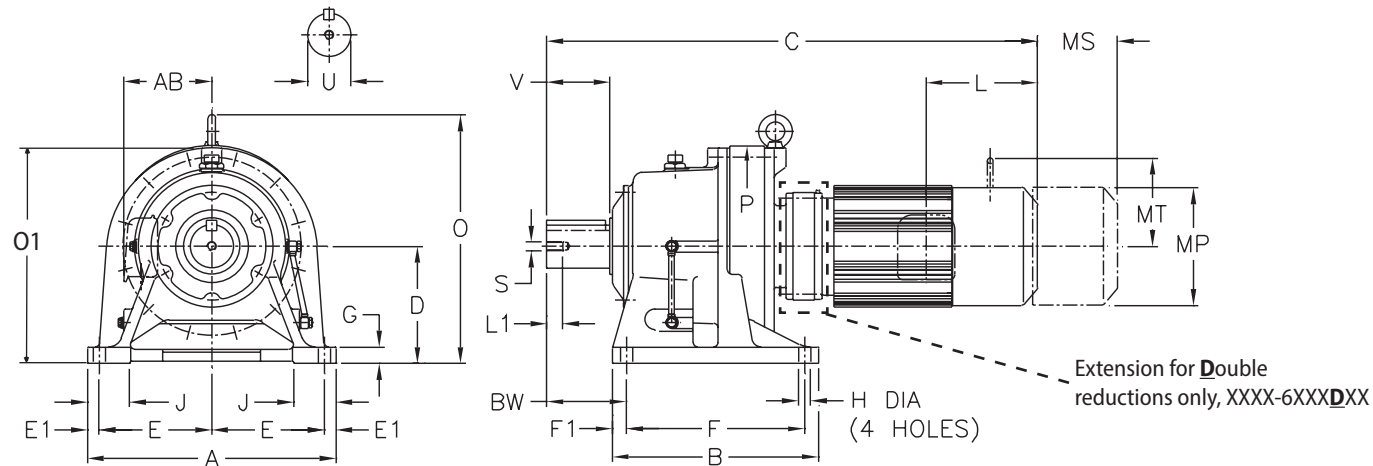

Table 1: Shaft Tolerances All dimensions are in inches (mm)

Low Speed Shaft Nominal Diameter	Tolerance
0.500 through 0.625 (12.700 through 15.875)	+0.0000 / -0.0004 (+0.000 / -0.011)
0.750 through 1.125 (19.050 through 28.757)	+0.0000 / -0.0005 (+0.000 / -0.013)
1.250 through 1.875 (31.750 through 47.625)	+0.0000 / -0.0006 (+0.000 / -0.016)
2.000 through 3.125 (50.800 through 79.375)	+0.0000 / -0.0007 (+0.000 / -0.019)
3.250 through 4.625 (82.550 through 117.475)	+0.0000 / -0.0009 (+0.000 / -0.022)
4.750 through 7.000 (120.650 through 177.800)	+0.0000 / -0.0010 (+0.000 / -0.025)

Note: CNHM units are greased life units, and can be mounted in any position. Dimensions are in inches (mm)

Model CNHM, PHHM	A	B	D	E	E1	F	F1	G	H	J	P	BW
6060Y 6065Y	5.67 (144)	3.31 (84)	3.150 (80)	2.36 (60)	0.47 (12)	2.36 (60)	0.47 (12)	0.39 (10)	0.35 (9)	1.89 (48)	4.33 (110)	1.61 (41)
6070Y 6075Y	5.67 (144)	3.31 (84)	3.150 (80)	2.36 (60)	0.47 (12)	2.36 (60)	0.47 (12)	0.39 (10)	0.35 (9)	1.89 (48)	4.33 (110)	1.61 (47)
6080Y 6085Y	5.67 (144)	3.90 (99)	3.543 (90)	2.36 (60)	0.47 (12)	2.95 (75)	0.47 (12)	0.51 (13)	0.35 (9)	1.93 (49)	5.28 (134)	2.05 (52)

All dimensions are in inches (mm)

Model CNHM, PHHM	Low Speed Shaft				
	U ^[A]	V	S	L1	Key
6060Y 6065Y	0.50 (12.7)	0.98 (25)	10-32UNF	0.63 (16)	1/8 X 1/8 X 0.79 (3.175 x 3.175 x 20.07)
6070Y 6075Y	0.75 (19.05)	1.18 (30)	12-28UNF	0.63 (16)	3/16 X 3/16 X 1.18 (4.762 x 4.762 x 30)
6080Y 6085Y	0.875 (22.23)	1.38 (35)	12-28UNF	0.63 (16)	3/16 X 3/16 X 1.18 (4.762 x 4.762 x 30)

Note: [A] Toleranced dimension, please refer to Table 1 above.

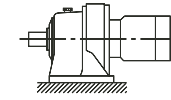

Dimensions Integral Universal Foot Mount

CNHM01-6065DAY ▶ CNHM1-6085Y-EP

XXXX-6XX0/6XX5 Frame sizes have equal dimensions, different ratings. All dimensions are in inches (mm), lbs (kg)

Model	HP x P (kW x P)	O	O1	AB	Without Brake				With Brake					
					C	ML	MP ^[1]	Weight lb (kg)	C	ML	MP ^[1]	MS	MT	Weight lb (kg)
CNHM01-6065DAY	1/8 x 4 (0.1 x 4)	-	-	4.63 (118)	10.20 (259)	1.38 (35)	ø4.69 (ø119)	17 (8)	11.57 (294)	2.76 (70)	ø4.88 (ø124)	1.93 (49)	-	20 (9)
CNHM01-6065Y-AV		-	-		10.55 (268)	2.32 (59)	ø4.88 (ø124)	16 (7)	11.81 (300)	3.58 (91)		2.40 (61)		19 (9)
CNHM01-6065DAY-AV		-	-		11.85 (301)	-	-	19 (9)	13.11 (333)	-		-		22 (10)
CNHM01-6065Y	1/4 x 4 (0.2 x 4)	-	-	4.63 (118)	8.90 (226)	1.38 (35)	ø4.69 (ø119)	13 (6)	10.28 (261)	2.76 (70)	ø4.88 (ø124)	1.93 (49)	-	17 (8)
CNHM02-6065Y		-	-		10.55 (268)	-	-	16 (7)	11.81 (300)	-		19 (9)		
CNHM02-6065Y-AV		-	-		11.34 (288)	2.32 (59)	ø4.88 (ø124)	19 (9)	12.60 (320)	3.58 (91)		2.40 (61)		22 (10)
CNHM03-6065Y	1/3 x 4 (0.25 x 4)	-	-	4.63 (118)	10.55 (268)	-	-	16 (7)	11.81 (300)	-	ø4.88 (ø124)	2.40 (61)	-	19 (9)
CNHM03-6065Y-AV		-	-		11.34 (288)	-	-	19 (9)	12.60 (320)	-		22 (10)		
CNHM01-6075DAY	1/8 x 4 (0.1 x 4)	-	-	4.63 (118)	10.43 (265)	1.38 (35)	ø4.69 (ø119)	18 (8)	11.81 (300)	2.76 (70)	ø4.88 (ø124)	1.93 (49)	-	21 (10)
CNHM01-6075Y-AV		-	-		10.79 (274)	2.32 (59)	ø4.88 (ø124)	16 (7)	12.05 (306)	3.58 (91)		2.40 (61)		19 (9)
CNHM01-6075DAY-AV		-	-		12.09 (307)	-	-	20 (9)	13.35 (339)	-		-		23 (11)
CNHM01-6075Y	1/4 x 4 (0.2 x 4)	-	-	4.63 (118)	9.13 (232)	1.38 (35)	ø4.69 (ø119)	13 (6)	10.51 (267)	2.76 (70)	ø4.88 (ø124)	1.93 (49)	-	17 (8)
CNHM02-6075Y		-	-		10.79 (274)	-	-	16 (7)	12.05 (306)	-		19 (9)		
CNHM02-6075Y-AV		-	-		11.57 (294)	2.32 (59)	ø4.88 (ø124)	19 (9)	12.83 (326)	3.58 (91)		2.40 (61)		22 (10)
CNHM02-6075DAY	1/3 x 4 (0.25 x 4)	-	-	4.63 (118)	12.09 (307)	-	-	20 (9)	13.35 (339)	-	ø4.88 (ø124)	2.40 (61)	-	23 (11)
CNHM02-6075DAY-AV		-	-		12.87 (327)	2.32 (59)	ø4.88 (ø124)	23 (11)	14.13 (359)	3.58 (91)		26 (12)		
CNHM03-6075Y		-	-		10.79 (274)	-	-	16 (7)	12.05 (306)	-		19 (9)		
CNHM03-6075Y-AV	1/2 x 4 (0.4 x 4)	-	-	4.63 (118)	11.57 (294)	-	-	19 (9)	12.83 (326)	-	ø4.88 (ø124)	2.40 (61)	-	22 (10)
CNHM05-6075Y		-	-		11.57 (294)	-	-	19 (9)	12.83 (326)	-		22 (10)		
CNHM01-6085Y	1/8 x 4 (0.1 x 4)	-	-	4.63 (118)	10.16 (258)	1.38 (35)	ø4.69 (ø119)	23 (11)	11.54 (293)	2.76 (70)	ø4.88 (ø124)	1.93 (49)	-	26 (12)
CNHM01-6085Y-AV		-	-		11.81 (300)	-	-	25 (12)	13.07 (332)	-		28 (13)		
CNHM02-6085Y		-	-		12.60 (320)	2.32 (59)	ø4.88 (ø124)	28 (13)	13.86 (352)	3.58 (91)		2.40 (61)		31 (14)
CNHM02-6085Y-AV	1/4 x 4 (0.2 x 4)	-	-	4.63 (118)	11.81 (300)	-	-	25 (12)	13.07 (332)	-	ø4.88 (ø124)	2.40 (61)	-	28 (13)
CNHM03-6085Y		-	-		12.60 (320)	2.32 (59)	ø4.88 (ø124)	28 (13)	13.86 (352)	3.58 (91)		31 (14)		
CNHM03-6085Y-AV		-	-		12.60 (320)	-	-	28 (13)	13.86 (352)	-		31 (14)		
CNHM05-6085Y	1/2 x 4 (0.4 x 4)	-	-	4.63 (118)	14.21 (361)	-	-	35 (16)	15.91 (404)	5.51 (140)	ø5.94 (ø151)	3.66 (93)	3.94 (100)	41 (19)
CNHM05-6085Y-AV		-	-		7.95 (202)	5.67 (144)	14.21 (361)	3.82 (97)	ø5.94 (ø151)	33 (15)		15.91 (404)		5.51 (140)
CNHM08-6085Y	3/4 x 4 (0.55 x 4)	-	-	4.63 (118)	15.85 (403)	-	-	46 (21)	18.35 (466)	6.32 (161)	ø6.22 (ø158)	4.80 (122)	4.25 (108)	55 (25)
CNHM1-6085Y-EP		-	-		7.95 (202)	5.98 (152)	15.85 (403)	-	-	46 (21)		18.35 (466)		6.32 (161)

Note: [1] MP Dimension Symbol ø = Round Fan Cover
MP Dimension Symbol □ = Square Fan Cover

Dimensions Integral Universal Foot Mount

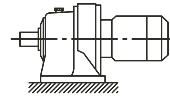

CNHM01-6095Y ▶ CNHM2-6095Y-EP

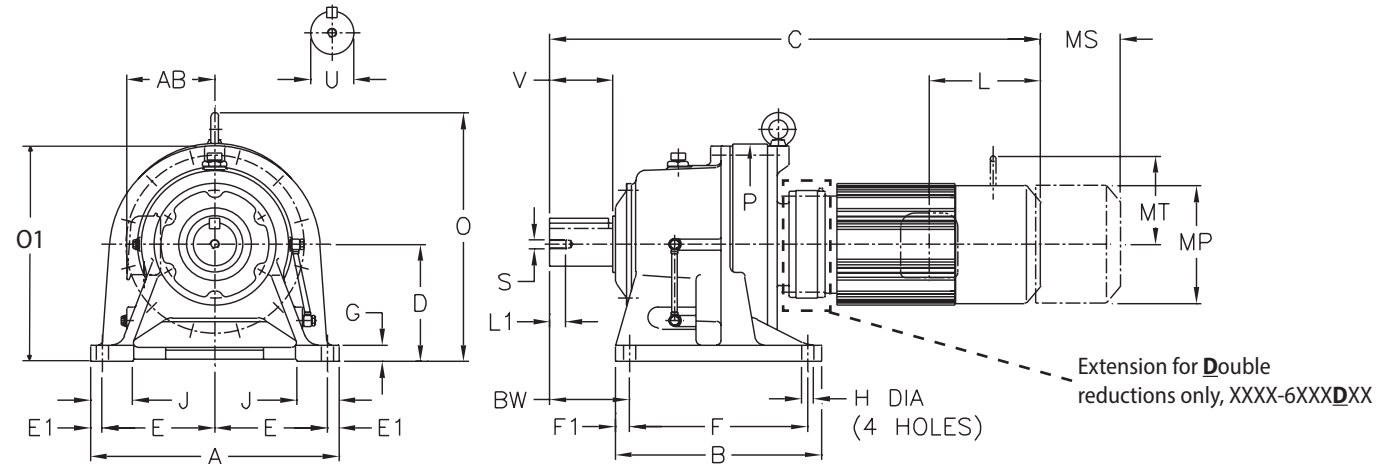

Table 1: Shaft Tolerances All dimensions are in inches (mm)

Low Speed Shaft Nominal Diameter	Tolerance
0.500 through 0.625 (12.700 through 15.875)	+0.0000 / -0.0004 (+0.000 / -0.011)
0.750 through 1.125 (19.050 through 28.757)	+0.0000 / -0.0005 (+0.000 / -0.013)
1.250 through 1.875 (31.750 through 47.625)	+0.0000 / -0.0006 (+0.000 / -0.016)
2.000 through 3.125 (50.800 through 79.375)	+0.0000 / -0.0007 (+0.000 / -0.019)
3.250 through 4.625 (82.550 through 117.475)	+0.0000 / -0.0009 (+0.000 / -0.022)
4.750 through 7.000 (120.650 through 177.800)	+0.0000 / -0.0010 (+0.000 / -0.025)

Note: CNHM units are greased life units, and can be mounted in any position. Dimensions are in inches (mm)

Model CNHM, PHHM	A	B	D	E	E1	F	F1	G	H	J	P	BW
6090Y 6095Y	7.09 (180)	5.31 (135)	3.937 (100)	2.95 (75)	0.59 (15)	3.54 (90)	0.59 (15)	0.47 (12)	0.43 (11)	1.57 (65)	5.91 (175)	2.36 (60)

All dimensions are in inches (mm)

Model CNHM, PHHM	Low Speed Shaft				Key
	U ^[A]	V	S	L1	
6090Y 6095Y	1.125 (28.58)	1.38 (35)	5/16-18UNC	0.79 (20)	1/4 X 1/4 X 1.18 (6.35 x 6.35 x 30)

Note: [A] Toleranced dimension, please refer to Table 1 above.

Dimensions Integral Universal Foot Mount

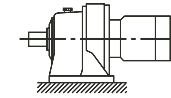

CNHM01-6095Y ▶ CNHM2-6095Y-EP

XXXX-6XX0/6XX5 Frame sizes have equal dimensions, different ratings. All dimensions are in inches (mm), lbs (kg)

Model	HP x P (kW x P)	O	O1	AB	Without Brake				With Brake												
					C	ML	MP ^[1]	Weight lb (kg)	C	ML	MP ^[1]	MS	MT	Weight lb (kg)							
CNHM01-6095Y	1/8 x 4 (0.1 x 4)	-	-	4.63 (118)	10.87 (276)	1.38 (35)	ø4.69 (ø119)	31 (14)	12.24 (311)	2.76 (70)	ø4.88 (ø124)	3.58 (91)	2.40 (61)	-	1.93 (49)	34 (16)					
CNHM01-6095Y-AV		-	-		12.52 (318)	2.32 (59)	ø4.88 (ø124)	33 (15)	13.78 (350)	3.58 (91)					2.40 (61)	36 (16)					
CNHM01-6095DAY		-	-		12.76 (324)	1.38 (35)	ø4.69 (ø119)	34 (16)	14.13 (359)	2.76 (70)					1.93 (49)	38 (17)					
CNHM01-6095DAY-AV		-	-		14.41 (366)			37 (17)	15.67 (398)							40 (18)					
CNHM02-6095Y	1/4 x 4 (0.2 x 4)	-	-		12.52 (318)			33 (15)	13.78 (350)												36 (16)
CNHM02-6095Y-AV		-	-		13.31 (338)			36 (16)	14.57 (370)												39 (18)
CNHM02-6095DAY		-	-		14.41 (366)			37 (17)	15.67 (398)												40 (18)
CNHM02-6095DAY-AV		-	-		15.20 (386)			40 (18)	16.46 (418)												43 (20)
CNHM03-6095Y	1/3 x 4 (0.25 x 4)	-	-		12.52 (318)	2.32 (59)	ø4.88 (ø124)	33 (15)	13.78 (350)	3.58 (91)					2.40 (61)						36 (16)
CNHM03-6095Y-AV		-	-		13.31 (338)			36 (16)	14.57 (370)												39 (18)
CNHM03-6095DAY		-	-		14.41 (366)			37 (17)	15.67 (398)												40 (18)
CNHM03-6095DAY-AV		-	-		15.20 (386)			40 (18)	16.46 (418)												43 (20)
CNHM05-6095Y	1/2 x 4 (0.4 x 4)	-	-	13.31 (338)			36 (16)	14.57 (370)								39 (18)					
CNHM05-6095Y-AV		8.35 (212)	-	5.67 (144)	14.92 (379)	3.82 (97)	ø5.94 (ø151)	43 (20)	16.61 (422)	5.51 (140)	ø5.94 (ø151)	3.66 (93)	3.94 (100)			49 (22)					
CNHM05-6095DAY		-	-	4.63 (118)	15.20 (386)	2.32 (59)	ø4.88 (ø124)	40 (18)	16.46 (418)	3.58 (91)	ø4.88 (ø124)	2.40 (61)	-			43 (20)					
CNHM08-6095Y		3/4 x 4 (0.55 x 4)	-	-	5.67 (144)	14.92 (379)	3.82 (97)	ø5.94 (ø151)	40 (19)	16.61 (422)	5.51 (140)	ø5.94 (ø151)	3.66 (93)	3.94 (100)			46 (21)				
CNHM08-6095Y-AV	8.54 (217)	-	-	5.86 (149)	16.22 (412)	3.94 (100)	ø6.30 (ø160)	51 (23)	18.66 (474)	6.38 (162)	ø6.30 (ø160)	4.53 (115)	4.29 (109)			62 (28)					
CNHM1-6095Y-EP	1 x 4 (0.75 x 4)	8.35 (212)	-	5.98 (152)	16.65 (423)		□6.22 (□158)	56 (26)	19.15 (487)	6.32 (161)	□6.22 (□158)	4.80 (122)	4.25 (108)			66 (30)					
CNHM1H-6095Y-EP	1.5 x 4 (1.1 x 4)	8.54 (217)	-	6.16 (156)	17.72 (450)	3.82 (97)	□6.57 (□167)	64 (29)	20.45 (520)	6.56 (167)	□6.57 (□167)	5.04 (128)	4.61 (117)			75 (34)					
CNHM2-6095Y-EP	2 x 4 (1.5 x 4)	8.54 (217)	-					66 (30)								78 (36)					

Note: [1] MP Dimension Symbol ø = Round Fan Cover
MP Dimension Symbol □ = Square Fan Cover

Dimensions Integral Universal Foot Mount

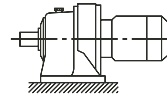

CNHM01-6105DAY ▶ CNHM5-6115Y-EP

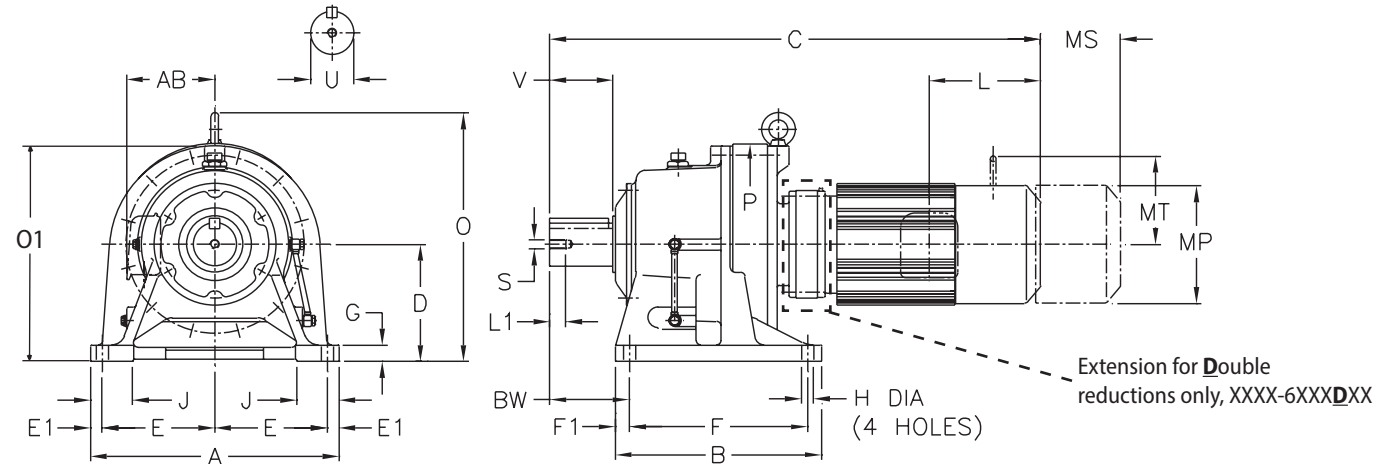

Table 1: Shaft Tolerances All dimensions are in inches (mm)

Low Speed Shaft Nominal Diameter	Tolerance
0.500 through 0.625 (12.700 through 15.875)	+0.0000 / -0.0004 (+0.000 / -0.011)
0.750 through 1.125 (19.050 through 28.757)	+0.0000 / -0.0005 (+0.000 / -0.013)
1.250 through 1.875 (31.750 through 47.625)	+0.0000 / -0.0006 (+0.000 / -0.016)
2.000 through 3.125 (50.800 through 79.375)	+0.0000 / -0.0007 (+0.000 / -0.019)
3.250 through 4.625 (82.550 through 117.475)	+0.0000 / -0.0009 (+0.000 / -0.022)
4.750 through 7.000 (120.650 through 177.800)	+0.0000 / -0.0010 (+0.000 / -0.025)

Note: CNHM units are greased life units, and can be mounted in any position. Dimensions are in inches (mm)

Model CNHM, PHHM	A	B	D	E	E1	F	F1	G	H	J	P	BW
6100Y 6105Y	7.09 (180)	5.31 (135)	3.937 (100)	2.95 (75)	0.59 (15)	3.54 (90)	0.59 (15)	0.47 (12)	0.43 (11)	1.57 (40)	5.91 (150)	2.36 (60)
610HY	7.09 (180)	5.31 (135)	4.724 (120)	2.95 (75)	0.59 (15)	3.54 (90)	0.59 (15)	0.47 (12)	0.43 (11)	1.77 (45)	5.91 (150)	2.36 (60)
6110Y 6115Y	7.09 (180)	5.31 (135)	4.724 (120)	2.95 (75)	0.59 (15)	3.54 (90)	0.59 (15)	0.47 (12)	0.43 (11)	1.77 (45)	6.38 (162)	2.36 (60)

All dimensions are in inches (mm)

Model CNHM, PHHM	Low Speed Shaft				
	U ^[A]	V	S	L1	Key
6100Y 6105Y	1.125 (28.58)	1.38 (35)	5/16-18UNC	0.79 (20)	1/4 X 1/4 X 1.18 (6.35 x 6.35 x 30)
610HY	1.125 (28.58)	1.38 (35)	5/16-18UNC	0.79 (20)	1/4 X 1/4 X 1.18 (6.35 x 6.35 x 30)
6110Y 6115Y	1.25 (31.75)	1.77 (45)	5/16-18UNC	0.79 (20)	1/4 x 1/4 x 1.46 (6.35 x 6.35 x 37)

Note: [A] Toleranced dimension, please refer to Table 1 above.

Dimensions Integral Universal Foot Mount

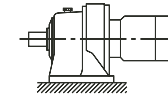

CNHM01-6105DAY ▶ CNHM5-6115Y-EP

XXXX-6XX0/6XX5 Frame sizes have equal dimensions, different ratings. All dimensions are in inches (mm), lbs (kg)

Model	HP x P (kW x P)	O	O1	AB	Without Brake				With Brake									
					C	ML	MP ^[1]	Weight lb (kg)	C	ML	MP ^[1]	MS	MT	Weight lb (kg)				
CNHM01-6105DAY	1/8 x 4 (0.1 x 4)	-	-	4.63 (118)	13.31 (338)	1.38 (35)	ø4.69 (ø119)	41 (19)	14.69 (373)	2.76 (70)	ø4.88 (ø124)	2.40 (61)	-	1.93 (49)	44 (20)			
CNHM01-6105DAY-AV					14.96 (380)			43 (20)	16.22 (412)								46 (21)	
CNHM02-6105Y	1/4 x 4 (0.2 x 4)				13.07 (332)			37 (17)	14.33 (364)								40 (19)	
CNHM02-6105Y-AV					13.86 (352)			40 (19)	15.12 (384)								43 (20)	
CNHM02-6105DAY					14.96 (380)			43 (20)	16.22 (412)								46 (21)	
CNHM02-6105DAY-AV					15.75 (400)			46 (21)	17.01 (432)								49 (23)	
CNHM03-6105Y		1/3 x 4 (0.25 x 4)				13.07 (332)			37 (17)	14.33 (364)								40 (19)
CNHM03-6105Y-AV						13.86 (352)			40 (19)	15.12 (384)								43 (20)
CNHM03-6105DAY					14.96 (380)			43 (20)	16.22 (412)								46 (21)	
CNHM03-6105DAY-AV					15.75 (400)			46 (21)	17.01 (432)								49 (23)	
CNHM05-6105Y	1/2 x 4 (0.4 x 4)					13.86 (352)			40 (19)	15.12 (384)								43 (20)
CNHM05-6105Y-AV						15.47 (393)	3.82 (97)	ø5.94 (ø151)	48 (22)	17.17 (436)				5.51 (140)	ø5.94 (ø151)	3.66 (93)	3.94 (100)	53 (25)
CNHM05-6105DAY				15.75 (400)	2.32 (59)	ø4.88 (ø124)	46 (21)	17.01 (432)	3.58 (91)	ø4.88 (ø124)	2.40 (61)	-	49 (23)					
CNHM08-6105Y		3/4 x 4 (0.55 x 4)			15.47 (393)	3.82 (97)	ø5.94 (ø151)	45 (21)	17.17 (436)	5.51 (140)	ø5.94 (ø151)	3.66 (93)	3.94 (100)	51 (23)				
CNHM08-6105Y-AV					16.77 (426)	3.94 (100)	ø6.30 (ø160)	56 (26)	19.21 (488)	6.38 (162)	ø6.30 (ø160)	4.53 (115)	4.29 (109)	67 (30)				
CNHM1-6105Y-EP			1 x 4 (0.75 x 4)	8.35 (212)	-	5.98 (152)	17.20 (437)	□6.22 (□158)	61 (28)	19.70 (501)	6.32 (161)	□6.22 (□158)	4.80 (122)	4.25 (108)	71 (32)			
CNHM1H-6105Y-EP	1.5 x 4 (1.1 x 4)	8.54 (217)	-	6.16 (156)	18.27 (464)	□6.57 (□167)	68 (31)	21.00 (534)	6.56 (167)	□6.57 (□167)	5.04 (128)	4.61 (117)	80 (36)					
CNHM2-6105Y-EP	2 x 4 (1.5 x 4)	8.54 (217)	-	6.16 (156)	18.27 (464)	□6.57 (□167)	71 (33)	21.00 (534)	6.56 (167)	□6.57 (□167)	5.04 (128)	4.61 (117)	83 (38)					
CNHM3-6105Y-EP	3 x 4 (2.2 x 4)	8.86 (225)	-	6.71 (170)	19.09 (485)	□7.24 (□184)	87 (40)	22.17 (563)	7.60 (193)	□7.24 (□184)	5.43 (138)	5.04 (128)	104 (47)					
CNHM1-610HY-EP	1 x 4 (0.75 x 4)	9.13 (232)	-	5.98 (152)	17.20 (437)	□6.22 (□158)	63 (29)	19.70 (501)	6.32 (161)	□6.22 (□158)	4.80 (122)	4.25 (108)	73 (33)					
CNHM1H-610HY-EP	1.5 x 4 (1.1 x 4)	9.33 (237)	-	6.16 (156)	18.27 (464)	□6.57 (□167)	70 (32)	21.00 (534)	6.56 (167)	□6.57 (□167)	5.04 (128)	4.61 (117)	82 (37)					
CNHM2-610HY-EP	2 x 4 (1.5 x 4)	9.33 (237)	-	6.16 (156)	18.27 (464)	□6.57 (□167)	73 (34)	21.00 (534)	6.56 (167)	□6.57 (□167)	5.04 (128)	4.61 (117)	85 (39)					
CNHM3-610HY-EP	3 x 4 (2.2 x 4)	9.65 (245)	-	6.71 (170)	19.09 (485)	□7.24 (□184)	89 (41)	22.17 (563)	7.60 (193)	□7.24 (□184)	5.43 (138)	5.04 (128)	106 (48)					
CNHM05-6115Y	1/2 x 4 (0.4 x 4)			4.63 (118)	14.25 (362)	2.32 (59)	ø4.88 (ø124)	47 (22)	15.51 (394)	3.58 (91)	ø4.88 (ø124)	2.40 (61)	-	50 (23)				
CNHM05-6115Y-AV				5.67 (144)	15.87 (403)	3.82 (97)	ø5.94 (ø151)	54 (25)	17.56 (446)	5.51 (140)	ø5.94 (ø151)	3.66 (93)	3.94 (100)	59 (27)				
CNHM08-6115Y		3/4 x 4 (0.55 x 4)			5.67 (144)	17.17 (436)	3.94 (100)	ø6.30 (ø160)	60 (28)	19.61 (498)	6.38 (162)	ø6.30 (ø160)	4.53 (115)	4.29 (109)	71 (32)			
CNHM1-6115Y-EP	1 x 4 (0.75 x 4)		9.25 (235)	-	5.98 (152)	17.60 (447)	□6.22 (□158)	65 (30)	20.10 (511)	6.32 (161)	□6.22 (□158)	4.80 (122)	4.25 (108)	75 (34)				
CNHM1H-6115Y-EP	1.5 x 4 (1.1 x 4)		9.33 (237)	-	6.16 (156)	18.66 (474)	□6.57 (□167)	72 (33)	21.40 (544)	6.56 (167)	□6.57 (□167)	5.04 (128)	4.61 (117)	84 (38)				
CNHM2-6115Y-EP	2 x 4 (1.5 x 4)	9.33 (237)	-	6.16 (156)	18.66 (474)	□6.57 (□167)	75 (34)	21.40 (544)	6.56 (167)	□6.57 (□167)	5.04 (128)	4.61 (117)	87 (40)					
CNHM3-6115Y-EP	3 x 4 (2.2 x 4)	9.65 (245)	-	6.71 (170)	18.54 (471)	□7.24 (□184)	87 (40)	21.61 (549)	7.60 (193)	□7.24 (□184)	5.43 (138)	5.04 (128)	104 (47)					
CNHM5-6115Y-EP	5 x 4 (3.7 x 4)	10.75 (273)	-	7.34 (186)	19.61 (498)	□8.74 (□222)	113 (51)	23.17 (589)	8.21 (209)	□8.74 (□222)	6.02 (153)	6.30 (160)	136 (62)					

Note: [1] MP Dimension Symbol ø = Round Fan Cover
MP Dimension Symbol □ = Square Fan Cover

Dimensions Integral Universal Foot Mount

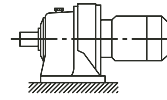

CNHM01-6125DBY ▶ CNHM8-612HY-EP

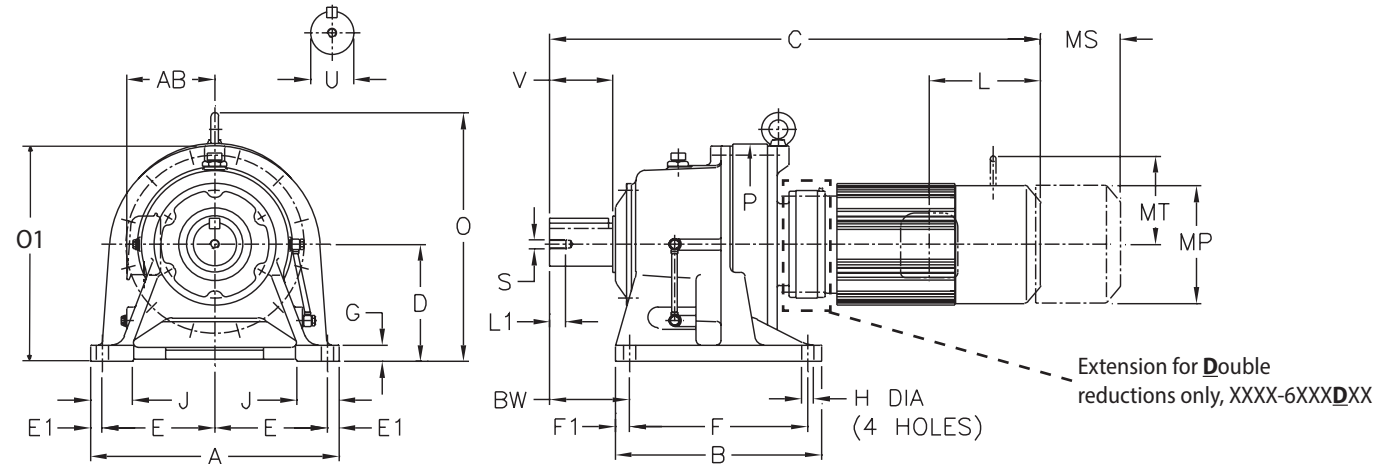

Table 1: Shaft Tolerances All dimensions are in inches (mm)

Low Speed Shaft Nominal Diameter	Tolerance
0.500 through 0.625 (12.700 through 15.875)	+0.0000 / -0.0004 (+0.000 / -0.011)
0.750 through 1.125 (19.050 through 28.757)	+0.0000 / -0.0005 (+0.000 / -0.013)
1.250 through 1.875 (31.750 through 47.625)	+0.0000 / -0.0006 (+0.000 / -0.016)
2.000 through 3.125 (50.800 through 79.375)	+0.0000 / -0.0007 (+0.000 / -0.019)
3.250 through 4.625 (82.550 through 117.475)	+0.0000 / -0.0009 (+0.000 / -0.022)
4.750 through 7.000 (120.650 through 177.800)	+0.0000 / -0.0010 (+0.000 / -0.025)

Note: CNHM units are greased life units, and can be mounted in any position. Dimensions are in inches (mm)

Model CNHM, PHHM	A	B	D	E	E1	F	F1	G	H	J	P	BW
6120Y 6125Y	9.06 (230)	6.10 (155)	4.724 (120)	3.74 (95)	0.79 (20)	4.53 (115)	0.79 (20)	0.59 (15)	0.55 (14)	2.17 (55)	8.03 (204)	3.23 (82)
612HY	9.06 (230)	6.10 (155)	5.512 (140)	3.74 (95)	0.79 (20)	4.53 (115)	0.79 (20)	0.59 (15)	0.55 (14)	2.17 (55)	8.03 (204)	3.23 (82)

All dimensions are in inches (mm)

Model CNHM, PHHM	Low Speed Shaft				
	U ^[A]	V	S	L1	Key
6120Y 6125Y	1.50 (38.1)	2.17 (55)	5/16-18UNC	0.79 (20)	3/8 x 3/8 x 1.77 (9.525 x 9.525 x 45)
612HY	1.50 (38.1)	2.17 (55)	5/16-18UNC	0.79 (20)	3/8 x 3/8 x 1.77 (9.525 x 9.525 x 45)

Note: [A] Toleranced dimension, please refer to Table 1 above.

Dimensions Integral Universal Foot Mount

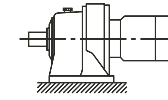

CNHM01-6125DBY ▶ CNHM8-612HY-EP

XXXX-6XX0/6XX5 Frame sizes have equal dimensions, different ratings. All dimensions are in inches (mm), lbs (kg)

Model	HP x P (kW x P)	O	O1	AB	Without Brake				With Brake											
					C	ML	MP ^[1]	Weight lb (kg)	C	ML	MP ^[1]	MS	MT	Weight lb (kg)						
CNHM01-6125DBY	1/8 x 4 (0.1 x 4)	-	-	4.63 (118)	15.20 (386)	1.38 (35)	ø4.69 (ø119)	70 (32)	16.57 (421)	2.76 (70)	ø4.88 (ø124)	2.40 (61)	-	74 (34)						
CNHM01-6125DBY-AV					16.85 (428)			72 (33)	18.11 (460)								75 (34)			
CNHM02-6125DAY	1/4 x 4 (0.2 x 4)	-	-		16.38 (416)	2.32 (59)	ø4.88 (ø124)	67 (31)	17.64 (448)	3.58 (91)				ø4.88 (ø124)	2.40 (61)	-	70 (32)			
CNHM02-6125DBY					16.85 (428)			72 (33)	18.11 (460)								75 (34)			
CNHM02-6125DAY-AV					17.17 (436)			70 (32)	18.43 (468)								74 (34)			
CNHM02-6125DBY-AV					17.64 (448)			75 (34)	18.90 (480)								78 (36)			
CNHM03-6125DBY		1/3 x 4 (0.25 x 4)	-		-			16.85 (428)	72 (33)								18.11 (460)	75 (34)		
CNHM03-6125DBY-AV								17.64 (448)	75 (34)								18.90 (480)	78 (36)		
CNHM05-6125Y	1/2 x 4 (0.4 x 4)	-	-		15.24 (387)			66 (30)	16.50 (419)								69 (32)			
CNHM05-6125Y-AV					10.12 (257)	5.67 (144)	16.65 (423)	3.82 (97)	ø5.94 (ø151)	73 (34)				18.35 (466)	ø5.94 (ø151)	3.66 (93)	3.94 (100)	79 (36)		
CNHM05-6125DBY					4.63 (118)	17.64 (448)	2.32 (59)	ø4.88 (ø124)	75 (34)	18.90 (480)	3.58 (91)	2.40 (61)	-	78 (36)						
CNHM05-6125DBY-AV						10.12 (257)			19.25 (489)	3.82 (97)	ø5.94 (ø151)			83 (38)	20.94 (532)	5.51 (140)	ø5.94 (ø151)	3.66 (93)	3.94 (100)	88 (40)
CNHM08-6125Y						5.67 (144)	16.65 (423)		71 (32)	18.35 (466)				77 (35)						
CNHM08-6125Y-AV	3/4 x 4 (0.55 x 4)	-	-	10.12 (257)	5.86 (149)	17.95 (456)	3.94 (100)	ø6.30 (ø160)	79 (36)	20.39 (518)	6.38 (162)	ø6.30 (ø160)	4.53 (115)	4.29 (109)	90 (41)					
CNHM08-6125DBY						19.25 (489)	3.82 (97)	ø5.94 (ø151)	80 (37)	20.94 (532)	5.51 (140)	ø5.94 (ø151)	3.66 (93)	3.94 (100)	86 (39)					
CNHM08-6125DBY-AV						10.12 (257)	5.86 (149)	20.55 (522)	3.94 (100)	ø6.30 (ø160)	91 (41)	22.99 (584)	6.38 (162)	ø6.30 (ø160)	4.53 (115)	4.29 (109)	102 (46)			
CNHM1-6125Y-EP	1 x 4 (0.75 x 4)	-	-	10.12 (257)		18.39 (467)		ø6.22 (ø158)	84 (38)	20.89 (531)	6.32 (161)	ø6.22 (ø158)	4.80 (122)	4.25 (108)	94 (43)					
CNHM1-6125DBY-EP						10.12 (257)	5.98 (152)	20.98 (533)	96 (44)	23.48 (597)								106 (48)		
CNHM1H-6125Y-EP	1.5 x 4 (1.1 x 4)	-	-	10.12 (257)		19.45 (494)	3.82 (97)	ø6.57 (ø167)	91 (42)	22.19 (564)	6.56 (167)	ø6.57 (ø167)	5.04 (128)	4.61 (117)	103 (47)					
CNHM1H-6125DBY-EP						10.12 (257)			6.16 (156)	22.05 (560)					103 (47)	24.78 (630)				115 (52)
CNHM2-6125Y-EP									19.45 (494)						94 (43)	22.19 (564)				106 (48)
CNHM2-6125DBY-EP	2 x 4 (1.5 x 4)	-	-	10.12 (257)		22.05 (560)			106 (48)	24.78 (630)				118 (54)						
CNHM3-6125Y-EP	3 x 4 (2.2 x 4)	10.12 (257)	-	6.71 (170)	18.86 (479)	4.53 (115)	ø7.24 (ø184)	107 (49)	21.93 (557)	7.60 (193)	ø7.24 (ø184)	5.43 (138)	5.04 (128)	124 (56)						
CNHM5-6125Y-EP	5 x 4 (3.7 x 4)	10.75 (273)	-	7.34 (186)	20.31 (516)	4.65 (118)	ø8.74 (ø222)	133 (60)	23.88 (607)	8.21 (209)	ø8.74 (ø222)	6.02 (153)	6.30 (160)	156 (71)						
CNHM8-6125Y-EP	7.5 x 4 (5.5 x 4)	10.75 (273)	-		22.01 (559)			166 (76)	25.57 (650)					190 (87)						
CNHM1-612HY-EP	1 x 4 (0.75 x 4)	10.91 (277)	-	5.98 (152)	18.39 (467)		ø6.22 (ø158)	86 (39)	20.89 (531)	6.32 (161)	ø6.22 (ø158)	4.80 (122)	4.25 (108)	96 (44)						
CNHM1H-612HY-EP	1.5 x 4 (1.1 x 4)	10.91 (277)	-	6.16 (156)	19.45 (494)	3.82 (97)	ø6.57 (ø167)	93 (43)	22.19 (564)	6.56 (167)	ø6.57 (ø167)	5.04 (128)	4.61 (117)	105 (48)						
CNHM2-612HY-EP	2 x 4 (1.5 x 4)	10.91 (277)	-		19.45 (494)			96 (44)	22.19 (564)					108 (49)						
CNHM3-612HY-EP	3 x 4 (2.2 x 4)	10.91 (277)	-	6.71 (170)	18.86 (479)	4.53 (115)	ø7.24 (ø184)	109 (50)	21.93 (557)	7.60 (193)	ø7.24 (ø184)	5.43 (138)	5.04 (128)	126 (57)						
CNHM5-612HY-EP	5 x 4 (3.7 x 4)	11.54 (293)	-	7.34 (186)	20.31 (516)	4.65 (118)	ø8.74 (ø222)	135 (61)	23.88 (607)	8.21 (209)	ø8.74 (ø222)	6.02 (153)	6.30 (160)	159 (72)						
CNHM8-612HY-EP	7.5 x 4 (5.5 x 4)	11.54 (293)	-		22.01 (559)			169 (77)	25.57 (650)					192 (88)						

Note: [1] MP Dimension Symbol ø = Round Fan Cover
MP Dimension Symbol □ = Square Fan Cover

Dimensions Integral Horizontal Foot Mount

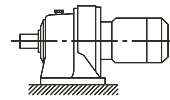

CHHM02-6135DAY ▶ CHHM15-6135Y-EP

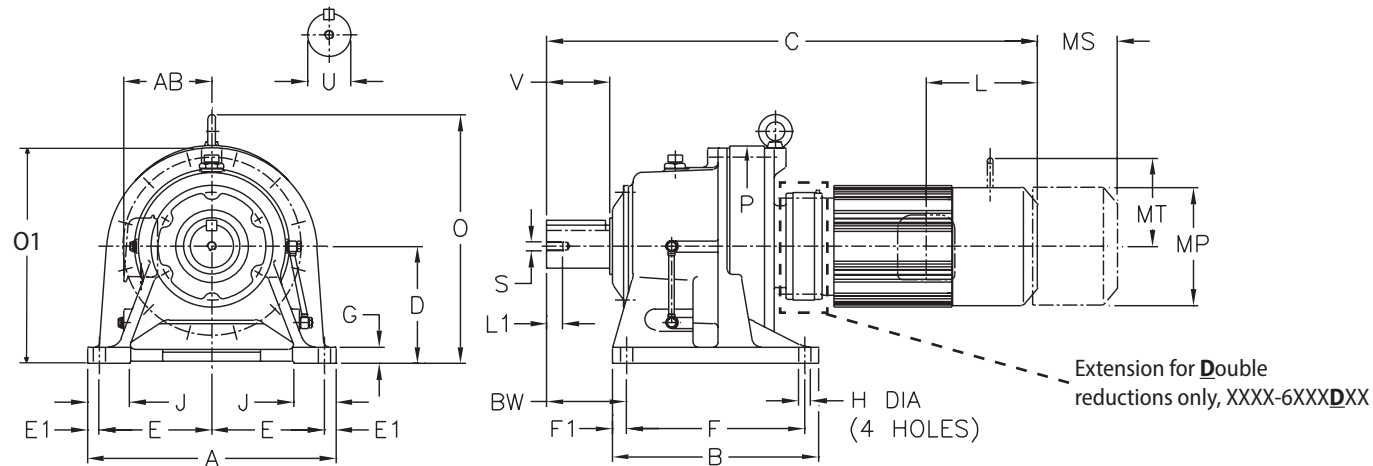

Table 1: Shaft Tolerances All dimensions are in inches (mm)

Low Speed Shaft Nominal Diameter	Tolerance Inches
0.500 through 0.625 (12.700 through 15.875)	+0.0000 / -0.0004 (+0.000 / -0.011)
0.750 through 1.125 (19.050 through 28.757)	+0.0000 / -0.0005 (+0.000 / -0.013)
1.250 through 1.875 (31.750 through 47.625)	+0.0000 / -0.0006 (+0.000 / -0.016)
2.000 through 3.125 (50.800 through 79.375)	+0.0000 / -0.0007 (+0.000 / -0.019)
3.250 through 4.625 (82.550 through 117.475)	+0.0000 / -0.0009 (+0.000 / -0.022)
4.750 through 7.000 (120.650 through 177.800)	+0.0000 / -0.0010 (+0.000 / -0.025)

Note: CHHM units are oil lubricated standard, must be installed as shown above.

Dimensions are in inches (mm)

Model	A	B	D	E	E1	F	F1	G	H	J	P	BW
6130Y	12.99	7.68	5.906	5.71	0.79	5.71	0.98	0.87	0.71	2.56	9.06	3.94
6135Y	(330)	(195)	(150)	(145)	(20)	(145)	(25)	(22)	(18)	(65)	(230)	(100)

All dimensions are in inches (mm)

Model	Low Speed Shaft				Key
	U ^[A]	V	S	L1	
6130Y 6135Y	1.88 (47.625)	2.76 (70)	3/8-16UNC	0.79 (20)	1/2 x 1/2 x 2.17 (12.7 x 12.7 x 55)

Note: [A] Toleranced dimension, please refer to Table 1 above.

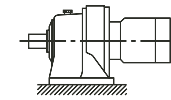

Dimensions Integral Horizontal Foot Mount

CHHM02-6135DAY ▶ CHHM15-6135Y-EP

XXXX-6XX0/6XX5 Frame sizes have equal dimensions, different ratings.

All dimensions are in inches (mm), lbs (kg)

Model	HP x P (kW x P)	O	O1	AB	Without Brake				With Brake					
					C	ML	MP ^[1]	Weight lb (kg)	C	ML	MP ^[1]	MS	MT	Weight lb (kg)
CHHM02-6135DAY	1/4 x 4 (0.2 x 4)	-	-	4.63 (118)	18.50 (470)	2.32 (59)	ø4.88 (ø124)	100 (46)	19.76 (502)	3.58 (91)	ø4.88 (ø124)	2.40 (61)	-	103 (47)
CHHM02-6135DAY-AV		19.29 (490)	20.55 (522)		107 (49)									
CHHM02-6135DCY		19.41 (493)	20.67 (525)		113 (52)									
CHHM02-6135DCY-AV		20.20 (513)	21.46 (545)		116 (53)									
CHHM03-6135DCY		19.41 (493)	20.67 (525)		113 (52)									
CHHM03-6135DCY-AV		20.20 (513)	21.46 (545)		116 (53)									
CHHM05-6135DCY	1/2 x 4 (0.4 x 4)	-	-	5.67 (144)	21.81 (554)	3.82 (97)	ø5.94 (ø151)	120 (55)	23.50 (597)	5.51 (140)	ø5.94 (ø151)	3.66 (93)	3.94 (100)	126 (58)
CHHM05-6135DCY-AV		20.47 (520)	20.47 (520)		120 (55)									
CHHM08-6135Y	3/4 x 4 (0.55 x 4)	-	-	5.86 (149)	18.78 (477)	3.94 (100)	ø6.30 (ø160)	114 (52)	20.47 (520)	6.38 (162)	ø6.30 (ø160)	4.53 (115)	4.29 (109)	120 (55)
CHHM08-6135Y-AV		20.08 (510)	22.52 (572)		123 (56)									
CHHM08-6135DCY		21.81 (554)	23.50 (597)		124 (56)									
CHHM08-6135DCY-AV		23.11 (587)	25.55 (649)		139 (63)									
CHHM1-6135Y-EP	1 x 4 (0.75 x 4)	-	10.43 (265)	5.98 (152)	20.51 (521)	3.82 (97)	ø6.22 (ø158)	127 (58)	23.01 (585)	6.32 (161)	ø6.22 (ø158)	4.80 (122)	4.25 (108)	137 (63)
CHHM1-6135DCY-EP		11.81 (300)	26.04 (662)		133 (61)									
CHHM1H-6135Y-EP	1.5 x 4 (1.1 x 4)	10.51 (267)	-	6.16 (156)	21.57 (548)	3.82 (97)	ø6.57 (ø167)	134 (61)	24.31 (618)	6.56 (167)	ø6.57 (ø167)	5.04 (128)	4.61 (117)	146 (66)
CHHM1H-6135DCY-EP		11.81 (300)	27.34 (695)		141 (64)									
CHHM2-6135Y-EP	2 x 4 (1.5 x 4)	10.51 (267)	-	6.71 (170)	21.57 (548)	4.53 (115)	ø7.24 (ø184)	137 (63)	24.31 (618)	7.60 (193)	ø7.24 (ø184)	5.43 (138)	5.04 (128)	149 (68)
CHHM2-6135DCY-EP		11.81 (300)	27.34 (695)		144 (66)									
CHHM3-6135Y-EP	3 x 4 (2.2 x 4)	10.83 (275)	-	7.34 (186)	20.98 (533)	4.65 (118)	ø8.74 (ø222)	149 (68)	24.06 (611)	8.21 (209)	ø8.74 (ø222)	6.02 (153)	6.30 (160)	165 (75)
CHHM3-6135DCY-EP		11.81 (300)	28.50 (724)		160 (73)									
CHHM5-6135Y-EP	5 x 4 (3.7 x 4)	11.93 (303)	-	7.34 (186)	22.24 (565)	4.65 (118)	ø8.74 (ø222)	173 (79)	25.81 (656)	8.21 (209)	ø8.74 (ø222)	6.02 (153)	6.30 (160)	197 (90)
CHHM8-6135Y-EP	7.5 x 4 (5.5 x 4)	11.93 (303)	-	7.34 (186)	23.94 (608)	4.65 (118)	ø8.74 (ø222)	207 (94)	27.50 (699)	8.21 (209)	ø8.74 (ø222)	6.02 (153)	6.30 (160)	231 (105)
CHHM10-6135Y-EP	10 x 4 (7.5 x 4)	12.68 (322)	-	9.04 (230)	25.43 (646)	5.43 (138)	ø10.24 (ø260)	234 (106)	29.57 (751)	9.57 (243)	ø10.24 (ø260)	7.44 (189)	7.32 (186)	278 (126)
CHHM15-6135Y-EP	15 x 4 (11 x 4)	12.68 (322)	-	9.04 (230)	27.87 (708)	5.43 (138)	ø10.24 (ø260)	247 (112)	32.01 (813)	9.57 (243)	ø10.24 (ø260)	7.44 (189)	7.32 (186)	291 (132)

Note: [1] MP Dimension Symbol ø = Round Fan Cover
MP Dimension Symbol □ = Square Fan Cover

Dimensions Integral Horizontal Foot Mount

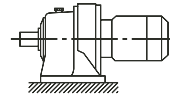

CHHM02-6145DBY ▶ CHHM20-614HY-EP

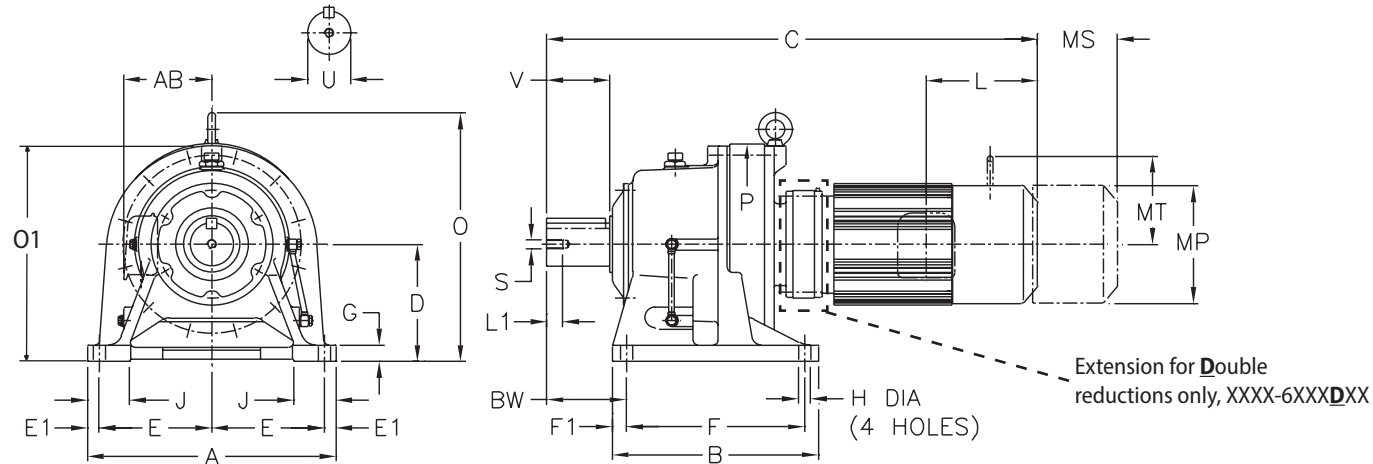

Table 1: Shaft Tolerances All dimensions are in inches (mm)

Low Speed Shaft Nominal Diameter	Tolerance Inches
0.500 through 0.625 (12.700 through 15.875)	+0.0000 / -0.0004 (+0.000 / -0.011)
0.750 through 1.125 (19.050 through 28.757)	+0.0000 / -0.0005 (+0.000 / -0.013)
1.250 through 1.875 (31.750 through 47.625)	+0.0000 / -0.0006 (+0.000 / -0.016)
2.000 through 3.125 (50.800 through 79.375)	+0.0000 / -0.0007 (+0.000 / -0.019)
3.250 through 4.625 (82.550 through 117.475)	+0.0000 / -0.0009 (+0.000 / -0.022)
4.750 through 7.000 (120.650 through 177.800)	+0.0000 / -0.0010 (+0.000 / -0.025)

Note: CHHM units are oil lubricated standard, must be installed as shown above.

Dimensions are in inches (mm)

Model	A	B	D	E	E1	F	F1	G	H	J	P	BW
6140Y	12.99	7.68	5.906	5.71	0.79	5.71	0.98	0.87	0.71	2.56	9.06	4.72
6145Y	(330)	(195)	(150)	(145)	(20)	(145)	(25)	(22)	(18)	(65)	(230)	(120)
614HY	12.99	7.68	6.299	5.71	0.79	5.71	0.98	0.87	0.71	2.76	9.06	4.72
	(330)	(195)	(160)	(145)	(20)	(145)	(25)	(22)	(18)	(70)	(230)	(120)

All dimensions are in inches (mm)

Model	Low Speed Shaft				Key
	U ^[A]	V	S	L1	
6140Y	1.88	3.54	3/8-16UNC	0.79	1/2 x 1/2 x 2.95 (12.7 x 12.7 x 75)
6145Y	(47.625)	(90)		(20)	
614HY	1.88	3.54	3/8-16UNC	0.79	1/2 x 1/2 x 2.95 (12.7 x 12.7 x 75)
	(47.625)	(90)		(20)	

Note: [A] Toleranced dimension, please refer to Table 1 above.

Dimensions Integral Horizontal Foot Mount

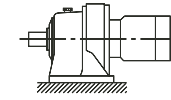

CHHM02-6145DBY ▶ CHHM20-614HY-EP

XXXX-6XX0/6XX5 Frame sizes have equal dimensions, different ratings.

All dimensions are in inches (mm), lbs (kg)

Model	HP x P (kW x P)	O	O1	AB	Without Brake				With Brake						
					C	ML	MP ^[1]	Weight lb (kg)	C	ML	MP ^[1]	MS	MT	Weight lb (kg)	
CHHM02-6145DBY	1/4 x 4 (0.2 x 4)	-	-		19.65 (499)			108 (49)	20.91 (531)						111 (50)
CHHM02-6145DBY-AV		-	-		20.43 (519)			111 (50)	21.69 (551)						114 (52)
CHHM03-6145DBY	1/3 x 4 (0.25 x 4)	-	-	4.63 (118)	19.65 (499)	2.32 (59)	ø4.88 (ø124)	108 (49)	20.91 (531)	3.58 (91)	ø4.88 (ø124)	2.40 (61)	-		111 (50)
CHHM03-6145DBY-AV		-	-		20.43 (519)			111 (50)	21.69 (551)						114 (52)
CHHM05-6145DBY	1/2 x 4 (0.4 x 4)	-	-					111 (50)							114 (52)
CHHM05-6145DBY-AV		11.81 (300)	-	5.67 (144)	22.05 (560)	3.82 (97)	ø5.94 (ø151)	118 (54)	23.74 (603)	5.51 (140)	ø5.94 (ø151)	3.66 (93)	3.94 (100)		124 (56)
CHHM08-6145DBY	3/4 x 4 (0.55 x 4)	-	-					115 (53)							121 (55)
CHHM08-6145DBY-AV		11.81 (300)	-	5.86 (149)	23.35 (593)	3.94 (100)	ø6.30 (ø160)	126 (57)	25.79 (655)	6.38 (162)	ø6.30 (ø160)	4.53 (115)	4.29 (109)		137 (62)
CHHM1-614HY-EP		-	10.83 (275)					134 (61)	23.80 (605)						144 (66)
CHHM1-6145Y-EP	1 x 4 (0.75 x 4)	-	10.43 (265)	5.98 (152)	21.30 (541)			130 (59)	25.10 (638)	6.32 (161)	ø6.22 (ø158)	4.80 (122)	4.25 (108)		139 (64)
CHHM1-6145DBY-EP		11.81 (300)	-		23.78 (604)			131 (60)	26.28 (668)						141 (64)
CHHM1H-6145Y-EP		10.51 (267)	-		22.36 (568)			136 (62)	25.10 (638)						148 (67)
CHHM1H-6145DBY-EP	1.5 x 4 (1.1 x 4)	11.81 (300)	-		24.84 (631)			139 (63)	27.58 (701)						150 (68)
CHHM2-6145Y-EP		10.51 (267)	-	6.16 (156)	22.36 (568)			139 (64)	25.10 (638)	6.56 (167)	ø6.57 (ø167)	5.04 (128)	4.61 (117)		151 (69)
CHHM2-6145DBY-EP	2 x 4 (1.5 x 4)	11.81 (300)	-		24.84 (631)			141 (64)	27.58 (701)						153 (70)
CHHM2-6145DCY-EP		11.81 (300)	-		25.39 (645)			144 (66)	28.13 (715)						155 (71)
CHHM3-6145Y-EP		10.83 (275)	-		21.77 (553)			151 (69)	24.84 (631)						168 (76)
CHHM3-6145DBY-EP	3 x 4 (2.2 x 4)	11.81 (300)	-	6.71 (170)	25.67 (652)	4.53 (115)		157 (72)	28.74 (730)	7.60 (193)	ø7.24 (ø184)	5.43 (138)	5.04 (128)		174 (79)
CHHM3-6145DCY-EP		11.81 (300)	-		26.22 (666)			160 (73)	29.29 (744)						177 (80)
CHHM5-6145Y-EP	5 x 4 (3.7 x 4)	11.93 (303)	-	7.34 (186)	23.03 (585)	4.65 (118)		175 (80)	26.59 (676)	8.21 (209)	ø8.74 (ø222)	6.02 (153)	6.30 (160)		199 (91)
CHHM8-6145Y-EP	7.5 x 4 (5.5 x 4)	11.93 (303)	-		24.72 (628)			209 (95)	28.29 (719)						233 (106)
CHHM10-6145Y-EP	10 x 4 (7.5 x 4)	12.68 (322)	-		26.22 (666)			236 (107)	30.35 (771)						280 (127)
CHHM15-6145Y-EP	15 x 4 (11 x 4)	12.68 (322)	-	9.04 (230)	28.66 (728)	5.43 (138)		249 (113)	32.80 (833)	9.57 (243)	ø10.24 (ø260)	7.44 (189)	7.32 (186)		293 (133)
CHHM20-6145Y-EP	20 x 4 (15 x 4)	12.48 (317)	-	10.26 (261)	31.10 (790)	7.01 (178)	ø12.49 (ø317)	329 (150)	36.40 (925)	12.30 (313)	ø12.61 (ø320)	9.53 (242)	-		415 (189)
CHHM1H-614HY-EP	1.5 x 4 (1.1 x 4)	10.91 (277)	-	6.16 (156)	22.36 (568)	3.82 (97)		141 (64)	25.10 (638)	6.56 (167)	ø6.57 (ø167)	5.04 (128)	4.61 (117)		152 (69)
CHHM2-614HY-EP	2 x 4 (1.5 x 4)	10.91 (277)	-					144 (66)							155 (71)
CHHM3-614HY-EP	3 x 4 (2.2 x 4)	11.22 (285)	-	6.71 (170)	21.77 (553)	4.53 (115)		155 (71)	24.84 (631)	7.60 (193)	ø7.24 (ø184)	5.43 (138)	5.04 (128)		172 (78)
CHHM5-614HY-EP	5 x 4 (3.7 x 4)	12.32 (313)	-	7.34 (186)	23.03 (585)	4.65 (118)		180 (82)	26.59 (676)	8.21 (209)	ø8.74 (ø222)	6.02 (153)	6.30 (160)		203 (93)
CHHM8-614HY-EP	7.5 x 4 (5.5 x 4)	12.32 (313)	-		24.72 (628)			214 (97)	28.29 (719)						238 (108)
CHHM10-614HY-EP	10 x 4 (7.5 x 4)	13.07 (332)	-		26.22 (666)			240 (109)	30.35 (771)						285 (129)
CHHM15-614HY-EP	15 x 4 (11 x 4)	13.07 (332)	-	9.04 (230)	28.66 (728)	5.43 (138)		253 (115)	32.80 (833)	9.57 (243)	ø10.24 (ø260)	7.44 (189)	7.32 (186)		297 (135)
CHHM20-614HY-EP	20 x 4 (15 x 4)	12.87 (327)	-	10.26 (261)	31.10 (790)	7.01 (178)	ø12.49 (ø317)	334 (152)	36.40 (925)	12.30 (313)	ø12.61 (ø320)	9.53 (242)	-		420 (191)

Note: [1] MP Dimension Symbol ø = Round Fan Cover
MP Dimension Symbol □ = Square Fan Cover

Dimensions Integral Horizontal Foot Mount

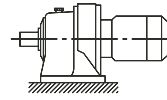

CHHM05-6165DCY ▶ CHHM30-616HY-EP

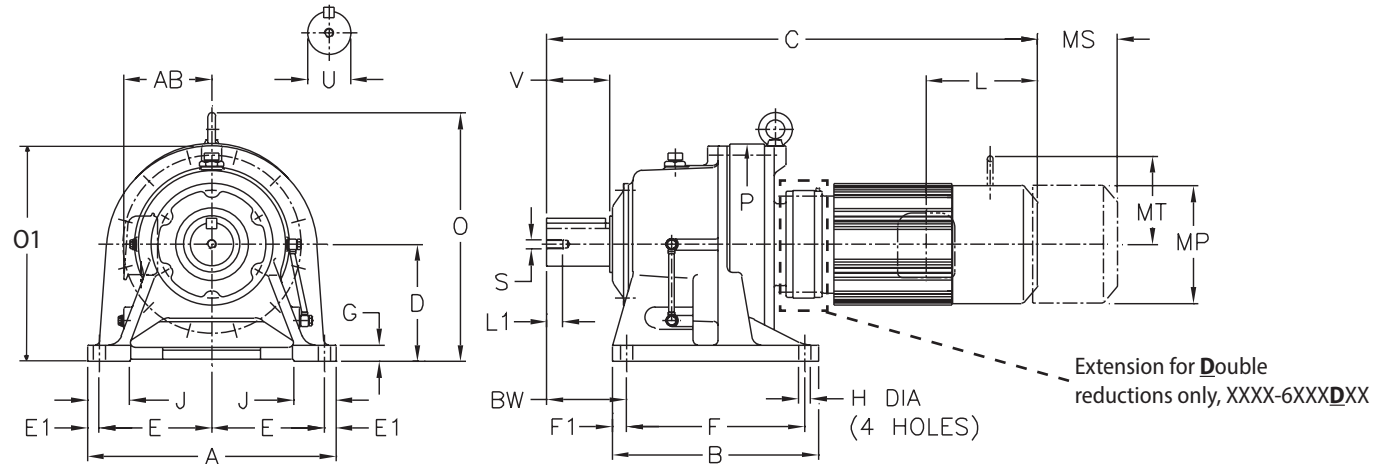

Table 1: Shaft Tolerances All dimensions are in inches (mm)

Low Speed Shaft Nominal Diameter	Tolerance Inches
0.500 through 0.625 (12.700 through 15.875)	+0.0000 / -0.0004 (+0.000 / -0.011)
0.750 through 1.125 (19.050 through 28.757)	+0.0000 / -0.0005 (+0.000 / -0.013)
1.250 through 1.875 (31.750 through 47.625)	+0.0000 / -0.0006 (+0.000 / -0.016)
2.000 through 3.125 (50.800 through 79.375)	+0.0000 / -0.0007 (+0.000 / -0.019)
3.250 through 4.625 (82.550 through 117.475)	+0.0000 / -0.0009 (+0.000 / -0.022)
4.750 through 7.000 (120.650 through 177.800)	+0.0000 / -0.0010 (+0.000 / -0.025)

Note: CHHM units are oil lubricated standard, must be installed as shown above.

Dimensions are in inches (mm)

Model	A	B	D	E	E1	F	F1	G	H	J	P	BW
6160Y 6165Y	16.14 (410)	9.37 (238)	6.299 (160)	7.28 (185)	0.79 (20)	5.91 (150)	1.73 (44)	0.98 (25)	0.71 (18)	2.95 (75)	11.81 (300)	5.47 (139)
616HY	16.14 (410)	9.37 (238)	7.874 (200)	7.28 (185)	0.79 (20)	5.91 (150)	1.73 (44)	0.98 (25)	0.71 (18)	3.15 (80)	11.81 (300)	5.47 (139)

All dimensions are in inches (mm)

Model	Low Speed Shaft				
	U ^[A]	V	S	L1	Key
6160Y 6165Y	2.25 (57.15)	3.54 (90)	3/8-16UNC	0.79 (20)	1/2 x 1/2 x 2.95 (12.7 x 12.7 x 75)
616HY	2.25 (57.15)	3.54 (90)	3/8-16UNC	0.79 (20)	1/2 x 1/2 x 2.95 (12.7 x 12.7 x 75)

Note: [A] Toleranced dimension, please refer to Table 1 above.

Dimensions Integral Horizontal Foot Mount

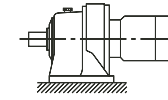

CHHM05-6165DCY ▶ CHHM30-616HY-EP

XXXX-6XX0/6XX5 Frame sizes have equal dimensions, different ratings.

All dimensions are in inches (mm), lbs (kg)

Model	HP x P (kW x P)	O	O1	AB	Without Brake				With Brake					
					C	ML	MP ^[1]	Weight lb (kg)	C	ML	MP ^[1]	MS	MT	Weight lb (kg)
CHHM05-6165DCY	1/2 x 4 (0.4 x 4)	-	-	4.63 (118)	23.23 (590)	2.32 (59)	ø4.88 (ø124)	221 (100)	24.49 (622)	3.58 (91)	ø4.88 (ø124)	2.40 (61)	-	224 (102)
CHHM05-6165DCY-AV		13.74 (349)	-	5.67 (144)	24.65 (626)	3.82 (97)	ø5.94 (ø151)	228 (104) 225 (102)	26.34 (669)	5.51 (140)	ø5.94 (ø151)	3.66 (93)	3.94 (100)	234 (106) 231 (105)
CHHM08-6165DCY	3/4 x 4 (0.55 x 4)	-	-	5.86 (149)	25.94 (659)	3.94 (100)	ø6.30 (ø160)	234 (106)	28.39 (721)	6.38 (162)	ø6.30 (ø160)	4.53 (115)	4.29 (109)	244 (111)
CHHM8-6165DCY-AV		13.74 (349)	-	5.98 (152)	26.38 (670)		ø6.22 (ø158)	238 (108)	28.88 (734)	6.32 (161)	ø6.22 (ø158)	4.80 (122)	4.25 (108)	248 (113)
CHHM11-6165DCY-EP	1 x 4 (0.75 x 4)	-	12.20 (310)		24.25 (616)		ø6.57 (ø167)	219 (99)	26.99 (686)		ø6.57 (ø167)	5.04 (128)	4.61 (117)	230 (105)
CHHM1H-6165Y-EP	1.5 x 4 (1.1 x 4)	13.74 (349)	-	6.16 (156)	27.44 (697)	3.82 (97)	ø6.57 (ø167)	245 (112)	30.18 (767)	6.56 (167)	ø6.57 (ø167)	5.04 (128)	4.61 (117)	257 (117)
CHHM1H-6165DCY-EP		13.74 (349)	-	6.16 (156)	24.25 (616)		ø6.57 (ø167)	222 (101)	26.99 (686)		ø6.57 (ø167)	5.04 (128)	4.61 (117)	233 (106)
CHHM2-6165Y-EP	2 x 4 (1.5 x 4)	-	12.20 (310)		27.44 (697)		ø6.57 (ø167)	248 (113)	30.18 (767)		ø6.57 (ø167)	5.04 (128)	4.61 (117)	260 (118)
CHHM2-6165DCY-EP		13.74 (349)	-	6.71 (170)	26.85 (682)	4.53 (115)	ø7.24 (ø184)	261 (119)	29.92 (760)	7.60 (193)	ø7.24 (ø184)	5.43 (138)	5.04 (128)	278 (126)
CHHM3-6165Y-EP	3 x 4 (2.2 x 4)	-	12.20 (310)		23.66 (601)		ø7.24 (ø184)	232 (105)	26.73 (679)		ø7.24 (ø184)	5.43 (138)	5.04 (128)	248 (113)
CHHM3-6165DCY-EP		13.74 (349)	-	6.71 (170)	26.85 (682)	4.53 (115)	ø7.24 (ø184)	261 (119)	29.92 (760)	7.60 (193)	ø7.24 (ø184)	5.43 (138)	5.04 (128)	278 (126)
CHHM5-6165Y-EP	5 x 4 (3.7 x 4)	12.32 (313)	-	7.34 (186)	25.12 (638)	4.65 (118)	ø8.74 (ø222)	257 (117)	28.68 (729)	8.21 (209)	ø8.74 (ø222)	6.02 (153)	6.30 (160)	280 (127)
CHHM5-6165DCY-EP		13.74 (349)	-	7.34 (186)	28.31 (719)	4.65 (118)	ø8.74 (ø222)	287 (130)	31.87 (810)	8.21 (209)	ø8.74 (ø222)	6.02 (153)	6.30 (160)	311 (141)
CHHM8-6165Y-EP	7.5 x 4 (5.5 x 4)	12.32 (313)	-	7.34 (186)	26.81 (681)	4.65 (118)	ø8.74 (ø222)	291 (132)	30.37 (772)	8.21 (209)	ø8.74 (ø222)	6.02 (153)	6.30 (160)	314 (143)
CHHM8-6165DCY-EP		13.74 (349)	-	7.34 (186)	30.00 (762)	4.65 (118)	ø8.74 (ø222)	321 (146)	33.56 (853)	8.21 (209)	ø8.74 (ø222)	6.02 (153)	6.30 (160)	345 (157)
CHHM10-6165Y-EP	10 x 4 (7.5 x 4)	14.88 (378)	-	9.04 (230)	28.27 (718)	5.43 (138)	ø10.24 (ø260)	318 (145)	32.40 (823)	9.57 (243)	ø10.24 (ø260)	7.44 (189)	7.32 (186)	363 (165)
CHHM15-6165Y-EP	15 x 4 (11 x 4)	14.88 (378)	-	9.04 (230)	30.71 (780)	5.43 (138)	ø10.24 (ø260)	331 (150)	34.84 (885)	9.57 (243)	ø10.24 (ø260)	7.44 (189)	7.32 (186)	375 (170)
CHHM20-6165Y-EP	20 x 4 (15 x 4)	15.24 (387)	-	10.26 (261)	32.99 (838)	7.01 (178)	ø12.49 (ø317)	414 (188)	38.29 (973)	12.30 (313)	ø12.61 (ø320)	9.53 (242)	-	500 (227)
CHHM25-6165Y-EP	25 x 4 (18.5 x 4)	14.72 (374)	-	13.39 (340)	37.17 (944)	9.06 (230)	ø15.12 (ø384)	692 (314)	44.02 (1118)	15.91 (404)	ø15.28 (ø388)	12.13 (308)	-	789 (358)
CHHM30-6165Y-EP	30 x 4 (22 x 4)	14.72 (374)	-	13.39 (340)	37.17 (944)	9.06 (230)	ø15.12 (ø384)	692 (314)	44.02 (1118)	15.91 (404)	ø15.28 (ø388)	12.13 (308)	-	789 (358)

CHHM1H-616HY-EP	1.5 x 4 (1.1 x 4)	-	13.78 (350)	6.16 (156)	24.25 (616)	3.82 (97)	ø6.57 (ø167)	230 (104)	26.99 (686)	6.56 (167)	ø6.57 (ø167)	5.04 (128)	4.61 (117)	241 (110)
CHHM2-616HY-EP	2 x 4 (1.5 x 4)	-	13.78 (350)	6.16 (156)	24.25 (616)	3.82 (97)	ø6.57 (ø167)	233 (106)	26.99 (686)	6.56 (167)	ø6.57 (ø167)	5.04 (128)	4.61 (117)	244 (111)
CHHM3-616HY-EP	3 x 4 (2.2 x 4)	-	13.78 (350)	6.71 (170)	23.66 (601)	4.53 (115)	ø7.24 (ø184)	243 (110)	26.73 (679)	7.60 (193)	ø7.24 (ø184)	5.43 (138)	5.04 (128)	260 (118)
CHHM5-616HY-EP	5 x 4 (3.7 x 4)	13.90 (353)	-	7.34 (186)	25.12 (638)	4.65 (118)	ø8.74 (ø222)	268 (122)	28.68 (729)	8.21 (209)	ø8.74 (ø222)	6.02 (153)	6.30 (160)	291 (132)
CHHM8-616HY-EP	7.5 x 4 (5.5 x 4)	13.90 (353)	-	7.34 (186)	26.81 (681)	4.65 (118)	ø8.74 (ø222)	302 (137)	30.37 (772)	8.21 (209)	ø8.74 (ø222)	6.02 (153)	6.30 (160)	325 (148)
CHHM10-616HY-EP	10 x 4 (7.5 x 4)	16.46 (418)	-	9.04 (230)	28.27 (718)	5.43 (138)	ø10.24 (ø260)	329 (150)	32.40 (823)	9.57 (243)	ø10.24 (ø260)	7.44 (189)	7.32 (186)	374 (170)
CHHM15-616HY-EP	15 x 4 (11 x 4)	16.46 (418)	-	9.04 (230)	30.71 (780)	5.43 (138)	ø10.24 (ø260)	342 (155)	34.84 (885)	9.57 (243)	ø10.24 (ø260)	7.44 (189)	7.32 (186)	386 (175)
CHHM20-616HY-EP	20 x 4 (15 x 4)	16.81 (427)	-	10.26 (261)	32.99 (838)	7.01 (178)	ø12.49 (ø317)	425 (193)	38.29 (973)	12.30 (313)	ø12.61 (ø320)	9.53 (242)	-	511 (232)
CHHM25-616HY-EP	25 x 4 (18.5 x 4)	16.30 (414)	-	13.39 (340)	37.17 (944)	9.06 (230)	ø15.12 (ø384)	703 (319)	44.02 (1118)	15.91 (404)	ø15.28 (ø388)	12.13 (308)	-	800 (363)
CHHM30-616HY-EP	30 x 4 (22 x 4)	16.30 (414)	-	13.39 (340)	37.17 (944)	9.06 (230)	ø15.12 (ø384)	703 (319)	44.02 (1118)	15.91 (404)	ø15.28 (ø388)	12.13 (308)	-	800 (363)

Note: [1] MP Dimension Symbol ø = Round Fan Cover
MP Dimension Symbol □ = Square Fan Cover

Dimensions Integral Horizontal Foot Mount

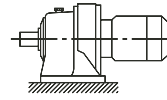

CHHM05-6175DCY ▶ CHHM40-6175Y-EP

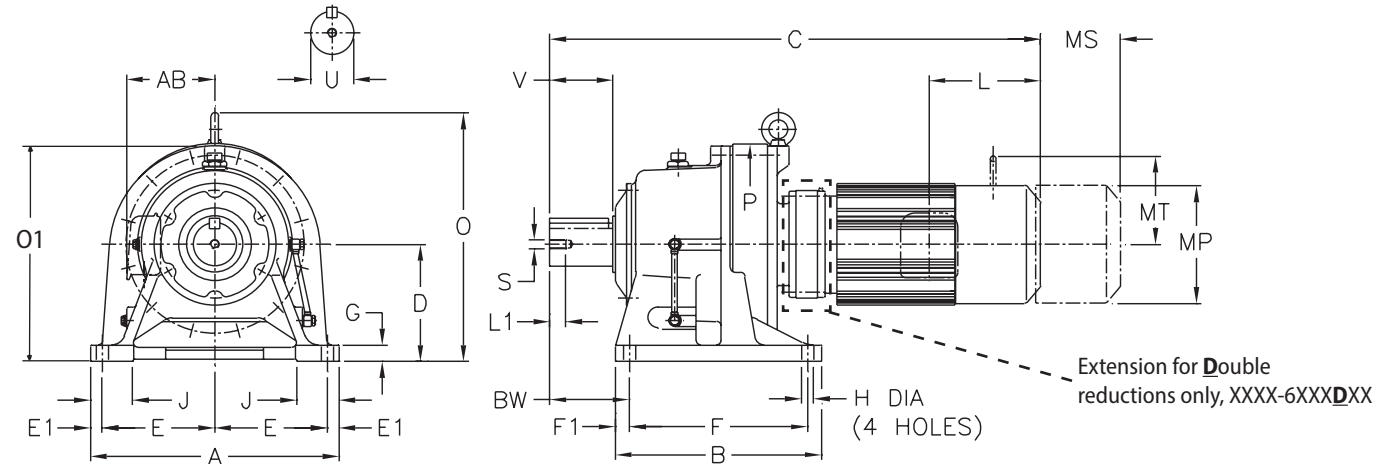

Table 1: Shaft Tolerances All dimensions are in inches (mm)

Low Speed Shaft Nominal Diameter	Tolerance Inches
0.500 through 0.625 (12.700 through 15.875)	+0.0000 / -0.0004 (+0.000 / -0.011)
0.750 through 1.125 (19.050 through 28.757)	+0.0000 / -0.0005 (+0.000 / -0.013)
1.250 through 1.875 (31.750 through 47.625)	+0.0000 / -0.0006 (+0.000 / -0.016)
2.000 through 3.125 (50.800 through 79.375)	+0.0000 / -0.0007 (+0.000 / -0.019)
3.250 through 4.625 (82.550 through 117.475)	+0.0000 / -0.0009 (+0.000 / -0.022)
4.750 through 7.000 (120.650 through 177.800)	+0.0000 / -0.0010 (+0.000 / -0.025)

Note: CHHM units are oil lubricated standard, must be installed as shown above.

Dimensions are in inches (mm)

Model	A	B	D	E	E1	F	F1	G	H	J	P	BW
6170Y	16.93	13.19	7.874	7.48	0.98	10.83	1.18	1.18	0.87	3.15	13.39	4.92
6175Y	(430)	(335)	(200)	(190)	(25)	(275)	(30)	(30)	(22)	(80)	(340)	(125)

All dimensions are in inches (mm)

Model	Low Speed Shaft				Key
	U ^[A]	V	S	L1	
6170Y	2.75	3.54	1/2-13UNC	0.94	5/8 x 5/8 x 3.15
6175Y	(69.85)	(90)		(24)	(15.87 x 15.87 x 80)

Note: [A] Toleranced dimension, please refer to Table 1 above.

Dimensions Integral Horizontal Foot Mount

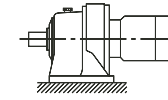

CHHM05-6175DCY ▶ CHHM40-6175Y-EP

XXXX-6XX0/6XX5 Frame sizes have equal dimensions, different ratings.

All dimensions are in inches (mm), lbs (kg)

Model	HP x P (kW x P)	O	O1	AB	Without Brake				With Brake					
					C	ML	MP ^[1]	Weight lb (kg)	C	ML	MP ^[1]	MS	MT	Weight lb (kg)
CHHM05-6175DCY	1/2 x 4 (0.4 x 4)	-	-	4.63 (118)	25.08 (637)	2.32 (59)	ø4.88 (ø124)	296 (134)	26.34 (669)	3.58 (91)	ø4.88 (ø124)	2.40 (61)	-	299 (136)
CHHM05-6175DCY-AV		16.38 (416)	-	5.67 (144)	26.50 (673)	3.82 (97)	ø5.94 (ø151)	303 (138)	28.19 (716)	5.51 (140)	ø5.94 (ø151)	3.66 (93)	3.94 (100)	309 (140)
CHHM08-6175DCY	3/4 x 4 (0.55 x 4)	-	-	5.86 (149)	27.80 (706)	3.94 (100)	ø6.30 (ø160)	300 (136)	30.24 (768)	6.38 (162)	ø6.30 (ø160)	4.53 (115)	4.29 (109)	319 (145)
CHHM8-6175DCY-AV		16.38 (416)	-	5.98 (152)	27.52 (699)		ø6.22 (ø158)	309 (140)	30.02 (763)	6.32 (161)	ø6.22 (ø158)	4.80 (122)	4.25 (108)	319 (145)
CHHM1-6175DAY-EP	1 x 4 (0.75 x 4)	16.38 (416)	-	5.98 (152)	28.23 (717)		ø6.22 (ø158)	313 (142)	30.73 (781)	6.32 (161)	ø6.22 (ø158)	4.80 (122)	4.25 (108)	323 (147)
CHHM1-6175DCY-EP		16.38 (416)	-	6.16 (156)	29.29 (744)		ø6.57 (ø167)	320 (146)	32.03 (814)	6.56 (167)	ø6.57 (ø167)	5.04 (128)	4.61 (117)	332 (151)
CHHM2-6175DAY-EP	2 x 4 (1.5 x 4)	16.38 (416)	-	6.16 (156)	28.58 (726)		ø6.57 (ø167)	309 (140)	31.32 (796)	6.56 (167)	ø6.57 (ø167)	5.04 (128)	4.61 (117)	321 (146)
CHHM2-6175DCY-EP		16.38 (416)	-	6.71 (170)	29.29 (744)		ø7.24 (ø184)	323 (147)	32.03 (814)	7.60 (193)	ø7.24 (ø184)	5.43 (138)	5.04 (128)	335 (152)
CHHM3-6175DCY-EP	3 x 4 (2.2 x 4)	16.38 (416)	-	6.71 (170)	28.70 (729)	4.53 (115)	ø7.24 (ø184)	336 (153)	31.77 (807)	7.60 (193)	ø7.24 (ø184)	5.43 (138)	5.04 (128)	353 (160)
CHHM5-6175Y-EP	5 x 4 (3.7 x 4)	16.10 (409)	-	7.34 (186)	27.05 (687)		ø8.74 (ø222)	351 (159)	30.61 (778)	8.21 (209)	ø8.74 (ø222)	6.02 (153)	6.30 (160)	375 (170)
CHHM5-6175DCY-EP		16.38 (416)	-	7.34 (186)	30.16 (766)	4.65 (118)	ø8.74 (ø222)	362 (164)	33.72 (857)	8.21 (209)	ø8.74 (ø222)	6.02 (153)	6.30 (160)	386 (175)
CHHM8-6175Y-EP	7.5 x 4 (5.5 x 4)	16.10 (409)	-	7.34 (186)	28.74 (730)		ø8.74 (ø222)	385 (175)	32.30 (821)	8.21 (209)	ø8.74 (ø222)	6.02 (153)	6.30 (160)	408 (186)
CHHM8-6175DCY-EP		16.38 (416)	-	9.04 (230)	31.85 (809)		ø10.24 (ø260)	396 (180)	35.41 (900)	9.57 (243)	ø10.24 (ø260)	7.44 (189)	7.32 (186)	419 (191)
CHHM10-6175Y-EP	10 x 4 (7.5 x 4)	16.57 (421)	-	9.04 (230)	29.57 (751)	5.43 (138)	ø10.24 (ø260)	413 (188)	33.70 (856)	9.57 (243)	ø10.24 (ø260)	7.44 (189)	7.32 (186)	458 (208)
CHHM15-6175Y-EP	15 x 4 (11 x 4)	16.57 (421)	-	9.04 (230)	32.01 (813)		ø12.49 (ø317)	426 (194)	36.14 (918)	9.57 (243)	ø12.49 (ø317)	7.44 (189)	7.32 (186)	470 (214)
CHHM20-6175Y-EP	20 x 4 (15 x 4)	16.69 (424)	-	10.26 (261)	34.72 (882)	7.01 (178)	ø12.49 (ø317)	507 (230)	40.02 (1017)	12.30 (313)	ø12.61 (ø320)	9.53 (242)	-	593 (269)
CHHM25-6175Y-EP	25 x 4 (18.5 x 4)	16.69 (424)	-	13.39 (340)	38.90 (988)	9.06 (230)	ø15.12 (ø384)	786 (357)	45.75 (1162)	15.91 (404)	ø15.28 (ø388)	12.13 (308)	-	883 (401)
CHHM30-6175Y-EP	30 x 4 (22 x 4)	16.69 (424)	-	13.39 (340)	43.78 (1112)		ø15.12 (ø384)	786 (357)	50.63 (1286)	15.91 (404)	ø15.28 (ø388)	12.13 (308)	-	883 (401)
CHHM40-6175Y-EP	40 x 4 (30 x 4)	16.69 (424)	-	13.39 (340)	43.78 (1112)		ø15.12 (ø384)	899 (408)	50.63 (1286)	15.91 (404)	ø15.28 (ø388)	12.13 (308)	-	996 (452)

Note: [1] MP Dimension Symbol ø = Round Fan Cover
MP Dimension Symbol □ = Square Fan Cover

Dimensions Integral Horizontal Foot Mount

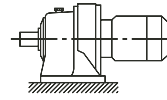

CHHM1-6185DBY-EP ▶ CHHM50-6185Y-EP

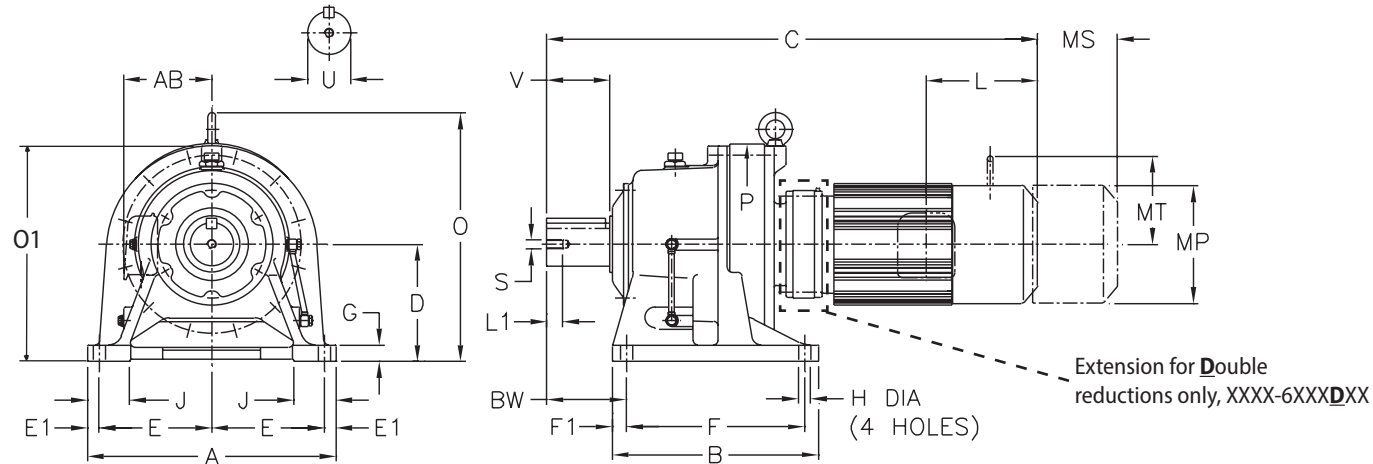

Table 1: Shaft Tolerances All dimensions are in inches (mm)

Low Speed Shaft Nominal Diameter	Tolerance Inches
0.500 through 0.625 (12.700 through 15.875)	+0.0000 / -0.0004 (+0.000 / -0.011)
0.750 through 1.125 (19.050 through 28.757)	+0.0000 / -0.0005 (+0.000 / -0.013)
1.250 through 1.875 (31.750 through 47.625)	+0.0000 / -0.0006 (+0.000 / -0.016)
2.000 through 3.125 (50.800 through 79.375)	+0.0000 / -0.0007 (+0.000 / -0.019)
3.250 through 4.625 (82.550 through 117.475)	+0.0000 / -0.0009 (+0.000 / -0.022)
4.750 through 7.000 (120.650 through 177.800)	+0.0000 / -0.0010 (+0.000 / -0.025)

Note: CHHM units are oil lubricated standard, must be installed as shown above.

Dimensions are in inches (mm)

Model	A	B	D	E	E1	F	F1	G	H	J	P	BW
6180Y	18.50	14.96	8.661	8.27	0.98	12.60	1.18	1.18	0.87	3.35	14.57	5.71
6185Y	(470)	(380)	(220)	(210)	(25)	(320)	(30)	(30)	(22)	(85)	(370)	(145)

All dimensions are in inches (mm)

Model	Low Speed Shaft				Key
	U ^[A]	V	S	L1	
6180Y	3.13	4.33	1/2-13UNC	0.94	3/4 x 3/4 x 3.74
6185Y	(79.375)	(110)		(24)	(19.05 x 19.05 x 95)

Note: [A] Toleranced dimension, please refer to Table 1 above.

Dimensions Integral Horizontal Foot Mount

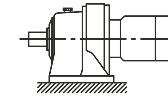

CHHM1-6185DBY-EP ▶ CHHM50-6185Y-EP

XXXX-6XX0/6XX5 Frame sizes have equal dimensions, different ratings.

All dimensions are in inches (mm), lbs (kg)

Model	HP x P (kW x P)	O	O1	AB	Without Brake				With Brake					
					C	ML	MP ^[1]	Weight lb (kg)	C	ML	MP ^[1]	MS	MT	Weight lb (kg)
CHHM1-6185DBY-EP	1 x 4 (0.75 x 4)	17.76 (451)	-	5.98 (152)	30.59 (777)	3.82 (97)	□6.22 (□158)	436 (198)	33.09 (841)	6.32 (161)	□6.22 (□158)	4.80 (122)	4.25 (108)	446 (203)
CHHM1H-6185DBY-EP	1.5 x 4 (1.1 x 4)	17.76 (451)	-		31.65 (804)		443 (201)	34.39 (874)						454 (206)
CHHM2-6185DAY-EP	2 x 4 (1.5 x 4)	17.76 (451)	-	6.16 (156)	30.79 (782)		406 (185)	33.52 (852)	6.56 (167)	□6.57 (□167)	5.04 (128)	4.61 (117)		418 (190)
CHHM2-6185DBY-EP		17.76 (451)	-		31.65 (804)	446 (203)	34.39 (874)						457 (208)	
CHHM3-6185DBY-EP	3 x 4 (2.2 x 4)	17.76 (451)	-	6.71 (170)	31.06 (789)	453 (115)	□7.24 (□184)	457 (208)	34.13 (867)	7.60 (193)	□7.24 (□184)	5.43 (138)	5.04 (128)	474 (215)
CHHM5-6185Y-EP	5 x 4 (3.7 x 4)	17.48 (444)	-		28.50 (724)	4.65 (118)	□8.74 (□222)	431 (196)	32.07 (815)	8.21 (209)	□8.74 (□222)	6.02 (153)	6.30 (160)	455 (207)
CHHM5-6185DBY-EP		17.76 (451)	-	7.34 (186)	32.32 (821)			482 (219)	35.89 (912)					505 (230)
CHHM8-6185Y-EP	7.5 x 4 (5.5 x 4)	17.48 (444)	-		30.20 (767)			465 (211)	33.76 (858)					489 (222)
CHHM8-6185DBY-EP		17.76 (451)	-		34.02 (864)	516 (234)	37.58 (955)	540 (245)						
CHHM10-6185Y-EP	10 x 4 (7.5 x 4)	17.91 (455)	-		31.14 (791)	5.43 (138)	□10.24 (□260)	496 (225)	35.28 (896)	9.57 (243)	□10.24 (□260)	7.44 (189)	7.32 (186)	540 (245)
CHHM10-6185DBY-EP		17.76 (451)	-	9.04 (230)	35.51 (902)			543 (246)	39.65 (1007)					587 (266)
CHHM15-6185Y-EP	15 x 4 (11 x 4)	17.91 (455)	-		33.58 (853)			508 (231)	37.72 (958)					553 (251)
CHHM15-6185DBY-EP		17.76 (451)	-		37.95 (964)	555 (252)	42.09 (1069)	599 (272)						
CHHM20-6185Y-EP	20 x 4 (15 x 4)	17.83 (453)	-	10.26 (261)	36.18 (919)	7.01 (178)	∅12.49 (∅317)	588 (267)	41.48 (1054)	12.30 (313)	∅12.61 (∅320)	9.53 (242)		674 (306)
CHHM25-6185Y-EP	25 x 4 (18.5 x 4)	17.87 (454)	-		40.35 (1025)	9.06 (230)	∅15.12 (∅384)	865 (393)	47.20 (1199)	15.91 (404)	∅15.28 (∅388)	12.13 (308)		962 (437)
CHHM30-6185Y-EP	30 x 4 (22 x 4)	17.87 (454)	-	13.39 (340)	40.35 (1025)			865 (393)	52.09 (1323)				962 (437)	
CHHM40-6185Y-EP	40 x 4 (30 x 4)	17.87 (454)	-		45.24 (1149)			978 (444)					1075 (488)	
CHHM50-6185Y-EP	50 x 4 (37 x 4)	17.87 (454)	-					1047 (475)						-

Note: [1] MP Dimension Symbol ∅ = Round Fan Cover
MP Dimension Symbol □ = Square Fan Cover

Dimensions Integral Horizontal Foot Mount

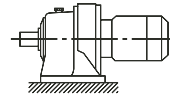

CHHM1-6195DAY-EP ▶ CHHM60-6195Y-EP

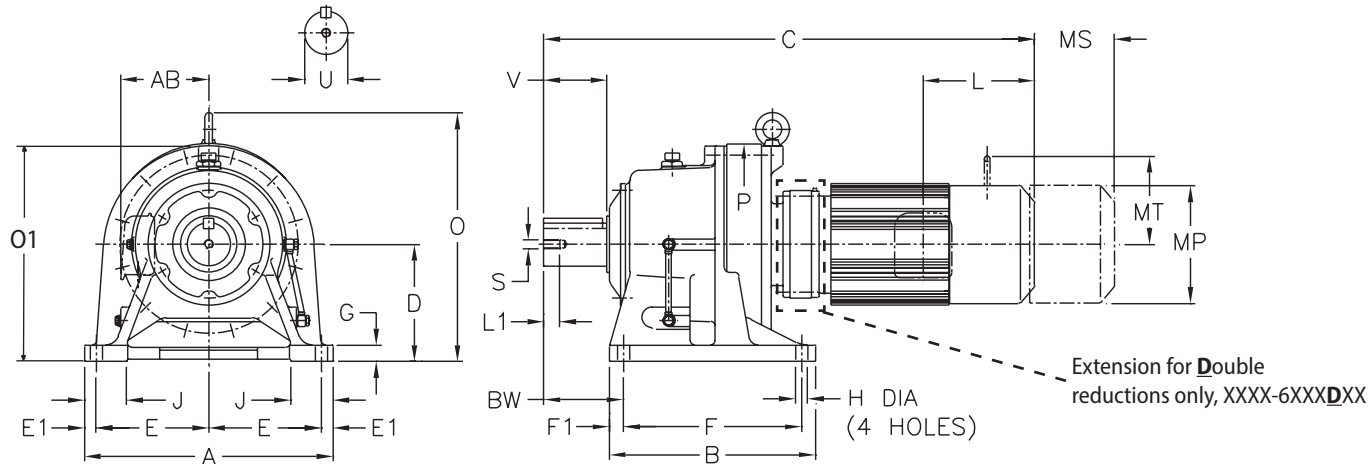

Table 1: Shaft Tolerances All dimensions are in inches (mm)

Low Speed Shaft Nominal Diameter	Tolerance Inches
0.500 through 0.625 (12.700 through 15.875)	+0.0000 / -0.0004 (+0.000 / -0.011)
0.750 through 1.125 (19.050 through 28.757)	+0.0000 / -0.0005 (+0.000 / -0.013)
1.250 through 1.875 (31.750 through 47.625)	+0.0000 / -0.0006 (+0.000 / -0.016)
2.000 through 3.125 (50.800 through 79.375)	+0.0000 / -0.0007 (+0.000 / -0.019)
3.250 through 4.625 (82.550 through 117.475)	+0.0000 / -0.0009 (+0.000 / -0.022)
4.750 through 7.000 (120.650 through 177.800)	+0.0000 / -0.0010 (+0.000 / -0.025)

Note: CHHM units are oil lubricated standard, must be installed as shown above.

Dimensions are in inches (mm)

Model	A	B	D	E	E1	F	F1	G	H	J	P	BW
6190Y	20.87	17.32	9.843	9.45	0.98	14.96	1.18	1.38	1.02	3.54	16.93	6.69
6195Y	(530)	(440)	(250)	(240)	(25)	(380)	(30)	(35)	(26)	(90)	(430)	(170)

All dimensions are in inches (mm)

Model	Low Speed Shaft				Key
	U ^[A]	V	S	L1	
6190Y	3.63	5.31	3/4-10UNC	1.34	7/8 x 7/8 x 4.92
6195Y	(92.075)	(135)		(34)	(22.225 x 22.225 x 125)

Note: [A] Toleranced dimension, please refer to Table 1 above.

Dimensions Integral Horizontal Foot Mount

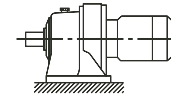

CHHM1-6195DAY-EP ▶ CHHM60-6195Y-EP

XXXX-6XX0/6XX5 Frame sizes have equal dimensions, different ratings.

All dimensions are in inches (mm), lbs (kg)

Model	HP x P (kW x P)	O	O1	AB	Without Brake				With Brake					
					C	ML	MP ^[1]	Weight lb (kg)	C	ML	MP ^[1]	MS	MT	Weight lb (kg)
CHHM1-6195DAY-EP	1 x 4 (0.75 x 4)	20.91 (531)	-	5.98 (152)	32.95 (837)	3.82 (97)	□6.22 (□158)	563 (255)	35.45 (901)	6.32 (161)	□6.22 (□158)	4.80 (122)	4.25 (108)	572 (260)
CHHM1H-6195DAY-EP	1.5 x 4 (1.1 x 4)	20.91 (531)	-	6.16 (156)	34.02 (864)		□6.57 (□167)	569 (259)	36.75 (934)	6.56 (167)	□6.57 (□167)	5.04 (128)	4.61 (117)	581 (264)
CHHM2-6195DAY-EP	2 x 4 (1.5 x 4)	20.91 (531)	-	6.71 (170)	33.43 (849)	4.53 (115)	□7.24 (□184)	572 (260)	36.50 (927)	7.60 (193)	□7.24 (□184)	5.43 (138)	5.04 (128)	584 (265)
CHHM3-6195DAY-EP	3 x 4 (2.2 x 4)	20.91 (531)	-	7.34 (186)	34.06 (865)		□8.74 (□222)	585 (266)	37.13 (943)	8.21 (209)	□8.74 (□222)	6.02 (153)	6.30 (160)	602 (273)
CHHM3-6195DBY-EP	3 x 4 (2.2 x 4)	20.91 (531)	-	7.34 (186)	34.06 (865)	□8.74 (□222)	605 (275)	37.13 (943)	8.21 (209)	□8.74 (□222)	6.02 (153)	6.30 (160)	622 (282)	
CHHM5-6195DAY-EP	5 x 4 (3.7 x 4)	20.91 (531)	-	9.04 (230)	34.88 (886)	5.43 (138)	□10.24 (□260)	611 (277)	38.44 (977)	9.57 (243)	□10.24 (□260)	7.44 (189)	7.32 (186)	635 (288)
CHHM5-6195DBY-EP	5 x 4 (3.7 x 4)	20.91 (531)	-	9.04 (230)	35.31 (897)		□10.24 (□260)	629 (286)	38.88 (988)	9.57 (243)	□10.24 (□260)	7.44 (189)	7.32 (186)	653 (297)
CHHM8-6195Y-EP	7.5 x 4 (5.5 x 4)	19.96 (507)	-	10.26 (261)	33.78 (858)	9.06 (230)	□12.49 (□317)	633 (287)	37.34 (949)	12.30 (313)	□12.61 (□320)	9.53 (242)	-	656 (298)
CHHM8-6195DAY-EP	7.5 x 4 (5.5 x 4)	20.91 (531)	-	10.26 (261)	36.57 (929)		□12.49 (□317)	645 (293)	40.14 (1020)	12.30 (313)	□12.61 (□320)	9.53 (242)	-	669 (304)
CHHM8-6195DBY-EP	7.5 x 4 (5.5 x 4)	20.91 (531)	-	10.26 (261)	37.01 (940)	□12.49 (□317)	663 (301)	40.57 (1031)	12.30 (313)	□12.61 (□320)	9.53 (242)	-	687 (312)	
CHHM10-6195Y-EP	10 x 4 (7.5 x 4)	20.43 (519)	-	13.39 (340)	34.02 (864)	9.06 (230)	□15.12 (□384)	663 (301)	38.15 (969)	15.91 (404)	□15.28 (□388)	12.13 (308)	-	707 (321)
CHHM10-6195DBY-EP	10 x 4 (7.5 x 4)	20.91 (531)	-	13.39 (340)	38.50 (978)		□15.12 (□384)	690 (313)	42.64 (1083)	15.91 (404)	□15.28 (□388)	12.13 (308)	-	735 (333)
CHHM15-6195Y-EP	15 x 4 (11 x 4)	20.43 (519)	-	16.33 (415)	36.46 (926)	9.06 (230)	□18.66 (□474)	676 (307)	40.59 (1031)	-	-	-	-	720 (327)
CHHM15-6195DBY-EP	15 x 4 (11 x 4)	20.91 (531)	-	16.33 (415)	40.94 (1040)		□18.66 (□474)	703 (319)	45.08 (1145)	-	-	-	-	747 (339)
CHHM20-6195Y-EP	20 x 4 (15 x 4)	19.02 (483)	-	16.33 (415)	39.17 (995)	9.06 (230)	□18.66 (□474)	754 (342)	44.47 (1130)	-	-	-	-	840 (381)
CHHM20-6195DBY-EP	20 x 4 (15 x 4)	20.91 (531)	-	16.33 (415)	43.39 (1102)		□18.66 (□474)	783 (356)	48.68 (1237)	-	-	-	-	869 (395)
CHHM25-6195Y-EP	25 x 4 (18.5 x 4)	20.87 (530)	-	16.33 (415)	20.87 (530)	9.06 (230)	□18.66 (□474)	1032 (469)	50.20 (1275)	-	-	-	-	1129 (513)
CHHM30-6195Y-EP	30 x 4 (22 x 4)	20.87 (530)	-	16.33 (415)	20.87 (530)		□18.66 (□474)	1032 (469)	50.20 (1275)	-	-	-	-	1129 (513)
CHHM40-6195Y-EP	40 x 4 (30 x 4)	20.87 (530)	-	16.33 (415)	20.87 (530)	□18.66 (□474)	1145 (520)	55.08 (1399)	-	-	-	-	1242 (564)	
CHHM50-6195Y-EP	50 x 4 (37 x 4)	20.87 (530)	-	16.33 (415)	20.87 (530)	□18.66 (□474)	1214 (551)	-	-	-	-	-	-	
CHHM60-6195Y-EP	60 x 4 (45 x 4)	20.51 (521)	-	16.33 (415)	20.51 (521)	□18.66 (□474)	1342 (609)	-	-	-	-	-	-	

Note: [1] MP Dimension Symbol ϕ = Round Fan Cover
MP Dimension Symbol \square = Square Fan Cover

Dimensions Integral Horizontal Foot Mount

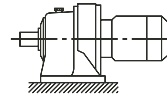

CHHM1-6205DAY-EP ▶ CHHM75-6205Y-EP

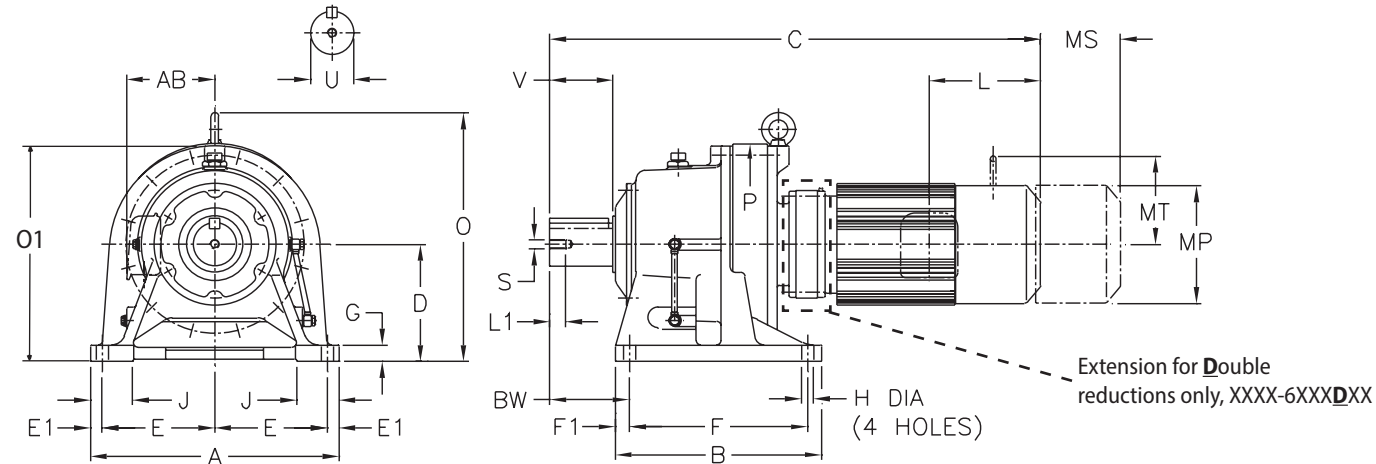

Table 1: Shaft Tolerances All dimensions are in inches (mm)

Low Speed Shaft Nominal Diameter	Tolerance Inches
0.500 through 0.625 (12.700 through 15.875)	+0.0000 / -0.0004 (+0.000 / -0.011)
0.750 through 1.125 (19.050 through 28.757)	+0.0000 / -0.0005 (+0.000 / -0.013)
1.250 through 1.875 (31.750 through 47.625)	+0.0000 / -0.0006 (+0.000 / -0.016)
2.000 through 3.125 (50.800 through 79.375)	+0.0000 / -0.0007 (+0.000 / -0.019)
3.250 through 4.625 (82.550 through 117.475)	+0.0000 / -0.0009 (+0.000 / -0.022)
4.750 through 7.000 (120.650 through 177.800)	+0.0000 / -0.0010 (+0.000 / -0.025)

Note: CHHM units are oil lubricated standard, must be installed as shown above.

Dimensions are in inches (mm)

Model	A	B	D	E	E1	F	F1	G	H	J	P	BW
6205Y	20.87 (530)	17.32 (440)	9.843 (250)	8.66 (220)	1.77 (45)	14.17 (360)	1.57 (40)	1.38 (35)	1.02 (26)	3.94 (100)	17.64 (448)	8.46 (215)

All dimensions are in inches (mm)

Model	Low Speed Shaft				Key
	U ^[A]	V	S	L1	
6205Y	3.88 (98.425)	6.50 (165)	3/4-10UNC	1.34 (34)	1 x 1 x 6.5 (25.4 x 25.4 x 165)

Note: [A] Toleranced dimension, please refer to Table 1 above.

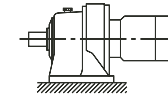

Dimensions Integral Horizontal Foot Mount

CHHM1-6205DAY-EP ▶ CHHM75-6205Y-EP

XXXX-6XX0/6XX5 Frame sizes have equal dimensions, different ratings.

All dimensions are in inches (mm), lbs (kg)

Model	HP x P (kW x P)	O	O1	AB	Without Brake				With Brake					
					C	ML	MP ^[1]	Weight lb (kg)	C	ML	MP ^[1]	MS	MT	Weight lb (kg)
CHHM1-6205DAY-EP	1 x 4 (0.75 x 4)	20.87 (530)	-	5.98 (152)	34.57 (878)	3.82 (97)	□6.22 (□158)	604 (274)	37.07 (942)	6.32 (161)	□6.22 (□158)	4.80 (122)	4.25 (108)	614 (279)
CHHM2-6205DAY-EP	2 x 4 (1.5 x 4)	20.87 (530)	-	6.16 (156)	35.63 (905)		□6.57 (□167)	614 (279)	38.37 (975)	6.56 (167)	□6.57 (□167)	5.04 (128)	4.61 (117)	626 (284)
CHHM3-6205DAY-EP	3 x 4 (2.2 x 4)	20.87 (530)	-	6.71 (170)	35.04 (890)	4.53 (115)	□7.24 (□184)	627 (285)	38.11 (968)	7.60 (193)	□7.24 (□184)	5.43 (138)	5.04 (128)	644 (292)
CHHM3-6205DBY-EP		20.87 (530)	-		36.10 (917)			656 (298)	39.17 (995)					673 (305)
CHHM5-6205DAY-EP	5 x 4 (3.7 x 4)	20.87 (530)	-		36.50 (927)			653 (296)	40.06 (1018)					677 (307)
CHHM5-6205DBY-EP		20.87 (530)	-		37.36 (949)	4.65 (118)	□8.74 (□222)	680 (309)	40.93 (1040)	8.21 (209)	□8.74 (□222)	6.02 (153)	6.30 (160)	704 (320)
CHHM8-6205DAY-EP	7.5 x 4 (5.5 x 4)	20.87 (530)	-	7.34 (186)	38.19 (970)			687 (312)	41.75 (1061)					710 (323)
CHHM8-6205DBY-EP		20.87 (530)	-		39.06 (992)			714 (324)	42.62 (1083)					738 (335)
CHHM10-6205DBY-EP	10 x 4 (7.5 x 4)	20.87 (530)	-		40.55 (1030)			741 (336)	44.69 (1135)					785 (356)
CHHM15-6205Y-EP	15 x 4 (11 x 4)	20.91 (531)	-	9.04 (230)	37.97 (965)	5.43 (138)	□10.24 (□260)	705 (320)	42.11 (1070)	9.57 (243)	□10.24 (□260)	7.44 (189)	7.32 (186)	749 (340)
CHHM15-6205DBY-EP		20.87 (530)	-		42.99 (1092)			754 (342)	47.13 (1197)					798 (362)
CHHM20-6205Y-EP	20 x 4 (15 x 4)	20.87 (530)	-	10.26 (261)	41.02 (1042)	7.01 (178)	ø12.49 (ø317)	794 (360)	46.32 (1177)	12.30 (313)	ø12.61 (ø320)	9.53 (242)		880 (399)
CHHM20-6205DBY-EP		20.87 (530)	-		45.43 (1154)			834 (379)	50.73 (1289)					920 (418)
CHHM25-6205Y-EP	25 x 4 (18.5 x 4)	20.87 (530)	-		44.80 (1138)			1066 (484)	51.65 (1312)					1163 (528)
CHHM30-6205Y-EP	30 x 4 (22 x 4)	20.87 (530)	-	13.39 (340)		9.06 (230)	ø15.12 (ø384)	1066 (484)	51.65 (1312)	15.91 (404)	ø15.28 (ø388)	12.13 (308)		1163 (528)
CHHM40-6205Y-EP	40 x 4 (30 x 4)	20.87 (530)	-		49.69 (1262)			1179 (535)	56.54 (1436)					1276 (579)
CHHM50-6205Y-EP	50 x 4 (37 x 4)	20.87 (530)	-					1248 (566)						-
CHHM60-6205Y-EP	60 x 4 (45 x 4)	20.87 (530)	-	16.33 (415)	51.14 (1299)	16.81 (427)	ø18.66 (ø474)	1381 (627)						-
CHHM75-6205Y-EP	75 x 4 (55 x 4)	20.87 (530)	-					1461 (663)						-

Note: [1] MP Dimension Symbol ø = Round Fan Cover
MP Dimension Symbol □ = Square Fan Cover

Dimensions Integral Horizontal Foot Mount

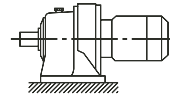

CHHM2-6215DAY-EP ▶ CHHM75-6215Y-EP

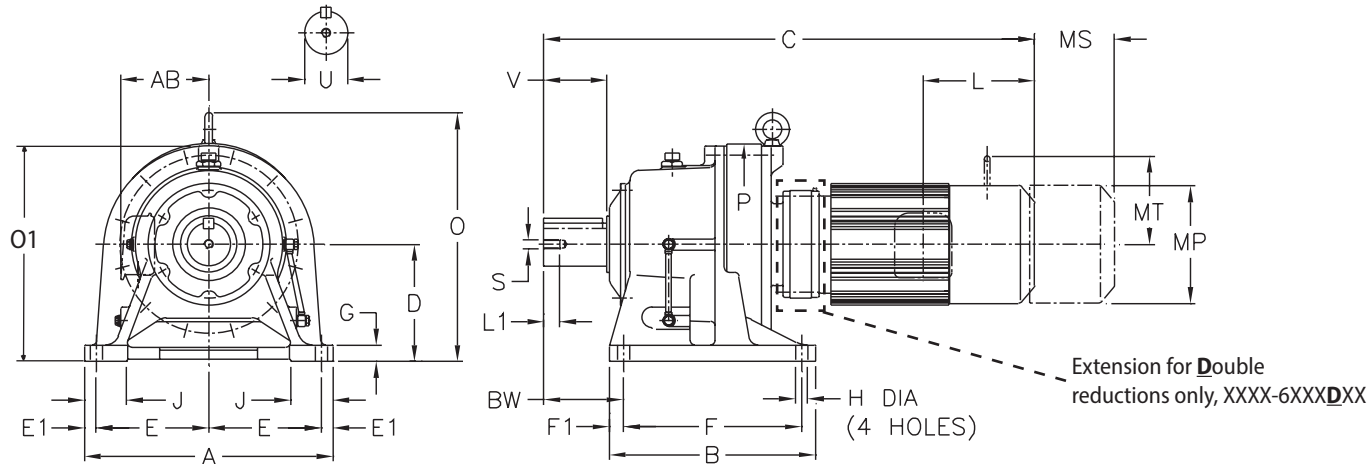

Table 1: Shaft Tolerances All dimensions are in inches (mm)

Low Speed Shaft Nominal Diameter	Tolerance Inches
0.500 through 0.625 (12.700 through 15.875)	+0.0000 / -0.0004 (+0.000 / -0.011)
0.750 through 1.125 (19.050 through 28.757)	+0.0000 / -0.0005 (+0.000 / -0.013)
1.250 through 1.875 (31.750 through 47.625)	+0.0000 / -0.0006 (+0.000 / -0.016)
2.000 through 3.125 (50.800 through 79.375)	+0.0000 / -0.0007 (+0.000 / -0.019)
3.250 through 4.625 (82.550 through 117.475)	+0.0000 / -0.0009 (+0.000 / -0.022)
4.750 through 7.000 (120.650 through 177.800)	+0.0000 / -0.0010 (+0.000 / -0.025)

Note: CHHM units are oil lubricated standard, must be installed as shown above.

Dimensions are in inches (mm)

Model	A	B	D	E	E1	F	F1	G	H	J	P	BW
6215Y	22.83 (580)	18.70 (475)	10.433 (265)	9.45 (240)	1.97 (50)	15.55 (395)	1.57 (40)	1.57 (40)	1.02 (26)	4.33 (110)	19.09 (485)	8.27 (210)

All dimensions are in inches (mm)

Model	Low Speed Shaft				Key
	U ^[A]	V	S	L1	
6215Y	4.25 (107.95)	6.50 (165)	3/4-10UNC	1.34 (34)	1 x 1 x 6.5 (25.4 x 25.4 x 165)

Note: [A] Toleranced dimension, please refer to Table 1 above.

Dimensions Integral Horizontal Foot Mount

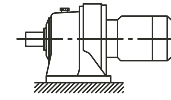

CHHM2-6215DAY-EP ▶ CHHM75-6215Y-EP

XXXX-6XX0/6XX5 Frame sizes have equal dimensions, different ratings.

All dimensions are in inches (mm), lbs (kg)

Model	HP x P (kW x P)	O	O1	AB	Without Brake				With Brake					
					C	ML	MP ^[1]	Weight lb (kg)	C	ML	MP ^[1]	MS	MT	Weight lb (kg)
CHHM2-6215DAY-EP	2 x 4 (1.5 x 4)	22.64 (575)	-	6.16 (156)	37.72 (958)	3.82 (97)	□6.57 (□167)	823 (374)	40.45 (1028)	6.56 (167)	□6.57 (□167)	5.04 (128)	4.61 (117)	834 (379)
CHHM3-6215DAY-EP	3 x 4 (2.2 x 4)	22.64 (575)	-	6.71 (170)	37.13 (943)	4.53 (115)	□7.24 (□184)	834 (379)	40.20 (1021)	7.60 (193)	□7.24 (□184)	5.43 (138)	5.04 (128)	851 (386)
CHHM5-6215DAY-EP	5 x 4 (3.7 x 4)	22.64 (575)	-	7.34 (186)	38.39 (975)	4.65 (118)	□8.74 (□222)	859 (390)	41.95 (1066)	8.21 (209)	□8.74 (□222)	6.02 (153)	6.30 (160)	882 (401)
CHHM5-6215DBY-EP		22.64 (575)	-		39.57 (1005)			900 (409)	43.13 (1096)					924 (419)
CHHM8-6215DAY-EP	7.5 x 4 (5.5 x 4)	22.64 (575)	-	9.04 (230)	40.08 (1018)	5.43 (138)	□10.24 (□260)	893 (405)	43.64 (1109)	9.57 (243)	□10.24 (□260)	7.44 (189)	7.32 (186)	917 (416)
CHHM8-6215DBY-EP		22.64 (575)	-		41.26 (1048)			934 (424)	44.82 (1139)					958 (435)
CHHM10-6215DAY-EP	10 x 4 (7.5 x 4)	22.64 (575)	-	10.26 (261)	41.57 (1056)	7.01 (178)	□12.49 (□317)	920 (417)	45.71 (1161)	12.30 (313)	□12.61 (□320)	9.53 (242)	-	964 (437)
CHHM10-6215DBY-EP		22.64 (575)	-		42.72 (1085)			962 (437)	46.85 (1190)					1006 (457)
CHHM15-6215Y-EP	15 x 4 (11 x 4)	22.64 (575)	-	13.39 (340)	39.29 (998)	9.06 (230)	□15.12 (□384)	895 (406)	43.43 (1103)	15.91 (404)	□15.28 (□388)	12.13 (308)	-	939 (426)
CHHM15-6215DAY-EP		22.64 (575)	-		44.02 (1118)			932 (423)	48.15 (1223)					976 (443)
CHHM15-6215DBY-EP		22.64 (575)	-		45.16 (1147)			975 (442)	49.29 (1252)					1019 (462)
CHHM20-6215Y-EP	20 x 4 (15 x 4)	22.64 (575)	-	16.33 (415)	41.97 (1066)	16.81 (427)	□18.66 (□474)	979 (444)	47.26 (1201)	-	-	-	-	1065 (483)
CHHM20-6215DAY-EP		22.64 (575)	-		46.46 (1180)			1013 (460)	51.75 (1315)					1099 (499)
CHHM20-6215DBY-EP	22.64 (575)	-	47.44 (1205)	1058 (480)	52.74 (1340)	1144 (519)								
CHHM25-6215Y-EP	25 x 4 (18.5 x 4)	22.64 (575)	-	16.33 (415)	45.75 (1162)	16.81 (427)	□18.66 (□474)	1247 (566)	52.60 (1336)	-	-	-	-	1344 (610)
CHHM25-6215DBY-EP		22.64 (575)	-		51.61 (1311)			1336 (606)	58.46 (1485)					1433 (650)
CHHM30-6215Y-EP	30 x 4 (22 x 4)	22.64 (575)	-	16.33 (415)	45.75 (1162)	16.81 (427)	□18.66 (□474)	1247 (566)	52.60 (1336)	15.91 (404)	□15.28 (□388)	12.13 (308)	-	1344 (610)
CHHM30-6215DBY-EP		22.64 (575)	-		51.61 (1311)			1336 (606)	58.46 (1485)					1433 (650)
CHHM40-6215Y-EP	40 x 4 (30 x 4)	22.64 (575)	-	16.33 (415)	50.63 (1286)	16.81 (427)	□18.66 (□474)	1360 (617)	57.48 (1460)	-	-	-	-	1457 (661)
CHHM50-6215Y-EP	50 x 4 (37 x 4)	22.64 (575)	-	16.33 (415)	52.09 (1323)	16.81 (427)	□18.66 (□474)	1428 (648)	-	-	-	-	-	-
CHHM60-6215Y-EP	60 x 4 (45 x 4)	22.64 (575)	-	16.33 (415)	52.09 (1323)	16.81 (427)	□18.66 (□474)	1556 (706)	-	-	-	-	-	-
CHHM75-6215Y-EP	75 x 4 (55 x 4)	22.64 (575)	-	16.33 (415)	52.09 (1323)	16.81 (427)	□18.66 (□474)	1636 (742)	-	-	-	-	-	-

Note: [1] MP Dimension Symbol ϕ = Round Fan Cover
MP Dimension Symbol \square = Square Fan Cover

Dimensions Integral Horizontal Foot Mount

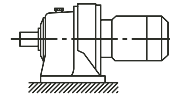

CHHM2-6225DAY-EP ▶ CHHM75-6225Y-EP

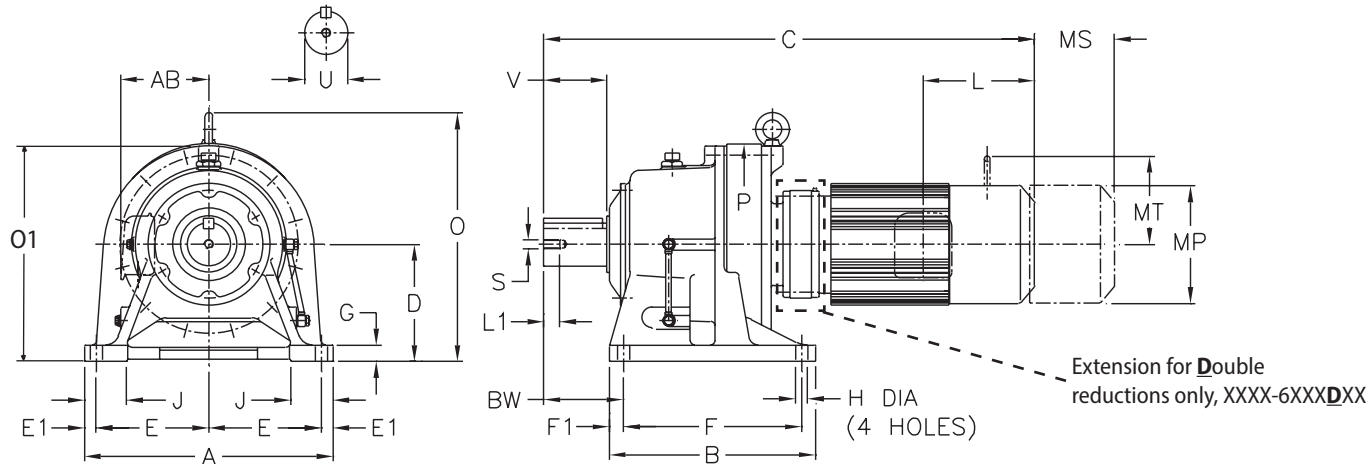

Table 1: Shaft Tolerances All dimensions are in inches (mm)

Low Speed Shaft Nominal Diameter	Tolerance Inches
0.500 through 0.625 (12.700 through 15.875)	+0.0000 / -0.0004 (+0.000 / -0.011)
0.750 through 1.125 (19.050 through 28.757)	+0.0000 / -0.0005 (+0.000 / -0.013)
1.250 through 1.875 (31.750 through 47.625)	+0.0000 / -0.0006 (+0.000 / -0.016)
2.000 through 3.125 (50.800 through 79.375)	+0.0000 / -0.0007 (+0.000 / -0.019)
3.250 through 4.625 (82.550 through 117.475)	+0.0000 / -0.0009 (+0.000 / -0.022)
4.750 through 7.000 (120.650 through 177.800)	+0.0000 / -0.0010 (+0.000 / -0.025)

Note: CHHM units are oil lubricated standard, must be installed as shown above.

Dimensions are in inches (mm)

Model	A	B	D	E	E1	F	F1	G	H	J	P	BW
6225Y	24.41 (620)	20.47 (520)	11.024 (280)	10.63 (270)	1.57 (40)	16.54 (420)	1.97 (50)	1.57 (40)	1.30 (33)	4.53 (115)	20.71 (526)	9.06 (230)

All dimensions are in inches (mm)

Model	Low Speed Shaft				Key
	U ^[A]	V	S	L1	
6225Y	4.63 (117.475)	6.50 (165)	3/4-10UNC	1.34 (34)	1-1/4 x 7/8 x 6.5 (31.75 x 22.225 x 165)

Note: [A] Toleranced dimension, please refer to Table 1 above.

Dimensions Integral Horizontal Foot Mount

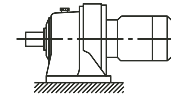

CHHM2-6225DAY-EP ▶ CHHM75-6225Y-EP

XXXX-6XX0/6XX5 Frame sizes have equal dimensions, different ratings.

All dimensions are in inches (mm), lbs (kg)

Model	HP x P (kW x P)	O	O1	AB	Without Brake				With Brake					
					C	ML	MP ^[1]	Weight lb (kg)	C	ML	MP ^[1]	MS	MT	Weight lb (kg)
CHHM2-6225DAY-EP	2 x 4 (1.5 x 4)	24.02 (610)	-	6.16 (156)	39.37 (1000)	3.82 (97)	□6.57 (□167)	988 (449)	42.11 (1070)	6.56 (167)	□6.57 (□167)	5.04 (128)	4.61 (117)	1000 (454)
CHHM3-6225DAY-EP	3 x 4 (2.2 x 4)	24.02 (610)	-	6.71 (170)	38.78 (985)	4.53 (115)	□7.24 (□184)	1000 (454)	41.85 (1063)	7.60 (193)	□7.24 (□184)	5.43 (138)	5.04 (128)	1016 (461)
CHHM5-6225DAY-EP	5 x 4 (3.7 x 4)	24.02 (610)	-	7.34 (186)	40.04 (1017)	4.65 (118)	□8.74 (□222)	1024 (465)	43.60 (1108)	8.21 (209)	□8.74 (□222)	6.02 (153)	6.30 (160)	1048 (476)
CHHM5-6225DBY-EP		24.02 (610)	45.69 (1161)		1124 (510)			48.78 (1151)	1148 (521)					
CHHM8-6225DAY-EP	7.5 x 4 (5.5 x 4)	24.02 (610)	-	9.04 (230)	41.73 (1060)	5.43 (138)	□10.24 (□260)	1058 (480)	45.30 (1151)	9.57 (243)	□10.24 (□260)	7.44 (189)	7.32 (186)	1082 (491)
CHHM8-6225DBY-EP		24.02 (610)	47.38 (1204)		1158 (526)			1182 (537)						
CHHM10-6225DAY-EP	10 x 4 (7.5 x 4)	24.02 (610)	-	10.26 (261)	43.23 (1098)	7.01 (178)	□12.49 (□317)	1085 (492)	47.36 (1203)	12.30 (313)	□12.61 (□320)	9.53 (242)	-	1129 (512)
CHHM10-6225DBY-EP		24.02 (610)	48.78 (1239)		1187 (539)			1232 (559)						
CHHM15-6225DAY-EP	15 x 4 (11 x 4)	24.02 (610)	-	13.39 (340)	45.67 (1160)	9.06 (230)	□15.12 (□384)	1097 (498)	49.80 (1265)	15.91 (404)	□15.28 (□388)	12.13 (308)	-	1142 (518)
CHHM15-6225DBY-EP		24.02 (610)	51.22 (1301)		1200 (545)			1244 (565)						
CHHM20-6225DAY-EP	20 x 4 (15 x 4)	24.02 (610)	-	16.33 (415)	48.11 (1222)	16.81 (427)	□18.66 (□474)	1178 (535)	53.41 (1357)	-	-	-	-	1264 (574)
CHHM20-6225DBY-EP		24.02 (610)	55.10 (1400)		1281 (581)			1367 (620)						
CHHM25-6225Y-EP	25 x 4 (18.5 x 4)	24.02 (610)	-	16.33 (415)	47.32 (1202)	16.81 (427)	□18.66 (□474)	1426 (647)	54.17 (1376)	-	-	-	-	1523 (691)
CHHM25-6225DBY-EP		24.02 (610)	60.83 (1545)		1560 (708)			1657 (752)						
CHHM30-6225Y-EP	30 x 4 (22 x 4)	24.02 (610)	-	16.33 (415)	47.32 (1202)	16.81 (427)	□18.66 (□474)	1426 (647)	54.17 (1376)	15.91 (404)	□15.28 (□388)	12.13 (308)	-	1523 (691)
CHHM30-6225DBY-EP		24.02 (610)	60.83 (1545)		1560 (708)			1657 (752)						
CHHM40-6225Y-EP	40 x 4 (30 x 4)	24.02 (610)	-	16.33 (415)	52.20 (1326)	16.81 (427)	□18.66 (□474)	1539 (698)	59.06 (1500)	-	-	-	-	1636 (742)
CHHM40-6225DBY-EP		24.02 (610)	65.71 (1669)		1673 (759)			1770 (803)						
CHHM50-6225Y-EP	50 x 4 (37 x 4)	24.02 (610)	-	16.33 (415)	52.20 (1326)	16.81 (427)	□18.66 (□474)	1607 (729)	-	-	-	-	-	-
CHHM60-6225Y-EP	60 x 4 (45 x 4)	24.02 (610)	-	16.33 (415)	53.66 (1363)	16.81 (427)	□18.66 (□474)	1732 (786)	-	-	-	-	-	-
CHHM75-6225Y-EP	75 x 4 (55 x 4)	24.02 (610)	-	16.33 (415)	53.66 (1363)	16.81 (427)	□18.66 (□474)	1812 (822)	-	-	-	-	-	-

Note: [1] MP Dimension Symbol ϕ = Round Fan Cover
MP Dimension Symbol \square = Square Fan Cover

Dimensions Integral Horizontal Foot Mount

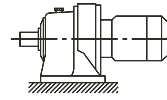

CHHM3-6235DAY-EP ▶ CHHM50-6245DBY-EP

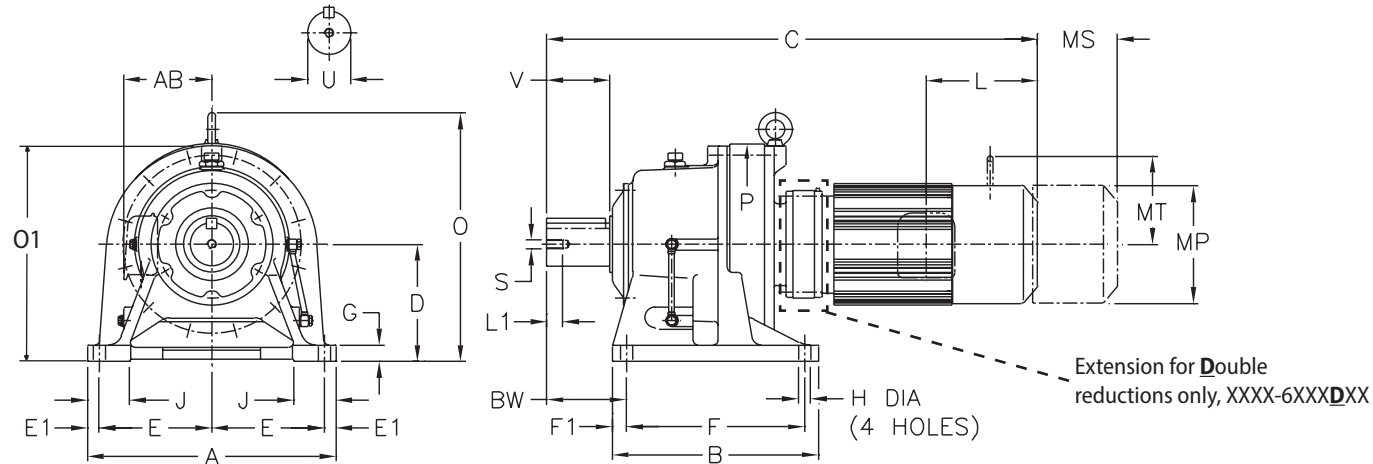

Table 1: Shaft Tolerances All dimensions are in inches (mm)

Low Speed Shaft Nominal Diameter	Tolerance Inches
0.500 through 0.625 (12.700 through 15.875)	+0.0000 / -0.0004 (+0.000 / -0.011)
0.750 through 1.125 (19.050 through 28.757)	+0.0000 / -0.0005 (+0.000 / -0.013)
1.250 through 1.875 (31.750 through 47.625)	+0.0000 / -0.0006 (+0.000 / -0.016)
2.000 through 3.125 (50.800 through 79.375)	+0.0000 / -0.0007 (+0.000 / -0.019)
3.250 through 4.625 (82.550 through 117.475)	+0.0000 / -0.0009 (+0.000 / -0.022)
4.750 through 7.000 (120.650 through 177.800)	+0.0000 / -0.0010 (+0.000 / -0.025)

Note: CHHM units are oil lubricated standard, must be installed as shown above.

Dimensions are in inches (mm)

Model	A	B	D	E	E1	F	F1	G	H	J	P	BW
6235DAY 6235DBY	26.38 (670)	22.05 (560)	11.811 (300)	11.42 (290)	1.77 (45)	18.11 (460)	1.97 (50)	1.77 (45)	1.30 (33)	4.72 (120)	22.13 (562)	10.24 (260)
6245DAY 6245DBY	28.35 (720)	22.83 (580)	13.189 (335)	12.40 (315)	1.77 (45)	18.90 (480)	1.97 (50)	1.77 (45)	1.54 (39)	5.04 (128)	24.17 (614)	10.35 (263)

All dimensions are in inches (mm)

Model	Low Speed Shaft				
	U ^[A]	V	S	L1	Key
6235DAY 6235DBY	5.00 (127)	7.87 (200)	1-8UNC	1.61 (41)	1-1/4 x 7/8 x 7.87 (31.75 x 22.225 x 200)
6245DAY 6245DBY	5.50 (139.7)	7.87 (200)	1-8UNC	1.61 (41)	1-1/4 x 7/8 x 7.87 (31.75 x 22.225 x 200)

Note: [A] Toleranced dimension, please refer to Table 1 above.

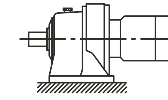

Dimensions Integral Horizontal Foot Mount

CHHM3-6235DAY-EP ▶ CHHM50-6245DBY-EP

XXXX-6XX0/6XX5 Frame sizes have equal dimensions, different ratings.

All dimensions are in inches (mm), lbs (kg)

Model	HP x P (kW x P)	O	O1	AB	Without Brake				With Brake					
					C	ML	MP ^[1]	Weight lb (kg)	C	ML	MP ^[1]	MS	MT	Weight lb (kg)
CHHM3-6235DAY-EP	3 x 4 (2.2 x 4)	26.26 (667)	-	6.71 (170)	42.17 (1071)	4.53 (115)	□7.24 (□184)	1255 (569)	45.24 (1149)	7.60 (193)	□7.24 (□184)	5.43 (138)	5.04 (128)	1271 (577)
CHHM5-6235DAY-EP	5 x 4 (3.7 x 4)	26.26 (667)	-	7.34 (186)	43.62 (1108)	4.65 (118)	□8.74 (□222)	1280 (581)	47.19 (1199)	8.21 (209)	□8.74 (□222)	6.02 (153)	6.30 (160)	1303 (591)
CHHM8-6235DAY-EP	7.5 x 4 (5.5 x 4)	26.26 (667)	-	9.04 (230)	45.31 (1151)	5.43 (138)	□10.24 (□260)	1313 (596)	48.88 (1242)	9.57 (243)	□10.24 (□260)	7.44 (189)	7.32 (186)	1337 (607)
CHHM10-6235DAY-EP	10 x 4 (7.5 x 4)	26.26 (667)	-	10.26 (261)	46.77 (1188)	7.01 (178)	□12.49 (□317)	1341 (609)	50.91 (1293)	12.30 (313)	□12.61 (□320)	9.53 (242)	-	1386 (629)
CHHM15-6235DAY-EP	15 x 4 (11 x 4)	26.26 (667)	-	13.39 (340)	49.21 (1250)	9.06 (230)	□15.12 (□384)	1354 (614)	53.35 (1355)	15.91 (404)	□15.28 (□388)	12.13 (308)	-	1398 (634)
CHHM15-6235DBY-EP	15 x 4 (11 x 4)	26.26 (667)	-	13.39 (340)	49.76 (1264)	9.06 (230)	□15.12 (□384)	1432 (650)	53.90 (1369)	15.91 (404)	□15.28 (□388)	12.13 (308)	-	1476 (670)
CHHM20-6235DAY-EP	20 x 4 (15 x 4)	26.26 (667)	-	13.39 (340)	51.50 (1308)	9.06 (230)	□15.12 (□384)	1437 (652)	56.79 (1443)	15.91 (404)	□15.28 (□388)	12.13 (308)	-	1523 (691)
CHHM20-6235DBY-EP	20 x 4 (15 x 4)	26.26 (667)	-	13.39 (340)	52.36 (1330)	9.06 (230)	□15.12 (□384)	1512 (686)	57.66 (1465)	15.91 (404)	□15.28 (□388)	12.13 (308)	-	1598 (725)
CHHM25-6235DAY-EP	25 x 4 (18.5 x 4)	26.26 (667)	-	13.39 (340)	55.67 (1414)	9.06 (230)	□15.12 (□384)	1715 (778)	62.52 (1588)	15.91 (404)	□15.28 (□388)	12.13 (308)	-	1812 (822)
CHHM25-6235DBY-EP	25 x 4 (18.5 x 4)	26.26 (667)	-	13.39 (340)	56.54 (1436)	9.06 (230)	□15.12 (□384)	1789 (812)	63.39 (1610)	15.91 (404)	□15.28 (□388)	12.13 (308)	-	1886 (856)
CHHM30-6235DAY-EP	30 x 4 (22 x 4)	26.26 (667)	-	13.39 (340)	55.67 (1414)	9.06 (230)	□15.12 (□384)	1715 (778)	62.52 (1588)	15.91 (404)	□15.28 (□388)	12.13 (308)	-	1812 (822)
CHHM30-6235DBY-EP	30 x 4 (22 x 4)	26.26 (667)	-	13.39 (340)	56.54 (1436)	9.06 (230)	□15.12 (□384)	1789 (812)	63.39 (1610)	15.91 (404)	□15.28 (□388)	12.13 (308)	-	1886 (856)
CHHM40-6235DBY-EP	40 x 4 (30 x 4)	26.26 (667)	-	13.39 (340)	61.42 (1560)	9.06 (230)	□15.12 (□384)	1902 (863)	68.27 (1734)	15.91 (404)	□15.28 (□388)	12.13 (308)	-	1999 (907)
CHHM50-6235DBY-EP	50 x 4 (37 x 4)	26.26 (667)	-	13.39 (340)	61.42 (1560)	9.06 (230)	□15.12 (□384)	1970 (894)	68.27 (1734)	15.91 (404)	□15.28 (□388)	12.13 (308)	-	2050 (930)

CHHM3-6245DAY-EP	3 x 4 (2.2 x 4)	28.70 (729)	-	6.71 (170)	43.66 (1109)	4.53 (115)	□7.24 (□184)	1493 (677)	46.73 (1187)	7.60 (193)	□7.24 (□184)	5.43 (138)	5.04 (128)	1510 (685)
CHHM5-6245DAY-EP	5 x 4 (3.7 x 4)	28.70 (729)	-	7.34 (186)	45.12 (1146)	4.65 (118)	□8.74 (□222)	1518 (689)	48.68 (1237)	8.21 (209)	□8.74 (□222)	6.02 (153)	6.30 (160)	1541 (699)
CHHM8-6245DAY-EP	7.5 x 4 (5.5 x 4)	28.70 (729)	-	9.04 (230)	46.81 (1189)	5.43 (138)	□10.24 (□260)	1552 (704)	50.37 (1280)	9.57 (243)	□10.24 (□260)	7.44 (189)	7.32 (186)	1575 (715)
CHHM10-6245DAY-EP	10 x 4 (7.5 x 4)	28.70 (729)	-	10.26 (261)	48.27 (1226)	7.01 (178)	□12.49 (□317)	1579 (717)	52.40 (1331)	12.30 (313)	□12.61 (□320)	9.53 (242)	-	1624 (737)
CHHM15-6245DAY-EP	15 x 4 (11 x 4)	28.70 (729)	-	13.39 (340)	50.71 (1288)	9.06 (230)	□15.12 (□384)	1592 (722)	54.84 (1393)	15.91 (404)	□15.28 (□388)	12.13 (308)	-	1636 (742)
CHHM15-6245DBY-EP	15 x 4 (11 x 4)	28.70 (729)	-	13.39 (340)	51.22 (1301)	9.06 (230)	□15.12 (□384)	1661 (754)	55.35 (1406)	15.91 (404)	□15.28 (□388)	12.13 (308)	-	1706 (774)
CHHM20-6245DAY-EP	20 x 4 (15 x 4)	28.70 (729)	-	13.39 (340)	52.99 (1346)	9.06 (230)	□15.12 (□384)	1675 (760)	58.29 (1481)	15.91 (404)	□15.28 (□388)	12.13 (308)	-	1761 (799)
CHHM20-6245DBY-EP	20 x 4 (15 x 4)	28.70 (729)	-	13.39 (340)	53.82 (1367)	9.06 (230)	□15.12 (□384)	1741 (790)	59.11 (1502)	15.91 (404)	□15.28 (□388)	12.13 (308)	-	1827 (829)
CHHM25-6245DAY-EP	25 x 4 (18.5 x 4)	28.70 (729)	-	13.39 (340)	57.17 (1452)	9.06 (230)	□15.12 (□384)	1953 (886)	64.02 (1626)	15.91 (404)	□15.28 (□388)	12.13 (308)	-	2050 (930)
CHHM25-6245DBY-EP	25 x 4 (18.5 x 4)	28.70 (729)	-	13.39 (340)	57.99 (1473)	9.06 (230)	□15.12 (□384)	2018 (916)	64.84 (1647)	15.91 (404)	□15.28 (□388)	12.13 (308)	-	2115 (960)
CHHM30-6245DAY-EP	30 x 4 (22 x 4)	28.70 (729)	-	13.39 (340)	57.17 (1452)	9.06 (230)	□15.12 (□384)	1953 (886)	64.02 (1626)	15.91 (404)	□15.28 (□388)	12.13 (308)	-	2050 (930)
CHHM30-6245DBY-EP	30 x 4 (22 x 4)	28.70 (729)	-	13.39 (340)	57.99 (1473)	9.06 (230)	□15.12 (□384)	2018 (916)	64.84 (1647)	15.91 (404)	□15.28 (□388)	12.13 (308)	-	2115 (960)
CHHM40-6245DBY-EP	40 x 4 (30 x 4)	28.70 (729)	-	13.39 (340)	62.87 (1597)	9.06 (230)	□15.12 (□384)	2131 (967)	69.72 (1771)	15.91 (404)	□15.28 (□388)	12.13 (308)	-	2228 (1011)
CHHM50-6245DBY-EP	50 x 4 (37 x 4)	28.70 (729)	-	13.39 (340)	62.87 (1597)	9.06 (230)	□15.12 (□384)	2200 (998)	69.72 (1771)	15.91 (404)	□15.28 (□388)	12.13 (308)	-	2228 (1011)

Note: [1] MP Dimension Symbol ϕ = Round Fan Cover
MP Dimension Symbol \square = Square Fan Cover

Dimensions Integral Horizontal Foot Mount

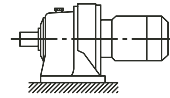

CHHM5-6255DAY-EP ▶ CHHM60-6275DAY-EP

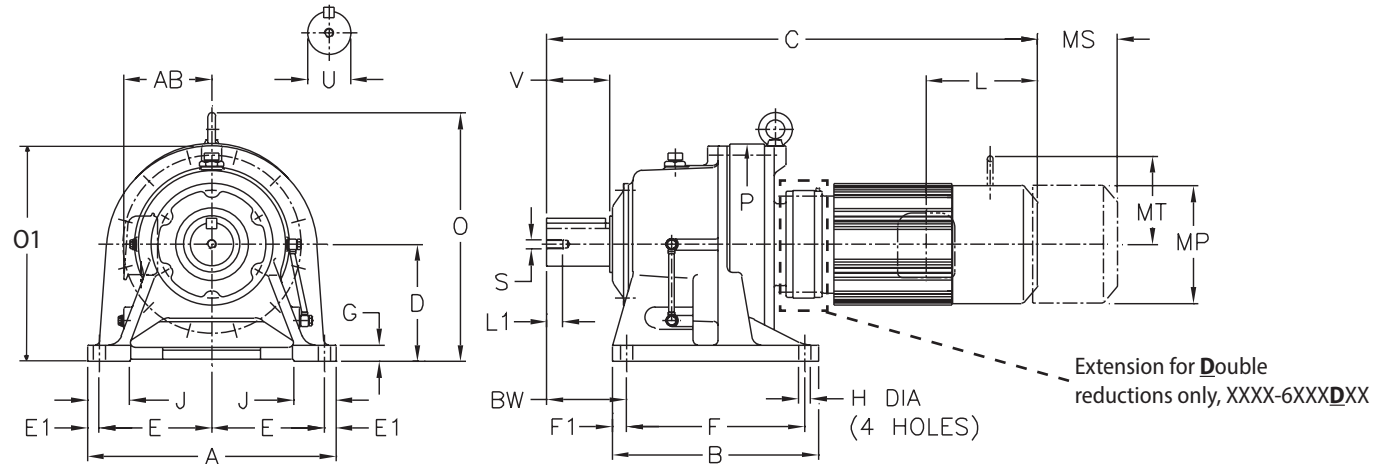

Table 1: Shaft Tolerances All dimensions are in inches (mm)

Low Speed Shaft Nominal Diameter	Tolerance Inches
0.500 through 0.625 (12.700 through 15.875)	+0.0000 / -0.0004 (+0.000 / -0.011)
0.750 through 1.125 (19.050 through 28.757)	+0.0000 / -0.0005 (+0.000 / -0.013)
1.250 through 1.875 (31.750 through 47.625)	+0.0000 / -0.0006 (+0.000 / -0.016)
2.000 through 3.125 (50.800 through 79.375)	+0.0000 / -0.0007 (+0.000 / -0.019)
3.250 through 4.625 (82.550 through 117.475)	+0.0000 / -0.0009 (+0.000 / -0.022)
4.750 through 7.000 (120.650 through 177.800)	+0.0000 / -0.0010 (+0.000 / -0.025)

Note: CHHM units are oil lubricated standard, must be installed as shown above.

Dimensions are in inches (mm)

Model	A	B	D	E	E1	F	F1	G	H	J	P	BW
6255DAY 6255DBY	30.71 (780)	24.80 (630)	14.764 (375)	13.19 (335)	2.17 (55)	20.47 (520)	2.17 (55)	1.97 (50)	1.54 (39)	5.51 (140)	26.38 (670)	12.60 (320)
6265DAY	34.65 (880)	27.56 (700)	15.748 (400)	15.16 (385)	2.17 (55)	23.23 (590)	2.17 (55)	2.17 (55)	1.77 (45)	6.30 (160)	28.98 (736)	15.35 (390)
6275DAY	45.67 (1160)	40.94 (1040)	21.260 (540)	20.67 (525)	2.17 (55)	16.54 (420)	3.94 (100)	2.36 (60)	1.77 (45)	7.87 (200)	37.40 (950)	19.09 (485)

All dimensions are in inches (mm)

Model	Low Speed Shaft				
	U ^[A]	V	S	L1	Key
6255DAY 6255DBY	6.25 (158.75)	9.45 (240)	1-1/4-7UNC	2.05 (52)	1-1/2 x 1 x 9.45 (38.1 x 25.4 x 240)
6265DAY	6.63 (168.275)	11.81 (300)	1-1/4-7UNC	2.05 (52)	1-3/4 x 1-1/4 x 11.81 (44.45 x 31.75 x 300)
6275DAY	7.00 (177.8)	12.99 (330)	1-1/4-7UNC	2.05 (52)	1-3/4 x 1-1/4 x 12.6 (44.45 x 31.75 x 330)

Note: [A] Toleranced dimension, please refer to Table 1 above.

Dimensions Integral Horizontal Foot Mount

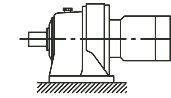

CHHM5-6255DAY-EP ▶ CHHM60-6275DAY-EP

XXXX-6XX0/6XX5 Frame sizes have equal dimensions, different ratings.

All dimensions are in inches (mm), lbs (kg)

Model	HP x P (kW x P)	O	O1	AB	Without Brake				With Brake					
					C	ML	MP ^[1]	Weight lb (kg)	C	ML	MP ^[1]	MS	MT	Weight lb (kg)
CHHM5-6255DAY-EP	5 x 4 (3.7 x 4)	32.09 (815)	-	7.34 (186)	50.83 (1291)	4.65 (118)	□8.74 (□222)	2302 (1044)	54.39 (1382)	8.21 (209)	□8.74 (□222)	6.02 (153)	6.30 (160)	2326 (1055)
CHHM8-6255DAY-EP	7.5 x 4 (5.5 x 4)	32.09 (815)	-	9.04 (230)	52.52 (1334)	5.43 (138)	□10.24 (□260)	2336 (1060)	56.08 (1425)	9.57 (243)	□10.24 (□260)	7.44 (189)	7.32 (186)	2360 (1071)
CHHM10-6255DAY-EP	10 x 4 (7.5 x 4)	32.09 (815)	-	10.26 (261)	53.35 (1355)	7.01 (178)	□12.49 (□317)	2365 (1073)	57.48 (1460)	12.30 (313)	□12.61 (□320)	9.53 (242)	-	2409 (1093)
CHHM15-6255DAY-EP	15 x 4 (11 x 4)	32.09 (815)	-	13.39 (340)	55.79 (1417)	9.06 (230)	□15.12 (□384)	2377 (1079)	59.92 (1522)	15.91 (404)	□15.28 (□388)	12.13 (308)	-	2421 (1099)
CHHM15-6255DBY-EP	15 x 4 (11 x 4)	32.09 (815)	-	13.39 (340)	56.65 (1439)	9.06 (230)	□15.12 (□384)	2539 (1152)	60.79 (1544)	15.91 (404)	□15.28 (□388)	12.13 (308)	-	2583 (1172)
CHHM20-6255DAY-EP	20 x 4 (15 x 4)	32.09 (815)	-	16.33 (415)	58.50 (1486)	9.06 (230)	□15.12 (□384)	2458 (1115)	63.80 (1621)	15.91 (404)	□15.28 (□388)	12.13 (308)	-	2544 (1154)
CHHM20-6255DBY-EP	20 x 4 (15 x 4)	32.09 (815)	-	16.33 (415)	59.37 (1508)	9.06 (230)	□15.12 (□384)	2617 (1187)	64.67 (1643)	15.91 (404)	□15.28 (□388)	12.13 (308)	-	2703 (1226)
CHHM25-6255DAY-EP	25 x 4 (18.5 x 4)	32.09 (815)	-	16.33 (415)	62.68 (1592)	9.06 (230)	□15.12 (□384)	2737 (1242)	69.53 (1766)	15.91 (404)	□15.28 (□388)	12.13 (308)	-	2834 (1286)
CHHM25-6255DBY-EP	25 x 4 (18.5 x 4)	32.09 (815)	-	16.33 (415)	63.54 (1614)	9.06 (230)	□15.12 (□384)	2895 (1314)	70.39 (1788)	15.91 (404)	□15.28 (□388)	12.13 (308)	-	2992 (1358)
CHHM30-6255DAY-EP	30 x 4 (22 x 4)	32.09 (815)	-	16.33 (415)	62.68 (1592)	9.06 (230)	□15.12 (□384)	2737 (1242)	69.53 (1766)	15.91 (404)	□15.28 (□388)	12.13 (308)	-	2834 (1286)
CHHM30-6255DBY-EP	30 x 4 (22 x 4)	32.09 (815)	-	16.33 (415)	63.54 (1614)	9.06 (230)	□15.12 (□384)	2895 (1314)	70.39 (1788)	15.91 (404)	□15.28 (□388)	12.13 (308)	-	2992 (1358)
CHHM40-6255DAY-EP	40 x 4 (30 x 4)	32.09 (815)	-	16.33 (415)	67.56 (1716)	9.06 (230)	□15.12 (□384)	2850 (1293)	74.41 (1890)	15.91 (404)	□15.28 (□388)	12.13 (308)	-	2947 (1337)
CHHM40-6255DBY-EP	40 x 4 (30 x 4)	32.09 (815)	-	16.33 (415)	68.43 (1738)	9.06 (230)	□15.12 (□384)	3008 (1365)	75.28 (1912)	15.91 (404)	□15.28 (□388)	12.13 (308)	-	3105 (1409)
CHHM50-6255DBY-EP	50 x 4 (37 x 4)	32.09 (815)	-	16.33 (415)	3077 (1396)	-	-	-	-	-	-	-	-	-
CHHM60-6255DBY-EP	60 x 4 (45 x 4)	32.09 (815)	-	16.33 (415)	3205 (1454)	-	-	-	-	-	-	-	-	-
CHHM8-6265DAY-EP	7.5 x 4 (5.5 x 4)	34.41 (874)	-	9.04 (230)	58.31 (1481)	5.43 (138)	□10.24 (□260)	3058 (1387)	61.87 (1572)	8.21 (209)	□8.74 (□222)	6.02 (153)	6.30 (160)	3081 (1398)
CHHM10-6265DAY-EP	10 x 4 (7.5 x 4)	34.41 (874)	-	10.26 (261)	58.54 (1487)	7.01 (178)	□12.49 (□317)	3088 (1401)	62.68 (1592)	9.57 (243)	□10.24 (□260)	7.44 (189)	7.32 (186)	3132 (1421)
CHHM15-6265DAY-EP	15 x 4 (11 x 4)	34.41 (874)	-	13.39 (340)	60.98 (1549)	9.06 (230)	□15.12 (□384)	3101 (1407)	65.12 (1654)	12.30 (313)	□12.61 (□320)	9.53 (242)	-	3145 (1427)
CHHM20-6265DAY-EP	20 x 4 (15 x 4)	34.41 (874)	-	16.33 (415)	34.41 (874)	9.06 (230)	□15.12 (□384)	3179 (1442)	69.00 (1753)	15.91 (404)	□15.28 (□388)	12.13 (308)	-	3265 (1481)
CHHM25-6265DAY-EP	25 x 4 (18.5 x 4)	34.41 (874)	-	16.33 (415)	34.41 (874)	9.06 (230)	□15.12 (□384)	3457 (1569)	74.72 (1898)	15.91 (404)	□15.28 (□388)	12.13 (308)	-	3554 (1613)
CHHM30-6265DAY-EP	30 x 4 (22 x 4)	34.41 (874)	-	16.33 (415)	34.41 (874)	9.06 (230)	□15.12 (□384)	3457 (1569)	74.72 (1898)	15.91 (404)	□15.28 (□388)	12.13 (308)	-	3554 (1613)
CHHM40-6265DAY-EP	40 x 4 (30 x 4)	34.41 (874)	-	16.33 (415)	34.41 (874)	9.06 (230)	□15.12 (□384)	3570 (1620)	79.61 (2022)	15.91 (404)	□15.28 (□388)	12.13 (308)	-	3667 (1664)
CHHM50-6265DAY-EP	50 x 4 (37 x 4)	34.41 (874)	-	16.33 (415)	3639 (1651)	-	-	-	-	-	-	-	-	-
CHHM60-6265DAY-EP	60 x 4 (45 x 4)	34.41 (874)	-	16.33 (415)	3767 (1709)	-	-	-	-	-	-	-	-	-
CHHM10-6275DAY-EP	10 x 4 (7.5 x 4)	45.71 (1161)	-	9.04 (230)	68.82 (1748)	5.43 (138)	□10.24 (□260)	5601 (2541)	72.95 (1853)	9.57 (243)	□10.24 (□260)	7.44 (189)	7.32 (186)	5646 (2561)
CHHM15-6275DAY-EP	15 x 4 (11 x 4)	45.71 (1161)	-	10.26 (261)	71.26 (1810)	7.01 (178)	□12.49 (□317)	5614 (2547)	75.39 (1915)	12.30 (313)	□12.61 (□320)	9.53 (242)	-	5658 (2567)
CHHM20-6275DAY-EP	20 x 4 (15 x 4)	45.71 (1161)	-	13.39 (340)	73.98 (1879)	9.06 (230)	□15.12 (□384)	5692 (2582)	79.27 (2014)	15.91 (404)	□15.28 (□388)	12.13 (308)	-	5778 (2621)
CHHM25-6275DAY-EP	25 x 4 (18.5 x 4)	45.71 (1161)	-	16.33 (415)	45.71 (1161)	9.06 (230)	□15.12 (□384)	5971 (2709)	85.00 (2159)	15.91 (404)	□15.28 (□388)	12.13 (308)	-	6068 (2753)
CHHM30-6275DAY-EP	30 x 4 (22 x 4)	45.71 (1161)	-	16.33 (415)	45.71 (1161)	9.06 (230)	□15.12 (□384)	5971 (2709)	85.00 (2159)	15.91 (404)	□15.28 (□388)	12.13 (308)	-	6068 (2753)
CHHM40-6275DAY-EP	40 x 4 (30 x 4)	45.71 (1161)	-	16.33 (415)	83.03 (2109)	9.06 (230)	□15.12 (□384)	6084 (2760)	89.88 (2283)	15.91 (404)	□15.28 (□388)	12.13 (308)	-	6181 (2804)
CHHM50-6275DAY-EP	50 x 4 (37 x 4)	45.71 (1161)	-	16.33 (415)	6152 (2791)	-	-	-	-	-	-	-	-	-
CHHM60-6275DAY-EP	60 x 4 (45 x 4)	45.71 (1161)	-	16.33 (415)	6280 (2849)	-	-	-	-	-	-	-	-	-

Note: [1] MP Dimension Symbol ϕ = Round Fan Cover
MP Dimension Symbol \square = Square Fan Cover

Dimensions Integral Universal V-Flange Mount

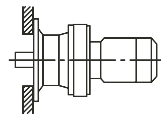

CNVM01-6065DAY ▶ CNVM1-6085Y-EP

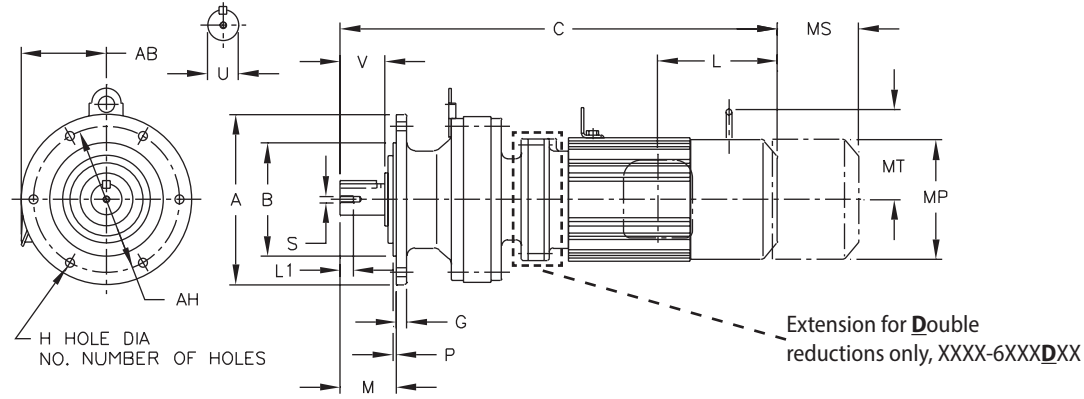

Table 1: Shaft Tolerances All dimensions are in inches (mm)

Low Speed Shaft Nominal Diameter	Tolerance Inches
0.500 through 0.625 (12.700 through 15.875)	+0.0000 / -0.0004 (+0.000 / -0.011)
0.750 through 1.125 (19.050 through 28.757)	+0.0000 / -0.0005 (+0.000 / -0.013)
1.250 through 1.875 (31.750 through 47.625)	+0.0000 / -0.0006 (+0.000 / -0.016)
2.000 through 3.125 (50.800 through 79.375)	+0.0000 / -0.0007 (+0.000 / -0.019)
3.250 through 4.625 (82.550 through 117.475)	+0.0000 / -0.0009 (+0.000 / -0.022)
4.750 through 7.000 (120.650 through 177.800)	+0.0000 / -0.0010 (+0.000 / -0.025)

Note: CNVM units are greased for life, and can be mounted in any position.

Dimensions are in inches (mm)

Model CNVM	A	B	G	H	NO.	M	O	P	AH
6060Y 6065Y	4.72 (120)	3.15 (80)	0.31 (8)	0.35 (9)	6	1.34 (34)	-	0.12 (3)	4.02 (102)
6070Y 6075Y	6.30 (160)	4.33 (110)	0.35 (9)	0.43 (11)	4	1.89 (42)	-	0.12 (3)	5.28 (134)
6080Y 6085Y	6.30 (160)	4.33 (110)	0.35 (9)	0.43 (11)	4	1.89 (48)	-	0.12 (3)	5.28 (134)

All dimensions are in inches (mm)

Model CNVM	Low Speed Shaft				
	U ^[A]	V	S	L1	Key
6060Y 6065Y	0.50 (12.7)	0.98 (25)	10-32UNF	0.63 (16)	1/8 X 1/8 X 0.79 (3.175 x 3.175 x 20.07)
6070Y 6075Y	0.75 (19.05)	1.18 (30)	12-28UNF	0.63 (16)	3/16 X 3/16 X 1.18 (4.762 x 4.762 x 30)
6080Y 6085Y	0.875 (22.23)	1.38 (35)	12-28UNF	0.63 (16)	3/16 X 3/16 X 1.18 (4.762 x 4.762 x 30)

Note: [A] Toleranced dimension, please refer to Table 1 above.

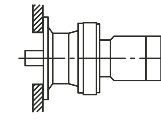

Dimensions Integral Universal V-Flange Mount

CNVM01-6065DAY ▶ CNVM1-6085Y-EP

XXXX-6XX0/6XX5 Frame sizes have equal dimensions, different ratings.

All dimensions are in inches (mm), lbs (kg)

Model	HP x P (kW x P)	AB	Without Brake				With Brake					
			C	ML	MP ^[1]	Weight lb (kg)	C	ML	MP ^[1]	MS	MT	Weight lb (kg)
CNVM01-6065DAY	1/8 x 4 (0.1 x 4)	4.63 (118)	10.20 (259)	1.38 (35)	ø4.69 (ø119)	19 (9)	11.57 (294)	2.76 (70)	ø4.88 (ø124)	1.93 (49)	-	22 (10)
CNVM01-6065Y-AV			10.55 (268)	2.32 (59)	ø4.88 (ø124)	18 (8)	11.81 (300)	3.58 (91)				21 (10)
CNVM01-6065DAY-AV			11.85 (301)	2.32 (59)	ø4.88 (ø124)	21 (10)	13.11 (333)	3.58 (91)				24 (11)
CNVM01-6065Y	1/4 x 4 (0.2 x 4)	4.63 (118)	8.90 (226)	1.38 (35)	ø4.69 (ø119)	16 (7)	10.28 (261)	2.76 (70)	ø4.88 (ø124)	1.93 (49)	-	19 (9)
CNVM02-6065Y			10.55 (268)	2.32 (59)	ø4.88 (ø124)	18 (8)	11.81 (300)	3.58 (91)				21 (10)
CNVM02-6065Y-AV			11.34 (288)	2.32 (59)	ø4.88 (ø124)	21 (10)	12.60 (320)	3.58 (91)				24 (11)
CNVM03-6065Y	1/3 x 4 (0.25 x 4)	4.63 (118)	10.55 (268)	2.32 (59)	ø4.88 (ø124)	18 (8)	11.81 (300)	3.58 (91)	ø4.88 (ø124)	2.40 (61)	-	21 (10)
CNVM03-6065Y-AV			11.34 (288)	2.32 (59)	ø4.88 (ø124)	21 (10)	12.60 (320)					24 (11)
CNVM01-6075DAY	1/8 x 4 (0.1 x 4)	4.63 (118)	10.43 (265)	1.38 (35)	ø4.69 (ø119)	23 (11)	11.81 (300)	2.76 (70)	ø4.88 (ø124)	1.93 (49)	-	26 (12)
CNVM01-6075Y-AV			10.79 (274)	2.32 (59)	ø4.88 (ø124)	20 (9)	12.05 (306)	3.58 (91)				23 (11)
CNVM01-6075DAY-AV			12.09 (307)	2.32 (59)	ø4.88 (ø124)	25 (12)	13.35 (339)	3.58 (91)				28 (13)
CNVM01-6075Y	1/4 x 4 (0.2 x 4)	4.63 (118)	9.13 (232)	1.38 (35)	ø4.69 (ø119)	18 (8)	10.51 (267)	2.76 (70)	ø4.88 (ø124)	1.93 (49)	-	21 (10)
CNVM02-6075Y			10.79 (274)	2.32 (59)	ø4.88 (ø124)	20 (9)	12.05 (306)	3.58 (91)				23 (11)
CNVM02-6075Y-AV			11.57 (294)	2.32 (59)	ø4.88 (ø124)	23 (11)	12.83 (326)	3.58 (91)				26 (12)
CNVM02-6075DAY	1/3 x 4 (0.25 x 4)	4.63 (118)	12.09 (307)	2.32 (59)	ø4.88 (ø124)	25 (12)	13.35 (339)	3.58 (91)	ø4.88 (ø124)	2.40 (61)	-	28 (13)
CNVM02-6075DAY-AV			12.87 (327)	2.32 (59)	ø4.88 (ø124)	28 (13)	14.13 (359)					31 (14)
CNVM03-6075Y			10.79 (274)	2.32 (59)	ø4.88 (ø124)	20 (9)	12.05 (306)					3.58 (91)
CNVM03-6075Y-AV	1/2 x 4 (0.4 x 4)	4.63 (118)	11.57 (294)	2.32 (59)	ø4.88 (ø124)	23 (11)	12.83 (326)	3.58 (91)	ø4.88 (ø124)	2.40 (61)	-	26 (12)
CNVM05-6075Y			11.57 (294)	2.32 (59)	ø4.88 (ø124)	23 (11)	12.83 (326)					26 (12)
CNVM01-6085Y	1/8 x 4 (0.1 x 4)	4.63 (118)	10.16 (258)	1.38 (35)	ø4.69 (ø119)	23 (11)	11.54 (293)	2.76 (70)	ø4.88 (ø124)	1.93 (49)	-	26 (12)
CNVM01-6085Y-AV			11.81 (300)	2.32 (59)	ø4.88 (ø124)	25 (12)	13.07 (332)	3.58 (91)				28 (13)
CNVM02-6085Y			12.60 (320)	2.32 (59)	ø4.88 (ø124)	28 (13)	13.86 (352)	3.58 (91)				31 (14)
CNVM02-6085Y-AV	1/4 x 4 (0.2 x 4)	4.63 (118)	12.60 (320)	2.32 (59)	ø4.88 (ø124)	28 (13)	13.86 (352)	3.58 (91)	ø4.88 (ø124)	2.40 (61)	-	31 (14)
CNVM03-6085Y			11.81 (300)	2.32 (59)	ø4.88 (ø124)	25 (12)	13.07 (332)					28 (13)
CNVM03-6085Y-AV			12.60 (320)	2.32 (59)	ø4.88 (ø124)	28 (13)	13.86 (352)					31 (14)
CNVM05-6085Y	1/2 x 4 (0.4 x 4)	4.63 (118)	12.60 (320)	2.32 (59)	ø4.88 (ø124)	28 (13)	13.86 (352)	3.58 (91)	ø4.88 (ø124)	2.40 (61)	-	31 (14)
CNVM05-6085Y-AV			12.60 (320)	2.32 (59)	ø4.88 (ø124)	28 (13)	13.86 (352)					31 (14)
CNVM08-6085Y	3/4 x 4 (0.55 x 4)	5.67 (144)	14.21 (361)	3.82 (97)	ø5.94 (ø151)	35 (16)	15.91 (404)	5.51 (140)	ø5.94 (ø151)	3.66 (93)	3.94 (100)	41 (19)
CNVM1-6085Y-EP	1 x 4 (0.75 x 4)	5.98 (152)	15.85 (403)	3.82 (97)	ø6.22 (ø158)	33 (15)	15.91 (404)	5.51 (140)	ø6.22 (ø158)	4.80 (122)	4.25 (108)	38 (18)
CNVM1-6085Y-EP	1 x 4 (0.75 x 4)	5.98 (152)	15.85 (403)	3.82 (97)	ø6.22 (ø158)	46 (21)	18.35 (466)	6.32 (161)	ø6.22 (ø158)	4.80 (122)	4.25 (108)	55 (25)

Note: [1] MP Dimension Symbol ø = Round Fan Cover
MP Dimension Symbol □ = Square Fan Cover

Dimensions Integral Universal V-Flange Mount

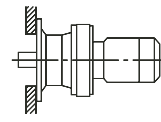

CNVM01-6095Y ▶ CNVM2-6095Y-EP

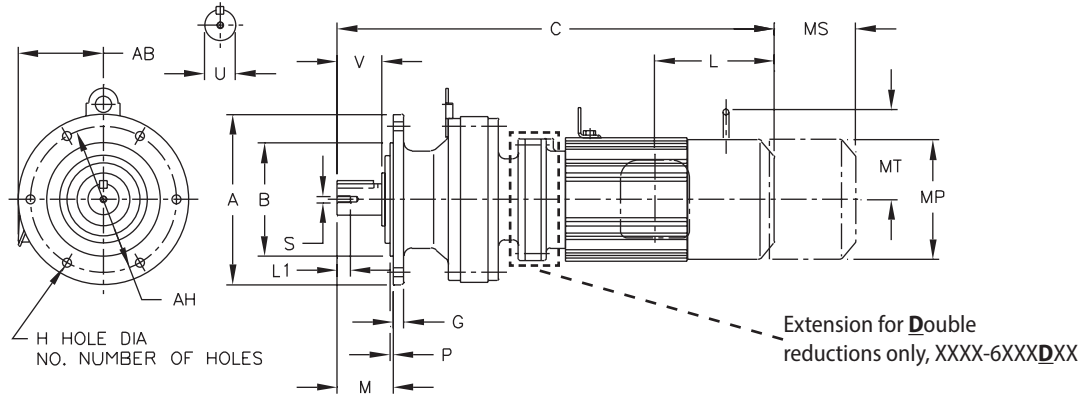

Table 1: Shaft Tolerances All dimensions are in inches (mm)

Low Speed Shaft Nominal Diameter	Tolerance Inches
0.500 through 0.625 (12.700 through 15.875)	+0.0000 / -0.0004 (+0.000 / -0.011)
0.750 through 1.125 (19.050 through 28.757)	+0.0000 / -0.0005 (+0.000 / -0.013)
1.250 through 1.875 (31.750 through 47.625)	+0.0000 / -0.0006 (+0.000 / -0.016)
2.000 through 3.125 (50.800 through 79.375)	+0.0000 / -0.0007 (+0.000 / -0.019)
3.250 through 4.625 (82.550 through 117.475)	+0.0000 / -0.0009 (+0.000 / -0.022)
4.750 through 7.000 (120.650 through 177.800)	+0.0000 / -0.0010 (+0.000 / -0.025)

Note: CNVM units are greased for life, and can be mounted in any position.

Dimensions are in inches (mm)

Model CNVM	A	B	G	H	NO.	M	O	P	AH
6090Y 6095Y	6.30 (160)	4.33 (110)	0.35 (9)	0.43 (11)	4	1.89 (48)	4.21 (107)	0.12 (3)	5.28 (134)

All dimensions are in inches (mm)

Model CNVM	Low Speed Shaft				
	U ^[A]	V	S	L1	Key
6090Y 6095Y	1.125 (28.58)	1.38 (35)	5/16-18UNC	0.79 (20)	1/4 X 1/4 X 1.18 (6.35 x 6.35 x 30)

Note: [A] Toleranced dimension, please refer to Table 1 above.

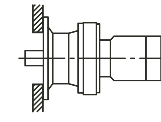

Dimensions Integral Universal V-Flange Mount

CNVM01-6095Y ▶ CNVM2-6095Y-EP

XXXX-6XX0/6XX5 Frame sizes have equal dimensions, different ratings.

All dimensions are in inches (mm), lbs (kg)

Model	HP x P (kW x P)	AB	Without Brake				With Brake								
			C	ML	MP ^[1]	Weight lb (kg)	C	ML	MP ^[1]	MS	MT	Weight lb (kg)			
CNVM01-6095Y	1/8 x 4 (0.1 x 4)	4.63 (118)	10.87 (276)	1.38 (35)	ø4.69 (ø119)	26 (12)	12.24 (311)	2.76 (70)	ø4.88 (ø124)	2.40 (61)	-	1.93 (49)	31 (14)		
CNVM01-6095Y-AV			12.52 (318)	2.32 (59)	ø4.88 (ø124)	28 (13)	13.78 (350)	3.58 (91)				2.40 (61)			
CNVM01-6095DAY			12.76 (324)	1.38 (35)	ø4.69 (ø119)	32 (15)	14.13 (359)	2.76 (70)				1.93 (49)			
CNVM01-6095DAY-AV			14.41 (366)	2.32 (59)	ø4.88 (ø124)	34 (16)	15.67 (398)	3.58 (91)				2.40 (61)		-	37 (17)
CNVM02-6095Y			12.52 (318)			28 (13)	13.78 (350)								
CNVM02-6095Y-AV			13.31 (338)			31 (14)	14.57 (370)								
CNVM02-6095DAY			14.41 (366)			34 (16)	15.67 (398)								
CNVM02-6095DAY-AV			15.20 (386)			37 (17)	16.46 (418)								
CNVM03-6095Y			12.52 (318)			28 (13)	13.78 (350)								
CNVM03-6095Y-AV			13.31 (338)			31 (14)	14.57 (370)								
CNVM03-6095DAY	14.41 (366)	34 (16)	15.67 (398)												
CNVM03-6095DAY-AV	15.20 (386)	37 (17)	16.46 (418)												
CNVM05-6095Y	13.31 (338)	31 (14)	14.57 (370)												
CNVM05-6095Y-AV	1/2 x 4 (0.4 x 4)	5.67 (144)	14.92 (379)	3.82 (97)	ø5.94 (ø151)	38 (18)	16.61 (422)	5.51 (140)	ø5.94 (ø151)	3.66 (93)	3.94 (100)	44 (20)			
CNVM05-6095DAY	4.63 (118)	15.20 (386)	2.32 (59)	ø4.88 (ø124)	37 (17)	16.46 (418)	3.58 (91)	ø4.88 (ø124)	2.40 (61)	-	40 (19)				
CNVM08-6095Y	3/4 x 4 (0.55 x 4)	5.67 (144)	14.92 (379)	3.82 (97)	ø5.94 (ø151)	36 (17)	16.61 (422)	5.51 (140)	ø5.94 (ø151)	3.66 (93)	3.94 (100)	42 (19)			
CNVM08-6095Y-AV	5.86 (149)	16.22 (412)	3.94 (100)	ø6.30 (ø160)	47 (21)	18.66 (474)	6.38 (162)	ø6.30 (ø160)	4.53 (115)	4.29 (109)	58 (26)				
CNVM1-6095Y-EP	1 x 4 (0.75 x 4)	5.98 (152)	16.65 (423)	3.82 (97)	□6.22 (□158)	52 (24)	19.15 (487)	6.32 (161)	□6.22 (□158)	4.80 (122)	4.25 (108)	61 (28)			
CNVM1H-6095Y-EP	1.5 x 4 (1.1 x 4)	6.16 (156)	17.72 (450)		□6.57 (□167)	59 (27)	20.45 (520)	6.56 (167)	□6.57 (□167)	5.04 (128)	4.61 (117)	71 (32)			
CNVM2-6095Y-EP	2 x 4 (1.5 x 4)				62 (28)	74 (34)									

Note: [1] MP Dimension Symbol ø = Round Fan Cover
MP Dimension Symbol □ = Square Fan Cover

Dimensions

Dimensions

Dimensions Integral Universal V-Flange Mount

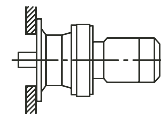

CNVM01-6105DAY ▶ CNVM5-6115Y-EP

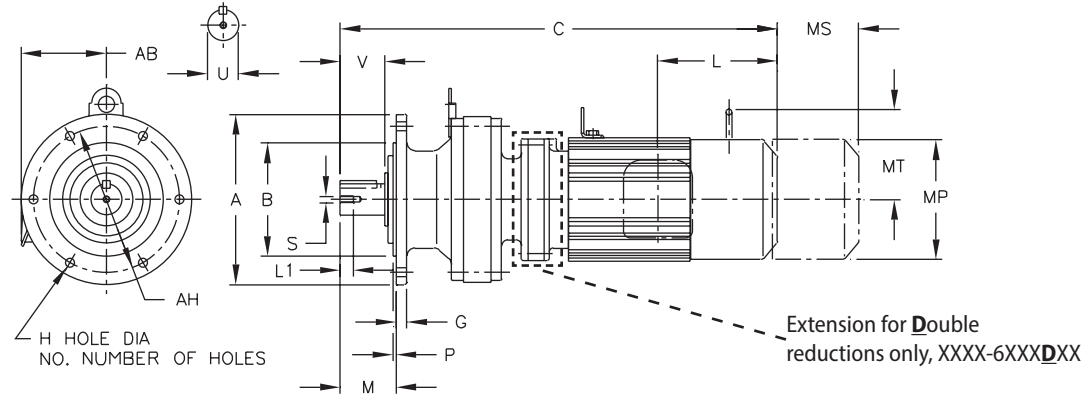

Table 1: Shaft Tolerances All dimensions are in inches (mm)

Low Speed Shaft Nominal Diameter	Tolerance Inches
0.500 through 0.625 (12.700 through 15.875)	+0.0000 / -0.0004 (+0.000 / -0.011)
0.750 through 1.125 (19.050 through 28.757)	+0.0000 / -0.0005 (+0.000 / -0.013)
1.250 through 1.875 (31.750 through 47.625)	+0.0000 / -0.0006 (+0.000 / -0.016)
2.000 through 3.125 (50.800 through 79.375)	+0.0000 / -0.0007 (+0.000 / -0.019)
3.250 through 4.625 (82.550 through 117.475)	+0.0000 / -0.0009 (+0.000 / -0.022)
4.750 through 7.000 (120.650 through 177.800)	+0.0000 / -0.0010 (+0.000 / -0.025)

Note: CNVM units are greased for life, and can be mounted in any position.

Dimensions are in inches (mm)

Model CNVM	A	B	G	H	NO.	M	O	P	AH
6100Y 6105Y	6.30 (160)	4.33 (110)	0.35 (9)	0.43 (11)	4	1.89 (48)	4.21 (107)	0.12 (3)	5.28 (134)
6110Y 6115Y	8.27 (210)	5.51 (140)	0.43 (11)	0.43 (11)	6	2.28 (58)	4.53 (115)	0.16 (4)	7.09 (180)

All dimensions are in inches (mm)

Model CNVM	Low Speed Shaft				Key
	U ^[A]	V	S	L1	
6100Y 6105Y	1.125 (28.58)	1.38 (35)	5/16-18UNC	0.79 (20)	1/4 X 1/4 X 1.18 (6.35 x 6.35 x 30)
6110Y 6115Y	1.25 (31.75)	1.77 (45)	5/16-18UNC	0.79 (20)	1/4 x 1/4 x 1.46 (6.35 x 6.35 x 37)

Note: [A] Toleranced dimension, please refer to Table 1 above.

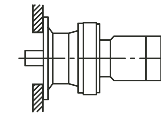

Dimensions Integral Universal V-Flange Mount

CNVM01-6105DAY ▶ CNVM5-6115Y-EP

XXXX-6XX0/6XX5 Frame sizes have equal dimensions, different ratings.

All dimensions are in inches (mm), lbs (kg)

Model	HP x P (kW x P)	AB	Without Brake				With Brake					
			C	ML	MP ^[1]	Weight lb (kg)	C	ML	MP ^[1]	MS	MT	Weight lb (kg)
CNVM01-6105DAY	1/8 x 4 (0.1 x 4)	4.63 (118)	13.31 (338)	1.38 (35)	ø4.69 (ø119)	37 (17)	14.69 (373)	2.76 (70)	ø4.88 (ø124)	2.40 (61)	-	40 (18)
CNVM01-6105DAY-AV			14.96 (380)			39 (18)	16.22 (412)					42 (19)
CNVM02-6105Y			13.07 (332)			33 (15)	14.33 (364)					36 (17)
CNVM02-6105Y-AV			13.86 (352)			36 (17)	15.12 (384)					39 (18)
CNVM02-6105DAY			14.96 (380)			39 (18)	16.22 (412)					42 (19)
CNVM02-6105DAY-AV			15.75 (400)			42 (19)	17.01 (432)					45 (21)
CNVM03-6105Y			13.07 (332)			33 (15)	14.33 (364)					36 (17)
CNVM03-6105Y-AV			13.86 (352)			36 (17)	15.12 (384)					39 (18)
CNVM03-6105DAY			14.96 (380)			39 (18)	16.22 (412)					42 (19)
CNVM03-6105DAY-AV			15.75 (400)			42 (19)	17.01 (432)					45 (21)
CNVM05-6105Y		13.86 (352)			36 (17)	15.12 (384)		39 (18)				
CNVM05-6105Y-AV	1/2 x 4 (0.4 x 4)	5.67 (144)	15.47 (393)	3.82 (97)	ø5.94 (ø151)	43 (20)	17.17 (436)	5.51 (140)	ø5.94 (ø151)	3.66 (93)	3.94 (100)	49 (23)
CNVM05-6105DAY		4.63 (118)	15.75 (400)	2.32 (59)	ø4.88 (ø124)	42 (19)	17.01 (432)	3.58 (91)	ø4.88 (ø124)	2.40 (61)	-	45 (21)
CNVM08-6105Y		5.67 (144)	15.47 (393)	3.82 (97)	ø5.94 (ø151)	41 (19)	17.17 (436)	5.51 (140)	ø5.94 (ø151)	3.66 (93)	3.94 (100)	46 (21)
CNVM08-6105Y-AV		5.86 (149)	16.77 (426)	3.94 (100)	ø6.30 (ø160)	51 (24)	19.21 (488)	6.38 (162)	ø6.30 (ø160)	4.53 (115)	4.29 (109)	62 (28)
CNVM1-6105Y-EP	1 x 4 (0.75 x 4)	5.98 (152)	17.20 (437)	3.82 (97)	□6.22 (□158)	56 (26)	19.70 (501)	6.32 (161)	□6.22 (□158)	4.80 (122)	4.25 (108)	66 (30)
CNVM1H-6105Y-EP	1.5 x 4 (1.1 x 4)	6.16 (156)	18.27 (464)		□6.57 (□167)	64 (29)	21.00 (534)	6.56 (167)	□6.57 (□167)	5.04 (128)	4.61 (117)	75 (34)
CNVM2-6105Y-EP	2 x 4 (1.5 x 4)				67 (31)	78 (36)						
CNVM3-6105Y-EP	3 x 4 (2.2 x 4)	6.71 (170)	19.09 (485)	4.53 (115)	□7.24 (□184)	83 (38)	22.17 (563)	7.60 (193)	□7.24 (□184)	5.43 (138)	5.04 (128)	100 (45)
CNVM05-6115Y	1/2 x 4 (0.4 x 4)	4.63 (118)	14.25 (362)	2.32 (59)	ø4.88 (ø124)	43 (20)	15.51 (394)	3.58 (91)	ø4.88 (ø124)	2.40 (61)	-	46 (21)
CNVM05-6115Y-AV		5.67 (144)	15.87 (403)	3.82 (97)	ø5.94 (ø151)	49 (23)	17.56 (446)	5.51 (140)	ø5.94 (ø151)	3.66 (93)	3.94 (100)	55 (25)
CNVM08-6115Y	3/4 x 4 (0.55 x 4)					47 (21)						52 (24)
CNVM08-6115Y-AV		5.86 (149)	17.17 (436)	3.94 (100)	ø6.30 (ø160)	56 (26)	19.61 (498)	6.38 (162)	ø6.30 (ø160)	4.53 (115)	4.29 (109)	66 (30)
CNVM1-6115Y-EP	1 x 4 (0.75 x 4)	5.98 (152)	17.60 (447)	3.82 (97)	□6.22 (□158)	61 (28)	20.10 (511)	6.32 (161)	□6.22 (□158)	4.80 (122)	4.25 (108)	70 (32)
CNVM1H-6115Y-EP	1.5 x 4 (1.1 x 4)	6.16 (156)	18.66 (474)		□6.57 (□167)	68 (31)	21.40 (544)	6.56 (167)	□6.57 (□167)	5.04 (128)	4.61 (117)	79 (36)
CNVM2-6115Y-EP	2 x 4 (1.5 x 4)				71 (32)	82 (38)						
CNVM3-6115Y-EP	3 x 4 (2.2 x 4)	6.71 (170)	18.54 (471)	4.53 (115)	□7.24 (□184)	83 (38)	21.61 (549)	7.60 (193)	□7.24 (□184)	5.43 (138)	5.04 (128)	100 (45)
CNVM5-6115Y-EP	5 x 4 (3.7 x 4)	7.34 (186)	19.61 (498)	4.65 (118)	□8.74 (□222)	108 (49)	23.17 (589)	8.21 (209)	□8.74 (□222)	6.02 (153)	6.30 (160)	132 (60)

Note: [1] MP Dimension Symbol ø = Round Fan Cover
MP Dimension Symbol □ = Square Fan Cover

Dimensions Integral Universal V-Flange Mount

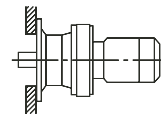

CNVM01-6125DBY ▶ CNVM8-6125Y-EP

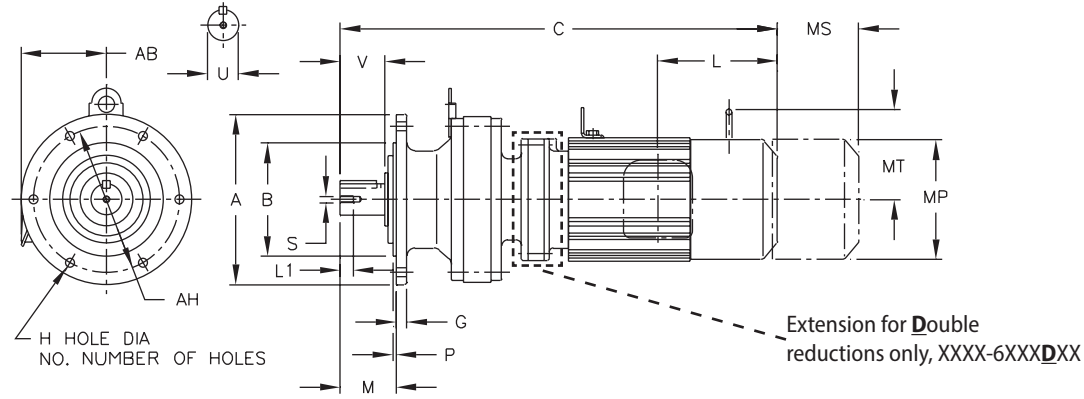

Table 1: Shaft Tolerances All dimensions are in inches (mm)

Low Speed Shaft Nominal Diameter	Tolerance Inches
0.500 through 0.625 (12.700 through 15.875)	+0.0000 / -0.0004 (+0.000 / -0.011)
0.750 through 1.125 (19.050 through 28.757)	+0.0000 / -0.0005 (+0.000 / -0.013)
1.250 through 1.875 (31.750 through 47.625)	+0.0000 / -0.0006 (+0.000 / -0.016)
2.000 through 3.125 (50.800 through 79.375)	+0.0000 / -0.0007 (+0.000 / -0.019)
3.250 through 4.625 (82.550 through 117.475)	+0.0000 / -0.0009 (+0.000 / -0.022)
4.750 through 7.000 (120.650 through 177.800)	+0.0000 / -0.0010 (+0.000 / -0.025)

Note: CNVM units are greased for life, and can be mounted in any position.

Dimensions are in inches (mm)

Model CNVM	A	B	G	H	NO.	M	O	P	AH
6120Y 6125Y	8.27 (210)	5.51 (140)	0.51 (13)	0.43 (11)	6	2.72 (69)	5.39 (137)	0.16 (4)	7.09 (180)

All dimensions are in inches (mm)

Model CNVM	Low Speed Shaft				
	U ^[A]	V	S	L1	Key
6120Y 6125Y	1.50 (38.1)	2.17 (55)	5/16-18UNC	0.79 (20)	3/8 x 3/8 x 1.77 (9.525 x 9.525 x 45)

Note: [A] Toleranced dimension, please refer to Table 1 above.

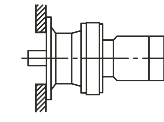

Dimensions Integral Universal V-Flange Mount

CNVM01-6125DBY ▶ CNVM8-6125Y-EP

XXXX-6XX0/6XX5 Frame sizes have equal dimensions, different ratings.

All dimensions are in inches (mm), lbs (kg)

Model	HP x P (kW x P)	AB	Without Brake				With Brake						
			C	ML	MP ^[1]	Weight lb (kg)	C	ML	MP ^[1]	MS	MT	Weight lb (kg)	
CNVM01-6125DBY	1/8 x 4 (0.1 x 4)	4.63 (118)	15.20 (386)	1.38 (35)	ø4.69 (ø119)	70 (32)	16.57 (421)	2.76 (70)	ø4.88 (ø124)	2.40 (61)	-	74 (34)	
CNVM01-6125DBY-AV			16.85 (428)			72 (33)	18.11 (460)					75 (34)	
CNVM02-6125DAY	1/4 x 4 (0.2 x 4)		16.38 (416)			65 (30)	17.64 (448)					68 (31)	
CNVM02-6125DBY				16.85 (428)			72 (33)	18.11 (460)					75 (34)
CNVM02-6125DAY-AV				17.17 (436)	2.32 (59)	ø4.88 (ø124)	68 (31)	18.43 (468)					71 (33)
CNVM02-6125DBY-AV				17.64 (448)			75 (34)	18.90 (480)					78 (36)
CNVM03-6125DBY			1/3 x 4 (0.25 x 4)	16.85 (428)			72 (33)	18.11 (460)					75 (34)
CNVM03-6125DBY-AV					17.64 (448)			75 (34)				18.90 (480)	
CNVM05-6125Y	1/2 x 4 (0.4 x 4)		15.24 (387)			64 (29)	16.50 (419)					67 (31)	
CNVM05-6125Y-AV			5.67 (144)	16.65 (423)	3.82 (97)	ø5.94 (ø151)	71 (33)	18.35 (466)				5.51 (140)	ø5.94 (ø151)
CNVM05-6125DBY		4.63 (118)	17.64 (448)	2.32 (59)	ø4.88 (ø124)	75 (34)	18.90 (480)	3.58 (91)	ø4.88 (ø124)	2.40 (61)	-	78 (36)	
CNVM05-6125DBY-AV			19.25 (489)			83 (38)	20.94 (532)		88 (40)				
CNVM08-6125Y	3/4 x 4 (0.55 x 4)	16.65 (423)			69 (31)	18.35 (466)		75 (34)					
CNVM08-6125Y-AV		5.86 (149)	17.95 (456)	3.94 (100)	ø6.30 (ø160)	77 (35)	20.39 (518)	6.38 (162)	ø6.30 (ø160)	4.53 (115)	4.29 (109)	88 (40)	
CNVM08-6125DBY		5.67 (144)	19.25 (489)	3.82 (97)	ø5.94 (ø151)	80 (37)	20.94 (532)	5.51 (140)	ø5.94 (ø151)	3.66 (93)	3.94 (100)	86 (39)	
CNVM08-6125DBY-AV		5.86 (149)	20.55 (522)	3.94 (100)	ø6.30 (ø160)	91 (41)	22.99 (584)	6.38 (162)	ø6.30 (ø160)	4.53 (115)	4.29 (109)	102 (46)	
CNVM1-6125Y-EP		1 x 4 (0.75 x 4)	18.39 (467)			82 (37)	20.89 (531)		92 (42)				
CNVM1-6125DBY-EP			5.98 (152)	20.98 (533)		□6.22 (□158)	96 (44)	23.48 (597)	6.32 (161)	□6.22 (□158)	4.80 (122)	4.25 (108)	106 (48)
CNVM1H-6125Y-EP	1.5 x 4 (1.1 x 4)	19.45 (494)			89 (41)	22.19 (564)		100 (46)					
CNVM1H-6125DBY-EP		6.16 (156)	22.05 (560)	3.82 (97)	□6.57 (□167)	103 (47)	24.78 (630)	6.56 (167)	□6.57 (□167)	5.04 (128)	4.61 (117)	115 (52)	
CNVM2-6125Y-EP		2 x 4 (1.5 x 4)	19.45 (494)			92 (42)	22.19 (564)		103 (47)				
CNVM2-6125DBY-EP			22.05 (560)			106 (48)	24.78 (630)		118 (54)				
CNVM3-6125Y-EP	3 x 4 (2.2 x 4)	6.71 (170)	18.86 (479)	4.53 (115)	□7.24 (□184)	105 (48)	21.93 (557)	7.60 (193)	□7.24 (□184)	5.43 (138)	5.04 (128)	122 (55)	
CNVM5-6125Y-EP	5 x 4 (3.7 x 4)	7.34 (186)	20.31 (516)	4.65 (118)	□8.74 (□222)	130 (59)	23.88 (607)	8.21 (209)	□8.74 (□222)	6.02 (153)	6.30 (160)	154 (70)	
CNVM8-6125Y-EP			22.01 (559)			164 (75)	25.57 (650)					188 (86)	

Note: [1] MP Dimension Symbol ø = Round Fan Cover
MP Dimension Symbol □ = Square Fan Cover

Dimensions Integral Vertical V-Flange Mount

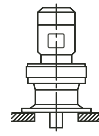

CVVM02-6135DAY ▶ CVVM15-6135Y-EP

Table 1: Shaft Tolerances

All dimensions are in inches (mm)

Low Speed Shaft Nominal Diameter	Tolerance
0.500 through 0.625 (12.700 through 15.875)	+0.0000 / -0.0004 (+0.000 / -0.011)
0.750 through 1.125 (19.050 through 28.757)	+0.0000 / -0.0005 (+0.000 / -0.013)
1.250 through 1.875 (31.750 through 47.625)	+0.0000 / -0.0006 (+0.000 / -0.016)
2.000 through 3.125 (50.800 through 79.375)	+0.0000 / -0.0007 (+0.000 / -0.019)
3.250 through 4.625 (82.550 through 117.475)	+0.0000 / -0.0009 (+0.000 / -0.022)
4.750 through 7.000 (120.650 through 177.800)	+0.0000 / -0.0010 (+0.000 / -0.025)

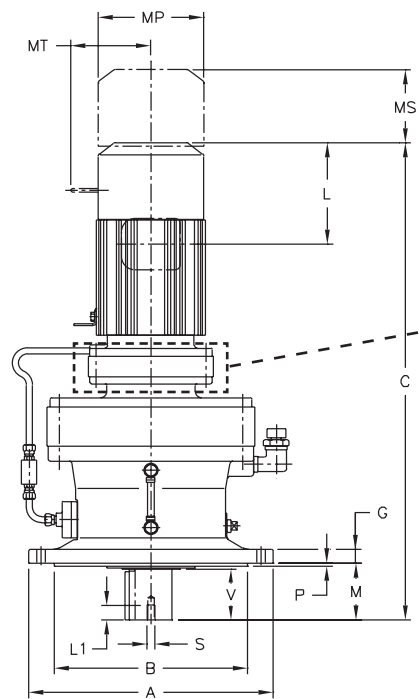

Extension for Double reductions only, XXXX-6XXXDXX

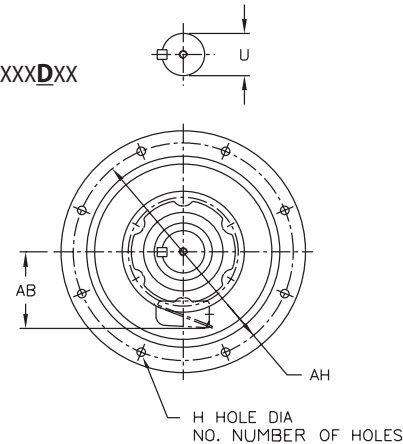

Note: CVVM units are oil lubricated standard, must be installed as shown above.

Dimensions are in inches (mm)

Model CVVM	A	B	G	H	NO.	M	O	P	AH
6130Y 6135Y	10.24 (260)	7.87 (200)	0.59 (15)	0.43 (11)	6	2.99 (76)	-	0.16 (4)	9.06 (230)

All dimensions are in inches (mm)

Model CVVM	Low Speed Shaft				
	U*	V	S	L1	Key
6130Y 6135Y	1.88 (47.625)	2.40 (61)	3/8-16UNC	0.79 (20)	1/2 x 1/2 x 2.17 (12.7 x 12.7 x 55)

Note: [A] Toleranced dimension, please refer to Table 1 above.

Dimensions Integral Vertical V-Flange Mount

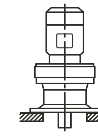

CVVM02-6135DAY ▶ CVVM15-6135Y-EP

XXXX-6XX0/6XX5 Frame sizes have equal dimensions, different ratings.

All dimensions are in inches (mm), lbs (kg)

Model	HP x P (kW x P)	AB	Without Brake				With Brake					
			C	ML	MP ^[1]	Weight lb (kg)	C	ML	MP ^[1]	MS	MT	Weight lb (kg)
CVVM02-6135DAY			18.50 (470)			98 (45)	19.76 (502)					101 (46)
CVVM02-6135DAY-AV	1/4 x 4 (0.2 x 4)		19.29 (490)			101 (46)	20.55 (522)					104 (48)
CVVM02-6135DCY			19.41 (493)			106 (48)	20.67 (525)					109 (50)
CVVM02-6135DCY-AV		4.63 (118)	20.20 (513)	2.32 (59)	ø4.88 (ø124)	109 (50)	21.46 (545)	3.58 (91)	ø4.88 (ø124)	2.40 (61)	-	112 (51)
CVVM03-6135DCY	1/3 x 4 (0.25 x 4)		19.41 (493)			106 (48)	20.67 (525)					109 (50)
CVVM03-6135DCY-AV			20.20 (513)			109 (50)	21.46 (545)					112 (51)
CVVM05-6135DCY	1/2 x 4 (0.4 x 4)		20.20 (513)			109 (50)	21.46 (545)					112 (51)
CVVM05-6135DCY-AV		5.67 (144)	21.81 (554)	3.82 (97)	ø5.94 (ø151)	116 (53)	23.50 (597)	5.51 (140)	ø5.94 (ø151)	3.66 (93)	3.94 (100)	122 (56)
CVVM08-6135Y			18.78 (477)			112 (51)	20.47 (520)					118 (54)
CVVM08-6135Y-AV		5.86 (149)	20.08 (510)	3.94 (100)	ø6.30 (ø160)	121 (55)	22.52 (572)	6.38 (162)	ø6.30 (ø160)	4.53 (115)	4.29 (109)	131 (60)
CVVM08-6135DCY	3/4 x 4 (0.55 x 4)		5.67 (144)	21.81 (554)	3.82 (97)	ø5.94 (ø151)	113 (52)	23.50 (597)	5.51 (140)	ø5.94 (ø151)	3.66 (93)	3.94 (100)
CVVM08-6135DCY-AV		5.86 (149)	23.11 (587)	3.94 (100)	ø6.30 (ø160)	124 (57)	25.55 (649)	6.38 (162)	ø6.30 (ø160)	4.53 (115)	4.29 (109)	135 (61)
CVVM1-6135Y-EP	1 x 4 (0.75 x 4)	5.98 (152)	20.51 (521)			125 (57)	23.01 (585)					135 (62)
CVVM1-6135DCY-EP			23.54 (598)			129 (59)	26.04 (662)	6.32 (161)	□6.22 (□158)	4.80 (122)	4.25 (108)	139 (63)
CVVM1H-6135Y-EP	1.5 x 4 (1.1 x 4)		21.57 (548)			132 (60)	24.31 (618)					144 (65)
CVVM1H-6135DCY-EP		6.16 (156)	24.61 (625)	3.82 (97)		137 (62)	27.34 (695)	6.56 (167)	□6.57 (□167)	5.04 (128)	4.61 (117)	148 (67)
CVVM2-6135Y-EP	2 x 4 (1.5 x 4)		21.57 (548)			135 (62)	24.31 (618)					147 (67)
CVVM2-6135DCY-EP			24.61 (625)			139 (64)	27.34 (695)					151 (69)
CVVM3-6135Y-EP	3 x 4 (2.2 x 4)	6.71 (170)	20.98 (533)	4.53 (115)	□7.24 (□184)	147 (67)	24.06 (611)	7.60 (193)	□7.24 (□184)	5.43 (138)	5.04 (128)	163 (74)
CVVM3-6135DCY-EP			25.43 (646)			156 (71)	28.50 (724)					172 (78)
CVVM5-6135Y-EP	5 x 4 (3.7 x 4)	7.34 (186)	22.24 (565)	4.65 (118)	□8.74 (□222)	171 (78)	25.81 (656)	8.21 (209)	□8.74 (□222)	6.02 (153)	6.30 (160)	195 (89)
CVVM8-6135Y-EP	7.5 x 4 (5.5 x 4)		23.94 (608)			205 (93)	27.50 (699)					229 (104)
CVVM10-6135Y-EP	10 x 4 (7.5 x 4)		25.43 (646)	5.43 (138)	□10.24 (□260)	232 (105)	29.57 (751)	9.57 (243)	□10.24 (□260)	7.44 (189)	7.32 (186)	276 (125)
CVVM15-6135Y-EP	15 x 4 (11 x 4)	9.04 (230)	27.87 (708)			244 (111)	32.01 (813)					289 (131)

Note: [1] MP Dimension Symbol ø = Round Fan Cover
MP Dimension Symbol □ = Square Fan Cover

Dimensions Integral Vertical V-Flange Mount

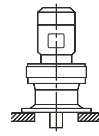

CVVM02-6145DBY ▶ CVVM20-6145Y-EP

Table 1: Shaft Tolerances

All dimensions are in inches (mm)

Low Speed Shaft Nominal Diameter	Tolerance
0.500 through 0.625 (12.700 through 15.875)	+0.0000 / -0.0004 (+0.000 / -0.011)
0.750 through 1.125 (19.050 through 28.757)	+0.0000 / -0.0005 (+0.000 / -0.013)
1.250 through 1.875 (31.750 through 47.625)	+0.0000 / -0.0006 (+0.000 / -0.016)
2.000 through 3.125 (50.800 through 79.375)	+0.0000 / -0.0007 (+0.000 / -0.019)
3.250 through 4.625 (82.550 through 117.475)	+0.0000 / -0.0009 (+0.000 / -0.022)
4.750 through 7.000 (120.650 through 177.800)	+0.0000 / -0.0010 (+0.000 / -0.025)

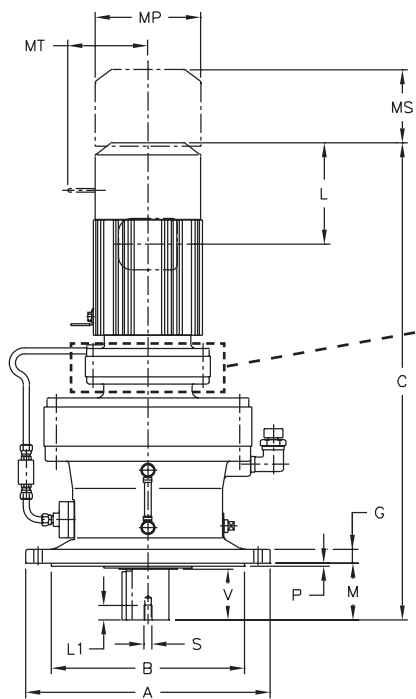

Extension for **Double** reductions only, XXXX-6XXXDXX

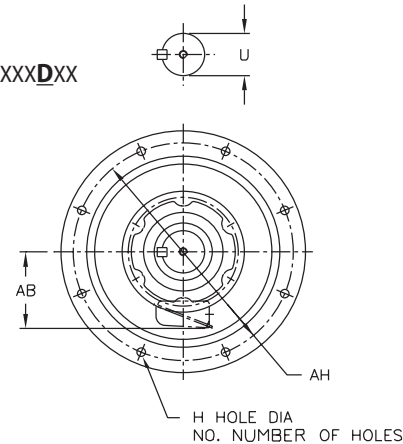

Note: CVVM units are oil lubricated standard, must be installed as shown above.

Dimensions are in inches (mm)

Model CVVM	A	B	G	H	NO.	M	O	P	AH
6140Y 6145Y	10.24 (260)	7.87 (200)	0.59 (15)	0.43 (11)	6	3.78 (96)	-	0.16 (4)	9.06 (230)

All dimensions are in inches (mm)

Model CVVM	Low Speed Shaft				
	U*	V	S	L1	Key
6140Y 6145Y	1.88 (47.625)	3.19 (81)	3/8-16UNC	0.79 (20)	1/2 x 1/2 x 2.95 (12.7 x 12.7 x 75)

Note: [A] Toleranced dimension, please refer to Table 1 above.

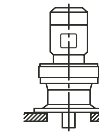

Dimensions Integral Vertical V-Flange Mount

CVVM02-6145DBY ▶ CVVM20-6145Y-EP

XXXX-6XX0/6XX5 Frame sizes have equal dimensions, different ratings.

All dimensions are in inches (mm), lbs (kg)

Model	HP x P (kW x P)	AB	Without Brake				With Brake					
			C	ML	MP ^[1]	Weight lb (kg)	C	ML	MP ^[1]	MS	MT	Weight lb (kg)
CVVM02-6145DBY	1/4 x 4 (0.2 x 4)	4.63 (118)	19.65 (499)	2.32 (59)	ø4.88 (ø124)	103 (47)	20.91 (531)	3.58 (91)	ø4.88 (ø124)	2.40 (61)	-	106 (48)
CVVM02-6145DBY-AV	20.43 (519)		106 (48)			21.69 (551)	109 (50)					
CVVM03-6145DBY	1/3 x 4 (0.25 x 4)	4.63 (118)	19.65 (499)	2.32 (59)	ø4.88 (ø124)	103 (47)	20.91 (531)	3.58 (91)	ø4.88 (ø124)	2.40 (61)	-	106 (48)
CVVM03-6145DBY-AV	20.43 (519)		106 (48)			21.69 (551)	109 (50)					
CVVM05-6145DBY	1/2 x 4 (0.4 x 4)	5.67 (144)	22.05 (560)	3.82 (97)	ø5.94 (ø151)	113 (52)	23.74 (603)	5.51 (140)	ø5.94 (ø151)	3.66 (93)	3.94 (100)	119 (54)
CVVM05-6145DBY-AV	111 (51)		111 (51)			117 (53)						
CVVM08-6145DBY	3/4 x 4 (0.55 x 4)	5.86 (149)	23.35 (593)	3.94 (100)	ø6.30 (ø160)	122 (55)	25.79 (655)	6.38 (162)	ø6.30 (ø160)	4.53 (115)	4.29 (109)	132 (60)
CVVM08-6145DBY-AV	23.35 (593)		122 (55)			25.79 (655)	132 (60)					
CVVM1-6145Y-EP	1 x 4 (0.75 x 4)	5.98 (152)	21.30 (541)	3.82 (97)	ø6.22 (ø158)	127 (58)	23.80 (605)	6.32 (161)	ø6.22 (ø158)	4.80 (122)	4.25 (108)	137 (63)
CVVM1-6145DBY-EP	23.78 (604)		127 (58)			26.28 (668)	136 (62)					
CVVM1H-6145Y-EP	1.5 x 4 (1.1 x 4)	6.16 (156)	22.36 (568)	3.82 (97)	ø6.57 (ø167)	134 (61)	25.10 (638)	6.56 (167)	ø6.57 (ø167)	5.04 (128)	4.61 (117)	146 (66)
CVVM1H-6145DBY-EP	24.84 (631)		134 (61)			27.58 (701)	149 (68)					
CVVM2-6145Y-EP	2 x 4 (1.5 x 4)	6.16 (156)	22.36 (568)	3.82 (97)	ø6.57 (ø167)	137 (63)	25.10 (638)	6.56 (167)	ø6.57 (ø167)	5.04 (128)	4.61 (117)	149 (68)
CVVM2-6145DBY-EP			24.84 (631)			137 (62)	27.58 (701)					151 (69)
CVVM2-6145DCY-EP			25.39 (645)			139 (64)	28.13 (715)					151 (69)
CVVM3-6145Y-EP	3 x 4 (2.2 x 4)	6.71 (170)	21.77 (553)	4.53 (115)	ø7.24 (ø184)	149 (68)	24.84 (631)	7.60 (193)	ø7.24 (ø184)	5.43 (138)	5.04 (128)	165 (75)
CVVM3-6145DBY-EP			25.67 (652)			153 (70)	28.74 (730)					170 (77)
CVVM3-6145DCY-EP			26.22 (666)			156 (71)	29.29 (744)					172 (78)
CVVM5-6145Y-EP	5 x 4 (3.7 x 4)	7.34 (186)	23.03 (585)	4.65 (118)	ø8.74 (ø222)	173 (79)	26.59 (676)	8.21 (209)	ø8.74 (ø222)	6.02 (153)	6.30 (160)	197 (90)
CVVM8-6145Y-EP	7.5 x 4 (5.5 x 4)		24.72 (628)			207 (94)	28.29 (719)					231 (105)
CVVM10-6145Y-EP	10 x 4 (7.5 x 4)	9.04 (230)	26.22 (666)	5.43 (138)	ø10.24 (ø260)	234 (106)	30.35 (771)	9.57 (243)	ø10.24 (ø260)	7.44 (189)	7.32 (186)	278 (126)
CVVM15-6145Y-EP	15 x 4 (11 x 4)		28.66 (728)			247 (112)	32.80 (833)					291 (132)
CVVM20-6145Y-EP	20 x 4 (15 x 4)	10.26 (261)	31.10 (790)	7.01 (178)	ø12.49 (ø317)	327 (149)	36.40 (925)	12.30 (313)	ø12.61 (ø320)	9.53 (242)	-	413 (188)

Note: [1] MP Dimension Symbol ø = Round Fan Cover
MP Dimension Symbol □ = Square Fan Cover

Dimensions Integral Vertical V-Flange Mount

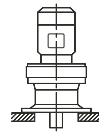

CVVM05-6165DCY ▶ CVVM30-6165Y-EP

Table 1: Shaft Tolerances

All dimensions are in inches (mm)

Low Speed Shaft Nominal Diameter	Tolerance
0.500 through 0.625 (12.700 through 15.875)	+0.0000 / -0.0004 (+0.000 / -0.011)
0.750 through 1.125 (19.050 through 28.757)	+0.0000 / -0.0005 (+0.000 / -0.013)
1.250 through 1.875 (31.750 through 47.625)	+0.0000 / -0.0006 (+0.000 / -0.016)
2.000 through 3.125 (50.800 through 79.375)	+0.0000 / -0.0007 (+0.000 / -0.019)
3.250 through 4.625 (82.550 through 117.475)	+0.0000 / -0.0009 (+0.000 / -0.022)
4.750 through 7.000 (120.650 through 177.800)	+0.0000 / -0.0010 (+0.000 / -0.025)

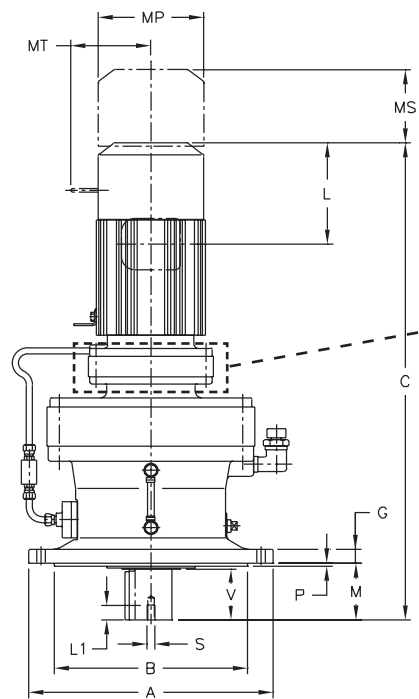

Extension for Double reductions only, XXXX-6XXXDXX

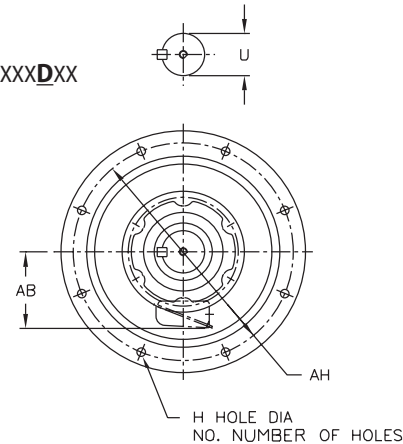

Note: CVVM units are oil lubricated standard, must be installed as shown above.

Dimensions are in inches (mm)

Model CVVM	A	B	G	H	NO.	M	O	P	AH
6160Y 6165Y	13.39 (340)	10.63 (270)	0.79 (20)	0.43 (11)	6	3.50 (89)	-	0.16 (4)	12.20 (310)

All dimensions are in inches (mm)

Model CVVM	Low Speed Shaft				Key
	U*	V	S	L1	
6160Y 6165Y	2.25 (57.15)	3.19 (81)	3/8-16UNC	0.79 (20)	1/2 x 1/2 x 2.95 (12.7 x 12.7 x 75)

Note: [A] Toleranced dimension, please refer to Table 1 above.

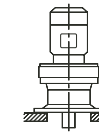

Dimensions Integral Vertical V-Flange Mount

CVVM05-6165DCY ▶ CVVM30-6165Y-EP

XXXX-6XX0/6XX5 Frame sizes have equal dimensions, different ratings.

All dimensions are in inches (mm), lbs (kg)

Model	HP x P (kW x P)	AB	Without Brake				With Brake						
			C	ML	MP ^[1]	Weight lb (kg)	C	ML	MP ^[1]	MS	MT	Weight lb (kg)	
CVVM05-6165DCY	1/2 x 4 (0.4 x 4)	4.63 (118)	23.23 (590)	2.32 (59)	ø4.88 (ø124)	212 (96)	24.49 (622)	3.58 (91)	ø4.88 (ø124)	2.40 (61)	-	215 (98)	
CVVM05-6165DCY-AV		5.67 (144)	24.65 (626)	3.82 (97)	ø5.94 (ø151)	219 (100)	26.34 (669)	5.51 (140)	ø5.94 (ø151)	3.66 (93)	3.94 (100)	225 (102)	
CVVM08-6165DCY	3/4 x 4 (0.55 x 4)	5.86 (149)	25.94 (659)	3.94 (100)	ø6.30 (ø160)	216 (98)						236 (107)	
CVVM08-6165DCY-AV		5.98 (152)	26.38 (670)		ø6.22 (ø158)	225 (102)	28.88 (734)	6.32 (161)	ø6.22 (ø158)	4.53 (115)	4.29 (109)	240 (109)	
CVVM1-6165DCY-EP	1 x 4 (0.75 x 4)				230 (104)	28.88 (734)						6.32 (161)	4.80 (122)
CVVM1H-6165Y-EP	1.5 x 4 (1.1 x 4)	6.16 (156)	24.25 (616)	3.82 (97)	ø6.57 (ø167)	208 (94)	26.99 (686)	6.56 (167)	ø6.57 (ø167)	5.04 (128)	4.61 (117)	219 (100)	
CVVM1H-6165DCY-EP			27.44 (697)			237 (108)						30.18 (767)	248 (113)
CVVM2-6165Y-EP	2 x 4 (1.5 x 4)		24.25 (616)			211 (96)						26.99 (686)	222 (101)
CVVM2-6165DCY-EP			27.44 (697)			240 (109)						30.18 (767)	251 (114)
CVVM3-6165Y-EP	3 x 4 (2.2 x 4)	6.71 (170)	23.66 (601)	4.53 (115)	ø7.24 (ø184)	221 (100)	26.73 (679)	7.60 (193)	ø7.24 (ø184)	5.43 (138)	5.04 (128)	237 (108)	
CVVM3-6165DCY-EP			26.85 (682)			253 (115)						29.92 (760)	269 (122)
CVVM5-6165Y-EP	5 x 4 (3.7 x 4)	7.34 (186)	25.12 (638)	4.65 (118)	ø8.74 (ø222)	246 (112)	28.68 (729)	8.21 (209)	ø8.74 (ø222)	6.02 (153)	6.30 (160)	302 (137)	
CVVM5-6165DCY-EP			28.31 (719)			278 (126)						31.87 (810)	303 (138)
CVVM8-6165Y-EP	7.5 x 4 (5.5 x 4)		26.81 (681)			279 (127)						30.37 (772)	303 (138)
CVVM8-6165DCY-EP			30.00 (762)			312 (142)						33.56 (853)	336 (153)
CVVM10-6165Y-EP	10 x 4 (7.5 x 4)	9.04 (230)	28.27 (718)	5.43 (138)	ø10.24 (ø260)	307 (140)	32.40 (823)	9.57 (243)	ø10.24 (ø260)	7.44 (189)	7.32 (186)	352 (160)	
CVVM15-6165Y-EP	15 x 4 (11 x 4)		30.71 (780)			320 (145)						34.84 (885)	364 (165)
CVVM20-6165Y-EP	20 x 4 (15 x 4)	10.26 (261)	32.99 (838)	7.01 (178)	ø12.49 (ø317)	403 (183)	38.29 (973)	12.30 (313)	ø12.61 (ø320)	9.53 (242)	-	489 (222)	
CVVM25-6165Y-EP	25 x 4 (18.5 x 4)	13.39 (340)	37.17 (944)	9.06 (230)	ø15.12 (ø384)	681 (309)	44.02 (1118)	15.91 (404)	ø15.28 (ø388)	12.13 (308)	-	778 (353)	
CVVM30-6165Y-EP	30 x 4 (22 x 4)												

Note: [1] MP Dimension Symbol ø = Round Fan Cover
MP Dimension Symbol □ = Square Fan Cover

Dimensions Integral Vertical V-Flange Mount

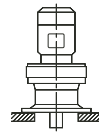

CVVM05-6175DCY ▶ CVVM40-6175Y-EP

Table 1: Shaft Tolerances

All dimensions are in inches (mm)

Low Speed Shaft Nominal Diameter	Tolerance
0.500 through 0.625 (12.700 through 15.875)	+0.0000 / -0.0004 (+0.000 / -0.011)
0.750 through 1.125 (19.050 through 28.757)	+0.0000 / -0.0005 (+0.000 / -0.013)
1.250 through 1.875 (31.750 through 47.625)	+0.0000 / -0.0006 (+0.000 / -0.016)
2.000 through 3.125 (50.800 through 79.375)	+0.0000 / -0.0007 (+0.000 / -0.019)
3.250 through 4.625 (82.550 through 117.475)	+0.0000 / -0.0009 (+0.000 / -0.022)
4.750 through 7.000 (120.650 through 177.800)	+0.0000 / -0.0010 (+0.000 / -0.025)

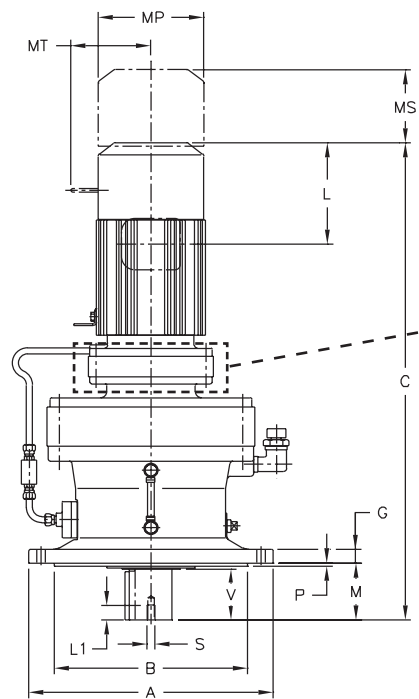

Extension for Double reductions only, XXXX-6XXXDXX

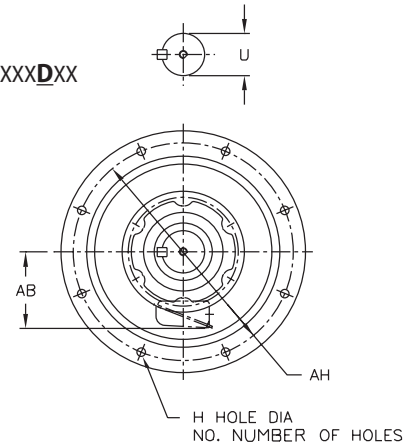

Note: CVVM units are oil lubricated standard, must be installed as shown above.

Dimensions are in inches (mm)

Model CVVM	A	B	G	H	NO.	M	O	P	AH
6170Y 6175Y	15.75 (400)	12.44 (316)	0.87 (22)	0.55 (14)	8	3.70 (94)	-	0.20 (5)	14.17 (360)

All dimensions are in inches (mm)

Model CVVM	Low Speed Shaft				Key
	U*	V	S	L1	
6170Y 6175Y	2.75 (69.85)	3.19 (81)	1/2-13UNC	0.94 (24)	5/8 x 5/8 x 3.15 (15.87 x 15.87 x 80)

Note: [A] Toleranced dimension, please refer to Table 1 above.

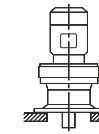

Dimensions Integral Vertical V-Flange Mount

CVVM05-6175DCY ▶ CVVM40-6175Y-EP

XXXX-6XX0/6XX5 Frame sizes have equal dimensions, different ratings.

All dimensions are in inches (mm), lbs (kg)

Model	HP x P (kW x P)	AB	Without Brake				With Brake							
			C	ML	MP ^[1]	Weight lb (kg)	C	ML	MP ^[1]	MS	MT	Weight lb (kg)		
CVVM05-6175DCY	1/2 x 4 (0.4 x 4)	4.63 (118)	25.08 (637)	2.32 (59)	ø4.88 (ø124)	289 (131)	26.34 (669)	3.58 (91)	ø4.88 (ø124)	2.40 (61)	-	292 (133)		
CVVM05-6175DCY-AV		5.67 (144)	26.50 (673)	3.82 (97)	ø5.94 (ø151)	296 (135)	28.19 (716)	5.51 (140)	ø5.94 (ø151)	3.66 (93)	3.94 (100)	302 (137)		
CVVM08-6175DCY	3/4 x 4 (0.55 x 4)	5.86 (149)	27.80 (706)	3.94 (100)	ø6.30 (ø160)	294 (133)						299 (136)		
CVVM08-6175DCY-AV		5.98 (152)	27.52 (699)	3.82 (97)	ø6.22 (ø158)	285 (130)	30.02 (763)	6.32 (161)	ø6.22 (ø158)	4.80 (122)	4.25 (108)	313 (142)		
CVVM1-6175DAY-EP	1 x 4 (0.75 x 4)	5.98 (152)	28.23 (717)			307 (139)						30.73 (781)	295 (134)	
CVVM1-6175DCY-EP		6.16 (156)	29.29 (744)	3.82 (97)	ø6.57 (ø167)	285 (130)	31.32 (796)	6.56 (167)	ø6.57 (ø167)	5.04 (128)	4.61 (117)	317 (144)		
CVVM1H-6175DCY-EP	1.5 x 4 (1.1 x 4)	6.16 (156)	28.58 (726)			314 (143)						32.03 (814)	325 (148)	
CVVM2-6175DAY-EP	2 x 4 (1.5 x 4)	6.16 (156)	29.29 (744)			296 (134)						31.32 (796)	307 (140)	
CVVM2-6175DCY-EP		6.71 (170)	28.70 (729)	4.53 (115)	ø7.24 (ø184)	317 (144)	32.03 (814)	7.60 (193)	ø7.24 (ø184)	5.43 (138)	5.04 (128)	328 (149)		
CVVM3-6175DCY-EP	3 x 4 (2.2 x 4)	6.71 (170)	28.70 (729)	4.53 (115)	ø7.24 (ø184)	330 (150)	31.77 (807)					7.60 (193)	ø7.24 (ø184)	5.43 (138)
CVVM5-6175Y-EP	5 x 4 (3.7 x 4)	7.34 (186)	27.05 (687)	4.65 (118)	ø8.74 (ø222)	351 (159)	30.61 (778)	8.21 (209)	ø8.74 (ø222)	6.02 (153)	6.30 (160)	375 (170)		
CVVM5-6175DCY-EP	5 x 4 (3.7 x 4)		30.16 (766)			355 (161)	33.72 (857)					379 (172)		
CVVM8-6175Y-EP	7.5 x 4 (5.5 x 4)	7.34 (186)	28.74 (730)			385 (175)	32.30 (821)					408 (186)		
CVVM8-6175DCY-EP	7.5 x 4 (5.5 x 4)	7.34 (186)	31.85 (809)			389 (177)	35.41 (900)					413 (188)		
CVVM10-6175Y-EP	10 x 4 (7.5 x 4)	9.04 (230)	29.57 (751)	5.43 (138)	ø10.24 (ø260)	413 (188)	33.70 (856)	9.57 (243)	ø10.24 (ø260)	7.44 (189)	7.32 (186)	458 (208)		
CVVM15-6175Y-EP	15 x 4 (11 x 4)		9.04 (230)			32.01 (813)	426 (194)					36.14 (918)	470 (214)	
CVVM20-6175Y-EP	20 x 4 (15 x 4)	10.26 (261)	34.72 (882)	7.01 (178)	ø12.49 (ø317)	507 (230)	40.02 (1017)	12.30 (313)	ø12.61 (ø320)	9.53 (242)	-	593 (269)		
CVVM25-6175Y-EP	25 x 4 (18.5 x 4)	13.39 (340)	38.90 (988)	9.06 (230)	ø15.12 (ø384)	786 (357)	45.75 (1162)	15.91 (404)	ø15.28 (ø388)	12.13 (308)	-	883 (401)		
CVVM30-6175Y-EP	30 x 4 (22 x 4)		38.90 (988)			9.06 (230)	ø15.12 (ø384)					786 (357)	45.75 (1162)	883 (401)
CVVM40-6175Y-EP	40 x 4 (30 x 4)		43.78 (1112)			43.78 (1112)	9.06 (230)					ø15.12 (ø384)	899 (408)	50.63 (1286)

Note: [1] MP Dimension Symbol ø = Round Fan Cover
MP Dimension Symbol □ = Square Fan Cover

Dimensions Integral Vertical V-Flange Mount

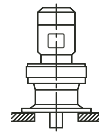

CVVM1-6185DBY-EP ▶ CVVM50-6185Y-EP

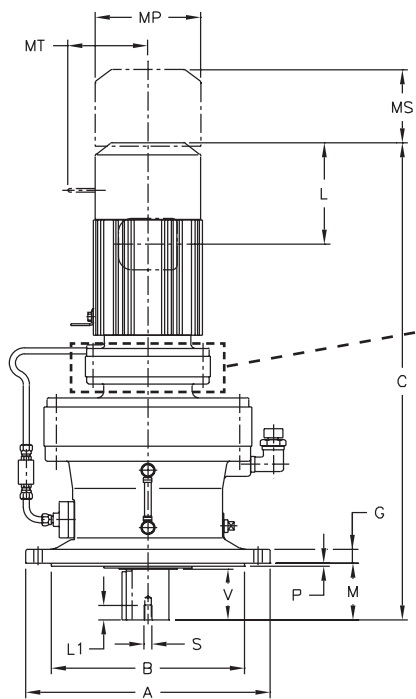
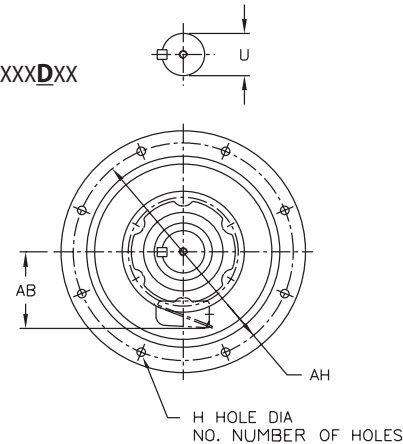

Table 1: Shaft Tolerances

All dimensions are in inches (mm)

Low Speed Shaft Nominal Diameter	Tolerance
0.500 through 0.625 (12.700 through 15.875)	+0.0000 / -0.0004 (+0.000 / -0.011)
0.750 through 1.125 (19.050 through 28.757)	+0.0000 / -0.0005 (+0.000 / -0.013)
1.250 through 1.875 (31.750 through 47.625)	+0.0000 / -0.0006 (+0.000 / -0.016)
2.000 through 3.125 (50.800 through 79.375)	+0.0000 / -0.0007 (+0.000 / -0.019)
3.250 through 4.625 (82.550 through 117.475)	+0.0000 / -0.0009 (+0.000 / -0.022)
4.750 through 7.000 (120.650 through 177.800)	+0.0000 / -0.0010 (+0.000 / -0.025)

Extension for Double reductions only, XXXX-6XXXDXX



Note: CVVM units are oil lubricated standard, must be installed as shown above.

Dimensions are in inches (mm)

Model CVVM	A	B	G	H	NO.	M	O	P	AH
6180Y 6185Y	16.93 (430)	13.58 (345)	0.87 (22)	0.71 (18)	8	4.33 (110)	-	0.20 (5)	15.35 (390)

All dimensions are in inches (mm)

Model CVVM	Low Speed Shaft				
	U*	V	S	L1	Key
6180Y 6185Y	3.13 (79.375)	3.94 (100)	1/2-13UNC	0.94 (24)	3/4 x 3/4 x 3.74 (19.05 x 19.05 x 95)

Note: [A] Toleranced dimension, please refer to Table 1 above.

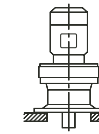

Dimensions Integral Vertical V-Flange Mount

CVVM1-6185DBY-EP ▶ CVVM50-6185Y-EP

XXXX-6XX0/6XX5 Frame sizes have equal dimensions, different ratings.

All dimensions are in inches (mm), lbs (kg)

Model	HP x P (kW x P)	AB	Without Brake				With Brake					
			C	ML	MP ^[1]	Weight lb (kg)	C	ML	MP ^[1]	MS	MT	Weight lb (kg)
CVVM1-6185DBY-EP	1 x 4 (0.75 x 4)	5.98 (152)	30.59 (777)	3.82 (97)	□6.22 (□158)	410 (186)	33.09 (841)	6.32 (161)	□6.22 (□158)	4.80 (122)	4.25 (108)	419 (191)
CVVM1H-6185DBY-EP	1.5 x 4 (1.1 x 4)	6.16 (156)	31.65 (804)		□6.57 (□167)	416 (189)	34.39 (874)	6.56 (167)	□6.57 (□167)	5.04 (128)	4.61 (117)	428 (194)
CVVM2-6185DAY-EP	2 x 4 (1.5 x 4)		30.79 (782)		371 (169)	33.52 (852)	382 (174)					
CVVM2-6185DBY-EP	2 x 4 (1.5 x 4)		31.65 (804)	419 (191)	34.39 (874)	431 (196)						
CVVM3-6185DBY-EP	3 x 4 (2.2 x 4)	6.71 (170)	31.06 (789)	4.53 (115)	□7.24 (□184)	431 (196)	34.13 (867)	7.60 (193)	□7.24 (□184)	5.43 (138)	5.04 (128)	448 (203)
CVVM5-6185Y-EP	5 x 4 (3.7 x 4)	7.34 (186)	28.50 (724)	4.65 (118)	□8.74 (□222)	403 (183)	32.07 (815)	8.21 (209)	□8.74 (□222)	6.02 (153)	6.30 (160)	426 (194)
CVVM5-6185DBY-EP	5 x 4 (3.7 x 4)		32.32 (821)			455 (207)	35.89 (912)					479 (218)
CVVM8-6185Y-EP	7.5 x 4 (5.5 x 4)		30.20 (767)			436 (198)	33.76 (858)					460 (209)
CVVM8-6185DBY-EP	7.5 x 4 (5.5 x 4)		34.02 (864)		489 (222)	37.58 (955)						513 (233)
CVVM10-6185Y-EP	10 x 4 (7.5 x 4)	9.04 (230)	31.14 (791)	5.43 (138)	□10.24 (□260)	467 (212)	35.28 (896)	9.57 (243)	□10.24 (□260)	7.44 (189)	7.32 (186)	511 (232)
CVVM10-6185DBY-EP	10 x 4 (7.5 x 4)		35.51 (902)			516 (234)	39.65 (1007)					560 (254)
CVVM15-6185Y-EP	15 x 4 (11 x 4)		33.58 (853)			480 (218)	37.72 (958)					524 (238)
CVVM15-6185DBY-EP	15 x 4 (11 x 4)		37.95 (964)		529 (240)	42.09 (1069)						573 (260)
CVVM20-6185Y-EP	20 x 4 (15 x 4)	10.26 (261)	36.18 (919)	7.01 (178)	∅12.49 (∅317)	559 (254)	41.48 (1054)	12.30 (313)	∅12.61 (∅320)	9.53 (242)		645 (293)
CVVM25-6185Y-EP	25 x 4 (18.5 x 4)	13.39 (340)	40.35 (1025)	9.06 (230)	∅15.12 (∅384)	836 (380)	47.20 (1199)	15.91 (404)	∅15.28 (∅388)	12.13 (308)		933 (424)
CVVM30-6185Y-EP	30 x 4 (22 x 4)					950 (431)	52.09 (1323)				1047 (475)	
CVVM40-6185Y-EP	40 x 4 (30 x 4)											
CVVM50-6185Y-EP	50 x 4 (37 x 4)		45.24 (1149)			1018 (462)	-	-	-	-		-

Note: [1] MP Dimension Symbol ∅ = Round Fan Cover
MP Dimension Symbol □ = Square Fan Cover

Dimensions Integral Vertical V-Flange Mount

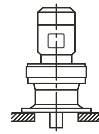

CVVM1-6195DAY-EP ▶ CVVM60-6195Y-EP

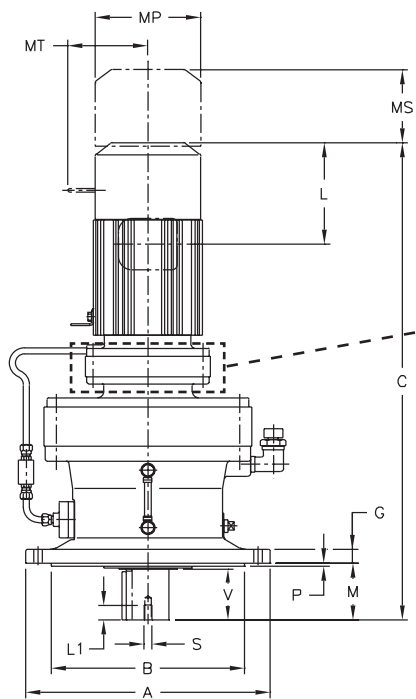

Extension for Double reductions only, XXXX-6XXXDXX

Table 1: Shaft Tolerances

All dimensions are in inches (mm)

Low Speed Shaft Nominal Diameter	Tolerance
0.500 through 0.625 (12.700 through 15.875)	+0.0000 / -0.0004 (+0.000 / -0.011)
0.750 through 1.125 (19.050 through 28.757)	+0.0000 / -0.0005 (+0.000 / -0.013)
1.250 through 1.875 (31.750 through 47.625)	+0.0000 / -0.0006 (+0.000 / -0.016)
2.000 through 3.125 (50.800 through 79.375)	+0.0000 / -0.0007 (+0.000 / -0.019)
3.250 through 4.625 (82.550 through 117.475)	+0.0000 / -0.0009 (+0.000 / -0.022)
4.750 through 7.000 (120.650 through 177.800)	+0.0000 / -0.0010 (+0.000 / -0.025)

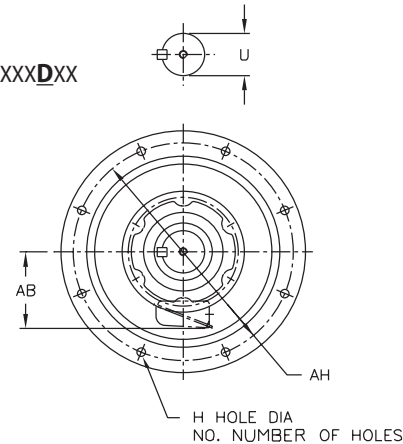

Note: CVVM units are oil lubricated standard, must be installed as shown above.

Dimensions are in inches (mm)

Model CVVM	A	B	G	H	NO.	M	O	P	AH
6190Y 6195Y	19.29 (490)	15.75 (400)	1.18 (30)	0.71 (18)	12	5.71 (145)	-	0.24 (6)	17.72 (450)

All dimensions are in inches (mm)

Model CVVM	Low Speed Shaft				
	U*	V	S	L1	Key
6190Y 6195Y	3.63 (92.075)	4.92 (125)	3/4-10UNC	1.34 (34)	7/8 x 7/8 x 4.92 (22.225 x 22.225 x 125)

Note: [A] Toleranced dimension, please refer to Table 1 above.

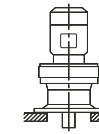

Dimensions Integral Vertical V-Flange Mount

CVVM1-6195DAY-EP ▶ CVVM60-6195Y-EP

XXXX-6XX0/6XX5 Frame sizes have equal dimensions, different ratings.

All dimensions are in inches (mm), lbs (kg)

Model	HP x P (kW x P)	AB	Without Brake				With Brake					
			C	ML	MP ^[1]	Weight lb (kg)	C	ML	MP ^[1]	MS	MT	Weight lb (kg)
CVVM1-6195DAY-EP	1 x 4 (0.75 x 4)	5.98 (152)	32.95 (837)	3.82 (97)	□6.22 (□158)	536 (243)	35.45 (901)	6.32 (161)	□6.22 (□158)	4.80 (122)	4.25 (108)	546 (248)
CVVM1H-6195DAY-EP	1.5 x 4 (1.1 x 4)	6.16 (156)	34.02 (864)		□6.57 (□167)	543 (247)	36.75 (934)	6.56 (167)	□6.57 (□167)	5.04 (128)	4.61 (117)	555 (252)
CVVM2-6195DAY-EP	2 x 4 (1.5 x 4)		6.71 (170)	33.43 (849)	4.53 (115)	□7.24 (□184)	559 (254)	36.50 (927)	7.60 (193)	□7.24 (□184)	5.43 (138)	5.04 (128)
CVVM3-6195DAY-EP	3 x 4 (2.2 x 4)	34.06 (865)		583 (265)		37.13 (943)	600 (272)					
CVVM3-6195DBY-EP	3 x 4 (2.2 x 4)	7.34 (186)	34.88 (886)	4.65 (118)	□8.74 (□222)	585 (265)	38.44 (977)	8.21 (209)	□8.74 (□222)	6.02 (153)	6.30 (160)	608 (276)
CVVM5-6195DAY-EP	5 x 4 (3.7 x 4)		35.31 (897)			607 (276)	38.88 (988)					631 (287)
CVVM5-6195DBY-EP	5 x 4 (3.7 x 4)	7.34 (186)	33.78 (858)	4.65 (118)	□8.74 (□222)	599 (272)	37.34 (949)	8.21 (209)	□8.74 (□222)	6.02 (153)	6.30 (160)	623 (283)
CVVM8-6195Y-EP	7.5 x 4 (5.5 x 4)		36.57 (929)			618 (281)	40.14 (1020)					642 (292)
CVVM8-6195DAY-EP	7.5 x 4 (5.5 x 4)	9.04 (230)	37.01 (940)	5.43 (138)	□10.24 (□260)	641 (291)	40.57 (1031)	9.57 (243)	□10.24 (□260)	7.44 (189)	7.32 (186)	665 (302)
CVVM8-6195DBY-EP	7.5 x 4 (5.5 x 4)		34.02 (864)			630 (286)	38.15 (969)					674 (306)
CVVM10-6195Y-EP	10 x 4 (7.5 x 4)	9.04 (230)	38.50 (978)	5.43 (138)	□10.24 (□260)	668 (303)	42.64 (1083)	9.57 (243)	□10.24 (□260)	7.44 (189)	7.32 (186)	712 (323)
CVVM10-6195DBY-EP	10 x 4 (7.5 x 4)		36.46 (926)			643 (292)	40.59 (1031)					687 (312)
CVVM15-6195Y-EP	15 x 4 (11 x 4)	10.26 (261)	40.94 (1040)	7.01 (178)	∅12.49 (∅317)	681 (309)	45.08 (1145)	12.30 (313)	∅12.61 (∅320)	9.53 (242)	-	725 (329)
CVVM15-6195DBY-EP	15 x 4 (11 x 4)		39.17 (995)			721 (327)	44.47 (1130)					807 (366)
CVVM20-6195Y-EP	20 x 4 (15 x 4)	13.39 (340)	43.39 (1102)	9.06 (230)	∅15.12 (∅384)	761 (346)	48.68 (1237)	15.91 (404)	∅15.28 (∅388)	12.13 (308)	-	847 (385)
CVVM20-6195DBY-EP	20 x 4 (15 x 4)		43.35 (1101)			999 (454)	50.20 (1275)					1096 (498)
CVVM25-6195Y-EP	25 x 4 (18.5 x 4)	16.33 (415)	49.69 (1262)	16.81 (427)	∅18.66 (∅474)	1112 (505)	55.08 (1399)	-	-	-	-	-
CVVM30-6195Y-EP	30 x 4 (22 x 4)											
CVVM40-6195Y-EP	40 x 4 (30 x 4)	16.33 (415)	49.69 (1262)	16.81 (427)	∅18.66 (∅474)	1309 (594)	-	-	-	-	-	-
CVVM50-6195Y-EP	50 x 4 (37 x 4)											
CVVM60-6195Y-EP	60 x 4 (45 x 4)	16.33 (415)	49.69 (1262)	16.81 (427)	∅18.66 (∅474)	1309 (594)	-	-	-	-	-	-

Note: [1] MP Dimension Symbol ∅ = Round Fan Cover
MP Dimension Symbol □ = Square Fan Cover

Dimensions Integral Vertical V-Flange Mount

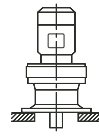

CVVM1-6205DAY-EP ▶ CVVM75-6205Y-EP

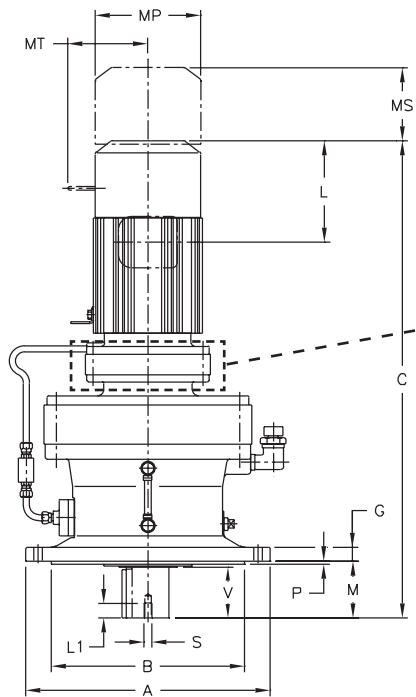

Extension for Double reductions only, XXXX-6XXXDXX

Table 1: Shaft Tolerances

All dimensions are in inches (mm)

Low Speed Shaft Nominal Diameter	Tolerance
0.500 through 0.625 (12.700 through 15.875)	+0.0000 / -0.0004 (+0.000 / -0.011)
0.750 through 1.125 (19.050 through 28.757)	+0.0000 / -0.0005 (+0.000 / -0.013)
1.250 through 1.875 (31.750 through 47.625)	+0.0000 / -0.0006 (+0.000 / -0.016)
2.000 through 3.125 (50.800 through 79.375)	+0.0000 / -0.0007 (+0.000 / -0.019)
3.250 through 4.625 (82.550 through 117.475)	+0.0000 / -0.0009 (+0.000 / -0.022)
4.750 through 7.000 (120.650 through 177.800)	+0.0000 / -0.0010 (+0.000 / -0.025)

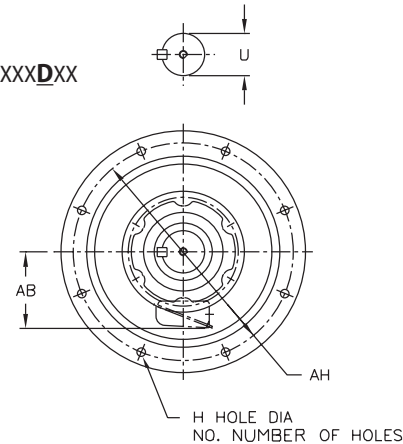

Note: CVVM units are oil lubricated standard, must be installed as shown above.

Dimensions are in inches (mm)

Model CVVM	A	B	G	H	NO.	M	O	P	AH
6205Y	17.91 (455)	13.98 (355)	1.18 (30)	0.87 (22)	8	8.03 (204)	-	0.20 (5)	15.94 (405)

All dimensions are in inches (mm)

Model CVVM	Low Speed Shaft				Key
	U*	V	S	L1	
6205Y	3.88 (98.425)	6.50 (165)	3/4-10UNC	1.34 (34)	1 x 1 x 6.5 (25.4 x 25.4 x 165)

Note: [A] Toleranced dimension, please refer to Table 1 above.

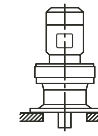

Dimensions Integral Vertical V-Flange Mount

CVVM1-6205DAY-EP ▶ CVVM75-6205Y-EP

XXXX-6XX0/6XX5 Frame sizes have equal dimensions, different ratings.

All dimensions are in inches (mm), lbs (kg)

Model	HP x P (kW x P)	AB	Without Brake				With Brake					
			C	ML	MP ^[1]	Weight lb (kg)	C	ML	MP ^[1]	MS	MT	Weight lb (kg)
CVVM1-6205DAY-EP	1 x 4 (0.75 x 4)	5.98 (152)	34.57 (878)	3.82 (97)	□6.22 (□158)	574 (260)	37.07 (942)	6.32 (161)	□6.22 (□158)	4.80 (122)	4.25 (108)	583 (265)
CVVM2-6205DAY-EP	2 x 4 (1.5 x 4)	6.16 (156)	35.63 (905)		□6.57 (□167)	584 (265)	38.37 (975)	6.56 (167)	□6.57 (□167)	5.04 (128)	4.61 (117)	595 (270)
CVVM3-6205DAY-EP	3 x 4 (2.2 x 4)	6.71 (170)	35.04 (890)	4.53 (115)	□7.24 (□184)	597 (271)	38.11 (968)	7.60 (193)	□7.24 (□184)	5.43 (138)	5.04 (128)	613 (278)
CVVM3-6205DBY-EP			36.10 (917)			623 (283)						39.17 (995)
CVVM5-6205DAY-EP	5 x 4 (3.7 x 4)	7.34 (186)	36.50 (927)	4.65 (118)	□8.74 (□222)	622 (282)	40.06 (1018)	8.21 (209)	□8.74 (□222)	6.02 (153)	6.30 (160)	646 (293)
CVVM5-6205DBY-EP			37.36 (949)			647 (294)						40.93 (1040)
CVVM8-6205DAY-EP	7.5 x 4 (5.5 x 4)	9.04 (230)	38.19 (970)	5.43 (138)	□10.24 (□260)	656 (298)	41.75 (1061)	9.57 (243)	□10.24 (□260)	7.44 (189)	7.32 (186)	680 (309)
CVVM8-6205DBY-EP			39.06 (992)			681 (309)						42.62 (1083)
CVVM10-6205DBY-EP	10 x 4 (7.5 x 4)	10.26 (261)	40.55 (1030)	7.01 (178)	□12.49 (□317)	708 (321)	44.69 (1135)	12.30 (313)	□12.61 (□320)	9.53 (242)		752 (341)
CVVM15-6205Y-EP	15 x 4 (11 x 4)	9.04 (230)	37.97 (965)			679 (308)						42.11 (1070)
CVVM15-6205DBY-EP	15 x 4 (11 x 4)	10.26 (261)	42.99 (1092)	7.01 (178)	□12.49 (□317)	721 (327)	47.13 (1197)	12.30 (313)	□12.61 (□320)	9.53 (242)		765 (347)
CVVM20-6205Y-EP	20 x 4 (15 x 4)	10.26 (261)	41.02 (1042)			767 (348)						46.32 (1177)
CVVM20-6205DBY-EP	20 x 4 (15 x 4)	13.39 (340)	45.43 (1154)	9.06 (230)	□15.12 (□384)	801 (364)	50.73 (1289)	15.91 (404)	□15.28 (□388)	12.13 (308)		887 (403)
CVVM25-6205Y-EP	25 x 4 (18.5 x 4)	13.39 (340)	44.80 (1138)			1040 (472)						51.65 (1312)
CVVM30-6205Y-EP	30 x 4 (22 x 4)	16.33 (415)	51.14 (1299)	16.81 (427)	□18.66 (□474)	1153 (523)	56.54 (1436)					1250 (567)
CVVM40-6205Y-EP	40 x 4 (30 x 4)					49.69 (1262)						1221 (554)
CVVM50-6205Y-EP	50 x 4 (37 x 4)											
CVVM60-6205Y-EP	60 x 4 (45 x 4)											
CVVM75-6205Y-EP	75 x 4 (55 x 4)											

Note: [1] MP Dimension Symbol ϕ = Round Fan Cover
MP Dimension Symbol \square = Square Fan Cover

Dimensions Integral Vertical V-Flange Mount

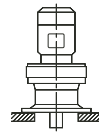

CVVM2-6215DAY-EP ▶ CVVM75-6215Y-EP

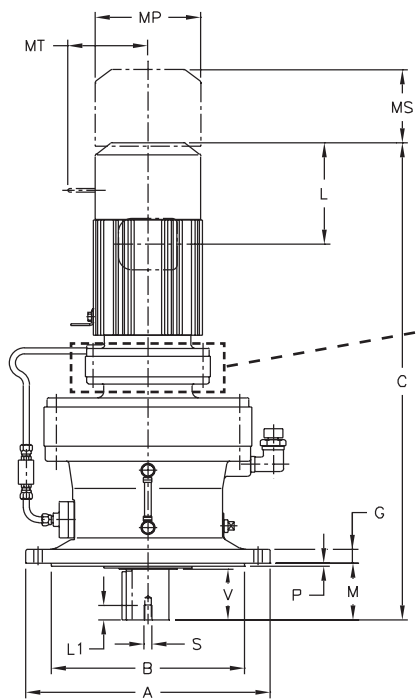
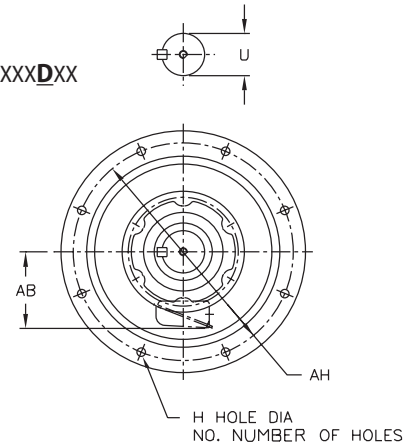

Table 1: Shaft Tolerances

All dimensions are in inches (mm)

Low Speed Shaft Nominal Diameter	Tolerance
0.500 through 0.625 (12.700 through 15.875)	+0.0000 / -0.0004 (+0.000 / -0.011)
0.750 through 1.125 (19.050 through 28.757)	+0.0000 / -0.0005 (+0.000 / -0.013)
1.250 through 1.875 (31.750 through 47.625)	+0.0000 / -0.0006 (+0.000 / -0.016)
2.000 through 3.125 (50.800 through 79.375)	+0.0000 / -0.0007 (+0.000 / -0.019)
3.250 through 4.625 (82.550 through 117.475)	+0.0000 / -0.0009 (+0.000 / -0.022)
4.750 through 7.000 (120.650 through 177.800)	+0.0000 / -0.0010 (+0.000 / -0.025)

Extension for Double reductions only, XXXX-6XXXDXX



Note: CVVM units are oil lubricated standard, must be installed as shown above.

Dimensions are in inches (mm)

Model CVVM	A	B	G	H	NO.	M	O	P	AH
6215Y	19.29 (490)	15.35 (390)	1.38 (35)	0.94 (24)	8	7.99 (203)	-	0.28 (7)	17.32 (440)

All dimensions are in inches (mm)

Model CVVM	Low Speed Shaft				Key
	U*	V	S	L1	
6215Y	4.25 (107.95)	6.50 (165)	3/4-10UNC	1.34 (34)	1 x 1 x 6.5 (25.4 x 25.4 x 165)

Note: [A] Toleranced dimension, please refer to Table 1 above.

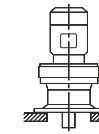

Dimensions Integral Vertical V-Flange Mount

CVVM2-6215DAY-EP ▶ CVVM75-6215Y-EP

XXXX-6XX0/6XX5 Frame sizes have equal dimensions, different ratings.

All dimensions are in inches (mm), lbs (kg)

Model	HP x P (kW x P)	AB	Without Brake				With Brake						
			C	ML	MP ^[1]	Weight lb (kg)	C	ML	MP ^[1]	MS	MT	Weight lb (kg)	
CVVM2-6215DAY-EP	2 x 4 (1.5 x 4)	6.16 (156)	37.72 (958)	3.82 (97)	□6.57 (□167)	777 (353)	40.45 (1028)	6.56 (167)	□6.57 (□167)	5.04 (128)	4.61 (117)	788 (358)	
CVVM3-6215DAY-EP	3 x 4 (2.2 x 4)	6.71 (170)	37.13 (943)	4.53 (115)	□7.24 (□184)	788 (358)	40.20 (1021)	7.60 (193)	□7.24 (□184)	5.43 (138)	5.04 (128)	805 (365)	
CVVM5-6215DAY-EP	5 x 4 (3.7 x 4)	7.34 (186)	38.39 (975)	4.65 (118)	□8.74 (□222)	812 (369)	41.95 (1066)	8.21 (209)	□8.74 (□222)	6.02 (153)	6.30 (160)	836 (380)	
CVVM5-6215DBY-EP	39.57 (1005)		854 (388)			878 (398)							
CVVM8-6215DAY-EP	40.08 (1018)		846 (384)			870 (395)							
CVVM8-6215DBY-EP	41.26 (1048)	888 (403)	44.82 (1139)	912 (414)									
CVVM10-6215DAY-EP	10 x 4 (7.5 x 4)	9.04 (230)	41.57 (1056)	5.43 (138)	□10.24 (□260)	873 (396)	45.71 (1161)	9.57 (243)	□10.24 (□260)	7.44 (189)	7.32 (186)	918 (416)	
CVVM10-6215DBY-EP	42.72 (1085)		916 (416)			960 (436)							
CVVM15-6215Y-EP	39.29 (998)		846 (384)			890 (404)							
CVVM15-6215DAY-EP	15 x 4 (11 x 4)	10.26 (261)	44.02 (1118)	7.01 (178)	∅12.49 (∅317)	886 (402)	48.15 (1223)	12.30 (313)	∅12.61 (∅320)	9.53 (242)	-	930 (422)	
CVVM15-6215DBY-EP	45.16 (1147)		928 (421)			973 (441)							
CVVM20-6215Y-EP	20 x 4 (15 x 4)		41.97 (1066)			931 (422)						47.26 (1201)	1017 (461)
CVVM20-6215DAY-EP	25 x 4 (18.5 x 4)	13.39 (340)	46.46 (1180)	9.06 (230)	∅15.12 (∅384)	966 (439)	51.75 (1315)	15.91 (404)	∅15.28 (∅388)	12.13 (308)	-	1052 (478)	
CVVM20-6215DBY-EP			47.44 (1205)			1012 (459)						52.74 (1340)	1098 (498)
CVVM25-6215Y-EP			45.75 (1162)			1198 (544)						52.60 (1336)	1295 (588)
CVVM25-6215DBY-EP	51.61 (1311)	1289 (585)	58.46 (1485)	1386 (629)									
CVVM30-6215Y-EP	30 x 4 (22 x 4)	16.33 (415)	45.75 (1162)	16.81 (427)	∅18.66 (∅474)	1198 (544)	52.60 (1336)	-	-	-	-	1295 (588)	
CVVM30-6215DBY-EP	51.61 (1311)		1289 (585)			58.46 (1485)						1386 (629)	
CVVM40-6215Y-EP	40 x 4 (30 x 4)		50.63 (1286)			1311 (595)						57.48 (1460)	1408 (639)
CVVM50-6215Y-EP	50 x 4 (37 x 4)	16.33 (415)	52.09 (1323)	16.81 (427)	∅18.66 (∅474)	1379 (626)	-	-	-	-	-	-	
CVVM60-6215Y-EP	60 x 4 (45 x 4)					1507 (684)							
CVVM75-6215Y-EP	75 x 4 (55 x 4)					1588 (720)							

Note: [1] MP Dimension Symbol ∅ = Round Fan Cover
MP Dimension Symbol □ = Square Fan Cover

Dimensions Integral Vertical V-Flange Mount

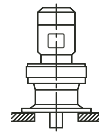

CVVM2-6225DAY-EP ▶ CVVM50-6235DBY-EP

Table 1: Shaft Tolerances

All dimensions are in inches (mm)

Low Speed Shaft Nominal Diameter	Tolerance
0.500 through 0.625 (12.700 through 15.875)	+0.0000 / -0.0004 (+0.000 / -0.011)
0.750 through 1.125 (19.050 through 28.757)	+0.0000 / -0.0005 (+0.000 / -0.013)
1.250 through 1.875 (31.750 through 47.625)	+0.0000 / -0.0006 (+0.000 / -0.016)
2.000 through 3.125 (50.800 through 79.375)	+0.0000 / -0.0007 (+0.000 / -0.019)
3.250 through 4.625 (82.550 through 117.475)	+0.0000 / -0.0009 (+0.000 / -0.022)
4.750 through 7.000 (120.650 through 177.800)	+0.0000 / -0.0010 (+0.000 / -0.025)

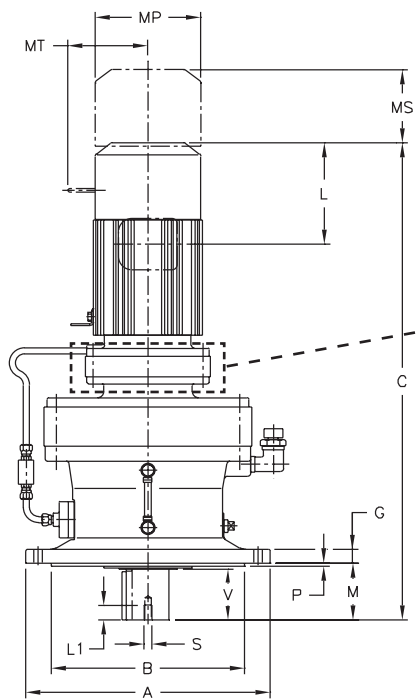

Extension for Double reductions only, XXXX-6XXXDXX

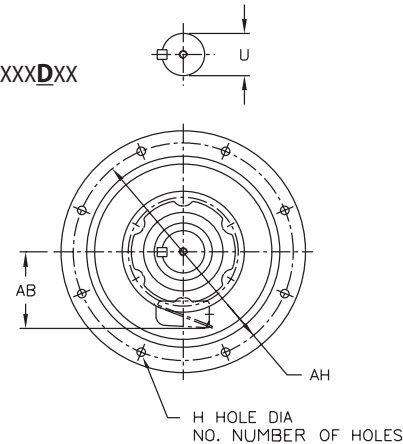

Note: CVVM units are oil lubricated standard, must be installed as shown above.

Dimensions are in inches (mm)

Model CVVM	A	B	G	H	NO.	M	O	P	AH
6225Y	19.29 (490)	15.35 (390)	1.38 (35)	0.94 (24)	8	7.99 (203)	-	0.28 (7)	17.32 (440)
6235Y	22.44 (570)	17.72 (450)	1.57 (40)	1.06 (27)	8	9.84 (250)	-	0.39 (10)	20.08 (510)

All dimensions are in inches (mm)

Model CVVM	Low Speed Shaft				
	U*	V	S	L1	Key
6225Y	4.25 (107.95)	6.50 (165)	3/4-10UNC	1.34 (34)	1 x 1 x 6.5 (25.4 x 25.4 x 165)
6235Y	5.00 (127)	7.87 (200)	1-8UNC	1.61 (41)	1-1/4 x 7/8 x 7.87 (31.75 x 22.225 x 200)

Note: [A] Toleranced dimension, please refer to Table 1 above.

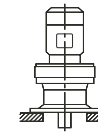

Dimensions Integral Vertical V-Flange Mount

CVVM2-6225DAY-EP ▶ CVVM50-6235DBY-EP

XXXX-6XX0/6XX5 Frame sizes have equal dimensions, different ratings.

All dimensions are in inches (mm), lbs (kg)

Model	HP x P (kW x P)	AB	Without Brake				With Brake					
			C	ML	MP ^[1]	Weight lb (kg)	C	ML	MP ^[1]	MS	MT	Weight lb (kg)
CVVM2-6225DAY-EP	2 x 4 (1.5 x 4)	6.16 (156)	39.37 (1000)	3.82 (97)	□6.57 (□167)	942 (428)	42.11 (1070)	6.56 (167)	□6.57 (□167)	5.04 (128)	4.61 (117)	954 (433)
CVVM3-6225DAY-EP	3 x 4 (2.2 x 4)	6.71 (170)	38.78 (985)	4.53 (115)	□7.24 (□184)	953 (433)	41.85 (1063)	7.60 (193)	□7.24 (□184)	5.43 (138)	5.04 (128)	970 (440)
CVVM5-6225DAY-EP	5 x 4 (3.7 x 4)	7.34 (186)	40.04 (1017)	4.65 (118)	□8.74 (□222)	978 (444)	43.60 (1108)	8.21 (209)	□8.74 (□222)	6.02 (153)	6.30 (160)	1001 (455)
CVVM5-6225DBY-EP	42.13 (1070)		1078 (489)			45.69 (1161)						1102 (500)
CVVM8-6225DAY-EP	41.73 (1060)		1012 (459)			45.30 (1151)						1036 (470)
CVVM8-6225DBY-EP	43.82 (1113)	1112 (505)	47.38 (1204)	1136 (516)								
CVVM10-6225DAY-EP	10 x 4 (7.5 x 4)	9.04 (230)	43.23 (1098)	5.43 (138)	□10.24 (□260)	1039 (471)	47.36 (1203)	9.57 (243)	□10.24 (□260)	7.44 (189)	7.32 (186)	1083 (491)
CVVM10-6225DBY-EP	44.65 (1134)		1141 (518)			48.78 (1239)						1185 (538)
CVVM15-6225DAY-EP	45.67 (1160)		1051 (477)			49.80 (1265)						1095 (497)
CVVM15-6225DBY-EP	47.09 (1196)	1154 (524)	51.22 (1301)	1198 (544)								
CVVM20-6225DAY-EP	20 x 4 (15 x 4)	10.26 (261)	48.11 (1222)	7.01 (178)	ø12.49 (ø317)	1132 (514)	53.41 (1357)	12.30 (313)	ø12.61 (ø320)	9.53 (242)		1218 (553)
CVVM20-6225DBY-EP	49.80 (1265)		1234 (560)			55.10 (1400)						1320 (599)
CVVM25-6225Y-EP	25 x 4 (18.5 x 4)	13.39 (340)	47.32 (1202)	9.06 (230)	ø15.12 (ø384)	1397 (634)	54.17 (1376)	15.91 (404)	ø15.28 (ø388)	12.13 (308)		1494 (678)
CVVM25-6225DBY-EP	53.98 (1371)		1513 (687)			60.83 (1545)						1610 (731)
CVVM30-6225Y-EP	47.32 (1202)		1397 (634)			54.17 (1376)						1494 (678)
CVVM30-6225DBY-EP	53.98 (1371)		1513 (687)			60.83 (1545)						1610 (731)
CVVM40-6225Y-EP	52.20 (1326)		1510 (685)			59.06 (1500)						1607 (729)
CVVM40-6225DBY-EP	58.86 (1495)	1627 (738)	65.71 (1669)	1724 (782)								
CVVM50-6225Y-EP	50 x 4 (37 x 4)	16.33 (415)	52.20 (1326)	16.81 (427)	ø18.66 (ø474)	1578 (716)						1578 (716)
CVVM60-6225Y-EP	60 x 4 (45 x 4)		1703 (773)			1783 (809)						1703 (773)
CVVM75-6225Y-EP	75 x 4 (55 x 4)		1783 (809)									1783 (809)
CVVM3-6235DAY-EP	3 x 4 (2.2 x 4)	6.71 (170)	42.17 (1071)	4.53 (115)	□7.24 (□184)	1171 (531)	45.24 (1149)	7.60 (193)	□7.24 (□184)	5.43 (138)	5.04 (128)	1188 (539)
CVVM5-6235DAY-EP	5 x 4 (3.7 x 4)	7.34 (186)	43.62 (1108)	4.65 (118)	□8.74 (□222)	1196 (543)	47.19 (1199)	8.21 (209)	□8.74 (□222)	6.02 (153)	6.30 (160)	1220 (553)
CVVM8-6235DAY-EP	45.31 (1151)		1230 (558)			48.88 (1242)						1254 (569)
CVVM10-6235DAY-EP	10 x 4 (7.5 x 4)	9.04 (230)	46.77 (1188)	5.43 (138)	□10.24 (□260)	1258 (571)	50.91 (1293)	9.57 (243)	□10.24 (□260)	7.44 (189)	7.32 (186)	1302 (591)
CVVM15-6235DAY-EP	49.21 (1250)		1270 (576)			53.35 (1355)						1314 (596)
CVVM15-6235DBY-EP	49.76 (1264)		1348 (612)			53.90 (1369)						1392 (632)
CVVM20-6235DAY-EP	20 x 4 (15 x 4)	10.26 (261)	51.50 (1308)	7.01 (178)	ø12.49 (ø317)	1353 (614)	56.79 (1443)	12.30 (313)	ø12.61 (ø320)	9.53 (242)		1439 (653)
CVVM20-6235DBY-EP	52.36 (1330)		1428 (648)			57.66 (1465)						1514 (687)
CVVM25-6235DAY-EP	25 x 4 (18.5 x 4)	13.39 (340)	55.67 (1414)	9.06 (230)	ø15.12 (ø384)	1631 (740)	62.52 (1588)	15.91 (404)	ø15.28 (ø388)	12.13 (308)		1728 (784)
CVVM25-6235DBY-EP	56.54 (1436)		1705 (774)			63.39 (1610)						1802 (818)
CVVM30-6235DAY-EP	55.67 (1414)		1631 (740)			62.52 (1588)						1728 (784)
CVVM30-6235DBY-EP	56.54 (1436)		1705 (774)			63.39 (1610)						1802 (818)
CVVM40-6235DBY-EP	61.42 (1560)		1818 (825)			68.27 (1734)						1915 (869)
CVVM50-6235DBY-EP	50 x 4 (37 x 4)				1886 (856)							

Note: [1] MP Dimension Symbol ø = Round Fan Cover
MP Dimension Symbol □ = Square Fan Cover

Dimensions Integral Vertical V-Flange Mount

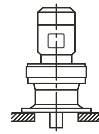

CVVM3-6245DAY-EP ▶ CVVM60-6255DBY-EP

Table 1: Shaft Tolerances

All dimensions are in inches (mm)

Low Speed Shaft Nominal Diameter	Tolerance
0.500 through 0.625 (12.700 through 15.875)	+0.0000 / -0.0004 (+0.000 / -0.011)
0.750 through 1.125 (19.050 through 28.757)	+0.0000 / -0.0005 (+0.000 / -0.013)
1.250 through 1.875 (31.750 through 47.625)	+0.0000 / -0.0006 (+0.000 / -0.016)
2.000 through 3.125 (50.800 through 79.375)	+0.0000 / -0.0007 (+0.000 / -0.019)
3.250 through 4.625 (82.550 through 117.475)	+0.0000 / -0.0009 (+0.000 / -0.022)
4.750 through 7.000 (120.650 through 177.800)	+0.0000 / -0.0010 (+0.000 / -0.025)

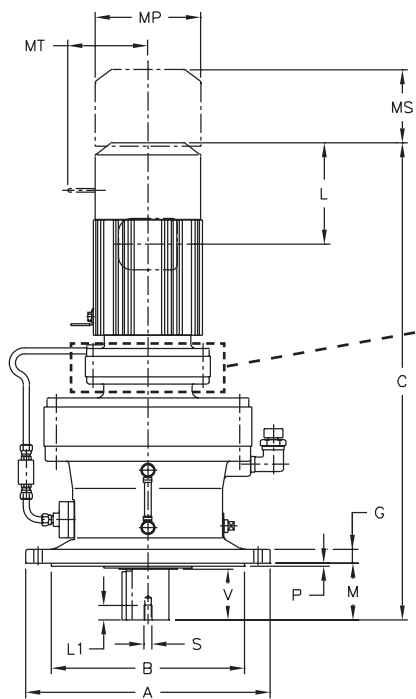

Extension for Double reductions only, XXXX-6XXXDXX

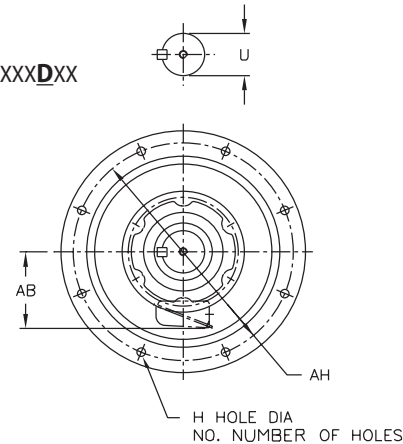

Note: CVVM units are oil lubricated standard, must be installed as shown above.

Dimensions are in inches (mm)

Model CVVM	A	B	G	H	NO.	M	O	P	AH
6245Y	25.00 (635)	19.09 (485)	1.57 (40)	1.30 (33)	8	9.84 (250)	-	0.39 (10)	22.05 (560)
6255Y	26.97 (685)	21.06 (535)	1.77 (45)	1.30 (33)	8	11.61 (295)	-	0.39 (10)	24.02 (610)

All dimensions are in inches (mm)

Model CVVM	Low Speed Shaft				
	U*	V	S	L1	Key
6245Y	5.50 (139.7)	7.87 (200)	1-8UNC	1.61 (41)	1-1/4 x 7/8 x 7.87 (31.75 x 22.225 x 200)
6255Y	6.25 (158.75)	9.45 (240)	1-1/4-7UNC	2.05 (52)	1-1/2 x 1 x 9.45 (38.1 x 25.4 x 240)

Note: [A] Toleranced dimension, please refer to Table 1 above.

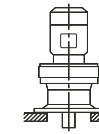

Dimensions Integral Vertical V-Flange Mount

CVVM3-6245DAY-EP ▶ CVVM60-6255DBY-EP

XXXX-6XX0/6XX5 Frame sizes have equal dimensions, different ratings.

All dimensions are in inches (mm), lbs (kg)

Model	HP x P (kW x P)	AB	Without Brake				With Brake					
			C	ML	MP ^[1]	Weight lb (kg)	C	ML	MP ^[1]	MS	MT	Weight lb (kg)
CVVM3-6245DAY-EP	3 x 4 (2.2 x 4)	6.71 (170)	43.66 (1109)	4.53 (115)	□7.24 (□184)	1378 (625)	46.73 (1187)	7.60 (193)	□7.24 (□184)	5.43 (138)	5.04 (128)	1395 (633)
CVVM5-6245DAY-EP	5 x 4 (3.7 x 4)	7.34 (186)	45.12 (1146)	4.65 (118)	□8.74 (□222)	1403 (637)	48.68 (1237)	8.21 (209)	□8.74 (□222)	6.02 (153)	6.30 (160)	1427 (647)
CVVM8-6245DAY-EP	7.5 x 4 (5.5 x 4)		46.81 (1189)			1437 (652)						50.37 (1280)
CVVM10-6245DAY-EP	10 x 4 (7.5 x 4)	9.04 (230)	48.27 (1226)	5.43 (138)	□10.24 (□260)	1465 (665)	52.40 (1331)	9.57 (243)	□10.24 (□260)	7.44 (189)	7.32 (186)	1509 (685)
CVVM15-6245DAY-EP	15 x 4 (11 x 4)		50.71 (1288)			1477 (670)						54.84 (1393)
CVVM15-6245DBY-EP	15 x 4 (11 x 4)		51.22 (1301)			1544 (701)	55.35 (1406)					1589 (721)
CVVM20-6245DAY-EP	20 x 4 (15 x 4)	10.26 (261)	52.99 (1346)	7.01 (178)	ø12.49 (ø317)	1561 (708)	58.29 (1481)	12.30 (313)	ø12.61 (ø320)	9.53 (242)		1647 (747)
CVVM20-6245DBY-EP	20 x 4 (15 x 4)		53.82 (1367)			1624 (737)						59.11 (1502)
CVVM25-6245DAY-EP	25 x 4 (18.5 x 4)	13.39 (340)	57.17 (1452)	9.06 (230)	ø15.12 (ø384)	1838 (834)	64.02 (1626)	15.91 (404)	ø15.28 (ø388)	12.13 (308)		1935 (878)
CVVM25-6245DBY-EP	25 x 4 (18.5 x 4)		57.99 (1473)			1901 (863)						64.84 (1647)
CVVM30-6245DAY-EP	30 x 4 (22 x 4)		57.17 (1452)			1838 (834)	64.02 (1626)					1935 (878)
CVVM30-6245DBY-EP	30 x 4 (22 x 4)		57.99 (1473)			1901 (863)	64.84 (1647)					1998 (907)
CVVM40-6245DBY-EP	40 x 4 (30 x 4)					2014 (914)	69.72 (1771)					2111 (958)
CVVM50-6245DBY-EP	50 x 4 (37 x 4)		62.87 (1597)			2083 (945)	-	-	-	-		-
CVVM5-6255DAY-EP	5 x 4 (3.7 x 4)	7.34 (186)	50.83 (1291)	4.65 (118)	□8.74 (□222)	2114 (959)	54.39 (1382)	8.21 (209)	□8.74 (□222)	6.02 (153)	6.30 (160)	2138 (970)
CVVM8-6255DAY-EP	7.5 x 4 (5.5 x 4)		52.52 (1334)			2148 (975)						56.08 (1425)
CVVM10-6255DAY-EP	10 x 4 (7.5 x 4)	9.04 (230)	53.35 (1355)	5.43 (138)	□10.24 (□260)	2177 (988)	57.48 (1460)	9.57 (243)	□10.24 (□260)	7.44 (189)	7.32 (186)	2221 (1008)
CVVM15-6255DAY-EP	15 x 4 (11 x 4)		55.79 (1417)			2190 (994)						59.92 (1522)
CVVM15-6255DBY-EP	15 x 4 (11 x 4)		56.65 (1439)			2336 (1060)	60.79 (1544)					2380 (1080)
CVVM20-6255DAY-EP	20 x 4 (15 x 4)	10.26 (261)	58.50 (1486)	7.01 (178)	ø12.49 (ø317)	2270 (1030)	63.80 (1621)	12.30 (313)	ø12.61 (ø320)	9.53 (242)		2356 (1069)
CVVM20-6255DBY-EP	20 x 4 (15 x 4)		59.37 (1508)			2414 (1095)						64.67 (1643)
CVVM25-6255DAY-EP	25 x 4 (18.5 x 4)	13.39 (340)	62.68 (1592)	9.06 (230)	ø15.12 (ø384)	2550 (1157)	69.53 (1766)	15.91 (404)	ø15.28 (ø388)	12.13 (308)		2647 (1201)
CVVM25-6255DBY-EP	25 x 4 (18.5 x 4)		63.54 (1614)			2692 (1222)						70.39 (1788)
CVVM30-6255DAY-EP	30 x 4 (22 x 4)		62.68 (1592)			2550 (1157)	69.53 (1766)					2647 (1201)
CVVM30-6255DBY-EP	30 x 4 (22 x 4)		63.54 (1614)			2692 (1222)	70.39 (1788)					2789 (1266)
CVVM40-6255DAY-EP	40 x 4 (30 x 4)		67.56 (1716)			2663 (1208)	74.41 (1890)					2760 (1252)
CVVM40-6255DBY-EP	40 x 4 (30 x 4)		68.43 (1738)			2805 (1273)	75.28 (1912)					2902 (1317)
CVVM50-6255DBY-EP	50 x 4 (37 x 4)					2874 (1304)	-	-	-	-		-
CVVM60-6255DBY-EP	60 x 4 (45 x 4)	16.33 (415)	69.88 (1775)	16.81 (427)	ø18.66 (ø474)	3002 (1362)	-	-	-	-		-

Note: [1] MP Dimension Symbol ø = Round Fan Cover
MP Dimension Symbol □ = Square Fan Cover

Dimensions Integral Vertical V-Flange Mount

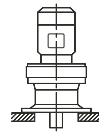

CVVM8-6265DAY-EP ▶ CVVM60-6275DAY-EP

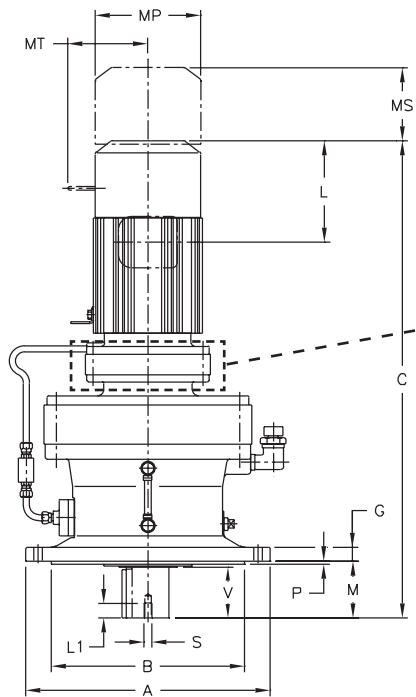
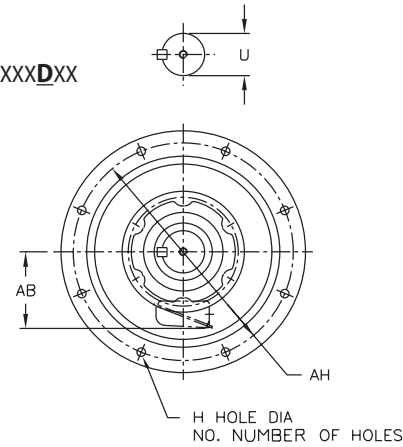

Table 1: Shaft Tolerances

All dimensions are in inches (mm)

Low Speed Shaft Nominal Diameter	Tolerance
0.500 through 0.625 (12.700 through 15.875)	+0.0000 / -0.0004 (+0.000 / -0.011)
0.750 through 1.125 (19.050 through 28.757)	+0.0000 / -0.0005 (+0.000 / -0.013)
1.250 through 1.875 (31.750 through 47.625)	+0.0000 / -0.0006 (+0.000 / -0.016)
2.000 through 3.125 (50.800 through 79.375)	+0.0000 / -0.0007 (+0.000 / -0.019)
3.250 through 4.625 (82.550 through 117.475)	+0.0000 / -0.0009 (+0.000 / -0.022)
4.750 through 7.000 (120.650 through 177.800)	+0.0000 / -0.0010 (+0.000 / -0.025)

Extension for **Double** reductions only, XXXX-6XXXDXX



Note: CVVM units are oil lubricated standard, must be installed as shown above.

Dimensions are in inches (mm)

Model CVVM	A	B	G	H	NO.	M	O	P	AH
6265Y	29.53 (750)	22.44 (570)	1.97 (50)	1.14 (29)	8	14.17 (360)	-	0.39 (10)	25.98 (660)
6275Y	45.67 (1160)	35.43 (900)	2.36 (60)	1.54 (39)	8	13.98 (355)	-	0.39 (10)	40.16 (1020)

All dimensions are in inches (mm)

Model CVVM	Low Speed Shaft				
	U*	V	S	L1	Key
6265Y	6.63 (168.275)	11.81 (300)	1-1/4-7UNC	2.05 (52)	1-3/4 x 1-1/4 x 11.81 (44.45 x 31.75 x 300)
6275Y	7.00 (177.8)	12.60 (320)	1-1/4-7UNC	2.05 (52)	1-3/4 x 1-1/4 x 12.6 (44.45 x 31.75 x 330)

Note: [A] Toleranced dimension, please refer to Table 1 above.

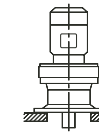

Dimensions Integral Vertical V-Flange Mount

CVVM8-6265DAY-EP ▶ CVVM60-6275DAY-EP

XXXX-6XX0/6XX5 Frame sizes have equal dimensions, different ratings.

All dimensions are in inches (mm), lbs (kg)

Model	HP x P (kW x P)	AB	Without Brake				With Brake					
			C	ML	MP ^[1]	Weight lb (kg)	C	ML	MP ^[1]	MS	MT	Weight lb (kg)
CVVM8-6265DAY-EP	7.5 x 4 (5.5 x 4)	7.34 (186)	58.31 (1481)	4.65 (118)	□8.74 (□222)	2892 (1312)	61.87 (1572)	8.21 (209)	□8.74 (□222)	6.02 (153)	6.30 (160)	2916 (1323)
CVVM10-6265DAY-EP	10 x 4 (7.5 x 4)	9.04 (230)	58.54 (1487)	5.43 (138)	□10.24 (□260)	2923 (1326)	62.68 (1592)	9.57 (243)	□10.24 (□260)	7.44 (189)	7.32 (186)	2967 (1346)
CVVM15-6265DAY-EP	15 x 4 (11 x 4)		60.98 (1549)			2935 (1332)						2980 (1352)
CVVM20-6265DAY-EP	20 x 4 (15 x 4)	10.26 (261)	63.70 (1618)	7.01 (178)	∅12.49 (∅317)	3014 (1367)	69.00 (1753)	12.30 (313)	∅12.61 (∅320)	9.53 (242)	-	3100 (1406)
CVVM25-6265DAY-EP	25 x 4 (18.5 x 4)	13.39 (340)	67.87 (1724)	9.06 (230)	∅15.12 (∅384)	3292 (1494)	74.72 (1898)	15.91 (404)	∅15.28 (∅388)	12.13 (308)	-	3389 (1538)
CVVM30-6265DAY-EP	30 x 4 (22 x 4)		72.76 (1848)			3405 (1545)						3502 (1589)
CVVM40-6265DAY-EP	40 x 4 (30 x 4)		3473 (1576)			-						-
CVVM50-6265DAY-EP	50 x 4 (37 x 4)		-			-						-
CVVM60-6265DAY-EP	60 x 4 (45 x 4)	16.33 (415)	74.21 (1885)	16.81 (427)	∅18.66 (∅474)	3602 (1634)	-	-	-	-	-	-
CVVM10-6275DAY-EP	10 x 4 (7.5 x 4)	9.04 (230)	68.82 (1748)	5.43 (138)	□10.24 (□260)	5998 (2721)	72.95 (1853)	9.57 (243)	□10.24 (□260)	7.44 (189)	7.32 (186)	6042 (2741)
CVVM15-6275DAY-EP	15 x 4 (11 x 4)		71.26 (1810)			6011 (2727)						6055 (2747)
CVVM20-6275DAY-EP	20 x 4 (15 x 4)	10.26 (261)	73.98 (1879)	7.01 (178)	∅12.49 (∅317)	6089 (2762)	79.27 (2014)	12.30 (313)	∅12.61 (∅320)	9.53 (242)	-	6175 (2801)
CVVM25-6275DAY-EP	25 x 4 (18.5 x 4)	13.39 (340)	78.15 (1985)	9.06 (230)	∅15.12 (∅384)	6367 (2889)	85.00 (2159)	15.91 (404)	∅15.28 (∅388)	12.13 (308)	-	6464 (2933)
CVVM30-6275DAY-EP	30 x 4 (22 x 4)		83.03 (2109)			6481 (2940)						6578 (2984)
CVVM40-6275DAY-EP	40 x 4 (30 x 4)		6549 (2971)			-						-
CVVM50-6275DAY-EP	50 x 4 (37 x 4)		-			-						-
CVVM60-6275DAY-EP	60 x 4 (45 x 4)	16.33 (415)	84.49 (2146)	16.81 (427)	∅18.66 (∅474)	6677 (3029)	-	-	-	-	-	-

Note: [1] MP Dimension Symbol ∅ = Round Fan Cover
MP Dimension Symbol □ = Square Fan Cover

Dimensions Integral Universal F-Flange Mount

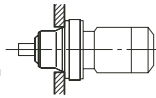

CNFM01-6065Y ▶ CNFM1-6085Y-EP

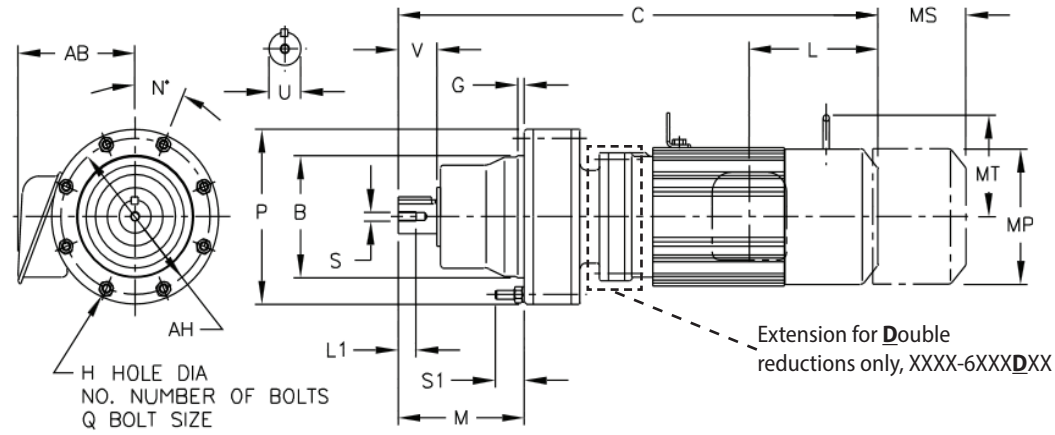

Table 1: Shaft Tolerances All dimensions are in inches (mm)

Low Speed Shaft Nominal Diameter	Tolerance
0.500 through 0.625 (12.700 through 15.875)	+0.0000 / -0.0004 (+0.000 / -0.011)
0.750 through 1.125 (19.050 through 28.757)	+0.0000 / -0.0005 (+0.000 / -0.013)
1.250 through 1.875 (31.750 through 47.625)	+0.0000 / -0.0006 (+0.000 / -0.016)
2.000 through 3.125 (50.800 through 79.375)	+0.0000 / -0.0007 (+0.000 / -0.019)
3.250 through 4.625 (82.550 through 117.475)	+0.0000 / -0.0009 (+0.000 / -0.022)
4.750 through 7.000 (120.650 through 177.800)	+0.0000 / -0.0010 (+0.000 / -0.025)

Note: CNFM units are greased for life, and can be mounted in any position.

Dimensions are in inches (mm)

Model CNFM	B	G	H	NO.	M	N	P	Q	S1	AH
6060Y 6065Y	3.15 (80)	0.16 (4)	0.26 (6.6)	6	2.68 (68)	60	4.33 (110)	M6	0.94 (24)	3.86 (98)
6070Y 6075Y	3.15 (80)	0.16 (4)	0.26 (6.6)	6	2.91 (74)	60	4.33 (110)	M6	0.94 (24)	3.86 (98)
6080Y 6085Y	3.74 (95)	0.20 (5)	0.35 (9)	8	3.58 (91)	22.5	5.28 (134)	M8	1.06 (27)	4.65 (118)

All dimensions are in inches (mm)

Model CNFM	Low Speed Shaft				
	U*	V	S	L1	Key
6060Y 6065Y	0.50 (12.7)	0.98 (25)	10-32UNF	0.63 (16)	1/8 X 1/8 X 0.79 (3.175 x 3.175 x 20.07)
6070Y 6075Y	0.75 (19.05)	1.18 (30)	12-28UNF	0.63 (16)	3/16 X 3/16 X 1.18 (4.762 x 4.762 x 30)
6080Y 6085Y	0.88 (22.225)	1.38 (35)	12-28UNF	0.63 (16)	3/16 x 3/16 x 1.18 (4.762 x 4.762 x 30)

Note: [A] Toleranced dimension, please refer to Table 1 above.

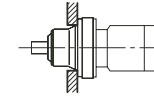

Dimensions Integral Universal F-Flange Mount

CNFM01-6065Y ▶ CNFM1-6085Y-EP

XXXX-6XX0/6XX5 Frame sizes have equal dimensions, different ratings.

All dimensions are in inches (mm), lbs (kg)

Model	HP x P (kW x P)	AB	Without Brake				With Brake												
			C	ML	MP ^[1]	Weight lb (kg)	C	ML	MP ^[1]	MS	MT	Weight lb (kg)							
CNFM01-6065Y	1/8 x 4 (0.1 x 4)	4.63 (118)	8.90 (226)	1.38 (35)	ø4.69 (ø119)	15 (7)	10.28 (261)	2.76 (70)	ø4.88 (ø124)	1.93 (49)		18 (8)							
CNFM01-6065DAY			10.20 (259)			18 (8)	11.57 (294)					21 (10)							
CNFM01-6065Y-AV			10.55 (268)			17 (8)	11.81 (300)					20 (9)							
CNFM01-6065DAY-AV			11.85 (301)	20 (9)		13.11 (333)	23 (11)												
CNFM02-6065Y			1/4 x 4 (0.2 x 4)	4.63 (118)		10.55 (268)	2.32 (59)					ø4.88 (ø124)	17 (8)	11.81 (300)	3.58 (91)		2.40 (61)		20 (9)
CNFM02-6065Y-AV						11.34 (288)							20 (9)	12.60 (320)					23 (11)
CNFM03-6065Y						10.55 (268)							17 (8)	11.81 (300)					20 (9)
CNFM03-6065Y-AV						11.34 (288)							20 (9)	12.60 (320)					23 (11)
CNFM01-6075Y						1/8 x 4 (0.1 x 4)							4.63 (118)	9.13 (232)					1.38 (35)
CNFM01-6075DAY	10.43 (265)	18 (8)	11.81 (300)	21 (10)															
CNFM01-6075Y-AV	10.79 (274)	17 (8)	12.05 (306)	20 (9)															
CNFM01-6075DAY-AV	12.09 (307)	20 (9)	13.35 (339)	23 (11)															
CNFM02-6075Y	1/4 x 4 (0.2 x 4)	4.63 (118)	10.79 (274)	2.32 (59)	ø4.88 (ø124)		17 (8)	12.05 (306)	3.58 (91)		2.40 (61)			20 (9)					
CNFM02-6075Y-AV			11.57 (294)				20 (9)	12.83 (326)						23 (11)					
CNFM02-6075DAY			12.09 (307)				23 (11)	13.35 (339)						26 (12)					
CNFM02-6075DAY-AV			12.87 (327)				17 (8)	14.13 (359)						20 (9)					
CNFM03-6075Y			10.79 (274)				17 (8)	12.05 (306)						20 (9)					
CNFM03-6075Y-AV			11.57 (294)				20 (9)	12.83 (326)						23 (11)					
CNFM05-6075Y	1/2 x 4 (0.4 x 4)	5.67 (144)	14.21 (361)	3.82 (97)	ø5.94 (ø151)	35 (16)	15.91 (404)	5.51 (140)	ø5.94 (ø151)	3.66 (93)	3.94 (100)	41 (19)							
CNFM05-6085Y-AV	3/4 x 4 (0.55 x 4)	14.21 (361)	33 (15)			38 (18)													
CNFM08-6085Y	1 x 4 (0.75 x 4)	5.98 (152)	15.85 (403)			ø6.22 (ø158)	46 (21)					18.35 (466)	6.32 (161)	ø6.22 (ø158)	4.80 (122)	4.25 (108)	55 (25)		

Note: [1] MP Dimension Symbol ø = Round Fan Cover
MP Dimension Symbol □ = Square Fan Cover

Dimensions Integral Universal F-Flange Mount

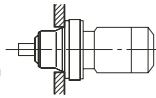

CNFM01-6095Y ▶ CNFM2-6095Y-EP

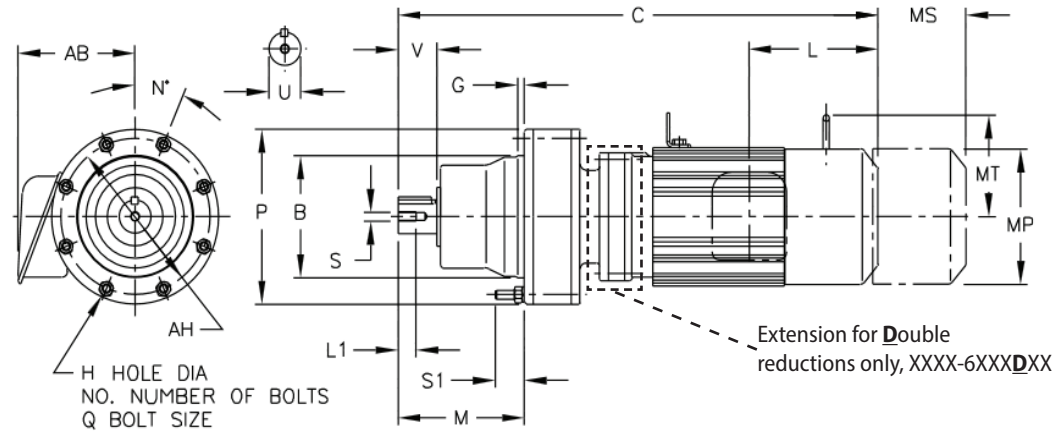

Table 1: Shaft Tolerances All dimensions are in inches (mm)

Low Speed Shaft Nominal Diameter	Tolerance
0.500 through 0.625 (12.700 through 15.875)	+0.0000 / -0.0004 (+0.000 / -0.011)
0.750 through 1.125 (19.050 through 28.757)	+0.0000 / -0.0005 (+0.000 / -0.013)
1.250 through 1.875 (31.750 through 47.625)	+0.0000 / -0.0006 (+0.000 / -0.016)
2.000 through 3.125 (50.800 through 79.375)	+0.0000 / -0.0007 (+0.000 / -0.019)
3.250 through 4.625 (82.550 through 117.475)	+0.0000 / -0.0009 (+0.000 / -0.022)
4.750 through 7.000 (120.650 through 177.800)	+0.0000 / -0.0010 (+0.000 / -0.025)

Note: CNFM units are greased for life, and can be mounted in any position.

Dimensions are in inches (mm)

Model CNFM	B	G	H	NO.	M	N	P	Q	S1	AH
6090Y 6095Y	4.13 (105)	0.24 (6)	0.35 (9)	8	4.49 (114)	22.5	5.91 (150)	M8	1.14 (29)	5.28 (134)

All dimensions are in inches (mm)

Model CNFM	Low Speed Shaft				
	U*	V	S	L1	Key
6090Y 6095Y	1.13 (28.575)	1.38 (35)	5/16-18UNC	0.79 (20)	1/4 x 1/4 x 1.18 (6.35 x 6.35 x 30)

Note: [A] Toleranced dimension, please refer to Table 1 above.

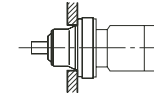

Dimensions Integral Universal F-Flange Mount

CNFM01-6095Y ▶ CNFM2-6095Y-EP

XXXX-6XX0/6XX5 Frame sizes have equal dimensions, different ratings.

All dimensions are in inches (mm), lbs (kg)

Model	HP x P (kW x P)	AB	Without Brake				With Brake																		
			C	ML	MP ^[1]	Weight lb (kg)	C	ML	MP ^[1]	MS	MT	Weight lb (kg)													
CNFM01-6095Y	1/8 x 4 (0.1 x 4)	4.63 (118)	10.87 (276)	1.38 (35)	ø4.69 (ø119)	25 (12)	12.24 (311)	2.76 (70)	ø4.88 (ø124)	2.40 (61)	-	28 (13)													
CNFM01-6095Y-AV			12.52 (318)	2.32 (59)	ø4.88 (ø124)	27 (13)	13.78 (350)	3.58 (91)				30 (14)													
CNFM01-6095DAY			12.76 (324)	1.38 (35)	ø4.69 (ø119)	30 (14)	14.13 (359)	2.76 (70)				33 (15)													
CNFM01-6095DAY-AV	1/4 x 4 (0.2 x 4)		14.41 (366)	2.32 (59)	ø4.88 (ø124)	32 (15)	15.67 (398)	3.58 (91)	2.40 (61)	-	-	35 (16)													
CNFM02-6095Y			12.52 (318)			27 (13)	13.78 (350)					30 (14)													
CNFM02-6095Y-AV			13.31 (338)			30 (14)	14.57 (370)					33 (15)													
CNFM02-6095DAY	14.41 (366)		32 (15)			15.67 (398)	35 (16)																		
CNFM02-6095DAY-AV	15.20 (386)		35 (16)			16.46 (418)	38 (18)																		
CNFM03-6095Y	1/3 x 4 (0.25 x 4)		12.52 (318)			3.82 (97)	ø5.94 (ø151)					27 (13)	13.78 (350)	5.51 (140)	ø5.94 (ø151)	3.66 (93)	3.94 (100)	30 (14)							
CNFM03-6095Y-AV			13.31 (338)									30 (14)	14.57 (370)					33 (15)							
CNFM03-6095DAY			14.41 (366)									32 (15)	15.67 (398)					35 (16)							
CNFM03-6095DAY-AV	15.20 (386)		35 (16)									16.46 (418)	38 (18)												
CNFM05-6095Y	1/2 x 4 (0.4 x 4)	13.31 (338)	5.67 (144)									ø6.30 (ø160)	30 (14)					14.57 (370)	6.61 (168)	ø6.30 (ø160)	4.53 (115)	4.29 (109)	33 (15)		
CNFM05-6095DAY		15.20 (386)											35 (16)					16.46 (418)					38 (18)		
CNFM05-6095Y-AV		5.67 (144)											14.92 (379)					3.82 (97)					ø5.94 (ø151)	37 (17)	16.61 (422)
CNFM08-6095Y	3/4 x 4 (0.55 x 4)	5.86 (149)		16.22 (412)	3.94 (100)			ø6.30 (ø160)	46 (21)	18.66 (474)	6.38 (162)		ø6.30 (ø160)					4.53 (115)					4.29 (109)	41 (19)	
CNFM08-6095Y-AV	5.98 (152)	16.65 (423)		3.82 (97)	ø6.22 (ø158)			51 (23)	19.15 (487)	6.32 (161)	ø6.22 (ø158)		4.80 (122)					4.25 (108)					60 (28)		
CNFM1-6095Y-EP	1 x 4 (0.75 x 4)	6.16 (156)						17.72 (450)	ø6.57 (ø167)	58 (27)	20.45 (520)		6.56 (167)					ø6.57 (ø167)					5.04 (128)	4.61 (117)	70 (32)
CNFM1H-6095Y-EP	1.5 x 4 (1.1 x 4)	6.16 (156)						17.72 (450)	ø6.57 (ø167)	61 (28)	20.45 (520)		6.56 (167)					ø6.57 (ø167)					5.04 (128)	4.61 (117)	72 (33)
CNFM2-6095Y-EP	2 x 4 (1.5 x 4)			61 (28)	72 (33)																				

Note: [1] MP Dimension Symbol ø = Round Fan Cover
MP Dimension Symbol □ = Square Fan Cover

Dimensions

Dimensions

Dimensions Integral Universal F-Flange Mount

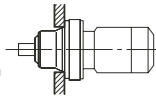

CNFM01-6105DAY ▶ CNFM5-6115Y-EP

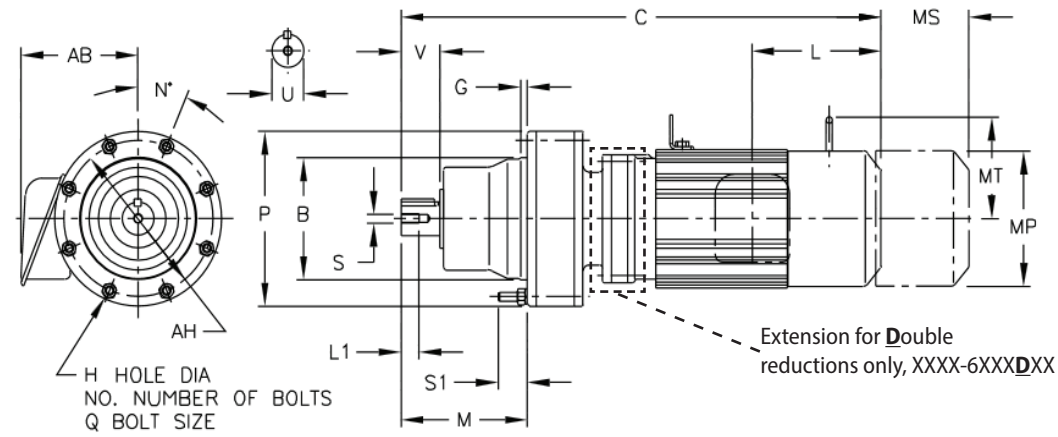

Table 1: Shaft Tolerances All dimensions are in inches (mm)

Low Speed Shaft Nominal Diameter	Tolerance
0.500 through 0.625 (12.700 through 15.875)	+0.0000 / -0.0004 (+0.000 / -0.011)
0.750 through 1.125 (19.050 through 28.757)	+0.0000 / -0.0005 (+0.000 / -0.013)
1.250 through 1.875 (31.750 through 47.625)	+0.0000 / -0.0006 (+0.000 / -0.016)
2.000 through 3.125 (50.800 through 79.375)	+0.0000 / -0.0007 (+0.000 / -0.019)
3.250 through 4.625 (82.550 through 117.475)	+0.0000 / -0.0009 (+0.000 / -0.022)
4.750 through 7.000 (120.650 through 177.800)	+0.0000 / -0.0010 (+0.000 / -0.025)

Note: CNFM units are greased for life, and can be mounted in any position.

Dimensions are in inches (mm)

Model CNFM	B	G	H	NO.	M	N	P	Q	S1	AH
6100Y 6105Y	4.13 (105)	0.24 (6)	0.35 (9)	8	4.49 (114)	22.5	5.91 (150)	M8	1.10 (28)	5.28 (134)
6110Y 6115Y	4.53 (115)	0.24 (6)	0.35 (9)	8	4.65 (118)	22.5	6.38 (162)	M8	1.10 (28)	5.75 (146)

All dimensions are in inches (mm)

Model CNFM	Low Speed Shaft				
	U*	V	S	L1	Key
6100Y 6105Y	1.13 (28.575)	1.38 (35)	5/16-18UNC	0.79 (20)	1/4 x 1/4 x 1.18 (6.35 x 6.35 x 30)
6110Y 6115Y	1.25 (31.75)	1.77 (45)	5/16-18UNC	0.79 (20)	1/4 x 1/4 x 1.46 (6.35 x 6.35 x 37)

Note: [A] Toleranced dimension, please refer to Table 1 above.

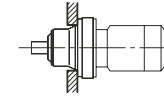

Dimensions Integral Universal F-Flange Mount

CNFM01-6105DAY ▶ CNFM5-6115Y-EP

XXXX-6XX0/6XX5 Frame sizes have equal dimensions, different ratings.

All dimensions are in inches (mm), lbs (kg)

Model	HP x P (kW x P)	AB	Without Brake				With Brake							
			C	ML	MP ^[1]	Weight lb (kg)	C	ML	MP ^[1]	MS	MT	Weight lb (kg)		
CNFM01-6105DAY	1/8 x 4 (0.1 x 4)	4.63 (118)	13.31 (338)	1.38 (35)	ø4.69 (ø119)	34 (16)	14.69 (373)	2.76 (70)	ø4.88 (ø124)	2.40 (61)	-	38 (17)		
CNFM01-6105DAY-AV			14.96 (380)			37 (17)	16.22 (412)						40 (18)	
CNFM02-6105Y	1/4 x 4 (0.2 x 4)		13.07 (332)			30 (14)	14.33 (364)						33 (15)	
CNFM02-6105Y-AV			13.86 (352)			33 (15)	15.12 (384)						36 (16)	
CNFM02-6105DAY			14.96 (380)			37 (17)	16.22 (412)						40 (18)	
CNFM02-6105DAY-AV			15.75 (400)			40 (18)	17.01 (432)						43 (20)	
CNFM03-6105Y			1/3 x 4 (0.25 x 4)	13.07 (332)	2.32 (59)		30 (14)	14.33 (364)					3.58 (91)	33 (15)
CNFM03-6105Y-AV				13.86 (352)			33 (15)	15.12 (384)						36 (16)
CNFM03-6105DAY	14.96 (380)					37 (17)	16.22 (412)						40 (18)	
CNFM03-6105DAY-AV	15.75 (400)					40 (18)	17.01 (432)						43 (20)	
CNFM05-6105Y	1/2 x 4 (0.4 x 4)			13.86 (352)			33 (15)	15.12 (384)						36 (16)
CNFM05-6105DAY				15.75 (400)			40 (18)	17.01 (432)						43 (20)
CNFM05-6105Y-AV		5.67 (144)	15.47 (393)	3.82 (97)	ø5.94 (ø151)	37 (17)	17.17 (436)	5.51 (140)	ø5.94 (ø151)	3.66 (93)	3.94 (100)	46 (21)		
CNFM08-6105Y	3/4 x 4 (0.55 x 4)	5.86 (149)	16.77 (426)	3.94 (100)	ø6.30 (ø160)	48 (22)	19.21 (488)	6.38 (162)	ø6.30 (ø160)	4.53 (115)	4.29 (109)	59 (27)		
CNFM1-6105Y-EP	1 x 4 (0.75 x 4)	5.98 (152)	17.20 (437)	3.82 (97)	ø6.22 (ø158)	53 (24)	19.70 (501)	6.32 (161)	ø6.22 (ø158)	4.80 (122)	4.25 (108)	63 (29)		
CNFM1H-6105Y-EP	1.5 x 4 (1.1 x 4)	6.16 (156)	18.27 (464)		ø6.57 (ø167)	60 (28)	21.00 (534)	6.56 (167)	ø6.57 (ø167)	5.04 (128)	4.61 (117)	72 (33)		
CNFM2-6105Y-EP	2 x 4 (1.5 x 4)				ø6.57 (ø167)	63 (29)						75 (34)		
CNFM3-6105Y-EP	3 x 4 (2.2 x 4)	6.71 (170)	19.09 (485)	4.53 (115)	ø7.24 (ø184)	79 (36)	22.17 (563)	7.60 (193)	ø7.24 (ø184)	5.43 (138)	5.04 (128)	96 (44)		
CNFM05-6115Y	1/2 x 4 (0.4 x 4)	4.63 (118)	14.25 (362)	2.32 (59)	ø4.88 (ø124)	38 (18)	15.51 (394)	3.58 (91)	ø4.88 (ø124)	2.40 (61)	-	41 (19)		
CNFM05-6115Y-AV		5.67 (144)	15.87 (403)	3.82 (97)	ø5.94 (ø151)	45 (21)	17.56 (446)	5.51 (140)	ø5.94 (ø151)	3.66 (93)	3.94 (100)	51 (23)		
CNFM08-6115Y	3/4 x 4 (0.55 x 4)	5.86 (149)	17.17 (436)	3.94 (100)	ø6.30 (ø160)	42 (19)						62 (28)		
CNFM08-6115Y-AV		5.86 (149)	17.17 (436)	3.94 (100)	ø6.30 (ø160)	51 (24)	19.61 (498)	6.38 (162)	ø6.30 (ø160)	4.53 (115)	4.29 (109)	62 (28)		
CNFM1-6115Y-EP	1 x 4 (0.75 x 4)	5.98 (152)	17.60 (447)	3.82 (97)	ø6.22 (ø158)	56 (26)	20.10 (511)	6.32 (161)	ø6.22 (ø158)	4.80 (122)	4.25 (108)	66 (30)		
CNFM1H-6115Y-EP	1.5 x 4 (1.1 x 4)	6.16 (156)	18.66 (474)		ø6.57 (ø167)	63 (29)	21.40 (544)	6.56 (167)	ø6.57 (ø167)	5.04 (128)	4.61 (117)	75 (34)		
CNFM2-6115Y-EP	2 x 4 (1.5 x 4)				ø6.57 (ø167)	66 (30)						78 (36)		
CNFM3-6115Y-EP	3 x 4 (2.2 x 4)	6.71 (170)	18.54 (471)	4.53 (115)	ø7.24 (ø184)	78 (36)	21.61 (549)	7.60 (193)	ø7.24 (ø184)	5.43 (138)	5.04 (128)	95 (43)		
CNFM5-6115Y-EP	5 x 4 (3.7 x 4)	7.34 (186)	19.61 (498)	4.65 (118)	ø8.74 (ø222)	104 (47)	23.17 (589)	8.21 (209)	ø8.74 (ø222)	6.02 (153)	6.30 (160)	128 (58)		

Note: [1] MP Dimension Symbol ø = Round Fan Cover
MP Dimension Symbol □ = Square Fan Cover

Dimensions Integral Universal F-Flange Mount

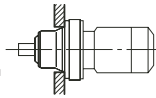

CNFM01-6125DBY ▶ CNFM8-6125Y-EP

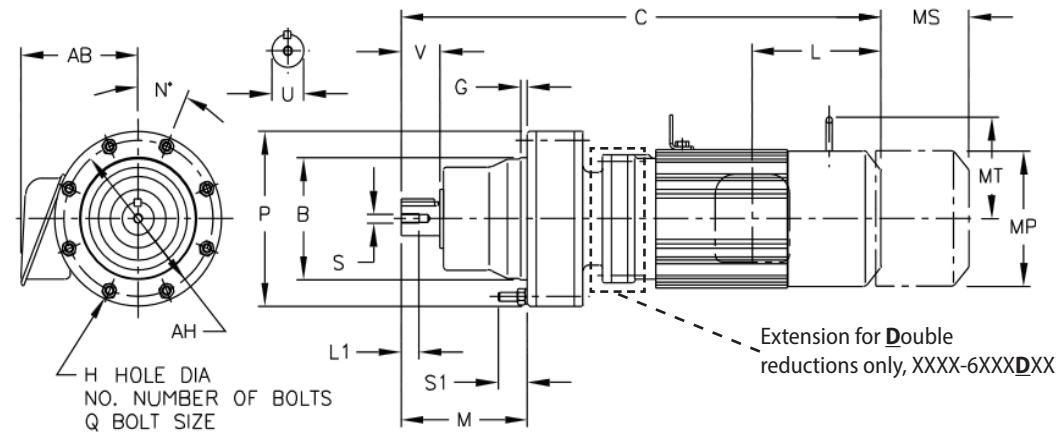

Table 1: Shaft Tolerances All dimensions are in inches (mm)

Low Speed Shaft Nominal Diameter	Tolerance
0.500 through 0.625 (12.700 through 15.875)	+0.0000 / -0.0004 (+0.000 / -0.011)
0.750 through 1.125 (19.050 through 28.757)	+0.0000 / -0.0005 (+0.000 / -0.013)
1.250 through 1.875 (31.750 through 47.625)	+0.0000 / -0.0006 (+0.000 / -0.016)
2.000 through 3.125 (50.800 through 79.375)	+0.0000 / -0.0007 (+0.000 / -0.019)
3.250 through 4.625 (82.550 through 117.475)	+0.0000 / -0.0009 (+0.000 / -0.022)
4.750 through 7.000 (120.650 through 177.800)	+0.0000 / -0.0010 (+0.000 / -0.025)

Note: CNFM units are greased for life, and can be mounted in any position.

Dimensions are in inches (mm)

Model CNFM	B	G	H	NO.	M	N	P	Q	S1	AH
6120Y 6125Y	5.51 (140)	0.55 (14)	0.43 (11)	6	5.47 (139)	60	8.03 (204)	M10	1.30 (33)	7.09 (180)

All dimensions are in inches (mm)

Model CNFM	Low Speed Shaft				
	U*	V	S	L1	Key
6120Y 6125Y	1.50 (38.1)	2.17 (55)	5/16-18UNC	0.79 (20)	3/8 x 3/8 x 1.77 (9.525 x 9.525 x 45)

Note: [A] Toleranced dimension, please refer to Table 1 above.

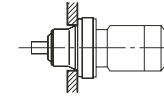

Dimensions Integral Universal F-Flange Mount

CNFM01-6125DBY ▶ CNFM8-6125Y-EP

XXXX-6XX0/6XX5 Frame sizes have equal dimensions, different ratings.

All dimensions are in inches (mm), lbs (kg)

Model	HP x P (kW x P)	AB	Without Brake				With Brake					
			C	ML	MP ^[1]	Weight lb (kg)	C	ML	MP ^[1]	MS	MT	Weight lb (kg)
CNFM01-6125DBY	1/8 x 4 (0.1 x 4)	4.63 (118)	15.20 (386)	1.38 (35)	ø4.69 (ø119)	61 (28)	16.57 (421)	2.76 (70)	ø4.88 (ø124)	2.40 (61)	-	65 (30)
CNFM01-6125DBY-AV			16.85 (428)			64 (29)	18.11 (460)					67 (30)
CNFM02-6125DAY			16.38 (416)			59 (27)	17.64 (448)					62 (28)
CNFM02-6125DBY	1/4 x 4 (0.2 x 4)		16.85 (428)			64 (29)	18.11 (460)					67 (30)
CNFM02-6125DAY-AV			17.17 (436)	2.32 (59)		62 (28)	18.43 (468)					65 (30)
CNFM02-6125DBY-AV			17.64 (448)			67 (30)	18.90 (480)					70 (32)
CNFM03-6125DBY	1/3 x 4 (0.25 x 4)		16.85 (428)			64 (29)	18.11 (460)					67 (30)
CNFM03-6125DBY-AV			17.64 (448)			67 (30)	18.90 (480)					70 (32)
CNFM05-6125Y			15.24 (387)			58 (26)	16.50 (419)					61 (28)
CNFM05-6125Y-AV	1/2 x 4 (0.4 x 4)		5.67 (144)	16.65 (423)	3.82 (97)	ø5.94 (ø151)	65 (30)	18.35 (466)				5.51 (140)
CNFM05-6125DBY		4.63 (118)	17.64 (448)	2.32 (59)	ø4.88 (ø124)	67 (30)	18.90 (480)	3.58 (91)	ø4.88 (ø124)	2.40 (61)	-	70 (32)
CNFM05-6125DBY-AV			19.25 (489)			74 (34)	20.94 (532)		ø5.94 (ø151)		3.94 (100)	80 (36)
CNFM08-6125Y		5.67 (144)	16.65 (423)	3.82 (97)	ø5.94 (ø151)	62 (28)	18.35 (466)	5.51 (140)	ø5.94 (ø151)	3.66 (93)	3.94 (100)	68 (31)
CNFM08-6125Y-AV	3/4 x 4 (0.55 x 4)	5.86 (149)	17.95 (456)	3.94 (100)	ø6.30 (ø160)	71 (32)	20.39 (518)	6.38 (162)	ø6.30 (ø160)	4.53 (115)	4.29 (109)	81 (37)
CNFM08-6125DBY		5.67 (144)	19.25 (489)	3.82 (97)	ø5.94 (ø151)	71 (33)	20.94 (532)	5.51 (140)	ø5.94 (ø151)	3.66 (93)	3.94 (100)	77 (35)
CNFM08-6125DBY-AV		5.86 (149)	20.55 (522)	3.94 (100)	ø6.30 (ø160)	82 (37)	22.99 (584)	6.38 (162)	ø6.30 (ø160)	4.53 (115)	4.29 (109)	93 (42)
CNFM1-6125Y-EP	1 x 4 (0.75 x 4)	5.98 (152)	18.39 (467)			75 (34)	20.89 (531)	6.32 (161)	ø6.22 (ø158)	4.80 (122)	4.25 (108)	85 (39)
CNFM1-6125DBY-EP			20.98 (533)			87 (40)	23.48 (597)					97 (44)
CNFM1H-6125Y-EP	1.5 x 4 (1.1 x 4)	6.16 (156)	19.45 (494)			82 (38)	22.19 (564)	6.56 (167)	ø6.57 (ø167)	5.04 (128)	4.61 (117)	94 (43)
CNFM1H-6125DBY-EP			22.05 (560)			94 (43)	24.78 (630)					106 (48)
CNFM2-6125Y-EP	2 x 4 (1.5 x 4)		19.45 (494)			85 (39)	22.19 (564)					97 (44)
CNFM2-6125DBY-EP			22.05 (560)			97 (44)	24.78 (630)					109 (50)
CNFM3-6125Y-EP	3 x 4 (2.2 x 4)	6.71 (170)	18.86 (479)	4.53 (115)	ø7.24 (ø184)	98 (45)	21.93 (557)	7.60 (193)	ø7.24 (ø184)	5.43 (138)	5.04 (128)	115 (52)
CNFM5-6125Y-EP	5 x 4 (3.7 x 4)	7.34 (186)	20.31 (516)			124 (56)	23.88 (607)	8.21 (209)	ø8.74 (ø222)	6.02 (153)	6.30 (160)	148 (67)
CNFM8-6125Y-EP	7.5 x 4 (5.5 x 4)		22.01 (559)	4.65 (118)		157 (72)	25.57 (650)					181 (83)

Note: [1] MP Dimension Symbol ø = Round Fan Cover
MP Dimension Symbol □ = Square Fan Cover

Dimensions Integral Horizontal F-Flange Mount

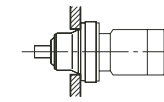

Dimensions Integral Horizontal F-Flange Mount

CHFM02-6135DAY ▶ CHFM15-6135Y-EP

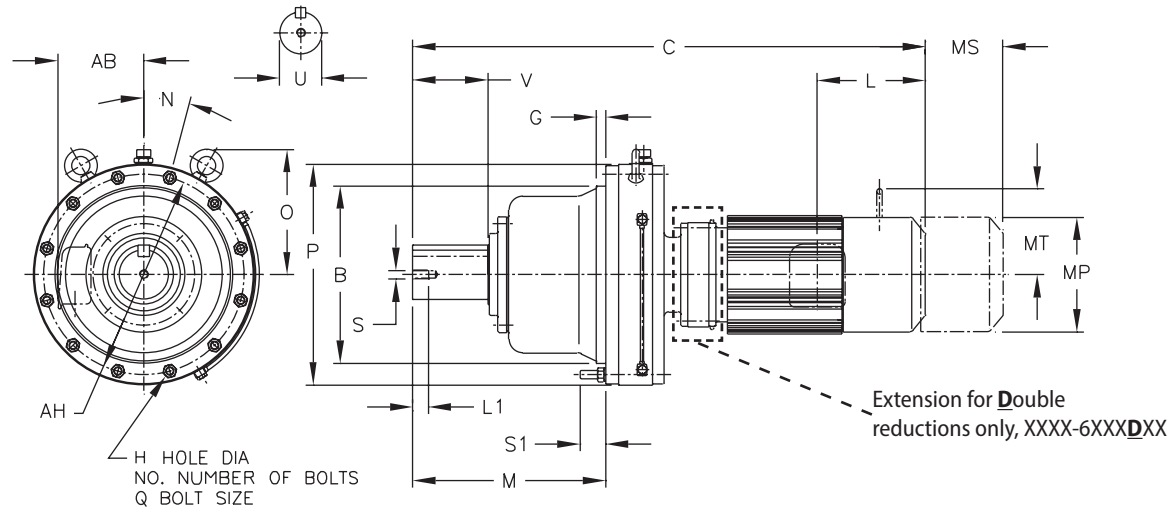

Table 1: Shaft Tolerances All dimensions are in inches (mm)

Low Speed Shaft Nominal Diameter	Tolerance Inches
0.500 through 0.625 (12.700 through 15.875)	+0.0000 / -0.0004 (+0.000 / -0.011)
0.750 through 1.125 (19.050 through 28.757)	+0.0000 / -0.0005 (+0.000 / -0.013)
1.250 through 1.875 (31.750 through 47.625)	+0.0000 / -0.0006 (+0.000 / -0.016)
2.000 through 3.125 (50.800 through 79.375)	+0.0000 / -0.0007 (+0.000 / -0.019)
3.250 through 4.625 (82.550 through 117.475)	+0.0000 / -0.0009 (+0.000 / -0.022)
4.750 through 7.000 (120.650 through 177.800)	+0.0000 / -0.0010 (+0.000 / -0.025)

Note: CHFM units are oil lubricated standard, must be installed as shown above.

Dimensions are in inches (mm)

Model CHFM	B	G	H	NO.	M	N	P	Q	S1	AH
6130Y 6135Y	6.50 (165)	0.63 (16)	0.43 (11)	6	7.01 (178)	60	9.06 (230)	M10	1.22 (31)	8.07 (205)

All dimensions are in inches (mm)

Model CHFM	Low Speed Shaft				
	U ^[A]	V	S	L1	Key
6130Y 6135Y	1.88 (47.625)	2.76 (70)	3/8-16UNC	0.79 (20)	1/2 x 1/2 x 2.17 (12.7 x 12.7 x 55)

Note: [A] Toleranced dimension, please refer to Table 1 above.

CHFM02-6135DAY ▶ CHFM15-6135Y-EP

XXXX-6XX0/6XX5 Frame sizes have equal dimensions, different ratings.

All dimensions are in inches (mm), lbs (kg)

Model	HP x P (kW x P)	AB	Without Brake				With Brake												
			C	ML	MP ^[1]	Weight lb (kg)	C	ML	MP ^[1]	MS	MT	Weight lb (kg)							
CHFM02-6135DAY	1/4 x 4 (0.2 x 4)	4.63 (118)	18.50 (470)	2.32 (59)	ø4.88 (ø124)	89 (41)	3.58 (91)	ø4.88 (ø124)	2.40 (61)	-	92 (42)								
CHFM02-6135DAY-AV			19.29 (490)			92 (42)					20.55 (522)	96 (44)							
CHFM02-6135DCY			19.41 (493)			97 (44)					20.67 (525)	100 (46)							
CHFM02-6135DCY-AV	1/3 x 4 (0.25 x 4)	4.63 (118)	20.20 (513)	2.32 (59)	ø4.88 (ø124)	100 (46)	3.58 (91)	ø4.88 (ø124)	2.40 (61)	-	103 (47)								
CHFM03-6135DCY			19.41 (493)			97 (44)					20.67 (525)	100 (46)							
CHFM03-6135DCY-AV			20.20 (513)			100 (46)					21.46 (545)	103 (47)							
CHFM05-6135DCY	1/2 x 4 (0.4 x 4)	5.67 (144)	21.81 (554)	3.82 (97)	ø5.94 (ø151)	107 (49)	5.51 (140)	ø5.94 (ø151)	3.66 (93)	3.94 (100)	113 (52)								
CHFM05-6135DCY-AV	18.78 (477)		98 (45)			20.47 (520)					104 (48)								
CHFM08-6135Y	3/4 x 4 (0.55 x 4)	5.86 (149)	20.08 (510)	3.94 (100)	ø6.30 (ø160)	107 (49)	6.38 (162)	ø6.30 (ø160)	4.53 (115)	4.29 (109)	118 (54)								
CHFM08-6135Y-AV			5.67 (144)			21.81 (554)					3.82 (97)	ø5.94 (ø151)	105 (48)	23.50 (597)	5.51 (140)	ø5.94 (ø151)	3.66 (93)	3.94 (100)	110 (50)
CHFM08-6135DCY			5.86 (149)			23.11 (587)					3.94 (100)	ø6.30 (ø160)	115 (53)	25.55 (649)	6.38 (162)	ø6.30 (ø160)	4.53 (115)	4.29 (109)	126 (57)
CHFM08-6135DCY-AV	1 x 4 (0.75 x 4)	5.98 (152)	20.51 (521)	3.82 (97)	ø6.22 (ø158)	112 (51)	6.32 (161)	ø6.22 (ø158)	4.80 (122)	4.25 (108)	122 (56)								
CHFM1-6135Y-EP			23.54 (598)			120 (55)					26.04 (662)	130 (59)							
CHFM1-6135DCY-EP			20.51 (521)			119 (54)					24.31 (618)	139 (63)							
CHFM1H-6135Y-EP	1.5 x 4 (1.1 x 4)	6.16 (156)	21.57 (548)	3.82 (97)	ø6.57 (ø167)	119 (54)	6.56 (167)	ø6.57 (ø167)	5.04 (128)	4.61 (117)	139 (63)								
CHFM1H-6135DCY-EP			24.61 (625)			128 (58)					27.34 (695)	133 (61)							
CHFM2-6135Y-EP			21.57 (548)			122 (56)					24.31 (618)	142 (65)							
CHFM2-6135DCY-EP	2 x 4 (1.5 x 4)	6.71 (170)	24.61 (625)	4.53 (115)	ø7.24 (ø184)	131 (60)	7.60 (193)	ø7.24 (ø184)	5.43 (138)	5.04 (128)	150 (68)								
CHFM3-6135Y-EP	20.98 (533)		133 (61)			24.06 (611)					163 (74)								
CHFM3-6135DCY-EP	25.43 (646)		147 (67)			28.50 (724)					181 (83)								
CHFM5-6135Y-EP	3 x 4 (2.2 x 4)	7.34 (186)	22.24 (565)	4.65 (118)	ø8.74 (ø222)	157 (72)	8.21 (209)	ø8.74 (ø222)	6.02 (153)	6.30 (160)	216 (98)								
CHFM8-6135Y-EP	23.94 (608)		192 (87)			27.50 (699)					263 (119)								
CHFM10-6135Y-EP	5 x 4 (3.7 x 4)	9.04 (230)	25.43 (646)	5.43 (138)	ø10.24 (ø260)	218 (99)	9.57 (243)	ø10.24 (ø260)	7.44 (189)	7.32 (186)	275 (125)								
CHFM15-6135Y-EP	27.87 (708)		231 (105)			32.01 (813)					275 (125)								

Note: [1] MP Dimension Symbol ø = Round Fan Cover
MP Dimension Symbol □ = Square Fan Cover

Dimensions Integral Horizontal F-Flange Mount

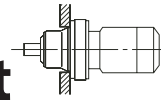

CHFM02-6145DBY ▶ CHFM20-6145Y-EP

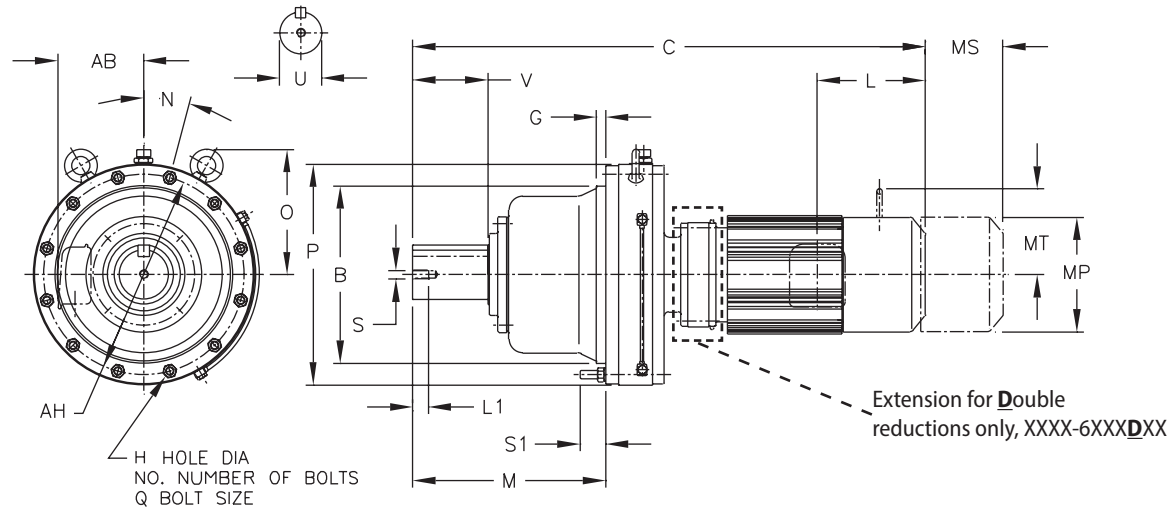

Table 1: Shaft Tolerances All dimensions are in inches (mm)

Low Speed Shaft Nominal Diameter	Tolerance Inches
0.500 through 0.625 (12.700 through 15.875)	+0.0000 / -0.0004 (+0.000 / -0.011)
0.750 through 1.125 (19.050 through 28.757)	+0.0000 / -0.0005 (+0.000 / -0.013)
1.250 through 1.875 (31.750 through 47.625)	+0.0000 / -0.0006 (+0.000 / -0.016)
2.000 through 3.125 (50.800 through 79.375)	+0.0000 / -0.0007 (+0.000 / -0.019)
3.250 through 4.625 (82.550 through 117.475)	+0.0000 / -0.0009 (+0.000 / -0.022)
4.750 through 7.000 (120.650 through 177.800)	+0.0000 / -0.0010 (+0.000 / -0.025)

Note: CHFM units are oil lubricated standard, must be installed as shown above.

Dimensions are in inches (mm)

Model CHFM	B	G	H	NO.	M	N	P	Q	S1	AH
6140Y	6.50	0.63	0.43	6	7.80	60	9.06	M10	1.22	8.07
6145Y	(165)	(16)	(11)		(198)		(230)		(31)	(205)

All dimensions are in inches (mm)

Model CHFM	Low Speed Shaft				
	U ^[A]	V	S	L1	Key
6140Y	1.88	3.54	3/8-16UNC	0.79	1/2 x 1/2 x 2.95
6145Y	(47.625)	(90)		(20)	(12.7 x 12.7 x 75)

Note: [A] Toleranced dimension, please refer to Table 1 above.

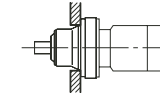

Dimensions Integral Horizontal F-Flange Mount

CHFM02-6145DBY ▶ CHFM20-6145Y-EP

XXXX-6XX0/6XX5 Frame sizes have equal dimensions, different ratings.
All dimensions are in inches (mm), lbs (kg)

Model	HP x P (kW x P)	AB	Without Brake				With Brake					
			C	ML	MP ^[1]	Weight lb (kg)	C	ML	MP ^[1]	MS	MT	Weight lb (kg)
CHFM02-6145DBY	1/4 x 4 (0.2 x 4)	4.63 (118)	19.65 (499)	2.32 (59)	ø4.88 (ø124)	94 (43)	20.91 (531)	3.58 (91)	ø4.88 (ø124)	2.40 (61)	-	97 (44)
CHFM02-6145DBY-AV	20.43 (519)		97 (44)			101 (46)						
CHFM03-6145DBY	1/3 x 4 (0.25 x 4)	4.63 (118)	19.65 (499)	2.32 (59)	ø4.88 (ø124)	94 (43)	20.91 (531)	3.58 (91)	ø4.88 (ø124)	2.40 (61)	-	97 (44)
CHFM03-6145DBY-AV	20.43 (519)		97 (44)			101 (46)						
CHFM05-6145DBY	1/2 x 4 (0.4 x 4)	5.67 (144)	22.05 (560)	3.82 (97)	ø5.94 (ø151)	105 (48)	23.74 (603)	5.51 (140)	ø5.94 (ø151)	3.66 (93)	3.94 (100)	110 (50)
CHFM05-6145DBY-AV	102 (47)		108 (49)									
CHFM08-6145DBY	3/4 x 4 (0.55 x 4)	5.86 (149)	23.35 (593)	3.94 (100)	ø6.30 (ø160)	113 (51)	25.79 (655)	6.38 (162)	ø6.30 (ø160)	4.53 (115)	4.29 (109)	124 (56)
CHFM08-6145DBY-AV	23.78 (604)		118 (54)			128 (58)						
CHFM1-6145Y-EP	1 x 4 (0.75 x 4)	5.98 (152)	21.30 (541)	3.82 (97)	ø6.22 (ø158)	114 (52)	23.80 (605)	6.32 (161)	ø6.22 (ø158)	4.80 (122)	4.25 (108)	124 (57)
CHFM1-6145DBY-EP	23.78 (604)		118 (54)			128 (58)						
CHFM1H-6145Y-EP	1.5 x 4 (1.1 x 4)	6.16 (156)	22.36 (568)	3.82 (97)	ø6.57 (ø167)	121 (55)	25.10 (638)	6.56 (167)	ø6.57 (ø167)	5.04 (128)	4.61 (117)	133 (60)
CHFM1H-6145DBY-EP	24.84 (631)		125 (57)			137 (62)						
CHFM2-6145Y-EP	2 x 4 (1.5 x 4)	6.16 (156)	22.36 (568)	3.82 (97)	ø6.57 (ø167)	124 (57)	25.10 (638)	6.56 (167)	ø6.57 (ø167)	5.04 (128)	4.61 (117)	136 (62)
CHFM2-6145DBY-EP			24.84 (631)			128 (58)						140 (64)
CHFM2-6145DCY-EP			25.39 (645)			131 (60)						142 (65)
CHFM3-6145Y-EP	3 x 4 (2.2 x 4)	6.71 (170)	21.77 (553)	4.53 (115)	ø7.24 (ø184)	136 (62)	24.84 (631)	7.60 (193)	ø7.24 (ø184)	5.43 (138)	5.04 (128)	152 (69)
CHFM3-6145DBY-EP			25.67 (652)			144 (66)						161 (73)
CHFM3-6145DCY-EP			26.22 (666)			147 (67)						163 (74)
CHFM5-6145Y-EP	5 x 4 (3.7 x 4)	7.34 (186)	23.03 (585)	4.65 (118)	ø8.74 (ø222)	160 (73)	26.59 (676)	8.21 (209)	ø8.74 (ø222)	6.02 (153)	6.30 (160)	184 (84)
CHFM5-6145DBY-EP	24.72 (628)		194 (88)			218 (99)						
CHFM10-6145Y-EP	10 x 4 (7.5 x 4)	9.04 (230)	26.22 (666)	5.43 (138)	ø10.24 (ø260)	221 (100)	30.35 (771)	9.57 (243)	ø10.24 (ø260)	7.44 (189)	7.32 (186)	265 (120)
CHFM10-6145DBY-EP	28.66 (728)		233 (106)			278 (126)						
CHFM15-6145Y-EP	15 x 4 (11 x 4)	10.26 (261)	31.10 (790)	7.01 (178)	ø12.49 (ø317)	314 (143)	36.40 (925)	12.30 (313)	ø12.61 (ø320)	9.53 (242)	-	400 (182)
CHFM15-6145DBY-EP												

Note: [1] MP Dimension Symbol ø = Round Fan Cover
MP Dimension Symbol □ = Square Fan Cover

Dimensions Integral Horizontal F-Flange Mount

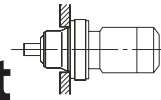

CHFM05-6165DCY ▶ CHFM30-6165Y-EP

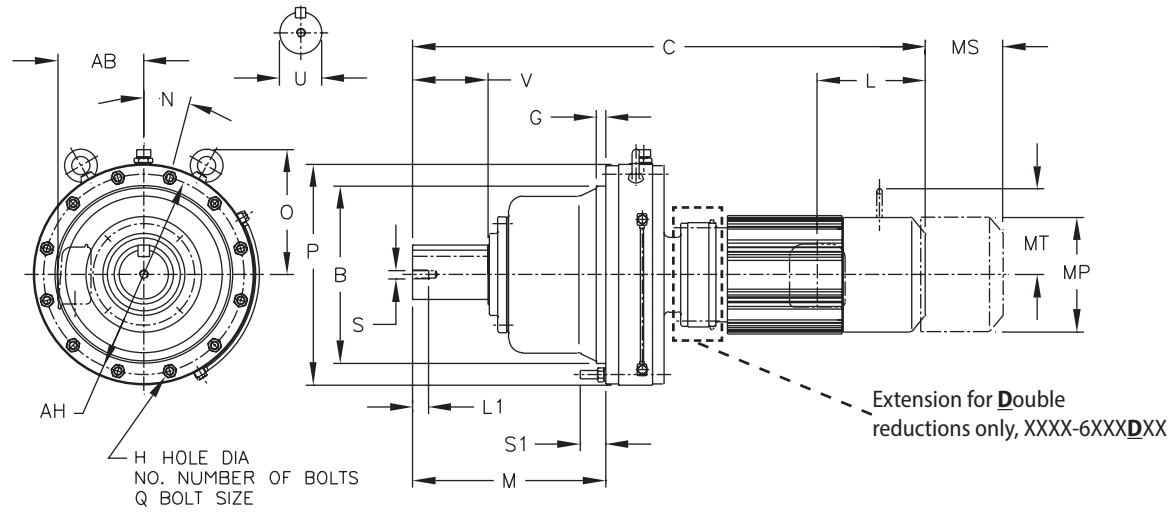

Table 1: Shaft Tolerances All dimensions are in inches (mm)

Low Speed Shaft Nominal Diameter	Tolerance Inches
0.500 through 0.625 (12.700 through 15.875)	+0.0000 / -0.0004 (+0.000 / -0.011)
0.750 through 1.125 (19.050 through 28.757)	+0.0000 / -0.0005 (+0.000 / -0.013)
1.250 through 1.875 (31.750 through 47.625)	+0.0000 / -0.0006 (+0.000 / -0.016)
2.000 through 3.125 (50.800 through 79.375)	+0.0000 / -0.0007 (+0.000 / -0.019)
3.250 through 4.625 (82.550 through 117.475)	+0.0000 / -0.0009 (+0.000 / -0.022)
4.750 through 7.000 (120.650 through 177.800)	+0.0000 / -0.0010 (+0.000 / -0.025)

Note: CHFM units are oil lubricated standard, must be installed as shown above.

Dimensions are in inches (mm)

Model CHFM	B	G	H	NO.	M	N	P	Q	S1	AH
6160Y	7.87	0.39	0.55	6	8.74	30	11.81	M12	1.38	10.63
6165Y	(200)	(10)	(14)		(222)		(300)		(35)	(270)

All dimensions are in inches (mm)

Model CHFM	Low Speed Shaft				
	U ^[A]	V	S	L1	Key
6160Y	2.25	3.54	3/8-16UNC	0.79	1/2 x 1/2 x 2.95
6165Y	(57.15)	(90)		(20)	(12.7 x 12.7 x 75)

Note: [A] Toleranced dimension, please refer to Table 1 above.

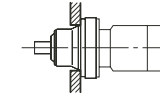

Dimensions Integral Horizontal F-Flange Mount

CHFM05-6165DCY ▶ CHFM30-6165Y-EP

XXXX-6XX0/6XX5 Frame sizes have equal dimensions, different ratings.

All dimensions are in inches (mm), lbs (kg)

Model	HP x P (kW x P)	AB	Without Brake				With Brake					
			C	ML	MP ^[1]	Weight lb (kg)	C	ML	MP ^[1]	MS	MT	Weight lb (kg)
CHFM05-6165DCY	1/2 x 4 (0.4 x 4)	4.63 (118)	23.23 (590)	2.32 (59)	ø4.88 (ø124)	194 (88)	24.49 (622)	3.58 (91)	ø4.88 (ø124)	2.40 (61)	-	197 (90)
CHFM05-6165DCY-AV		5.67 (144)	24.65 (626)	3.82 (97)	ø5.94 (ø151)	201 (92)	26.34 (669)	5.51 (140)	ø5.94 (ø151)	3.66 (93)	3.94 (100)	207 (94)
CHFM08-6165DCY	3/4 x 4 (0.55 x 4)	5.86 (149)	25.94 (659)	3.94 (100)	ø6.30 (ø160)	199 (90)						205 (93)
CHFM08-6165DCY-AV		5.98 (152)	26.38 (670)		ø6.22 (ø158)	207 (94)	28.39 (721)	6.38 (162)	ø6.30 (ø160)	4.53 (115)	4.29 (109)	218 (99)
CHFM1-6165DCY-EP	1 x 4 (0.75 x 4)				□6.22 (□158)	212 (96)	28.88 (734)	6.32 (161)	□6.22 (□158)	4.80 (122)	4.25 (108)	222 (101)
CHFM1H-6165Y-EP	1.5 x 4 (1.1 x 4)		24.25 (616)			179 (81)	26.99 (686)					191 (87)
CHFM1H-6165DCY-EP		6.16 (156)	27.44 (697)	3.82 (97)	□6.57 (□167)	219 (100)	30.18 (767)	6.56 (167)	□6.57 (□167)	5.04 (128)	4.61 (117)	230 (105)
CHFM2-6165Y-EP	2 x 4 (1.5 x 4)		24.25 (616)			182 (83)	26.99 (686)					194 (88)
CHFM2-6165DCY-EP			27.44 (697)			222 (101)	30.18 (767)					234 (106)
CHFM3-6165Y-EP	3 x 4 (2.2 x 4)	6.71 (170)	23.66 (601)	4.53 (115)	□7.24 (□184)	192 (87)	26.73 (679)	7.60 (193)	□7.24 (□184)	5.43 (138)	5.04 (128)	209 (95)
CHFM3-6165DCY-EP			26.85 (682)			235 (107)	29.92 (760)					252 (114)
CHFM5-6165Y-EP	5 x 4 (3.7 x 4)		25.12 (638)			217 (99)	28.68 (729)					241 (109)
CHFM5-6165DCY-EP		7.34 (186)	28.31 (719)	4.65 (118)	□8.74 (□222)	260 (118)	31.87 (810)	8.21 (209)	□8.74 (□222)	6.02 (153)	6.30 (160)	284 (129)
CHFM8-6165Y-EP	7.5 x 4 (5.5 x 4)		26.81 (681)			251 (114)	30.37 (772)					275 (125)
CHFM8-6165DCY-EP			30.00 (762)			294 (134)	33.56 (853)					318 (145)
CHFM10-6165Y-EP	10 x 4 (7.5 x 4)	9.04 (230)	28.27 (718)	5.43 (138)	□10.24 (□260)	279 (127)	32.40 (823)	9.57 (243)	□10.24 (□260)	7.44 (189)	7.32 (186)	323 (147)
CHFM15-6165Y-EP	15 x 4 (11 x 4)		30.71 (780)			291 (132)	34.84 (885)					335 (152)
CHFM20-6165Y-EP	20 x 4 (15 x 4)	10.26 (261)	32.99 (838)	7.01 (178)	ø12.49 (ø317)	375 (170)	38.29 (973)	12.30 (313)	ø12.61 (ø320)	9.53 (242)		461 (209)
CHFM25-6165Y-EP	25 x 4 (18.5 x 4)											
CHFM30-6165Y-EP	30 x 4 (22 x 4)	13.39 (340)	37.17 (944)	9.06 (230)	ø15.12 (ø384)	652 (296)	44.02 (1118)	15.91 (404)	ø15.28 (ø388)	12.13 (308)		749 (340)

Note: [1] MP Dimension Symbol ø = Round Fan Cover
MP Dimension Symbol □ = Square Fan Cover

Dimensions Integral Horizontal F-Flange Mount

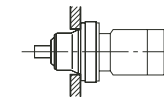

Dimensions Integral Horizontal F-Flange Mount

CHFM05-6175DCY ▶ CHFM40-6175Y-EP

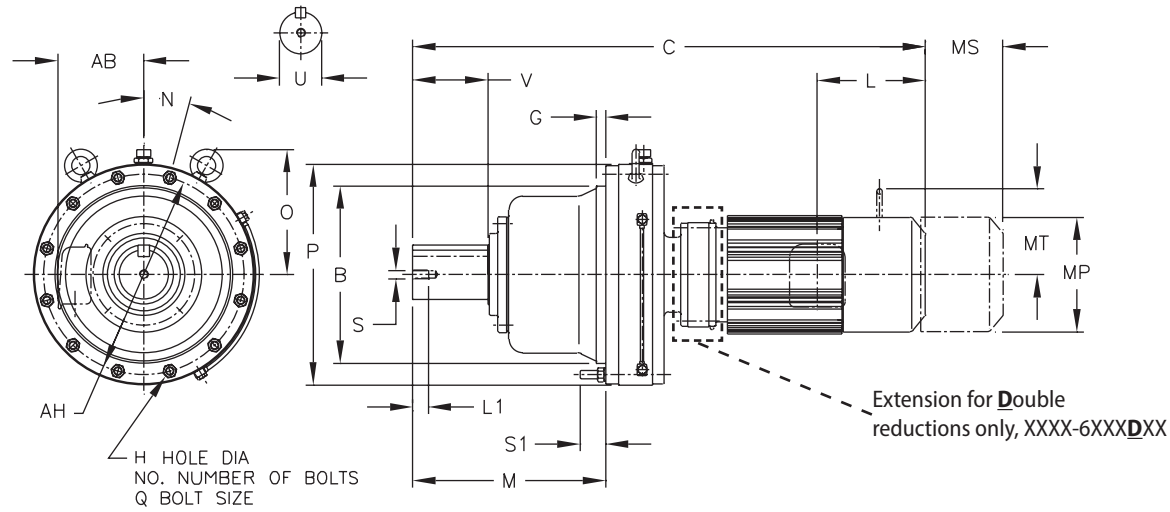

Table 1: Shaft Tolerances All dimensions are in inches (mm)

Low Speed Shaft Nominal Diameter	Tolerance Inches
0.500 through 0.625 (12.700 through 15.875)	+0.0000 / -0.0004 (+0.000 / -0.011)
0.750 through 1.125 (19.050 through 28.757)	+0.0000 / -0.0005 (+0.000 / -0.013)
1.250 through 1.875 (31.750 through 47.625)	+0.0000 / -0.0006 (+0.000 / -0.016)
2.000 through 3.125 (50.800 through 79.375)	+0.0000 / -0.0007 (+0.000 / -0.019)
3.250 through 4.625 (82.550 through 117.475)	+0.0000 / -0.0009 (+0.000 / -0.022)
4.750 through 7.000 (120.650 through 177.800)	+0.0000 / -0.0010 (+0.000 / -0.025)

Note: CHFM units are oil lubricated standard, must be installed as shown above.

Dimensions are in inches (mm)

Model CHFM	B	G	H	NO.	M	N	P	Q	S1	AH
6170Y 6175Y	9.84 (250)	0.47 (12)	0.55 (14)	8	10.31 (262)	22.5	13.39 (340)	M12	1.61 (41)	11.81 (300)

All dimensions are in inches (mm)

Model CHFM	Low Speed Shaft				
	U ^[A]	V	S	L1	Key
6170Y 6175Y	2.75 (69.85)	3.54 (90)	1/2-13UNC	0.94 (24)	5/8 x 5/8 x 3.15 (15.87 x 15.87 x 80)

Note: [A] Toleranced dimension, please refer to Table 1 above.

CHFM05-6175DCY ▶ CHFM40-6175Y-EP

XXXX-6XX0/6XX5 Frame sizes have equal dimensions, different ratings.

All dimensions are in inches (mm), lbs (kg)

Model	HP x P (kW x P)	AB	Without Brake				With Brake					
			C	ML	MP ^[1]	Weight lb (kg)	C	ML	MP ^[1]	MS	MT	Weight lb (kg)
CHFM05-6175DCY	1/2 x 4 (0.4 x 4)	4.63 (118)	25.08 (637)	2.32 (59)	ø4.88 (ø124)	245 (111)	26.34 (669)	3.58 (91)	ø4.88 (ø124)	2.40 (61)	-	248 (113)
CHFM05-6175DCY-AV		5.67 (144)	26.50 (673)	3.82 (97)	ø5.94 (ø151)	252 (115)	28.19 (716)	5.51 (140)	ø5.94 (ø151)	3.66 (93)	3.94 (100)	258 (117)
CHFM08-6175DCY	3/4 x 4 (0.55 x 4)	5.86 (149)	27.80 (706)	3.94 (100)	ø6.30 (ø160)	250 (113)						269 (122)
CHFM08-6175DCY-AV												269 (122)
CHFM1-6175DAY-EP	1 x 4 (0.75 x 4)	5.98 (152)	27.52 (699)	3.82 (97)	ø6.22 (ø158)	237 (108)	30.02 (763)	6.32 (161)	ø6.22 (ø158)	4.80 (122)	4.25 (108)	247 (112)
CHFM1-6175DCY-EP			28.23 (717)			263 (119)	30.73 (781)					273 (124)
CHFM1H-6175DCY-EP	1.5 x 4 (1.1 x 4)	6.16 (156)	29.29 (744)	ø6.57 (ø167)	270 (123)	32.03 (814)	6.56 (167)	ø6.57 (ø167)	5.04 (128)	4.61 (117)	281 (128)	
CHFM2-6175DAY-EP	2 x 4 (1.5 x 4)		28.58 (726)		247 (112)	31.32 (796)					259 (118)	
CHFM2-6175DCY-EP			29.29 (744)		273 (124)	32.03 (814)	284 (129)					
CHFM3-6175DCY-EP	3 x 4 (2.2 x 4)	6.71 (170)	28.70 (729)	4.53 (115)	ø7.24 (ø184)	286 (130)	31.77 (807)	7.60 (193)	ø7.24 (ø184)	5.43 (138)	5.04 (128)	302 (137)
CHFM5-6175Y-EP	5 x 4 (3.7 x 4)	7.34 (186)	27.05 (687)	4.65 (118)	ø8.74 (ø222)	287 (130)	30.61 (778)	8.21 (209)	ø8.74 (ø222)	6.02 (153)	6.30 (160)	311 (141)
CHFM5-6175DCY-EP			30.16 (766)			311 (141)	33.72 (857)					335 (152)
CHFM8-6175Y-EP	7.5 x 4 (5.5 x 4)		28.74 (730)			321 (146)	32.30 (821)					345 (157)
CHFM8-6175DCY-EP			31.85 (809)			345 (157)	35.41 (900)					369 (168)
CHFM10-6175Y-EP	10 x 4 (7.5 x 4)	9.04 (230)	29.57 (751)	5.43 (138)	ø10.24 (ø260)	350 (159)	33.70 (856)	9.57 (243)	ø10.24 (ø260)	7.44 (189)	7.32 (186)	394 (179)
CHFM15-6175Y-EP	15 x 4 (11 x 4)		32.01 (813)			362 (165)	36.14 (918)					406 (185)
CHFM20-6175Y-EP	20 x 4 (15 x 4)	10.26 (261)	34.72 (882)	7.01 (178)	ø12.49 (ø317)	443 (201)	40.02 (1017)	12.30 (313)	ø12.61 (ø320)	9.53 (242)	-	529 (240)
CHFM25-6175Y-EP	25 x 4 (18.5 x 4)	13.39 (340)	38.90 (988)	9.06 (230)	ø15.12 (ø384)	722 (328)	45.75 (1162)	15.91 (404)	ø15.28 (ø388)	12.13 (308)	-	819 (372)
CHFM30-6175Y-EP	30 x 4 (22 x 4)											
CHFM40-6175Y-EP	40 x 4 (30 x 4)		43.78 (1112)			835 (379)	50.63 (1286)					932 (423)

Note: [1] MP Dimension Symbol ø = Round Fan Cover
MP Dimension Symbol □ = Square Fan Cover

Dimensions Integral Horizontal F-Flange Mount

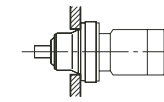

Dimensions Integral Horizontal F-Flange Mount

CHFM1-6185DBY-EP ▶ CHFM50-6185Y-EP

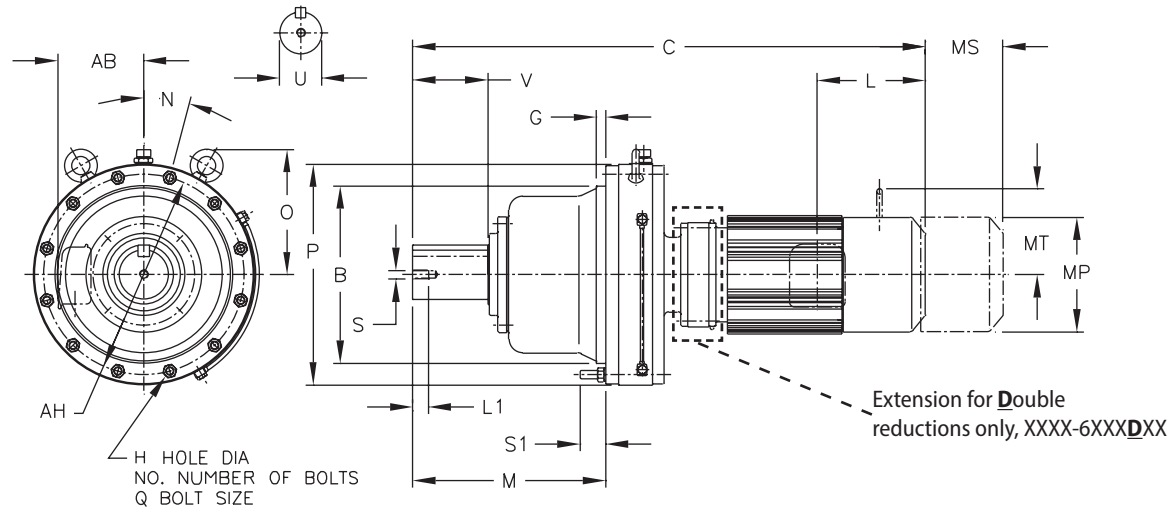

Table 1: Shaft Tolerances All dimensions are in inches (mm)

Low Speed Shaft Nominal Diameter	Tolerance Inches
0.500 through 0.625 (12.700 through 15.875)	+0.0000 / -0.0004 (+0.000 / -0.011)
0.750 through 1.125 (19.050 through 28.757)	+0.0000 / -0.0005 (+0.000 / -0.013)
1.250 through 1.875 (31.750 through 47.625)	+0.0000 / -0.0006 (+0.000 / -0.016)
2.000 through 3.125 (50.800 through 79.375)	+0.0000 / -0.0007 (+0.000 / -0.019)
3.250 through 4.625 (82.550 through 117.475)	+0.0000 / -0.0009 (+0.000 / -0.022)
4.750 through 7.000 (120.650 through 177.800)	+0.0000 / -0.0010 (+0.000 / -0.025)

Note: CHFM units are oil lubricated standard, must be installed as shown above.

Dimensions are in inches (mm)

Model CHFM	B	G	H	NO.	M	N	P	Q	S1	AH
6180Y	11.02	0.47	0.55	8	11.77	22.5	14.57	M12	1.50	12.99
6185Y	(280)	(12)	(14)		(299)		(370)		(38)	(330)

All dimensions are in inches (mm)

Model CHFM	Low Speed Shaft				
	U ^[A]	V	S	L1	Key
6180Y	3.13	4.33	1/2-13UNC	0.94	3/4 x 3/4 x 3.74
6185Y	(79.375)	(110)		(24)	(19.05 x 19.05 x 95)

Note: [A] Toleranced dimension, please refer to Table 1 above.

CHFM1-6185DBY-EP ▶ CHFM50-6185Y-EP

XXXX-6XX0/6XX5 Frame sizes have equal dimensions, different ratings.

All dimensions are in inches (mm), lbs (kg)

Model	HP x P (kW x P)	AB	Without Brake				With Brake					
			C	ML	MP ^[1]	Weight lb (kg)	C	ML	MP ^[1]	MS	MT	Weight lb (kg)
CHFM1-6185DBY-EP	1 x 4 (0.75 x 4)	5.98 (152)	30.59 (777)	3.82 (97)	□6.22 (□158)	354 (161)	33.09 (841)	6.32 (161)	□6.22 (□158)	4.80 (122)	4.25 (108)	364 (166)
CHFM1H-6185DBY-EP	1.5 x 4 (1.1 x 4)	6.16 (156)	31.65 (804)		□6.57 (□167)	361 (164)	34.39 (874)	6.56 (167)	□6.57 (□167)	5.04 (128)	4.61 (117)	373 (169)
CHFM2-6185DAY-EP	2 x 4 (1.5 x 4)		30.79 (782)	327 (149)	33.52 (852)	376 (171)	34.39 (874)		376 (171)			
CHFM2-6185DBY-EP	2 x 4 (1.5 x 4)	6.71 (170)	31.65 (804)	4.53 (115)	□7.24 (□184)	376 (171)	34.13 (867)	7.60 (193)	□7.24 (□184)	5.43 (138)	5.04 (128)	393 (178)
CHFM3-6185DBY-EP	3 x 4 (2.2 x 4)		31.06 (789)		376 (171)	34.13 (867)	7.60 (193)	5.43 (138)	5.04 (128)	393 (178)		
CHFM5-6185Y-EP	5 x 4 (3.7 x 4)	7.34 (186)	28.50 (724)	4.65 (118)	□8.74 (□222)	361 (164)	32.07 (815)	8.21 (209)	□8.74 (□222)	6.02 (153)	6.30 (160)	385 (175)
CHFM5-6185DBY-EP	5 x 4 (3.7 x 4)		32.32 (821)			400 (182)	35.89 (912)					424 (193)
CHFM8-6185Y-EP	7.5 x 4 (5.5 x 4)	9.04 (230)	30.20 (767)	5.43 (138)	□10.24 (□260)	395 (179)	33.76 (858)	9.57 (243)	□10.24 (□260)	7.44 (189)	7.32 (186)	418 (190)
CHFM8-6185DBY-EP	7.5 x 4 (5.5 x 4)		34.02 (864)			434 (197)	37.58 (955)					458 (208)
CHFM10-6185Y-EP	10 x 4 (7.5 x 4)	10.26 (261)	31.14 (791)	7.01 (178)	□12.49 (□317)	425 (193)	35.28 (896)	12.30 (313)	□12.61 (□320)	9.53 (242)		469 (213)
CHFM10-6185DBY-EP	10 x 4 (7.5 x 4)		35.51 (902)			461 (209)	39.65 (1007)					505 (229)
CHFM15-6185Y-EP	15 x 4 (11 x 4)	13.39 (340)	33.58 (853)	9.06 (230)	□15.12 (□384)	438 (199)	37.72 (958)	15.91 (404)	□15.28 (□388)	12.13 (308)		482 (219)
CHFM15-6185DBY-EP	15 x 4 (11 x 4)		37.95 (964)			474 (215)	42.09 (1069)					518 (235)
CHFM20-6185Y-EP	20 x 4 (15 x 4)	45.24 (1149)	36.18 (919)	9.06 (230)	□15.12 (□384)	518 (235)	41.48 (1054)	12.30 (313)	□12.61 (□320)	9.53 (242)		604 (274)
CHFM25-6185Y-EP	25 x 4 (18.5 x 4)		40.35 (1025)			795 (361)	47.20 (1199)					892 (405)
CHFM30-6185Y-EP	30 x 4 (22 x 4)	45.24 (1149)	36.18 (919)	9.06 (230)	□15.12 (□384)	908 (412)	52.09 (1323)	15.91 (404)	□15.28 (□388)	12.13 (308)		1005 (456)
CHFM40-6185Y-EP	40 x 4 (30 x 4)					976 (443)	-					-
CHFM50-6185Y-EP	50 x 4 (37 x 4)											

Note: [1] MP Dimension Symbol ϕ = Round Fan Cover
MP Dimension Symbol \square = Square Fan Cover

Dimensions Integral Horizontal F-Flange Mount

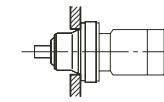

Dimensions Integral Horizontal F-Flange Mount

CHFM1-6195DAY-EP ▶ CHFM60-6195Y-EP

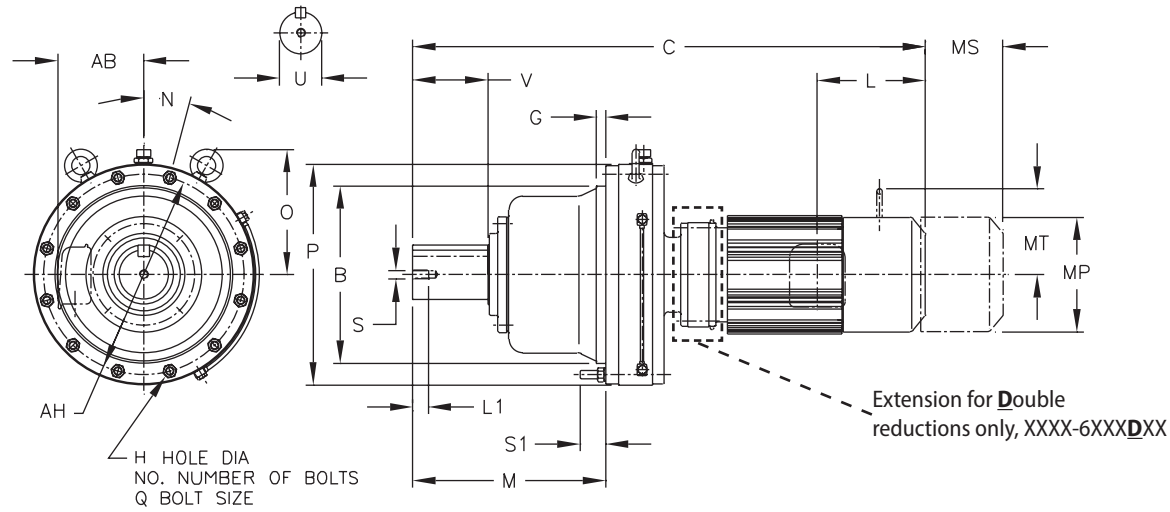

Table 1: Shaft Tolerances All dimensions are in inches (mm)

Low Speed Shaft Nominal Diameter	Tolerance Inches
0.500 through 0.625 (12.700 through 15.875)	+0.0000 / -0.0004 (+0.000 / -0.011)
0.750 through 1.125 (19.050 through 28.757)	+0.0000 / -0.0005 (+0.000 / -0.013)
1.250 through 1.875 (31.750 through 47.625)	+0.0000 / -0.0006 (+0.000 / -0.016)
2.000 through 3.125 (50.800 through 79.375)	+0.0000 / -0.0007 (+0.000 / -0.019)
3.250 through 4.625 (82.550 through 117.475)	+0.0000 / -0.0009 (+0.000 / -0.022)
4.750 through 7.000 (120.650 through 177.800)	+0.0000 / -0.0010 (+0.000 / -0.025)

Note: CHFM units are oil lubricated standard, must be installed as shown above.

Dimensions are in inches (mm)

Model CHFM	B	G	H	NO.	M	N	P	Q	S1	AH
6190Y	12.60	0.39	0.55	12	14.37	15	16.93	M12	1.61	14.96
6195Y	(320)	(10)	(14)		(365)		(430)		(41)	(380)

All dimensions are in inches (mm)

Model CHFM	Low Speed Shaft				
	U ^[A]	V	S	L1	Key
6190Y	3.63	5.31	3/4-10UNC	1.34	7/8 x 7/8 x 4.92
6195Y	(92.075)	(135)		(34)	(22.225 x 22.225 x 125)

Note: [A] Toleranced dimension, please refer to Table 1 above.

CHFM1-6195DAY-EP ▶ CHFM60-6195Y-EP

XXXX-6XX0/6XX5 Frame sizes have equal dimensions, different ratings.

All dimensions are in inches (mm), lbs (kg)

Model	HP x P (kW x P)	AB	Without Brake				With Brake					
			C	ML	MP ^[1]	Weight lb (kg)	C	ML	MP ^[1]	MS	MT	Weight lb (kg)
CHFM1-6195DAY-EP	1 x 4 (0.75 x 4)	5.98 (152)	32.95 (837)	3.82 (97)	□6.22 (□158)	474 (215)	35.45 (901)	6.32 (161)	□6.22 (□158)	4.80 (122)	4.25 (108)	484 (220)
CHFM1H-6195DAY-EP	1.5 x 4 (1.1 x 4)	6.16 (156)	34.02 (864)		□6.57 (□167)	481 (219)	36.75 (934)	6.56 (167)	□6.57 (□167)	5.04 (128)	4.61 (117)	493 (224)
CHFM2-6195DAY-EP	2 x 4 (1.5 x 4)		6.71 (170)	33.43 (849)	4.53 (115)	□7.24 (□184)	484 (220)	7.60 (193)	□7.24 (□184)	5.43 (138)	5.04 (128)	496 (225)
CHFM3-6195DAY-EP	3 x 4 (2.2 x 4)	34.06 (865)		506 (230)		514 (233)						
CHFM3-6195DBY-EP											523 (237)	
CHFM5-6195DAY-EP	5 x 4 (3.7 x 4)	7.34 (186)	34.88 (886)	4.65 (118)	□8.74 (□222)	523 (237)	38.44 (977)	8.21 (209)	□8.74 (□222)	6.02 (153)	6.30 (160)	547 (248)
CHFM5-6195DBY-EP			35.31 (897)			530 (241)	38.88 (988)					554 (252)
CHFM8-6195Y-EP	7.5 x 4 (5.5 x 4)	9.04 (230)	33.78 (858)	5.43 (138)	□10.24 (□260)	533 (242)	37.34 (949)	9.57 (243)	□10.24 (□260)	7.44 (189)	7.32 (186)	557 (253)
CHFM8-6195DAY-EP			36.57 (929)			557 (253)	40.14 (1020)					580 (264)
CHFM8-6195DBY-EP			37.01 (940)			564 (256)	38.15 (969)					588 (267)
CHFM10-6195Y-EP	10 x 4 (7.5 x 4)	10.26 (261)	34.02 (864)	7.01 (178)	□12.49 (□317)	591 (268)	42.64 (1083)	12.30 (313)	□12.61 (□320)	9.53 (242)		608 (276)
CHFM10-6195DBY-EP			38.50 (978)			576 (262)	40.59 (1031)					635 (288)
CHFM15-6195Y-EP	15 x 4 (11 x 4)	13.39 (340)	36.46 (926)	9.06 (230)	□15.12 (□384)	604 (274)	45.08 (1145)	15.91 (404)	□15.28 (□388)	12.13 (308)		621 (282)
CHFM15-6195DBY-EP			40.94 (1040)			604 (274)	45.08 (1145)					648 (294)
CHFM20-6195Y-EP	20 x 4 (15 x 4)	16.33 (415)	39.17 (995)	16.81 (427)	□18.66 (□474)	655 (297)	44.47 (1130)	-	-	-	-	741 (336)
CHFM20-6195DBY-EP			43.39 (1102)			684 (311)	48.68 (1237)					770 (350)
CHFM25-6195Y-EP	25 x 4 (18.5 x 4)	16.33 (415)	43.35 (1101)	16.81 (427)	□18.66 (□474)	933 (424)	50.20 (1275)	-	-	-	-	1030 (468)
CHFM30-6195Y-EP	30 x 4 (22 x 4)		48.23 (1225)			1046 (475)	55.08 (1399)					1143 (519)
CHFM40-6195Y-EP	40 x 4 (30 x 4)											
CHFM50-6195Y-EP	50 x 4 (37 x 4)											
CHFM60-6195Y-EP	60 x 4 (45 x 4)											

Note: [1] MP Dimension Symbol ϕ = Round Fan Cover
MP Dimension Symbol \square = Square Fan Cover

Dimensions Integral Horizontal F-Flange Mount

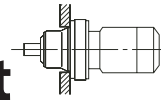

CHFM1-6205DAY-EP ▶ CHFM75-6205Y-EP

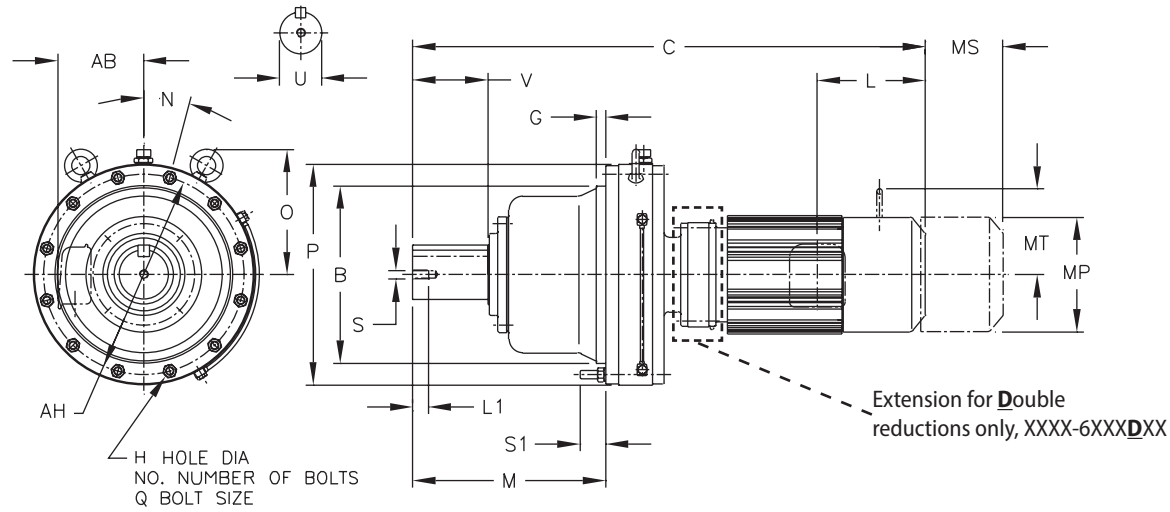

Table 1: Shaft Tolerances All dimensions are in inches (mm)

Low Speed Shaft Nominal Diameter	Tolerance Inches
0.500 through 0.625 (12.700 through 15.875)	+0.0000 / -0.0004 (+0.000 / -0.011)
0.750 through 1.125 (19.050 through 28.757)	+0.0000 / -0.0005 (+0.000 / -0.013)
1.250 through 1.875 (31.750 through 47.625)	+0.0000 / -0.0006 (+0.000 / -0.016)
2.000 through 3.125 (50.800 through 79.375)	+0.0000 / -0.0007 (+0.000 / -0.019)
3.250 through 4.625 (82.550 through 117.475)	+0.0000 / -0.0009 (+0.000 / -0.022)
4.750 through 7.000 (120.650 through 177.800)	+0.0000 / -0.0010 (+0.000 / -0.025)

Note: CHFM units are oil lubricated standard, must be installed as shown above.

Dimensions are in inches (mm)

Model CHFM	B	G	H	NO.	M	N	P	Q	S1	AH
6205Y	14.17 (360)	0.79 (20)	0.71 (18)	12	16.14 (410)	15	17.64 (448)	M16	2.20 (56)	15.94 (405)

All dimensions are in inches (mm)

Model CHFM	Low Speed Shaft				
	U ^[A]	V	S	L1	Key
6205Y	3.88 (98.425)	6.50 (165)	3/4-10UNC	1.34 (34)	1 x 1 x 6.5 (25.4 x 25.4 x 165)

Note: [A] Toleranced dimension, please refer to Table 1 above.

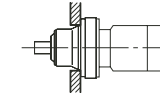

Dimensions Integral Horizontal F-Flange Mount

CHFM1-6205DAY-EP ▶ CHFM75-6205Y-EP

XXXX-6XX0/6XX5 Frame sizes have equal dimensions, different ratings.

All dimensions are in inches (mm), lbs (kg)

Model	HP x P (kW x P)	AB	Without Brake				With Brake					
			C	ML	MP ^[1]	Weight lb (kg)	C	ML	MP ^[1]	MS	MT	Weight lb (kg)
CHFM1-6205DAY-EP	1 x 4 (0.75 x 4)	5.98 (152)	34.57 (878)	3.82 (97)	□6.22 (□158)	510 (231)	37.07 (942)	6.32 (161)	□6.22 (□158)	4.80 (122)	4.25 (108)	519 (236)
CHFM2-6205DAY-EP	2 x 4 (1.5 x 4)	6.16 (156)	35.63 (905)		□6.57 (□167)	520 (236)	38.37 (975)	6.56 (167)	□6.57 (□167)	5.04 (128)	4.61 (117)	531 (241)
CHFM3-6205DAY-EP	3 x 4 (2.2 x 4)	6.71 (170)	35.04 (890)	4.53 (115)	□7.24 (□184)	533 (242)	38.11 (968)	7.60 (193)	□7.24 (□184)	5.43 (138)	5.04 (128)	549 (249)
CHFM3-6205DBY-EP			36.10 (917)									554 (252)
CHFM5-6205DAY-EP	5 x 4 (3.7 x 4)	7.34 (186)	36.50 (927)	4.65 (118)	□8.74 (□222)	558 (253)	40.06 (1018)	8.21 (209)	□8.74 (□222)	6.02 (153)	6.30 (160)	582 (264)
CHFM5-6205DBY-EP			37.36 (949)									579 (263)
CHFM8-6205DAY-EP	7.5 x 4 (5.5 x 4)	7.34 (186)	38.19 (970)	4.65 (118)	□8.74 (□222)	592 (269)	41.75 (1061)	8.21 (209)	□8.74 (□222)	6.02 (153)	6.30 (160)	616 (280)
CHFM8-6205DBY-EP			39.06 (992)									613 (278)
CHFM10-6205DBY-EP	10 x 4 (7.5 x 4)	9.04 (230)	40.55 (1030)	5.43 (138)	□10.24 (□260)	640 (290)	44.69 (1135)	9.57 (243)	□10.24 (□260)	7.44 (189)	7.32 (186)	684 (310)
CHFM15-6205Y-EP	15 x 4 (11 x 4)	9.04 (230)	37.97 (965)									612 (278)
CHFM15-6205DBY-EP			42.99 (1092)	652 (296)	47.13 (1197)	696 (316)						
CHFM20-6205Y-EP	20 x 4 (15 x 4)	10.26 (261)	41.02 (1042)	7.01 (178)	ø12.49 (ø317)	701 (318)	46.32 (1177)	12.30 (313)	ø12.61 (ø320)	9.53 (242)	-	787 (357)
CHFM20-6205DBY-EP			45.43 (1154)									733 (333)
CHFM25-6205Y-EP	25 x 4 (18.5 x 4)	13.39 (340)	44.80 (1138)	9.06 (230)	ø15.12 (ø384)	974 (442)	51.65 (1312)	15.91 (404)	ø15.28 (ø388)	12.13 (308)	-	1071 (486)
CHFM30-6205Y-EP	30 x 4 (22 x 4)		49.69 (1262)									1087 (493)
CHFM40-6205Y-EP	40 x 4 (30 x 4)	16.33 (415)	51.14 (1299)	16.81 (427)	ø18.66 (ø474)	1155 (524)	-	-	-	-	-	-
CHFM50-6205Y-EP	50 x 4 (37 x 4)											
CHFM60-6205Y-EP	60 x 4 (45 x 4)	16.33 (415)	51.14 (1299)	16.81 (427)	ø18.66 (ø474)	1368 (621)	-	-	-	-	-	-
CHFM75-6205Y-EP	75 x 4 (55 x 4)											

Note: [1] MP Dimension Symbol ø = Round Fan Cover
MP Dimension Symbol □ = Square Fan Cover

Dimensions Integral Horizontal F-Flange Mount

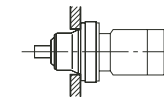

Dimensions Integral Horizontal F-Flange Mount

CHFM2-6215DAY-EP ▶ CHFM75-6215Y-EP

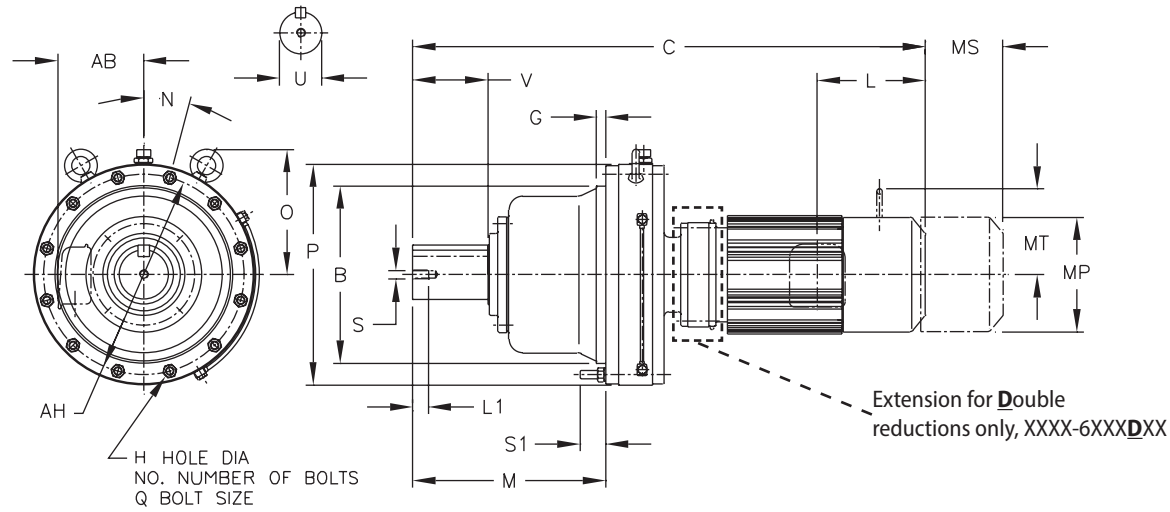

Table 1: Shaft Tolerances All dimensions are in inches (mm)

Low Speed Shaft Nominal Diameter	Tolerance Inches
0.500 through 0.625 (12.700 through 15.875)	+0.0000 / -0.0004 (+0.000 / -0.011)
0.750 through 1.125 (19.050 through 28.757)	+0.0000 / -0.0005 (+0.000 / -0.013)
1.250 through 1.875 (31.750 through 47.625)	+0.0000 / -0.0006 (+0.000 / -0.016)
2.000 through 3.125 (50.800 through 79.375)	+0.0000 / -0.0007 (+0.000 / -0.019)
3.250 through 4.625 (82.550 through 117.475)	+0.0000 / -0.0009 (+0.000 / -0.022)
4.750 through 7.000 (120.650 through 177.800)	+0.0000 / -0.0010 (+0.000 / -0.025)

Note: CHFM units are oil lubricated standard, must be installed as shown above.

Dimensions are in inches (mm)

Model CHFM	B	G	H	NO.	M	N	P	Q	S1	AH
6215Y	15.35 (390)	0.79 (20)	0.81 (20.5)	12	16.65 (423)	15	19.09 (485)	M18	2.20 (56)	17.32 (440)

All dimensions are in inches (mm)

Model CHFM	Low Speed Shaft				
	U ^[A]	V	S	L1	Key
6215Y	4.25 (107.95)	6.50 (165)	3/4-10UNC	1.34 (34)	1 x 1 x 6.5 (25.4 x 25.4 x 165)

Note: [A] Toleranced dimension, please refer to Table 1 above.

CHFM2-6215DAY-EP ▶ CHFM75-6215Y-EP

XXXX-6XX0/6XX5 Frame sizes have equal dimensions, different ratings.

All dimensions are in inches (mm), lbs (kg)

Model	HP x P (kW x P)	AB	Without Brake				With Brake					
			C	ML	MP ^[1]	Weight lb (kg)	C	ML	MP ^[1]	MS	MT	Weight lb (kg)
CHFM2-6215DAY-EP	2 x 4 (1.5 x 4)	6.16 (156)	37.72 (958)	3.82 (97)	□6.57 (□167)	717 (326)	40.45 (1028)	6.56 (167)	□6.57 (□167)	5.04 (128)	4.61 (117)	729 (331)
CHFM3-6215DAY-EP	3 x 4 (2.2 x 4)	6.71 (170)	37.13 (943)	4.53 (115)	□7.24 (□184)	729 (331)	40.20 (1021)	7.60 (193)	□7.24 (□184)	5.43 (138)	5.04 (128)	745 (338)
CHFM5-6215DAY-EP	5 x 4 (3.7 x 4)	7.34 (186)	38.39 (975)	4.65 (118)	□8.74 (□222)	753 (342)	41.95 (1066)	8.21 (209)	□8.74 (□222)	6.02 (153)	6.30 (160)	777 (353)
CHFM5-6215DBY-EP	39.57 (1005)		795 (361)			43.13 (1096)	818 (371)					
CHFM8-6215DAY-EP	40.08 (1018)		787 (357)			43.64 (1109)	811 (368)					
CHFM8-6215DBY-EP	41.26 (1048)	828 (376)	44.82 (1139)	852 (387)								
CHFM10-6215DAY-EP	10 x 4 (7.5 x 4)	9.04 (230)	41.57 (1056)	5.43 (138)	□10.24 (□260)	814 (369)	45.71 (1161)	9.57 (243)	□10.24 (□260)	7.44 (189)	7.32 (186)	858 (389)
CHFM10-6215DBY-EP	42.72 (1085)		856 (389)			46.85 (1190)	901 (409)					
CHFM15-6215Y-EP	39.29 (998)		798 (362)			43.43 (1103)	842 (382)					
CHFM15-6215DAY-EP	15 x 4 (11 x 4)	10.26 (261)	44.02 (1118)	7.01 (178)	ø12.49 (ø317)	826 (375)	48.15 (1223)	12.30 (313)	ø12.61 (ø320)	9.53 (242)		871 (395)
CHFM15-6215DBY-EP	45.16 (1147)		869 (394)			49.29 (1252)	913 (414)					
CHFM20-6215Y-EP	41.97 (1066)		882 (400)			47.26 (1201)	968 (439)					
CHFM20-6215DAY-EP	20 x 4 (15 x 4)	13.39 (340)	46.46 (1180)	9.06 (230)	ø15.12 (ø384)	907 (412)	51.75 (1315)	15.91 (404)	ø15.28 (ø388)	12.13 (308)		993 (451)
CHFM20-6215DBY-EP	47.44 (1205)		952 (432)			52.74 (1340)	1038 (471)					
CHFM25-6215Y-EP	25 x 4 (18.5 x 4)		45.75 (1162)			1150 (522)	52.60 (1336)					1247 (566)
CHFM25-6215DBY-EP	51.61 (1311)	1230 (558)	58.46 (1485)	1327 (602)								
CHFM30-6215Y-EP	30 x 4 (22 x 4)	16.33 (415)	45.75 (1162)	16.81 (427)	ø18.66 (ø474)	1150 (522)	52.60 (1336)					1247 (566)
CHFM30-6215DBY-EP	51.61 (1311)		1230 (558)			58.46 (1485)	1327 (602)					
CHFM40-6215Y-EP	40 x 4 (30 x 4)		50.63 (1286)			1263 (573)	57.48 (1460)					1360 (617)
CHFM50-6215Y-EP	50 x 4 (37 x 4)	16.33 (415)	52.09 (1323)	16.81 (427)	ø18.66 (ø474)	1331 (604)	-	-	-	-	-	-
CHFM60-6215Y-EP	60 x 4 (45 x 4)					1459 (662)	-	-	-	-		
CHFM75-6215Y-EP	75 x 4 (55 x 4)					1539 (698)	-	-	-	-		

Note: [1] MP Dimension Symbol ø = Round Fan Cover
MP Dimension Symbol □ = Square Fan Cover

Dimensions Integral Horizontal F-Flange Mount

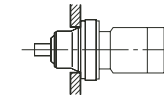

Dimensions Integral Horizontal F-Flange Mount

CHFM2-6225DAY-EP ▶ CHFM50-6235DBY-EP

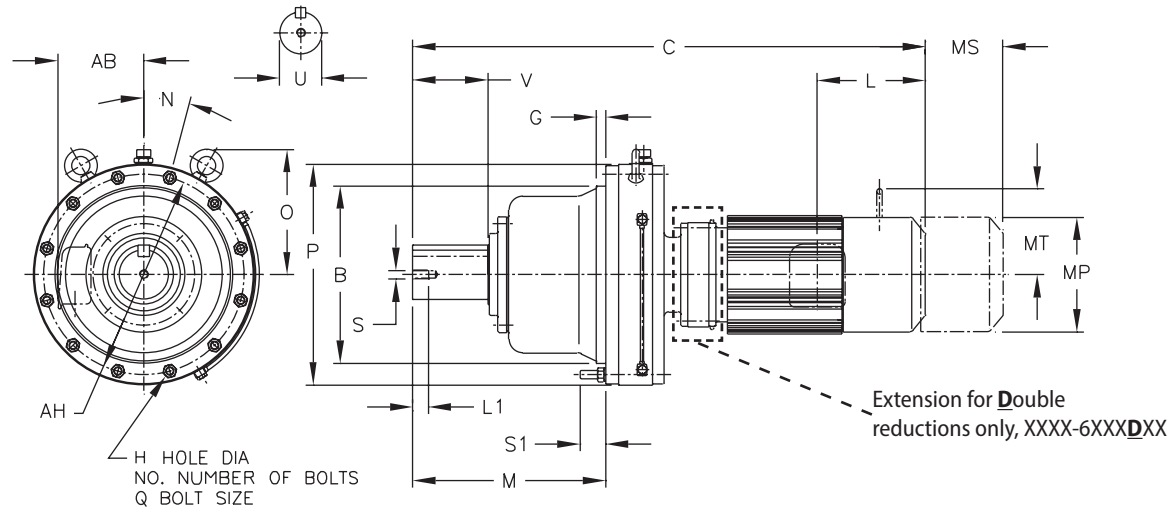

Table 1: Shaft Tolerances All dimensions are in inches (mm)

Low Speed Shaft Nominal Diameter	Tolerance Inches
0.500 through 0.625 (12.700 through 15.875)	+0.0000 / -0.0004 (+0.000 / -0.011)
0.750 through 1.125 (19.050 through 28.757)	+0.0000 / -0.0005 (+0.000 / -0.013)
1.250 through 1.875 (31.750 through 47.625)	+0.0000 / -0.0006 (+0.000 / -0.016)
2.000 through 3.125 (50.800 through 79.375)	+0.0000 / -0.0007 (+0.000 / -0.019)
3.250 through 4.625 (82.550 through 117.475)	+0.0000 / -0.0009 (+0.000 / -0.022)
4.750 through 7.000 (120.650 through 177.800)	+0.0000 / -0.0010 (+0.000 / -0.025)

Note: CHFM units are oil lubricated standard, must be installed as shown above.

Dimensions are in inches (mm)

Model CHFM	B	G	H	NO.	M	N	P	Q	S1	AH
6225Y	16.54 (420)	0.79 (20)	0.87 (22)	12	17.87 (454)	15	20.71 (526)	M20	2.52 (64)	18.70 (475)
6235Y	17.91 (455)	0.79 (20)	0.87 (22)	12	19.92 (506)	15	22.13 (562)	M20	2.56 (65)	20.08 (510)

All dimensions are in inches (mm)

Model CHFM	Low Speed Shaft				
	U ^[A]	V	S	L1	Key
6225Y	4.63 (117.475)	6.50 (165)	3/4-10UNC	1.34 (34)	1-1/4 x 7/8 x 6.5 (31.75 x 22.225 x 165)
6235Y	5.00 (127)	7.87 (200)	1-8UNC	1.61 (41)	1-1/4 x 7/8 x 7.87 (31.75 x 22.225 x 200)

Note: [A] Toleranced dimension, please refer to Table 1 above.

XXXX-6XX0/6XX5 Frame sizes have equal dimensions, different ratings.

All dimensions are in inches (mm), lbs (kg)

CHFM2-6225DAY-EP ▶ CHFM50-6235DBY-EP

Model	HP x P (kW x P)	AB	Without Brake				With Brake					
			C	ML	MP ^[1]	Weight lb (kg)	C	ML	MP ^[1]	MS	MT	Weight lb (kg)
CHFM2-6225DAY-EP	2 x 4 (1.5 x 4)	6.16 (156)	39.37 (1000)	3.82 (97)	□6.57 (□167)	830 (377)	42.11 (1070)	6.56 (167)	□6.57 (□167)	5.04 (128)	4.61 (117)	841 (382)
CHFM3-6225DAY-EP	3 x 4 (2.2 x 4)	6.71 (170)	38.78 (985)	4.53 (115)	□7.24 (□184)	841 (382)	41.85 (1063)	7.60 (193)	□7.24 (□184)	5.43 (138)	5.04 (128)	858 (389)
CHFM5-6225DAY-EP	5 x 4 (3.7 x 4)	7.34 (186)	40.04 (1017)	4.65 (118)	□8.74 (□222)	865 (393)	43.60 (1108)	8.21 (209)	□8.74 (□222)	6.02 (153)	6.30 (160)	889 (404)
CHFM5-6225DBY-EP	42.13 (1070)		966 (438)			45.69 (1161)	990 (449)					
CHFM8-6225DAY-EP	7.5 x 4 (5.5 x 4)	9.04 (230)	41.73 (1060)	5.43 (138)	□10.24 (□260)	899 (408)	45.30 (1151)	9.57 (243)	□10.24 (□260)	7.44 (189)	7.32 (186)	923 (419)
CHFM8-6225DBY-EP	43.82 (1113)		1000 (454)			47.38 (1204)	1024 (465)					
CHFM10-6225DAY-EP	10 x 4 (7.5 x 4)	10.26 (261)	43.23 (1098)	7.01 (178)	ø12.49 (ø317)	926 (420)	47.36 (1203)	12.30 (313)	ø12.61 (ø320)	9.53 (242)		970 (440)
CHFM10-6225DBY-EP	44.65 (1134)		1029 (467)			48.78 (1239)	1073 (487)					
CHFM15-6225DAY-EP	15 x 4 (11 x 4)	13.39 (340)	45.67 (1160)	9.06 (230)	ø15.12 (ø384)	939 (426)	49.80 (1265)	15.91 (404)	ø15.28 (ø388)	12.13 (308)		983 (446)
CHFM15-6225DBY-EP	47.09 (1196)		1041 (473)			51.22 (1301)	1086 (493)					
CHFM20-6225DAY-EP	20 x 4 (15 x 4)	16.33 (415)	48.11 (1222)	16.81 (427)	ø18.66 (ø474)	1019 (463)	53.41 (1357)	-	-	-	-	1105 (502)
CHFM20-6225DBY-EP	49.80 (1265)		1122 (509)			55.10 (1400)	1208 (548)					
CHFM25-6225Y-EP	25 x 4 (18.5 x 4)	16.33 (415)	47.32 (1202)	16.81 (427)	ø18.66 (ø474)	1289 (585)	54.17 (1376)	-	-	-	-	1386 (629)
CHFM25-6225DBY-EP	53.98 (1371)		1401 (636)			60.83 (1545)	1498 (680)					
CHFM30-6225Y-EP	30 x 4 (22 x 4)	16.33 (415)	47.32 (1202)	16.81 (427)	ø18.66 (ø474)	1289 (585)	54.17 (1376)	-	-	-	-	1386 (629)
CHFM30-6225DBY-EP	53.98 (1371)		1401 (636)			60.83 (1545)	1498 (680)					
CHFM40-6225Y-EP	40 x 4 (30 x 4)	16.33 (415)	52.20 (1326)	16.81 (427)	ø18.66 (ø474)	1402 (636)	59.06 (1500)	-	-	-	-	1499 (680)
CHFM40-6225DBY-EP	58.86 (1495)		1514 (687)			65.71 (1669)	1611 (731)					
CHFM50-6225Y-EP	50 x 4 (37 x 4)	16.33 (415)	52.20 (1326)	16.81 (427)	ø18.66 (ø474)	1470 (667)	-	-	-	-	-	-
CHFM60-6225Y-EP	60 x 4 (45 x 4)		1595 (724)			-	-					
CHFM75-6225Y-EP	75 x 4 (55 x 4)	1675 (760)	-	-	-	-						
CHFM3-6235DAY-EP	3 x 4 (2.2 x 4)	6.71 (170)	42.17 (1071)	4.53 (115)	□7.24 (□184)	1078 (489)	45.24 (1149)	7.60 (193)	□7.24 (□184)	5.43 (138)	5.04 (128)	1095 (497)
CHFM5-6235DAY-EP	5 x 4 (3.7 x 4)	7.34 (186)	43.62 (1108)	4.65 (118)	□8.74 (□222)	1103 (501)	47.19 (1199)	8.21 (209)	□8.74 (□222)	6.02 (153)	6.30 (160)	1127 (511)
CHFM8-6235DAY-EP	7.5 x 4 (5.5 x 4)		45.31 (1151)			1137 (516)	48.88 (1242)					1161 (527)
CHFM10-6235DAY-EP	10 x 4 (7.5 x 4)	9.04 (230)	46.77 (1188)	5.43 (138)	□10.24 (□260)	1165 (529)	50.91 (1293)	9.57 (243)	□10.24 (□260)	7.44 (189)	7.32 (186)	1209 (549)
CHFM15-6235DAY-EP	15 x 4 (11 x 4)		49.21 (1250)			53.35 (1355)	1222 (554)					
CHFM15-6235DBY-EP	49.76 (1264)	1251 (568)	53.90 (1369)	1295 (588)								
CHFM20-6235DAY-EP	20 x 4 (15 x 4)	10.26 (261)	51.50 (1308)	7.01 (178)	ø12.49 (ø317)	1261 (572)	56.79 (1443)	12.30 (313)	ø12.61 (ø320)	9.53 (242)		1347 (611)
CHFM20-6235DBY-EP	52.36 (1330)		1331 (604)			57.66 (1465)	1417 (643)					
CHFM25-6235DAY-EP	25 x 4 (18.5 x 4)	13.39 (340)	55.67 (1414)	9.06 (230)	ø15.12 (ø384)	1539 (698)	62.52 (1588)	15.91 (404)	ø15.28 (ø388)	12.13 (308)		1636 (742)
CHFM25-6235DBY-EP	56.54 (1436)		1608 (730)			63.39 (1610)	1705 (774)					
CHFM30-6235DAY-EP	30 x 4 (22 x 4)	13.39 (340)	55.67 (1414)	9.06 (230)	ø15.12 (ø384)	1539 (698)	62.52 (1588)	15.91 (404)	ø15.28 (ø388)	12.13 (308)		1636 (742)
CHFM30-6235DBY-EP	56.54 (1436)		1608 (730)			63.39 (1610)	1705 (774)					
CHFM40-6235DBY-EP	40 x 4 (30 x 4)	16.33 (415)	61.42 (1560)	16.81 (427)	ø18.66 (ø474)	1721 (781)	68.27 (1734)	-	-	-	-	1818 (825)
CHFM50-6235DBY-EP	50 x 4 (37 x 4)		1789 (812)			-	-					

Note: [1] MP Dimension Symbol ø = Round Fan Cover
MP Dimension Symbol □ = Square Fan Cover

Dimensions Integral Horizontal F-Flange Mount

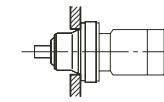

Dimensions Integral Horizontal F-Flange Mount

CHFM3-6245DAY-EP ▶ CHFM60-6255DBY-EP

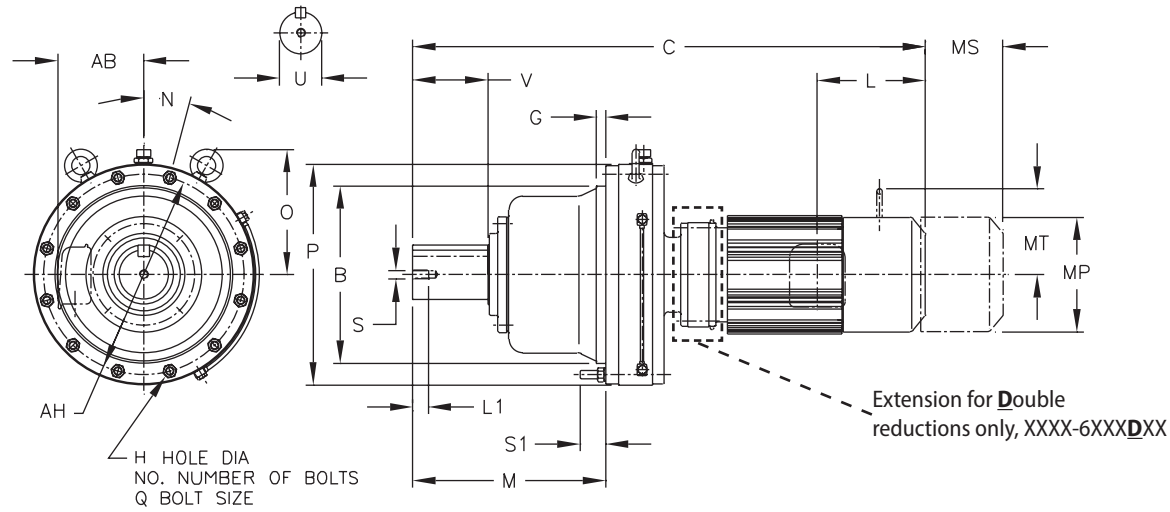

Table 1: Shaft Tolerances All dimensions are in inches (mm)

Low Speed Shaft Nominal Diameter	Tolerance Inches
0.500 through 0.625 (12.700 through 15.875)	+0.0000 / -0.0004 (+0.000 / -0.011)
0.750 through 1.125 (19.050 through 28.757)	+0.0000 / -0.0005 (+0.000 / -0.013)
1.250 through 1.875 (31.750 through 47.625)	+0.0000 / -0.0006 (+0.000 / -0.016)
2.000 through 3.125 (50.800 through 79.375)	+0.0000 / -0.0007 (+0.000 / -0.019)
3.250 through 4.625 (82.550 through 117.475)	+0.0000 / -0.0009 (+0.000 / -0.022)
4.750 through 7.000 (120.650 through 177.800)	+0.0000 / -0.0010 (+0.000 / -0.025)

Note: CHFM units are oil lubricated standard, must be installed as shown above.

Dimensions are in inches (mm)

Model CHFM	B	G	H	NO.	M	N	P	Q	S1	AH
6245Y	19.69 (500)	0.98 (25)	1.06 (27)	12	20.83 (529)	15	24.17 (614)	M24	2.56 (65)	22.05 (560)
6255Y	21.26 (540)	1.18 (30)	1.06 (27)	12	24.25 (616)	15	26.38 (670)	M24	3.58 (91)	24.02 (610)

All dimensions are in inches (mm)

Model CHFM	Low Speed Shaft				
	U ^[A]	V	S	L1	Key
6245Y	5.50 (139.7)	7.87 (200)	1-8UNC	1.61 (41)	1-1/4 x 7/8 x 7.87 (31.75 x 22.225 x 200)
6255Y	6.25 (158.75)	9.45 (240)	1-1/4-7UNC	2.05 (52)	1-1/2 x 1 x 9.45 (38.1 x 25.4 x 240)

Note: [A] Toleranced dimension, please refer to Table 1 above.

XXXX-6XX0/6XX5 Frame sizes have equal dimensions, different ratings.

All dimensions are in inches (mm), lbs (kg)

CHFM3-6245DAY-EP ▶ CHFM60-6255DBY-EP

Model	HP x P (kW x P)	AB	Without Brake				With Brake					
			C	ML	MP ^[1]	Weight lb (kg)	C	ML	MP ^[1]	MS	MT	Weight lb (kg)
CHFM3-6245DAY-EP	3 x 4 (2.2 x 4)	6.71 (170)	43.66 (1109)	4.53 (115)	□7.24 (□184)	1312 (595)	46.73 (1187)	7.60 (193)	□7.24 (□184)	5.43 (138)	5.04 (128)	1329 (603)
CHFM5-6245DAY-EP	5 x 4 (3.7 x 4)	7.34 (186)	45.12 (1146)	4.65 (118)	□8.74 (□222)	1337 (607)	48.68 (1237)	8.21 (209)	□8.74 (□222)	6.02 (153)	6.30 (160)	1361 (617)
CHFM8-6245DAY-EP	7.5 x 4 (5.5 x 4)		46.81 (1189)			1371 (622)						1395 (633)
CHFM10-6245DAY-EP	10 x 4 (7.5 x 4)	9.04 (230)	48.27 (1226)	5.43 (138)	□10.24 (□260)	1399 (635)	52.40 (1331)	9.57 (243)	□10.24 (□260)	7.44 (189)	7.32 (186)	1443 (655)
CHFM15-6245DAY-EP	15 x 4 (11 x 4)		50.71 (1288)			1411 (640)						1455 (660)
CHFM15-6245DBY-EP	15 x 4 (11 x 4)		51.22 (1301)			1478 (671)						1523 (691)
CHFM20-6245DAY-EP	20 x 4 (15 x 4)	10.26 (261)	52.99 (1346)	7.01 (178)	ø12.49 (ø317)	1494 (678)	58.29 (1481)	12.30 (313)	ø12.61 (ø320)	9.53 (242)		1580 (717)
CHFM20-6245DBY-EP	20 x 4 (15 x 4)		53.82 (1367)			1558 (707)						1644 (746)
CHFM25-6245DAY-EP	25 x 4 (18.5 x 4)	13.39 (340)	57.17 (1452)	9.06 (230)	ø15.12 (ø384)	1772 (804)	64.02 (1626)	15.91 (404)	ø15.28 (ø388)	12.13 (308)		1869 (848)
CHFM25-6245DBY-EP	25 x 4 (18.5 x 4)		57.99 (1473)			1835 (833)						1932 (877)
CHFM30-6245DAY-EP	30 x 4 (22 x 4)		57.17 (1452)			1772 (804)						1869 (848)
CHFM30-6245DBY-EP	30 x 4 (22 x 4)		57.99 (1473)			1835 (833)						1932 (877)
CHFM40-6245DBY-EP	40 x 4 (30 x 4)		62.87 (1597)			1948 (884)						2045 (928)
CHFM50-6245DBY-EP	50 x 4 (37 x 4)					2017 (915)						-

CHFM5-6255DAY-EP	5 x 4 (3.7 x 4)	7.34 (186)	50.83 (1291)	4.65 (118)	□8.74 (□222)	1942 (881)	54.39 (1382)	8.21 (209)	□8.74 (□222)	6.02 (153)	6.30 (160)	1966 (892)
CHFM8-6255DAY-EP	7.5 x 4 (5.5 x 4)		52.52 (1334)			1976 (897)						2000 (908)
CHFM10-6255DAY-EP	10 x 4 (7.5 x 4)	9.04 (230)	53.35 (1355)	5.43 (138)	□10.24 (□260)	2005 (910)	57.48 (1460)	9.57 (243)	□10.24 (□260)	7.44 (189)	7.32 (186)	2050 (930)
CHFM15-6255DAY-EP	15 x 4 (11 x 4)		55.79 (1417)			2018 (916)						2062 (936)
CHFM15-6255DBY-EP	15 x 4 (11 x 4)		56.65 (1439)			2188 (993)						2232 (1013)
CHFM20-6255DAY-EP	20 x 4 (15 x 4)	10.26 (261)	58.50 (1486)	7.01 (178)	ø12.49 (ø317)	2098 (952)	63.80 (1621)	12.30 (313)	ø12.61 (ø320)	9.53 (242)		2184 (991)
CHFM20-6255DBY-EP	20 x 4 (15 x 4)		59.37 (1508)			2266 (1028)						2352 (1067)
CHFM25-6255DAY-EP	25 x 4 (18.5 x 4)	13.39 (340)	62.68 (1592)	9.06 (230)	ø15.12 (ø384)	2378 (1079)	69.53 (1766)	15.91 (404)	ø15.28 (ø388)	12.13 (308)		2475 (1123)
CHFM25-6255DBY-EP	25 x 4 (18.5 x 4)		63.54 (1614)			2545 (1155)						2642 (1199)
CHFM30-6255DAY-EP	30 x 4 (22 x 4)		62.68 (1592)			2378 (1079)						2475 (1123)
CHFM30-6255DBY-EP	30 x 4 (22 x 4)		63.54 (1614)			2545 (1155)						2642 (1199)
CHFM40-6255DAY-EP	40 x 4 (30 x 4)		67.56 (1716)			2491 (1130)						2588 (1174)
CHFM40-6255DBY-EP	40 x 4 (30 x 4)		68.43 (1738)			2658 (1206)						2755 (1250)
CHFM50-6255DBY-EP	50 x 4 (37 x 4)		2726 (1237)	-								
CHFM60-6255DBY-EP	60 x 4 (45 x 4)	16.33 (415)	69.88 (1775)	16.81 (427)	ø18.66 (ø474)	2854 (1295)	-	-	-	-	-	-

Note: [1] MP Dimension Symbol ø = Round Fan Cover
MP Dimension Symbol □ = Square Fan Cover

Dimensions Integral Horizontal F-Flange Mount

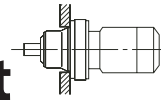

CHFM8-6265DAY-EP ▶ CHFM60-6265DAY-EP

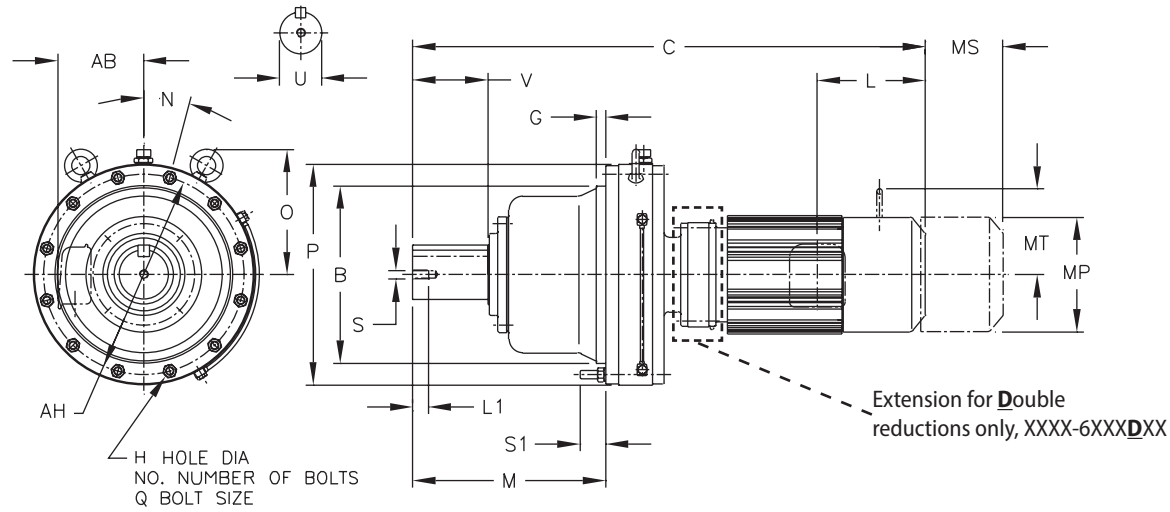

Table 1: Shaft Tolerances All dimensions are in inches (mm)

Low Speed Shaft Nominal Diameter	Tolerance Inches
0.500 through 0.625 (12.700 through 15.875)	+0.0000 / -0.0004 (+0.000 / -0.011)
0.750 through 1.125 (19.050 through 28.757)	+0.0000 / -0.0005 (+0.000 / -0.013)
1.250 through 1.875 (31.750 through 47.625)	+0.0000 / -0.0006 (+0.000 / -0.016)
2.000 through 3.125 (50.800 through 79.375)	+0.0000 / -0.0007 (+0.000 / -0.019)
3.250 through 4.625 (82.550 through 117.475)	+0.0000 / -0.0009 (+0.000 / -0.022)
4.750 through 7.000 (120.650 through 177.800)	+0.0000 / -0.0010 (+0.000 / -0.025)

Note: CHFM units are oil lubricated standard, must be installed as shown above.

Dimensions are in inches (mm)

Model CHFM	B	G	H	NO.	M	N	P	Q	S1	AH
6265Y	22.44 (570)	1.57 (40)	1.34 (34)	12	28.03 (712)	15	28.98 (736)	M30	3.35 (85)	25.98 (660)

All dimensions are in inches (mm)

Model CHFM	Low Speed Shaft				
	U ^[A]	V	S	L1	Key
6265Y	6.63 (168.275)	11.81 (300)	1-1/4-7UNC	2.05 (52)	1-3/4 x 1-1/4 x 11.81 (44.45 x 31.75 x 300)

Note: [A] Toleranced dimension, please refer to Table 1 above.

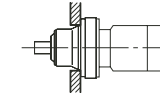

Dimensions Integral Horizontal F-Flange Mount

CHFM8-6265DAY-EP ▶ CHFM60-6265DAY-EP

XXXX-6XX0/6XX5 Frame sizes have equal dimensions, different ratings.

All dimensions are in inches (mm), lbs (kg)

Model	HP x P (kW x P)	AB	Without Brake				With Brake					
			C	ML	MP ^[1]	Weight lb (kg)	C	ML	MP ^[1]	MS	MT	Weight lb (kg)
CHFM8-6265DAY-EP	7.5 x 4 (5.5 x 4)	7.34 (186)	58.31 (1481)	4.65 (118)	□8.74 (□222)	2683 (1217)	61.87 (1572)	8.21 (209)	□8.74 (□222)	6.02 (153)	6.30 (160)	2707 (1228)
CHFM10-6265DAY-EP	10 x 4 (7.5 x 4)	9.04 (230)	58.54 (1487)	5.43 (138)	□10.24 (□260)	2713 (1231)	62.68 (1592)	9.57 (243)	□10.24 (□260)	7.44 (189)	7.32 (186)	2758 (1251)
CHFM15-6265DAY-EP	15 x 4 (11 x 4)		60.98 (1549)			2726 (1237)						65.12 (1654)
CHFM20-6265DAY-EP	20 x 4 (15 x 4)	10.26 (261)	63.70 (1618)	7.01 (178)	∅12.49 (∅317)	2804 (1272)	69.00 (1753)	12.30 (313)	∅12.61 (∅320)	9.53 (242)	-	2890 (1311)
CHFM25-6265DAY-EP	25 x 4 (18.5 x 4)	13.39 (340)	67.87 (1724)	9.06 (230)	∅15.12 (∅384)	3083 (1399)	74.72 (1898)	15.91 (404)	∅15.28 (∅388)	12.13 (308)	-	3180 (1443)
CHFM30-6265DAY-EP	30 x 4 (22 x 4)		72.76 (1848)			3196 (1450)	79.61 (2022)					3293 (1494)
CHFM40-6265DAY-EP	40 x 4 (30 x 4)		72.76 (1848)			3264 (1481)	-					-
CHFM50-6265DAY-EP	50 x 4 (37 x 4)	16.33 (415)	74.21 (1885)	16.81 (427)	∅18.66 (∅474)	3392 (1539)	-	-	-	-	-	-
CHFM60-6265DAY-EP	60 x 4 (45 x 4)					3392 (1539)	-	-	-	-	-	

Note: [1] MP Dimension Symbol ∅ = Round Fan Cover
MP Dimension Symbol □ = Square Fan Cover

This page intentionally left blank.

Gearmotors

Dimensions

3

Options

Options

Integral Vertical F-Flange Mount, Overhead Drive

Double Reduction

CVFM-6130/5DCY ▶ 6180/5DBY

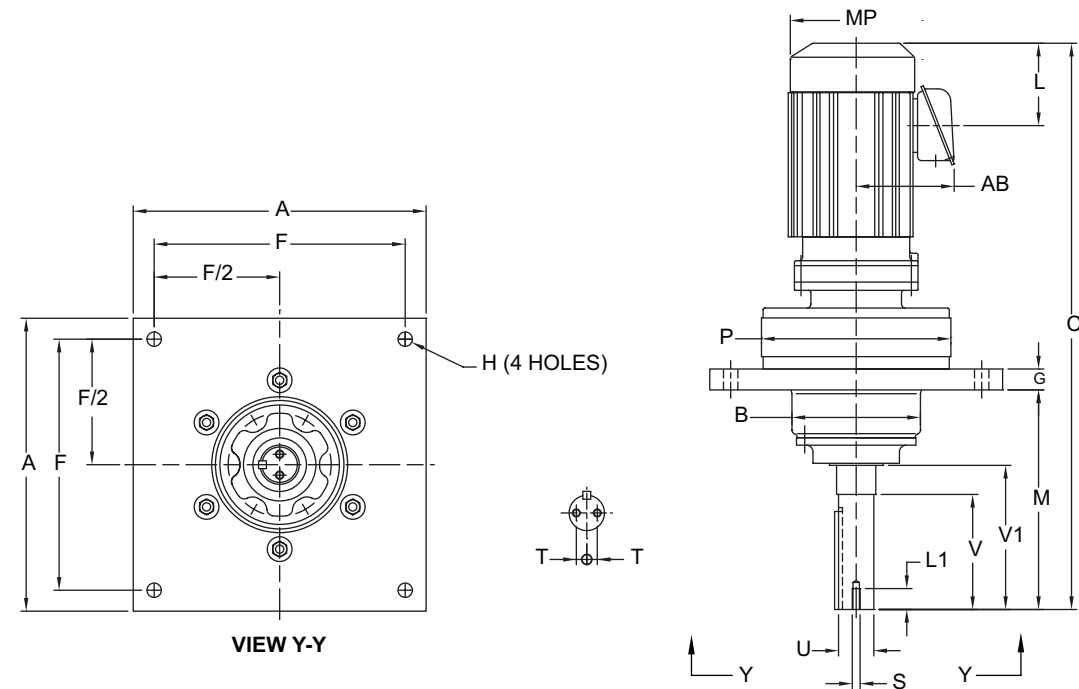

All dimensions are in inches

Model CVFM	Model DVX	A	B	C	F	G	H	M	P
6130/5DCY	35DVX	12.50	6.14	17.91	10.50	0.88	0.56	9.50	9.06
6140/5DBY	40DVX	14.00	6.14	18.80	12.00	1.00	0.43	10.50	9.06
6160/5DCY	50DVX	16.00	7.68	20.15	14.00	1.46	0.81	10.50	11.81
6170/5DCY	60DVX	19.50	8.50	25.82	17.00	1.65	0.94	15.50	13.39
6180/5DBY	70DVX	22.00	9.06	28.00	19.00	1.75	1.12	15.50	14.57

Cyclo® 6000

All dimensions are in inches

Model CVFM	Model DVX	Low Speed Shaft						
		T	U ^[A]	V	V1	S	L1	Key
6130/5DCY	35DVX	0.38	1.6250	4.50	5.76	5/16-18UNC	1.00	3/8 X 3/8 X 3.70
6140/5DBY	40DVX	0.50	1.6875	5.50	6.89	3/8-16UNC	1.00	3/8 X 3/8 X 4.69
6160/5DCY	50DVX	0.75	2.1875	5.50	-	3/8-16UNC	1.00	1/2 X 1/2 X 5.24
6170/5DCY	60DVX	0.75	2.4375	7.50	-	3/8-16UNC	1.00	5/8 X 5/8 X 6.50
6180/5DBY	70DVX	1.00	2.9375	7.50	9.22	3/8-16UNC	1.00	3/4 X 3/4 X 6.50

Note: [A] Toleranced dimension, please refer to Table 1.

Table 1 - Shaft Tolerances

Shaft Nominal Diameter (inches)	Tolerances (inches)
1.250 (1 1/4) through 1.875 (1 7/8)	+0.0000/-0.0006
2.000 (2) through 3.125 (3 1/8)	+0.0000/-0.0007
3.250 (3 1/4) through 4.625 (4 5/8)	+0.0000/-0.0009

Options

Integral Vertical F-Flange Mount, Overhead Drive

Double Reduction

CVFM-6130/5DCY ▶ 6180/5DBY (cont.)

All dimensions are in inches

Model	Motor		Without Brake				Appx Wt (lb)
	HP	Pole	C	AB	L	MP	
CVFM05-6130/5DCY	1/2	4	23.58	5.04	2.32	4.88	138
CVFM08-6130/5DCY	3/4	4	25.19	5.63	3.82	5.83	147
CVFM1-6130/5DCY	1	4	25.19	5.63	3.82	5.83	147
CVFM1H-6130/5DCY	1.5	4	26.49	5.83	3.94	6.30	156
CVFM2-6130/5DCY	2	4	26.49	5.83	3.94	6.30	156
CVFM05-6140/5DBY	1/2	4	24.15	5.04	2.32	4.88	150
CVFM08-6140/5DBY	3/4	4	25.74	5.63	3.82	5.83	158
CVFM1-6140/5DBY	1	4	25.74	5.63	3.82	5.83	158
CVFM1H-6140/5DBY	1.5	4	27.07	5.83	3.94	6.30	167
CVFM2-6140/5DBY	2	4	27.07	5.83	3.94	6.30	167
CVFM05-6160/5DCY	1/2	4	25.03	5.04	2.32	4.88	249
CVFM08-6160/5DCY	3/4	4	26.61	5.63	3.82	5.83	258
CVFM1-6160/5DCY	1	4	26.61	5.63	3.82	5.83	258
CVFM1H-6160/5DCY	1.5	4	27.90	5.83	3.94	6.30	267
CVFM2-6160/5DCY	2	4	27.90	5.83	3.94	6.30	267
CVFM3-6160/5DCY	3	4	28.69	6.10	4.13	6.81	276
CVFM5-6160/5DCY	5	4	29.60	6.54	5.00	8.35	298
CVFM05-6170/5DCY	1/2	4	30.70	5.04	2.32	4.88	404
CVFM08-6170/5DCY	3/4	4	32.28	5.63	3.82	5.83	413
CVFM1-6170/5DCY	1	4	32.28	5.63	3.82	5.83	413
CVFM1H-6170/5DCY	1.5	4	33.58	5.83	3.94	6.30	422
CVFM2-6170/5DCY	2	4	33.58	5.83	3.94	6.30	422
CVFM3-6170/5DCY	3	4	34.36	6.10	4.13	6.81	431
CVFM5-6170/5DCY	5	4	35.27	6.54	5.00	8.35	453
CVFM8-6170/5DCY	7.5	4	37.00	6.54	5.00	8.35	468
CVFM1-6180/5DBY	1	4	34.14	5.63	3.82	5.83	591
CVFM1H-6180/5DBY	1.5	4	35.44	5.83	3.94	6.30	599
CVFM2-6180/5DBY	2	4	35.44	5.83	3.94	6.30	599
CVFM3-6180/5DBY	3	4	36.22	6.10	4.13	6.81	606
CVFM5-6180/5DBY	5	4	37.13	6.54	5.00	8.35	628
CVFM8-6180/5DBY	7.5	4	38.86	6.54	5.00	8.35	643
CVFM10-6180/5DBY	10	4	39.77	8.31	5.63	9.88	677

Cyclo® 6000

Options

Slide Rail

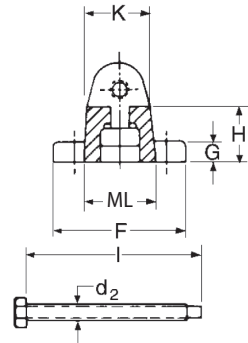
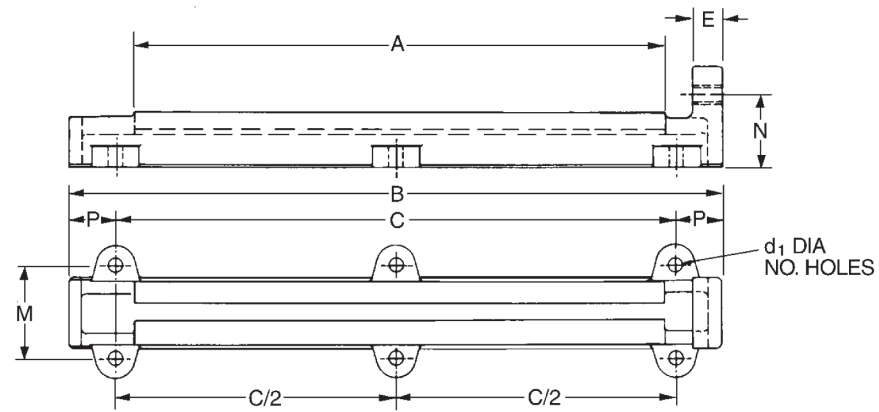

All dimensions are in inches

Model ^[1]	A	B	C	E	F	G	H	K	ML	M	N	P	d ₁	No. Holes	C/2	Wt. Lbs. Pc.	Adjust ^[2] Bolt (d. x i)	Cyclo Mount ^[2] Bolt (Sq.Hd.)
6090, 6095 6100, 6105 610H	10.63	17.32	16.14	.79	1.34	0.71	1.97	1.18	.79	—	2.28	.59	.55	2	—	5	M12 x 4.72	M10 x 1.57
6120, 6125 612H	11.42	20.08	18.50	1.18	1.97	0.98	2.76	1.57	1.18	—	3.15	.79	.71	2	—	10	M16 x 5.12	M12 x 1.97
6130, 6135 6140, 6145 614H	15.75	20.47	16.93	1.18	4.72	0.79	1.97	1.97	2.36	3.35	2.44	1.77	.55	4	—	14	M16 x 6.30	M16 x 2.56
6160, 6165 616H	20.47	25.20	21.65	1.18	5.12	0.98	2.05	2.17	2.76	3.74	2.76	1.77	.55	4	—	26	M16 x 7.87	M16 x 2.56
6170, 6175	21.65	29.53	23.62	1.77	7.09	1.18	2.56	3.15	3.74	5.12	3.35	2.95	.87	4	—	38	M24 x 9.45	M20 x 3.15
6180, 6185	25.59	33.46	27.56	1.77	7.09	1.18	3.15	3.15	3.74	5.12	3.94	2.95	.87	4	—	42	M24 x 11.81	M20 x 3.15
6190, 6195	25.59	33.46	27.56	1.77	9.06	1.57	3.54	3.94	5.12	6.69	4.33	2.95	1.02	4	—	84	M24 x 11.81	M24 x 3.94
6205	31.50	39.37	33.46	1.77	9.06	1.38	3.94	4.72	5.91	7.09	4.92	2.95	1.02	6	16.73	114	M24 x 12.99	M24 x 4.33
6215	31.50	39.37	33.46	1.77	9.06	1.38	3.94	4.72	5.91	7.09	4.92	2.95	1.02	6	16.73	114	M24 x 12.99	M24 x 4.53
6225, 6235	32.28	48.82	37.00	2.17	10.04	1.61	5.51	6.69	10.04	6.89	6.50	5.91	1.54	6	18.50	254	M36 x 16.34	M30 x 4.72
6245	44.09	60.63	48.82	2.17	10.04	1.61	6.89	6.69	10.04	6.89	7.87	5.91	1.54	6	24.41	346	M36 x 25.20	M36 x 5.31
6255	44.09	60.63	48.82	2.17	10.04	1.61	6.89	6.69	10.04	6.89	7.87	5.91	1.54	6	24.41	346	M36 x 25.20	M36 x 5.51

Notes: [1] Models 6090 through 6255 require two rails
[2] Metric bolts furnished by factory; lengths show in inches

Low Speed Shaft Specifications

Metric DIN Style "G"

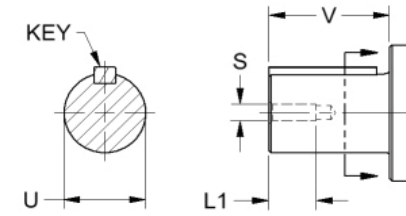

All dimensions are in mm

Size	Type	ØU	Tolerance	V	S	L1	Key Dimensions
606 X	G	14 k6	+0.012 +0.001	25	M5	16	5 x 5 x 20
607 X	G	19 k6	+0.015 +0.002	30	M6	16	6 x 6 x 25
608 X	G	22 k6	+0.015 +0.002	35	M6	16	6 x 6 x 30
609 X	G	28 k6	+0.015 +0.002	35	M8	20	8 x 7 x 32
610 X	G	28 k6	+0.015 +0.002	35	M8	20	8 x 7 x 32
611 X	G	32 k6	+0.018 +0.002	45	M8	20	10 x 8 x 37
612 X	G	38 k6	+0.018 +0.002	55	M8	20	10 x 8 x 50
613 X	G	50 h6	0 -0.016	70	M10	20	14 x 9 x 56
614 X	G	50 h6	0 -0.016	90	M10	20	14 x 9 x 80

X = 0 or 5; single stage and multistage

Metric JIS

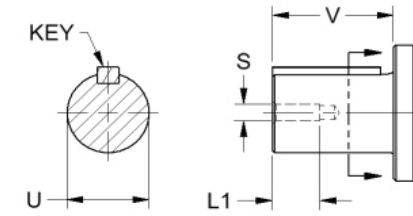

All dimensions are in mm

Size	Type	ØU	Tolerance	V	S	L1	Key Dimensions
606 X	-	14 h6	+0 / -0.011	25	M5	16	5 x 5 x 20
607 X	-	18 h6	+0 / -0.011	30	M6	16	6 x 6 x 25
608 X	-	22 h6	+0 / -0.013	35	M6	16	6 x 6 x 30
609 X	-	28 h6	+0 / -0.013	35	M8	20	8 x 7 x 32
610 X	-	28 h6	+0 / -0.013	35	M8	20	8 x 7 x 32
611 X	-	32 h6	+0 / -0.016	45	M8	20	10 x 8 x 37
612 X	-	38 h6	+0 / -0.016	55	M8	20	10 x 8 x 50
613 X	-	50 h6	+0 / -0.016	70	M10	20	14 x 9 x 56
614 X	-	50 h6	+0 / -0.016	90	M10	20	14 x 9 x 80
616 X	-	60 h6	0 -0.019	90	M10	20	18 x 11 x 80
617 X	-	70 h6	0 -0.019	90	M12	24	20 x 12 x 80
618 X	-	80 h6	0 -0.019	110	M12	24	22 x 14 x 100
619 X	-	95 h6	0 -0.022	135	M20	34	25 x 14 x 125
620 X	-	100 h6	0 -0.022	165	M20	34	28 x 16 x 165
621 X	-	110 h6	0 -0.022	165	M20	34	28 x 16 x 165
622 X	-	120 h6	0 -0.022	165	M20	34	32 x 18 x 165
623 X	-	130 h6	0 -0.025	200	M24	41	32 x 18 x 200
624 X	-	140 h6	0 -0.025	200	M24	41	36 x 20 x 240
625 X	-	160 h6	0 -0.025	240	M30	52	40 x 22 x 240
626 X	-	170 h6	0 -0.025	300	M30	52	40 x 22 x 300
627 X	-	180 h6	0 -0.025	330	M30	52	45 x 22 x 330

X = 0 or 5; single stage and multistage

Metric DIN Style "E"

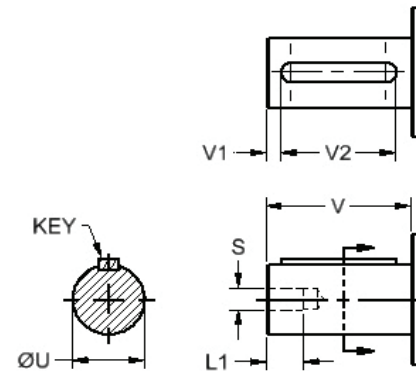

All dimensions are in mm

Size	Type	ØU	Tolerance	V	S	L1	Key Dimensions	V ₁	V ₂
606 X	E	14 k6	+0.012 +0.001	30	M5	16	5 x 5 x 20	2.5	25
607 X	E	20 k6	+0.015 +0.002	40	M6	16	6 x 6 x 25	4	32
608 X	E	25 k6	+0.015 +0.002	50	M10	20	6 x 6 x 30	3.5	40
609 X	E	25 k6	+0.015 +0.002	50	M10	20	8 x 7 x 32	3.5	40
610 X	E	30 k6	+0.015 +0.002	60	M10	20	8 x 7 x 32	3.5	50
611 X	E	35 k6	+0.018 +0.002	70	M12	20	10 x 8 x 37	7	56
612 X	E	35 k6	+0.018 +0.002	70	M12	24	10 x 8 x 50	7	56
613 X	E	50 k6	+0.018 +0.002	100	M16	30	14 x 9 x 56	10	80
614 X	E	50 k6	+0.018 +0.002	100	M16	30	14 x 9 x 80	10	80

X = 0 or 5; single stage and multistage

Options

Industry Packages

Four food-grade packages are available for use in machinery where there is incidental food contact. (Chemi SHIELD, SHIELD360, Food-Grade, and Ultra SHIELD360)

The food-grade optional packages are available for Cyclo® frame sizes 6060 through 6165.

When ordering, choose the Special Specification Code (SSC) that meets your requirements to obtain the features listed below.

Modification	Chemi SHIELD360*	Chemical Duty	Mill Duty	Low Temp	High Temp	Weather Proof IP54	Washdown IP55	SHIELD360*	Food-Grade	Ultra SHIELD360*
Motor Portion										
Gasketed Conduit Box	X	X				X	X	X	X	
V Ring Seal- Fan End	X	X				X	X	X	X	
Special Oil Seal				X	X					
Special Windings				X	X					
Sealer @ Joints	X	X				X	X	X	X	
Stainless Steel or Zinc Hardware	X	X								
Special Fan				X	X					
Epoxy Paint		X	X				X			
FDA Epoxy Paint									X	
FDA White Acrylic Top Coat								X		
FDA Stainless Grey Acrylic Top Coat	X									
Brake Cover and Seal	X	X				X	X	X		
Reducer Portion										
Severe Duty Breather	X	X	X			X	X			X
Epoxy Paint		X	X				X			
FDA Epoxy Paint									X	
FDA White Acrylic Top Coat								X		
FDA Stainless Grey Acrylic Top Coat	X	X								
FDA Stainless Grey Epoxy Clear Top										X
FDA Grease/Oil								X	X	X
Low Temp Grease / Oil				X						
High Temp Grease / Oil					X					
Double Output Seals			X				X			
Polyacrylate High Temp Seals					X					
Low Temperature Seals				X						
FKM AM & Chemical	X	X								X
Stainless Steel or Zinc Hardware										X
Stainless or Tesa Nameplate	X	X								X
Stainless Steel Output Shaft	X									X
High Capacity Bearing			X							
Shoulder Bolts or Dowel Pins			X							
Modified Oil Gauge					X					
Ductile Iron Housing			X							

Cyclo® 6000

Stainless Steel Solid Shaft - maximum torque ratings with standard solid shaft diameters are the same as those listed in this catalog for standard models. Consult the factory when ordering smaller than standard diameters, or if there will be overhung load.

* UltraShield360™ available in quill input option only

Low Temp Package = -30 degrees C Maximum. For lower temperature requirements consult factory.

High Temp Package = 50 degrees C Maximum. For higher temperature requirements consult factory.

4

Technical Information

Overhung Loads • Slow Speed Shaft

Overhung Loads are loads that act perpendicular to the reducer shaft. Each reducer has a maximum allowable overhung load (OHL) capacity, which is shown in the Frame Size Selection Tables for each reducer. In applications with an OHL, it is critical that the OHL is calculated and that the chosen reducer is adequately sized for the maximum OHL.

How to Calculate Overhung Load (OHL)

Step 1. Measure distance X from reducer collar surface to the centerline of the OHL.

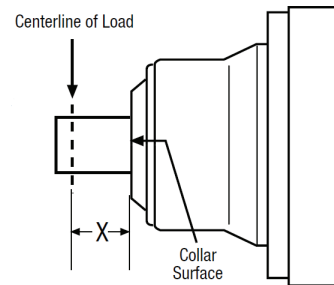

Step 2. Determine Lf (Load Location Factor) for your chosen Frame Size, using Load Location Factor Table on the next page.

Step 3. Determine Cf (Connection Factor) and Fs (Shock Factor) from the tables below:

Connection Factor (Cf)		Shock Factor (Fs)	
CONNECTION TYPE	Cf	SHOCK FACTOR	Fs
General Purpose Chain	Single Row	No Shock	1.0
	Double Row	Moderate Shock	1.3
Machined Gear or Pinion	1.25	Heavy Shock	1.6
Synchronous Belt	1.5		
V-Belt	1.5		
Flat Belt	2.5		

Step 4. Apply Lf, Cf and Sf to the formula to calculate the OHL.

$$Pr = \frac{TI}{R} \leq \frac{Pro}{Lf \cdot Cf \cdot Fs} \quad (\text{lbs, N})$$

- Pr = Actual radial load
- TI = Actual transmitted torque on slow speed shaft of reducer (lb • in, N • m)
- R = Pitch circle radius of sprocket, gear, pulley, ect. (inch, meter)
- Pro = Allowable radial load (lbs, N)
- Cf = Connection factor
- Fs = Shock factor
- Lf = Load location factor

Note: When the Slow Speed Shaft is under both Radial and Axial Load, calculate Overhung Load first and proceed with calculations on Axial Loads page 4.6

Step 5. Refer back to the Frame Size Selection Tables (pp. 2.9–2.100) to determine maximum allowable OHL capacity for the selected Frame Size.

If the calculated OHL does not exceed the OHL capacity (from Selection Table), the selected Frame Size is acceptable.



If the calculated OHL exceeds the OHL capacity, there are two standard options that can increase the OHL capacity of a reducer:

- High Capacity Bearings Option–R1
- Ductile Iron Housing & High Capacity Bearings Option–R2

If neither of these options adequately increase the OHL capacity:

1. Choose the next larger Frame Size, or
2. Move the OHL closer to the collar surface, or
3. Decrease the OHL by increasing the pitch diameter of the connecting drive.

Be sure to recalculate and verify the OHL capacity for the new frame size.

Overhung Loads, Slow Speed Shaft continued

Table 4.1 Load Location Factors (Lf), Slow Speed Shaft

Frame Size		X (inches)																			
Single Reduction	Double Reduction	1/4	1/2	3/4	1	1 1/4	1 1/2	1 3/4	2	2 1/2	3	3 1/2	4	4 1/2	5	6	7	8	9	10	11
6060, 6065	6060DA, 6065DA	0.86	1.08	1.49	—	—	—	—	—	—	—	—	—	—	—	—	—	—	—	—	—
6070, 6075	6070DA, 6075DA	0.85	0.96	1.23	1.61	—	—	—	—	—	—	—	—	—	—	—	—	—	—	—	—
6080, 6085	—	0.83	0.91	1.01	1.30	1.63	—	—	—	—	—	—	—	—	—	—	—	—	—	—	—
6090, 6095	6090DA, 6095DA	0.88	0.95	1.10	1.40	1.73	—	—	—	—	—	—	—	—	—	—	—	—	—	—	—
6100 6105 610H	6100DA, 6105DA	0.88	0.95	1.10	1.40	1.73	—	—	—	—	—	—	—	—	—	—	—	—	—	—	—
6110, 6115	—	0.80	0.87	0.95	1.02	1.12	1.30	1.51	—	—	—	—	—	—	—	—	—	—	—	—	—
6120, 6125 612H	6120DA, 6120DB 6125DA, 6125DB	—	0.85	0.91	0.98	1.14	1.36	1.57	—	—	—	—	—	—	—	—	—	—	—	—	—
6130 6135	6130DA, 6130DB 6130DC, 6135DA 6135DB, 6135DC	—	—	0.86	0.92	0.97	1.08	1.24	1.40	1.72	—	—	—	—	—	—	—	—	—	—	—
6140 6145 614H	6140DA, 6140DB 6140DC, 6145DA 6145DB, 6145DC	—	—	—	0.74	0.82	0.91	0.99	1.12	1.37	1.62	1.88	—	—	—	—	—	—	—	—	—
6160 6165 616H	6160DA, 6160DB 6160DC, 6165DA 6165DB, 6165DC	—	—	—	0.87	0.91	0.95	1.00	1.13	1.39	1.67	1.94	—	—	—	—	—	—	—	—	—
6170 6175	6170DA, 6170DB 6170DC, 6175DA	—	—	—	0.89	0.93	0.96	1.00	1.13	1.39	1.67	1.94	—	—	—	—	—	—	—	—	—
6180 6185	6180DA, 6180DB 6185DA, 6185DB	—	—	—	0.85	0.88	0.92	0.95	0.99	1.15	1.37	1.58	—	—	—	—	—	—	—	—	—
6190 6195	6190DA, 6190DB 6195DA, 6195DB	—	—	—	—	0.86	0.88	0.91	0.93	0.99	1.13	1.30	1.48	1.67	—	—	—	—	—	—	—
6205	6205DA, 6205DB	—	—	—	—	—	—	0.74	0.78	0.86	0.95	1.04	1.13	1.22	1.31	1.49	—	—	—	—	—
6215	6215DA, 6215DB	—	—	—	—	—	—	0.73	0.78	0.86	0.95	1.04	1.14	1.23	1.32	1.50	—	—	—	—	—
6225	6225DA, 6225DB	—	—	—	—	—	—	0.88	0.90	0.94	0.98	1.02	1.06	1.10	1.14	1.23	—	—	—	—	—
6235	6235DA, 6235DB	—	—	—	—	—	—	0.84	0.85	0.89	0.93	0.97	1.00	1.04	1.08	1.16	1.23	—	—	—	—
6245	6245DA, 6245DB	—	—	—	—	—	—	0.84	0.86	0.90	0.93	0.97	1.00	1.04	1.08	1.15	1.22	—	—	—	—
6255	6255DA, 6255DB	—	—	—	—	—	—	0.83	0.86	0.89	0.93	0.95	0.99	1.02	1.08	1.21	1.38	1.54	—	—	—
6265	6265DA	—	—	—	—	—	—	—	—	—	0.84	0.88	0.90	0.93	0.95	1.02	1.16	1.31	1.47	1.64	1.80
6275	6275DA	—	—	—	—	—	—	—	—	—	—	0.71	0.76	0.80	0.85	0.95	1.08	1.23	1.37	1.52	1.67

Overhung Loads, Slow Speed Shaft continued

Overhung Loads, Slow Speed Shaft continued

Table 4.2 High Capacity Bearings Option

Type R1

Slow Speed Shaft Overhung Load Capacity (lbs.)

Frame Size		Output Shaft Speed (RPM)							
Single Reduction	Double Reduction	10 & Below	15	20	25	30	35	40	50
6130, 6135, 6140, 6145, 614H	6130DA, 6130DB 6130DC, 6135DA 6135DB, 6135DC, 6140DA, 6140DB, 6140DC, 6145DA, 6145DB, 6145DC	3310	3310	3310	3310	3310	3310	3310	3310
6160 6165 616H	6160DA, 6160DB 6160DC, 6165DA 6165DB, 6165DC	4960	4960	4960	4960	4960	4960	4960	4960
6170 6175	6170DA, 6170DB 6170DC, 6175DA 6175DB, 6175DC	6640	6640	6640	6640	6640	6640	6640	6640
6180 6185	6180DA, 6180DB 6185DA, 6185DB	9370	9370	9370	9370	9370	9370	9370	9370
6190 6195	6190DA, 6190DB 6195DA, 6195DB	13200	13200	13200	13200	13200	13200	13200	12400

Frame Size		Output Shaft Speed (RPM)							
Single Reduction	Double Reduction	60	80	100	125	150	200	250	300
6130, 6135, 6140, 6145, 614H	6130DA, 6130DB 6130DC, 6135DA 6135DB, 6135DC, 6140DA, 6140DB, 6140DC, 6145DA, 6145DB, 6145DC	3310	3170	3040	2820	2670	2450	2290	2170
6160 6165 616H	6160DA, 6160DB 6160DC, 6165DA 6165DB, 6165DC	4960	4960	4850	4520	4280	3920	3660	3460
6170 6175	6170DA, 6170DB 6170DC, 6175DA 6175DB, 6175DC	6640	6640	6590	6150	5820	5360	4980	4740
6180 6185	6180DA, 6180DB 6185DA, 6185DB	9370	9280	8660	8140	7690	7050	—	—
6190 6195	6190DA, 6190DB 6195DA, 6195DB	11900	10600	9900	9220	8600	7800	—	—

Table 4.3 Ductile Iron Housing and High Capacity Bearings Option

Type R2

Slow Speed Shaft Overhung Load Capacity (lbs.)

Frame Size		Output Shaft Speed (RPM)									
Single Reduction	Double Reduction	4 & Below	5	6	8	10	15	20	25	30	35
6130, 6135, 6140, 6145, 614H	6130DA, 6130DB 6130DC, 6135DA 6135DB, 6135DC, 6140DA, 6140DB, 6140DC, 6145DA, 6145DB, 6145DC	5396	5396	5396	5396	5396	5351	4901	4586	4339	4137
6160 6165 616H	6160DA, 6160DB 6160DC, 6165DA 6165DB, 6165DC	7554	7554	7554	7554	7554	7554	7554	7487	7082	6767
6170 6175	6170DA, 6170DB 6170DC, 6175DA 6175DB, 6175DC	10319	10319	10319	10319	10319	10319	10319	10184	9645	9195
6180 6185	6180DA, 6180DB 6185DA, 6185DB	12522	12522	12522	12522	12522	12522	12522	12522	12522	12140
6190 6195	6190DA, 6190DB 6195DA, 6195DB	16142	16142	16142	16142	16142	16142	16142	16142	15580	14861
6205	6205DA, 6205DB	21987	21987	21987	21987	21987	20031	18390	17199	16277	15535
6215	6215DA, 6215DB	29860	28327	26754	24505	22932	20346	18660	17446	16524	15760
6225	6225DA, 6225DB	36196	35072	33273	30351	28327	25180	23156	21650	20479	19559
6235	6235DA, 6235DB	41142	41142	41142	38219	35746	31700	29002	27203	25629	24505
6245	6245DA, 6245DB	50135	46987	44514	40692	37995	33723	31025	29002	27428	26079
6255	6255DA, 6255DB	61601	58004	54856	50360	47212	41592	38219	35746	33948	32374
6265	6265DA	63624	63624	63624	60701	56879	50360	46088	42941	40692	39119
6275	6275DA	61151	61151	61151	61151	61151	61151	61151	61151	61151	—

Frame Size		Output Shaft Speed (RPM)									
Single Reduction	Double Reduction	40	50	60	80	100	125	150	200	250	300
6130, 6135, 6140, 6145, 614H	6130DA, 6130DB 6130DC, 6135DA 6135DB, 6135DC, 6140DA, 6140DB, 6140DC, 6145DA, 6145DB, 6145DC	4002	3710	3507	3237	3035	2833	2675	2451	2293	2172
6160 6165 616H	6160DA, 6160DB 6160DC, 6165DA 6165DB, 6165DC	6497	6070	5755	5283	4946	4609	4362	4024	3732	3462
6170 6175	6170DA, 6170DB 6170DC, 6175DA 6175DB, 6175DC	8835	8273	7824	7172	6722	6272	5935	5463	4991	4744
6180 6185	6180DA, 6180DB 6185DA, 6185DB	11668	10904	10319	9465	8858	8296	7846	7194	—	—
6190 6195	6190DA, 6190DB 6195DA, 6195DB	14276	13354	12657	11601	10859	10139	9622	8835	—	—
6205	6205DA, 6205DB	14928	13961	13219	12140	11353	10589	10027	9218	—	—
6215	6215DA, 6215DB	15153	14164	13399	12320	11533	10769	10207	9353	—	—
6225	6225DA, 6225DB	18772	17558	16637	15265	14276	13354	12657	11578	—	—
6235	6235DA, 6235DB	23606	22055	20886	19177	17941	16749	—	—	—	—
6245	6245DA, 6245DB	25180	23606	22235	20414	19087	17851	—	—	—	—
6255	6255DA, 6255DB	31250	29002	27653	25180	23606	22100	—	—	—	—
6265	6265DA	37320	35072	33273	30351	28327	26529	—	—	—	—
6275	6275DA	—	—	—	—	—	—	—	—	—	—

Indicates ductile iron housing and high capacity bearing is standard

Technical Information

Technical Information

Overhung Loads, Slow Speed Shaft continued

Axial Loads

Table 4.3 Ductile Iron Housing and High Capacity Bearings Option (cont.)

Type R2
V Dimensions (Usable shaft length)

Model	6130/5	6140/5 614H	6160/5 616H	6170/5	6180/5	6190/5
V in (mm)	2.40 (61)	3.19 (81)	3.15 (80)	3.31 (84)	3.94 (100)	4.92 (125)

How to Calculate Axial Loads

When axial and overhung loads are combined to act on the Slow Speed Shaft, this formula is used to determine if the combined loading is acceptable for the selected Cyclo® reducer.

Axial Loads are loads that act parallel to the reducer shaft. Each reducer has a maximum allowable axial load capacity, which is shown in table below. When the maximum allowable axial load exceeds the capacity shown in the table, the next larger frame size should be chosen.

Axial Load, PA

$$P_a \leq \frac{P_{ao}}{C_f \cdot F_s} \quad (\text{lbs, N})$$

Formula for Combined Radial and Axial Load on Slow Speed Shaft

$$\left(\frac{P_r \cdot L_f}{P_{ro}} + \frac{P_a}{P_{ao}} \right) \cdot C_f \cdot F_s \leq 1$$

- Pr = Actual Overhung Load
- Lf = Load Location Factor
- Pro = Allowable Overhung Load
- Pa = Actual Axial Load (lbs, N)
- Pao = Allowable Axial Load (lbs,N)
- Cf = Connection Factor
- Fs = Shock Factor



If the calculated loads exceed the limits shown below in Axial Load Capacity Table:

1. Decrease the OHL by moving the load closer to the shaft collar or by increasing the pitch diameter of the connecting device,
- or
2. Select the next larger frame size. Repeat the Axial Load calculation to verify the selection.

Table 4.4 Axial Load Capacity, Slow Speed Shaft (lbs.)

Frame Size		Output Shaft Speed (RPM)															
Single Reduction	Double Reduction	~10	15	20	25	30	35	40	50	60	80	100	125	150	200	250	300
6060 6065	6060DA 6065DA	66	66	66	66	66	66	66	66	66	66	66	66	66	66	—	—
6070 6075	6070DA 6075DA	176	176	176	176	176	176	176	176	176	176	176	176	176	176	176	176
6080 6085	—	221	221	221	221	221	221	221	221	221	221	221	221	221	221	221	221
6090 6095	6090DA 6095DA	221	221	221	221	221	221	221	221	221	221	221	221	221	221	221	221
6100 6105 610H	6100DA 6105DA	330	330	330	330	330	330	330	330	330	330	330	330	330	330	330	330
6110 6115	—	330	330	330	330	330	330	330	330	330	330	330	330	330	330	330	330
6120 6125 612H	6120DA 6120DB 6125DA 6125DB	661	661	661	661	661	661	661	661	661	661	661	661	661	623	562	537
6130 6135	6130DA 6130DB 6130DC 6135DA 6135DB 6135DC	881	881	881	881	881	881	881	881	881	881	881	881	881	881	881	881
6140 6145 614H	6140DA 6140DB 6140DC 6145DA 6145DB 6145DC	1214	1214	1214	1214	1214	1214	1214	1214	1176	1093	1025	982	866	825	776	—
6160 6165 616H	6160DA 6160DB 6160DC 6165DA 6165DB 6165DC	1545	1545	1545	1545	1545	1545	1545	1545	1545	1545	1545	1545	1545	1416	1281	—
6170 6175	6170DA 6170DB 6170DC 6175DA 6175DB 6175DC	2205	2205	2205	2205	2205	2205	2205	2205	2205	2205	2205	2176	2028	1819	1648	1547
6180 6185	6180DA 6180DB 6185DA 6185DB	3080	3080	3080	3080	3080	3080	3080	3080	3080	3080	3080	2945	2810	2473	—	—
6190 6195	6190DA 6190DB 6195DA 6195DB	4406	4406	4406	4406	4406	4406	4406	4406	4406	4406	4406	4159	3934	3462	—	—
6205	6205DA 6205DB	5958	5283	4744	4406	4182	4069	3979	3754	3530	3192	2968	2878	2765	2540	—	—
6215	6215DA 6215DB	6183	5508	4969	4631	4406	4182	4069	3867	3642	3305	3080	2968	2878	2653	—	—
6225	6225DA 6225DB	6610	5755	5216	4879	4631	4406	4204	3957	3754	3440	3237	3058	2945	2720	—	—
6235	6235DA 6235DB	7936	7059	6385	5958	5621	5283	5081	4744	4519	4182	3979	3754	—	—	—	—
6245	6245DA 6245DB	8386	7599	6947	6475	6138	5868	5643	5283	5013	4721	4474	4294	—	—	—	—
6255	6255DA 6255DB	10814	9690	8858	8296	7891	7554	7262	6835	6407	6025	5733	5441	—	—	—	—
6265	6265DA	11691	11691	11466	10679	10072	9622	9353	8746	8386	7824	7419	6992	—	—	—	—
6275	6275DA	13242	13242	13242	13242	13242	13242	13242	13242	—	—	—	—	—	—	—	—

Technical Information

Technical Information

Overhung Loads • High Speed Shaft

Overhung Loads are loads that act perpendicular to the reducer shaft. Each reducer has a maximum allowable overhung load (OHL) capacity, which is shown in the Frame Size Selection Tables for each reducer. In applications with an OHL, it is critical that the OHL is calculated and that the chosen reducer is adequately sized for the maximum OHL.

How to Calculate Overhung Load (OHL)

Step 1. Measure distance X from reducer collar surface to the centerline of the OHL.

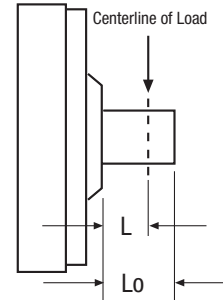

Step 2. Determine Lf (Load Location Factor) for your chosen Frame Size, using Load Location Factor Table on the next page.

Step 3. Determine Cf (Connection Factor) and Fs (Shock Factor) from the tables below:

Connection Factor (Cf)		Shock Factor (Fs)	
CONNECTION TYPE	Cf	SHOCK FACTOR	Fs
General Purpose Chain	Single Row 1.0	No Shock	1.0
	Double Row 1.25	Moderate Shock	1.3
Machined Gear or Pinion	1.25	Heavy Shock	1.6
Synchronous Belt	1.50		
V-Belt	1.50		
Flat Belt	2.50		

Step 4. Apply Lf, Cf and Sf to the formula to calculate the OHL.

$$Pr = \frac{TI}{R} \leq \frac{Pro}{Lf \cdot Cf \cdot Fs} \quad (\text{lbs, N})$$

Pr = Actual radial load
 TI = Actual transmitted torque on slow speed shaft of reducer (lb • in, N • m)
 R = Pitch circle radius of sprocket, gear, pulley, ect. (inch, meter)
 Pro = Allowable radial load (lbs, N)
 Cf = Coupling factor
 Fs = Shock factor
 Lf = Load location factor

Step 5. Refer back to the OHL Capacity Table to determine maximum allowable OHL capacity for the selected Frame Size.

If the calculated OHL does not exceed the OHL capacity (from Selection Table), the selected Frame Size is acceptable.

If the calculated OHL exceeds the OHL capacity, you must choose the next larger Frame Size. Be sure to recalculate and verify the OHL capacity for the new frame size.



Overhung Loads, High Speed Shaft continued

Table 4.5 Load Location Factors (Lf), High Speed Shaft

Frame Size		L (inch)																		
Single Reduction	Double Reduction	1/4	1/2	3/4	1	1 1/4	1 1/2	1 3/4	2	2 1/2	3	3 1/2	4	4 1/2	5	5 1/2	6	6 1/2	7	7 1/2
6060 6065	6060DA 6065DA 6070DA 6075DA	0.78	1.07	1.52	—	—	—	—	—	—	—	—	—	—	—	—	—	—	—	—
6070 6075	6090DA 6095DA 6100DA 6105DA 6120DA 6125DA 6130DA 6135DA 6140DA 6145DA	0.78	1.07	1.52	—	—	—	—	—	—	—	—	—	—	—	—	—	—	—	—
6080 6085	—	0.78	1.07	1.52	—	—	—	—	—	—	—	—	—	—	—	—	—	—	—	—
6090 6095	6120DB 6125DB 6130DB 6135DB 6140DB 6145DB 6160DA 6165DA 6170DA 6175DA	0.90	1.09	1.52	2.03	—	—	—	—	—	—	—	—	—	—	—	—	—	—	—
6100 6105 610H	6130DC 6135DC 6140DC 6145DC 6160DB 6165DB 6170DB 6175DB 6180DA 6185DA	0.93	1.09	1.52	2.03	—	—	—	—	—	—	—	—	—	—	—	—	—	—	—
6110 6115	—	0.93	1.09	1.52	2.03	—	—	—	—	—	—	—	—	—	—	—	—	—	—	—
6120 6125 612H	6160DC 6165DC 6170DC 6175DC 6190DA 6195DA 6205DA	—	0.87	1.10	1.43	1.77	2.12	—	—	—	—	—	—	—	—	—	—	—	—	—
6130 6135	6180DB 6185DB 6190DB 6195DB 6205DB 6215DA 6225DA	—	0.84	0.98	1.25	1.53	1.83	2.11	—	—	—	—	—	—	—	—	—	—	—	—
6140 6145 614H	—	—	0.84	0.98	1.25	1.53	1.83	2.11	—	—	—	—	—	—	—	—	—	—	—	—
6160 6165 616H	6215DB 6235DA 6245DA	—	0.94	0.97	1.06	1.22	1.36	1.51	1.66	—	—	—	—	—	—	—	—	—	—	—
6170 6175	6255DA 6225DB	—	—	0.95	0.99	1.09	1.23	1.38	1.51	1.79	2.08	—	—	—	—	—	—	—	—	—
6180 6185	6235DB 6245DB	—	—	—	0.96	1.01	1.11	1.24	1.37	1.63	1.88	2.15	—	—	—	—	—	—	—	—
6190 6195	6255DB 6265DA 6275DA	—	—	—	0.95	0.99	1.06	1.15	1.26	1.47	1.69	1.90	—	—	—	—	—	—	—	—
6205	—	—	—	—	0.93	0.96	0.99	1.04	1.11	1.26	1.40	1.55	1.70	1.84	—	—	—	—	—	—
6215	—	—	—	—	0.93	0.96	0.99	1.03	1.09	1.23	1.36	1.50	1.63	1.76	—	—	—	—	—	—
6225	—	—	—	—	0.94	0.97	0.99	1.02	1.04	1.10	1.20	1.32	1.43	1.55	—	—	—	—	—	—
6235	—	—	—	—	0.84	0.86	0.88	0.93	0.99	1.10	1.22	1.33	1.45	1.57	—	—	—	—	—	—
6245	—	—	—	—	0.91	0.93	0.95	0.98	1.00	1.10	1.21	1.32	1.43	1.54	—	—	—	—	—	—
6255	—	—	—	—	—	0.93	0.94	0.96	1.00	1.07	1.15	1.23	1.31	1.39	1.47	1.55	1.63	1.71	—	—
6265	—	—	—	—	—	0.93	0.94	0.96	1.00	1.07	1.15	1.23	1.31	1.39	1.47	1.55	1.63	1.71	—	—
6275	—	—	—	—	—	—	—	0.94	0.98	1.02	1.13	1.23	1.34	1.45	1.56	1.66	1.77	1.90	2.00	—

Overhung Loads, High Speed Shaft continued

Table 4.6 Overhung Load Capacity, High Speed Shaft (lbs.)

Frame Size		Ratio	Input Speed (RPM)						
Single Reduction	Double Reduction		1750	1450	1165	980	870	720	580
6060 6065	6060DA 6065DA 6070DA 6075DA	6~17, 25~35 21, 43	44 17.6	33 6.6	33 11	44 11	44 11	44 11	44 11
6070 6075	6090DA 6095DA 6100DA 6105DA 6120DA 6125DA 6130DA 6135DA 6140DA 6145DA	6~17, 25~35, 51, 59 21, 43	44 11	33 11	33 11	44 11	44 11	44 33	44 44
6080 6085	—	6~15, 21, 29, 43~59, 87 17, 35, 71	44 11	33 11	33 11	44 11	44 11	44 33	44 44
6090 6095	6120DB 6125DB 6130DB 6135DB 6140DB 6145D 6160DA 6165DA 6170DA 6175DA	6~17, 25~71, 119 21, 87	66 44	66 44	66 44	66 44	66 55	66 55	66 66
6100 6105 610H	6130DC 6135DC 6140DC 6145DC 6160DB 6165DB 6170DB 6175DB 6180DA 6185DA	6~11, 17~119 13, 15	99 99	99 77	110 99	121 110	132 110	132 121	132 132
6110 6115	—	6, 8, 21~87 11~17	99 44	77 44	99 44	110 44	110 55	121 55	132 66
6120 6125 612H	6160DC 6165DC 6170DC 6175DC 6190DA 6195DA 6205DA	6~17 21~87	133 121	155 99	166 110	175 121	198 133	198 198	198 198
6130 6135	6180DB 6185DB 6190DB 6195DB 6205DB 6215DA 6225DA	6~17, 21 25~87	308 288	308 288	308 288	342 308	364 330	387 353	418 398
6140 6145 614H	—	6, 8 11~21 25 29~87	308 277 243 121	308 220 254 133	308 243 265 133	342 265 288 155	364 277 297 155	387 297 308 155	418 330 330 243
6160 6165 616H	6215DB 6235DA 6245DA	6~25, 51, 59 29~43, 71, 87	398 243	398 265	441 288	463 308	486 308	486 353	486 398
6170 6175	6255DA 6225DB	11~87	463	463	508	508	528	551	596
6180 6185	6235DB 6245DB	11~87	618	573	618	661	683	751	771
6190 6195	6255DB 6265DA 6275DA	11~25 29~87	683 596	683 573	728 638	794 661	816 706	881 751	881 816
6205	—	11~87	1214	1104	1214	1324	1367	1401	1389
6215	—	11~87	1290	1147	1223	1378	1423	1533	1632
6225	—	11~87	1488	1302	1344	1378	1488	1567	1686
6235	—	11~87	—	—	2248	2140	2062	2019	1963
6245	—	11~87	—	—	2496	2271	2271	2383	2518
6255	—	11~87	—	—	2653	2428	2540	2765	2945
6265	—	11~87	—	—	2653	2428	2540	2765	2945
6275	—	29~87	—	—	3305	3305	3305	3305	3305

Lubrication

Cyclo® Gearmotors are either Grease lubricated or Oil lubricated. Refer to pages 4.11 and 4.12 to determine the unit lubrication type.

- Grease lubricated gearmotors are filled with grease prior to shipment and are ready for installation and operation
- Oil lubricated gearmotors must be filled with the proper amount of approved oil before installation and operation
- Lubrication methods (grease or oil) are specified for Cyclo® driven at standard input speed.

NOTE: Some models normally designed for oil lubrication may be specially ordered for grease lubrication; please consult factory.

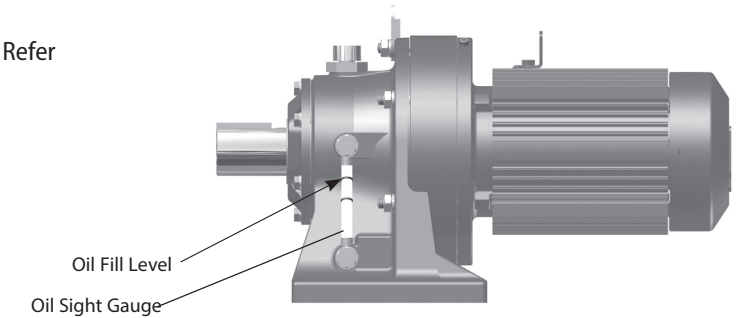

Figure 4.10 Oil Level Gauge

Approved Greases

Grease lubricated gearmotors are filled with grease prior to shipment and are ready for installation and operation. This information is provided for maintenance purposes.

Table 4.7a Approved Greases

Frame Size	Ambient Temperature		Planetary (NLGI Grade 0)	Cycloid Discs (NLGI Grade 2)
	°F	°C		
606X TO 612X	14 to 122	-10 to 50	Shell Gadus S2 V220 (610X, 612X TO 617X)	Mobil Unirex N2
613X TO 616X				Shell Gadus S2 V220
617X TO 626X				

Note: - For double reduction units, standard grease is Mobil Unirex N2 NLGI Grade 2, except for frame sizes 6215DB, 6225DB, 6235DA/DB, 6245DA/DB, 6255DA/DB, 6265DA and 6275DA, which standard grease is Shell Gadus S2 V220 NLGI Grade 2.
- For triple reduction units, standard grease is Mobil Unirex N2 NLGI Grade 2.

Approved Oils

Oil lubricated gearmotors must be filled with oil prior to operation. Fill the gearmotor to the correct level with the recommended oil.

Approved Oils:

Mobil	Spartan EP	Idemitsu	Daphne Super Gear Oil	BP	Energol GR-XP
Mobil	Mobilgear 600XP	Kluber	Kluberoll GEM1	Castrol	Alpha SP
Mobil	Mobil SHC Gear	Chevron	Meropa	Gulf	EP Lubricant HD
Mobil	Hi-Shock			Shell	Omala S2 G

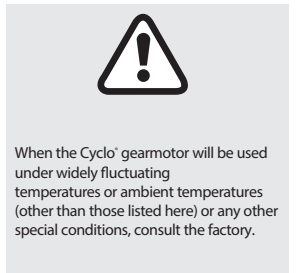

When the Cyclo® gearmotor will be used under widely fluctuating temperatures or ambient temperatures (other than those listed here) or any other special conditions, consult the factory.

For use in winter or relatively low ambient temperatures, use the lower viscosity oil specified for each ambient temperature range.

For consistent use in ambient temperatures outside of the range 32°F to 104°F (0°C to 40°C), consult factory.

Table 4.7b Ambient Temperatures

°F	14	32	50	68	86	104	122
°C	-10	0	10	20	30	40	50
ISO VG	68		100 / 150				
	150*			220 / 320 / 460			

* Only for Mobil Hi-Shock, Cyclo sizes 6130 to 6195, and minimum SF = 1.40

Lubrication continued

HORIZONTAL Mounted Reducer • SINGLE Reduction • Frame Sizes 6060 to 6275

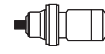

Frame Size	Reduction Ratio																
	3	5	6	8	11	13	15	17	21	25	29	35	43	51	59	71	87
6060, 6065 6070, 6075 6080, 6085 6090, 6095 6100, 6105, 610H 6110, 6115 6120, 6125, 612H	Grease		Maintenance Free Grease														
6130, 6135 6140, 6145, 614H 6160, 6165, 616H 6170, 6175 6180, 6185 6190, 6195 6205 6215 6225 6235 6245 6255 6265 6275	Oil																

HORIZONTAL Mounted Reducer • DOUBLE Reduction • Frame Sizes 6060DA to 6275DA

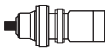

Frame Size	Reduction Ratio																									
	104	121	143	165	195	231	273	319	377	473	559	649	731	841	1003	1015	1247	1479	1849	2065	2537	3045	3481	4437	5133	6177
6060DA, 6065DA 6070DA, 6075DA 6090DA, 6095DA 6100DA, 6105DA 6120DA, 6125DA 6120DB, 6125DB	Maintenance Free Grease																									
6130DA, 6135DA 6130DB, 6135DB 6130DC, 6135DC 6140DA, 6140DB, 6140DC 6145DA, 6145DB, 6145DC 6160DA, 6165DA 6160DB, 6165DB 6170DA, 6175DA 6170DB, 6175DB 6180DA, 6185DA	Grease																									
6160DC, 6165DC 6170DC, 6175DC 6180DB, 6185DB 6190DA, 6195DA 6190DB, 6195DB 6205DA, 6205DB 6215DA, 6215DB 6225DA, 6225DB 6235DA, 6235DB 6245DA, 6245DB 6255DA, 6255DB 6265DA 6275DA	121	165	Oil																	377						

Lubrication continued

VERTICAL Mounted Gearmotor • SINGLE Reduction • Frame Sizes 6060 to 6275



Frame Size	Reduction Ratio																
	3	5	6	8	11	13	15	17	21	25	29	35	43	51	59	71	87
6060, 6065 6070, 6075 6080, 6085 6090, 6095 6100, 6105 6110, 6115 6120, 6125	Grease		Maintenance Free Grease														
6130, 6135 6140, 6145	Oil																
6160, 6165 6170, 6175 6180, 6185 6190, 6195 6205 6215 6225 6235 6245 6255 6265 6275	Forced Oil																

VERTICAL Mounted Gearmotor • DOUBLE Reduction • Frame Sizes 6060DA to 6275DA



Frame Size	Reduction Ratio																									
	104	121	143	165	195	231	273	319	377	473	559	649	731	841	1003	1015	1247	1479	1849	2065	2537	3045	3481	4437	5133	6177
6060DA, 6065DA 6070DA, 6075DA 6090DA, 6095DA 6100DA, 6105DA 6120DA, 6125DA 6120DB, 6125DB	Maintenance Free Grease																									
6130DA, 6135DA 6130DB, 6135DB 6130DC, 6135DC 6140DA, 6140DB, 6140DC 6145DA, 6145DB, 6145DC 6160DA, 6165DA 6160DB, 6165DB 6170DA, 6175DA 6170DB, 6175DB 6180DA, 6185DA	Grease																									
6160DC, 6165DC 6170DC, 6175DC 6180DB, 6185DB 6190DA, 6195DA 6190DB, 6195DB 6205DA, 6205DB 6215DA, 6215DB 6225DA, 6225DB 6235DA, 6235DB 6245DA, 6245DB 6255DA, 6255DB 6265DA 6275DA	121	165	Forced Oil																	377						

Oil Fill Quantities

Table 4.8 Oil Fill Quantities

Cyclo Horizontal Foot Mounted / Cyclo Horizontal V-Flange Mounted														
Size	613X	614X	616X	617X	618X	619X	6205	6215	6225	6235	6245	6255	6265	6275
US gal	0.18	0.18	0.37	0.50	0.66	1.1	1.5	2.2	2.6	4.0	4.2	5.5	7.7	14.8
liter	0.7	0.7	1.4	1.9	2.5	4	5.5	8.5	10	15	16	21	29	56
Size	616XDC	617XDC	618XDB	619XDA	619XDB	6205DA	6205DB	6215DA	6215DB	6225DA	6225DB	6235DA	6235DB	6245DA
US gal	0.40	0.63	0.92	1.5	1.6	1.6	1.6	2.6	2.6	2.9	2.9	4.5	4.5	4.8
liter	1.5	2.4	3.5	5.8	6	6	6	10	10	11	11	17	17	18
Size	6245DB	6255DA	6255DB	6265DA	6275DA									
US gal	4.8	6.1	6.1	8.5	15.9									
liter	18	23	23	32	60									

Cyclo Vertical V-Flange Mounted														
Size	613X	614X	616X	617X	618X	619X	6205	6215	6225	6235	6245	6255	6265	6275
US gal	0.29	0.29	0.26	0.50	0.53	0.71	1.5	2.0	2.6	3.2	4.0	11.1	13.5	(15.9)
liter	1.1	1.1	1	1.9	2	2.7	5.7	7.5	10	12	15	42	51	(60)
Size	616XDC	617XDC	618XDB	619XDA	619XDB	6205DA	6205DB	6215DA	6215DB	6225DA	6225DB	6235DA	6235DB	6245DA
US gal	0.26	0.50	0.53	0.71	0.71	2.9	2.9	3.7	3.7	4.8	4.8	6.1	6.1	7.7
liter	1	1.9	2	2.7	2.7	11	11	14	14	18	18	23	23	29
Size	6245DB	6255DA	6255DB	6265DA	6275DA									
US gal	7.7	11.1	11.1	13.5	(15.85)									
liter	29	42	42	51	(60.00)									

Cyclo Horizontal Flange Mounted														
Size	613X	614X	616X	617X	618X	619X	6205	6215	6225	6235	6245	6255	6265	6275
US gal	0.07	0.07	0.24	0.34	0.40	0.53	0.79	1.1	1.3	2.0	2.1	2.9	3.7	7.9
liter	0.25	0.25	0.9	1.3	1.5	2	3	4	5	7.5	8	11	14	30
Size	616XDC	617XDC	618XDB	619XDA	619XDB	6205DA	6205DB	6215DA	6215DB	6225DA	6225DB	6235DA	6235DB	6245DA
US gal	0.26	0.53	0.61	1.0	1.1	1.1	1.1	1.5	1.5	1.6	1.6	2.5	2.5	2.6
liter	1	2	2.3	3.8	4	4	4	5.5	5.5	6	6	9.5	9.5	10
Size	6245DB	6255DA	6255DB	6265DA										
US gal	2.6	3.4	3.4	4.5										
liter	10	13	13	17										

X = 0 or 5
() = With Trochoid Pump

Oil Fill Level

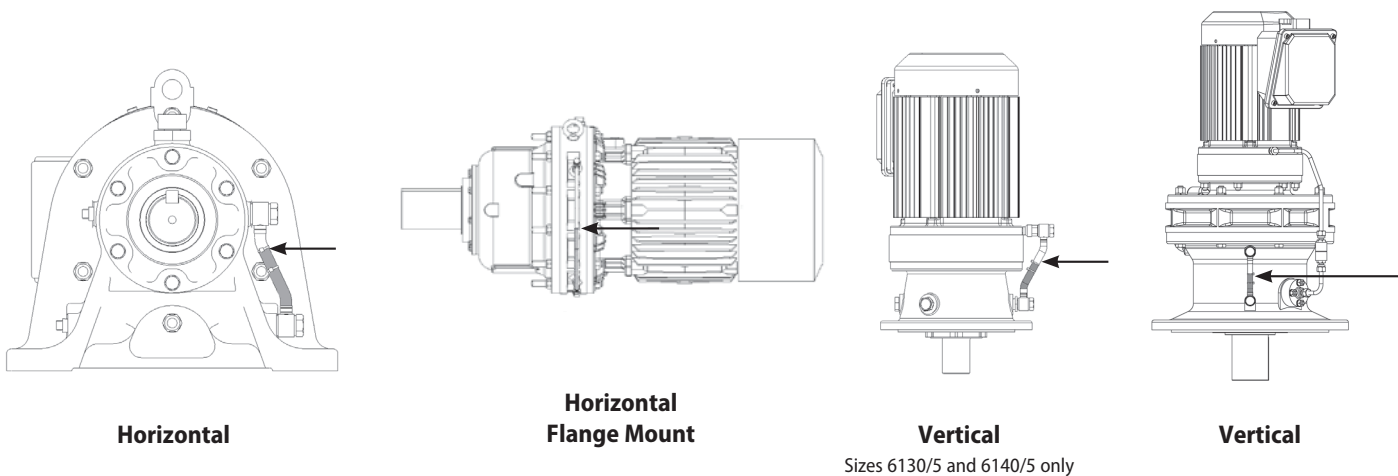

Table 4.9a Grease Fill Quantities for Maintenance Free Speed Reducers

Frame Size	606X	607X	608X	609X	610X	611X	612X	606XDA	607XDA	609XDA	610XDA	612XDA	612XDB
Speed Reduction Mechanism (1st stage)	0.9 (25)	0.9 (25)	1.4 (40)	2.1 (60)	4.2 (120)	6.7 (190)	8.8 (250)	0.9 (25)	0.9 (25)	0.9 (25)	0.9 (25)	0.9 (25)	2.1 (60)
Speed Reduction Mechanism (2nd stage)								0.9 (25)	0.9 (25)	2.1 (60)	4.2 (120)	8.8 (250)	8.8 (250)
Slow Speed Shaft Bearing	0.5 (15)	0.5 (15)	0.9 (25)	1.1 (30)	1.1 (30)	1.6 (45)	1.9 (55)	0.5 (15)	0.5 (15)	1.1 (30)	1.1 (30)	1.9 (55)	1.9 (55)

X = 0 or 5

Table 4.9b Grease Fill Quantities for Non-Maintenance Free Speed Reducers

Frame Size	613XDA	613XDB	613XDC	614XDA	614XDB	614XDC	616XDA	616XDB	616XDC	617XDA	617XDB	617XDC
Speed Reduction Mechanism (1st stage)	0.9 (25)	2.1 (60)	4.2 (120)	0.9 (25)	2.1 (60)	4.2 (120)	2.1 (60)	4.2 (120)	8.8 (250)	2.1 (60)	4.2 (120)	8.8 (250)
Speed Reduction Mechanism (2nd stage)	15.9 (450)	15.9 (450)	15.9 (450)	15.9 (450)	15.9 (450)	15.9 (450)	26.5 (750)	26.5 (750)	26.5 (750)	35.3 (1000)	35.3 (1000)	35.3 (1000)
Slow Speed Shaft Bearing	10.6 (300)	10.6 (300)	10.6 (300)	10.6 (300)	10.6 (300)	10.6 (300)	10.6 (300)	10.6 (300)	10.6 (300)	17.6 (500)	17.6 (500)	17.6 (500)
Frame Size	618XDA	618XDB	619XDA	619XDB	6205DA	6205DB	6215DA	6215DB	6225DA	6225DB	6235DA	6235DB
Speed Reduction Mechanism (1st stage)	4.2 (120)	15.9 (450)	11.6 (330)	15.9 (450)	11.6 (330)	15.9 (450)	15.9 (450)	26.5 (750)	15.9 (450)	35.3 (1000)	26.5 (750)	38.8 (1100)
Speed Reduction Mechanism (2nd stage)	38.8 (1100)	38.8 (1100)	52.9 (1500)	52.9 (1500)	52.9 (1500)	52.9 (1500)	70.5 (2000)	70.5 (2000)	88.2 (2500)	88.2 (2500)	141.1 (4000)	141.1 (4000)
Slow Speed Shaft Bearing	21.2 (600)	21.2 (600)	24.7 (700)	24.7 (700)	24.7 (700)	24.7 (700)	28.2 (800)	28.2 (800)	31.7 (900)	31.7 (900)	35.3 (1000)	35.3 (1000)
Frame Size	6245DA	6245DB	6255DA	6255DB	6265DA							
Speed Reduction Mechanism (1st stage)	26.5 (750)	38.8 (1100)	35.3 (1000)	52.9 (1500)	52.9 (1500)							
Speed Reduction Mechanism (2nd stage)	158.7 (4500)	158.7 (4500)	211.6 (6000)	211.6 (6000)	282.2 (8000)							
Slow Speed Shaft Bearing	38.8 (1100)	38.8 (1100)	42.3 (1200)	42.3 (1200)	45.9 (1300)							

X = 0 or 5

Lubrication continued

Table 4.10a Grease Fill Quantities for Normally Oil-Lubricated Units

Frame Size	6130	6160	6170	6180	6190	6215	6225	6235	6245	6255	6265
	6135 6140 6145	6165	6175	6185	6195 6205						
Speed Reduction Mechanism	15.9 (450)	26.5 (750)	35.3 (1000)	36.8 (1100)	52.9 (1500)	70.5 (2000)	88.2 (2500)	141.1 (4000)	158.7 (4500)	211.6 (6000)	282.2 (8000)
Slow Speed Shaft Bearing	10.6 (300)	10.6 (300)	17.6 (500)	21.2 (600)	24.7 (700)	28.2 (800)	31.7 (900)	35.3 (1000)	36.8 (1100)	42.3 (1200)	45.9 (1300)

oz. (g)

Table 4.10b Optional Greases

Application	Temperature Range		Grease Manufacturer	Brand	NGLI Grade	Cyclo Frame Size
	°F	°C				
Food Grade	14 to 104	-10 to 40	Ultrachem	Omnilube FGM	2	606Xto 612X
Low Temperature	-40 to 301	-40 to -1 ^[1]	ExxonMobil	Beacon 325	2	All
			Anderol	Royco 22 CF	2	All
High Temperature	105 to 180	40 to 80	ExxonMobil	Unirex N	2	All

NOTE: All units filled with grease other than Standard won't be considered Maintenance Free.

[1]: Consult factory for temperatures outside the established range.

Table 4.10c Optional Oils

Application	Temperature Range		Oil Manufacturer	Brand	ISO VG	Cyclo Frame Size
	°F	°C				
Food Grade	32 to 95	0 to 35	Kluber	Klubersynth UH1 6	460	613X to 616X ^[1]
Low Temp	-40 to -22	-40 to -30	Shell	Tellus S2 V	15	All

NOTE: [1]: Consult factory for Cyclo sizes not listed in the table

Motor Optional Conduit Box Location

Mounting Direction of Terminal Box

The terminal box mounting direction can be changed in units of 90°; specify the direction according to the table below when placing an order.

Cable port direction	Terminal box mounting position (As viewed from output shaft with motor being horizontal) ^[1]	
	Left side (N33)	Right side (N34)
Type A (N3A)		
Type B (N3B)		
Type C (N3C)		
Type D (N3D)		

Cable port direction	Terminal box mounting position (As viewed from output shaft with motor being horizontal) ^[1]	
	Top (N35)	Bottom (N36)
Type A (N3A)		
Type B (N3B)		
Type C (N3C)		
Type D (N3D)		

Note [1]: Arrow indicates direction of lead wires out of terminal boxes.

Table 4.11 Standard Position of Terminal Box and Direction of Lead Wires

	Horizontal Mounting Configuration (Horizontal Slow Speed Shaft)				Vertical Mounting Configuration (Vertical Slow Speed Shaft Down)	
	Standard Motor		Brake Motor		Standard Motor	Brake Motor
	3 Phase	AF Motor	3 Phase	AF Moto	3 Phase	3 Phase
Terminal Box Mounting Position	Left Side	Left Side	Left Side	Left Side	Left Side	Left Side
Cable Port Direction	B	B	B	B	A	A

Technical Information

Technical Information

Motor Cover Mounting Specifications

Refer to dimension FA or FB when designing the mounting space into which the gearmotor is to fit.

Dimension FA: The space necessary to remove the fan cover or brake cover without removing the motor from the equipment.

Dimension FB: Minimum clearance to provide adequate ventilation..

Notes:

1. In some cases, it may be necessary to move the gearmotor to remove the fan cover or brake cover.
2. Dimension FB is the minimum clearance when the fan cover is up against a closed wall.

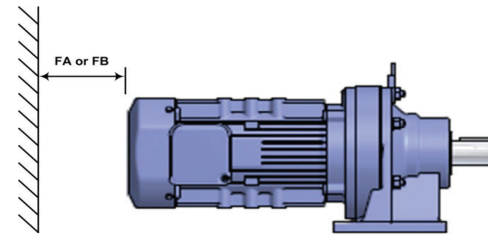

Figure 4.2 Motor Clearance

Table 4.12a Motor Clearance Requirements for IE1 motors (1/8 to 3/4 hp)

Units: inches (mm)

IE1 Motor			Standard 3-Phase Motor		3-Phase With Brake Motor	
Frame Size	HP x Pole	kW x Pole	FA	FB	FA	FB
V-63S	1/8 x 4	0.1 x 4	-	-	2.0 (49)	-
V-63M	1/4 x 4	0.2 x 4	1.9 (48)	0.8 (20)	2.5 (61)	0.8 (20)
V-63M	1/3 x 4	0.25 x 4	1.9 (48)	0.8 (20)	2.5 (61)	0.8 (20)
V-71M	1/2 x 4	0.4 x 4	1.9 (48)	0.8 (20)	2.5 (61)	0.8 (20)
V-80S	3/4 x 4	0.55 x 4	2.0 (49)	1.0 (25)	3.7 (93)	0.8 (20)
V-63S	1/8 x 4	0.1 x 4	-	-	2.0 (49)	-
V-63M	1/4 x 4	0.2 x 4	1.9 (48)	0.8 (20)	2.5 (61)	0.8 (20)
V-63M	1/3 x 4	0.25 x 4	1.9 (48)	0.8 (20)	2.5 (61)	0.8 (20)
V-71M	1/2 x 4	0.4 x 4	1.9 (48)	0.8 (20)	2.5 (61)	0.8 (20)
V-80S	3/4 x 4	0.55 x 4	2.0 (49)	1.0 (25)	3.7 (93)	0.8 (20)

Table 4.12b Motor Clearance Requirements for EP motors (1 to 75 hp)

Units: inches (mm)

IE3 Motor			3-Phase Without Brake Motor		3-Phase Brake (B) Motor	
Frame Size	HP x Pole	kW x Pole	FA	FB	FA	FB
N-80M	1 x 4	0.75 x 4	2.3 (58)	0.8 (20)	4.8 (122)	0.8 (20)
N-90S	1.5 x 4	1.1 x 4	2.3 (59)	0.8 (20)	5.0 (128)	0.8 (20)
N-90L	2 x 4	1.5 x 4	2.3 (59)	0.8 (20)	5.0 (128)	0.8 (20)
N-100L	3 x 4	2.2 x 4	2.4 (60)	0.8 (20)	5.4 (138)	0.8 (20)
N-112M	5 x 4	3.7 x 4	2.5 (63)	1.0 (25)	6.0 (153)	0.8 (20)
N-132S	7.5 x 4	5.5 x 4	2.5 (63)	1.0 (25)	6.0 (153)	0.8 (20)
N-132M	10 x 4	7.5 x 4	3.3 (84)	1.2 (30)	7.4 (189)	1 (25)
N-160M	15 x 4	11 x 4	3.3 (84)	1.2 (30)	7.4 (189)	1 (25)
N-160L	20 x 4	15 x 4	4.2 (107)	1.2 (30)	9.5 (242)	1.2 (30)
N-180MS	25 x 4	18.5 x 4	5.3 (134)	1.2 (30)	12.1 (308)	1.2 (30)
N-180M	30 x 4	22 x 4	5.3 (134)	1.2 (30)	12.1 (308)	1.2 (30)
N-180L	40 x 4	30 x 4	5.3 (134)	1.2 (30)	12.1 (308)	1.2 (30)
N-200L	50 x 4	37 x 4	5.3 (134)	1.2 (30)	13.6 (345)	1.2 (30)
N-200LL	60 x 4	45 x 4	6.7 (171)	1.2 (30)	14.8 (376)	1.2 (30)
N-225S	75 x 4	55 x 4	6.7 (171)	1.2 (30)	-	-

Motor Conduit Box Details

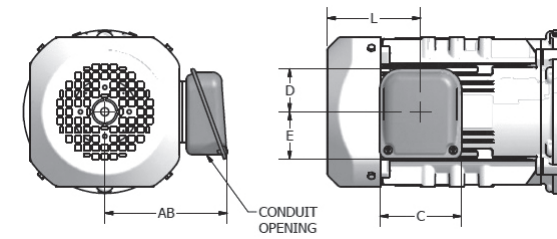

Figure 4.3 Indoor Duty (Optional) Box

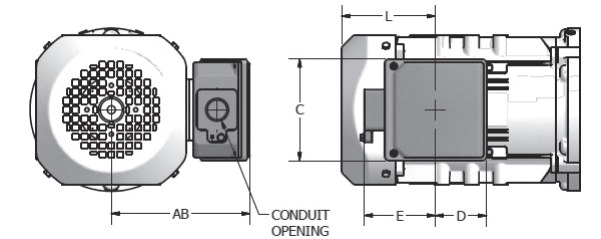

Figure 4.4 Global EP.NA and Outdoor Duty Box

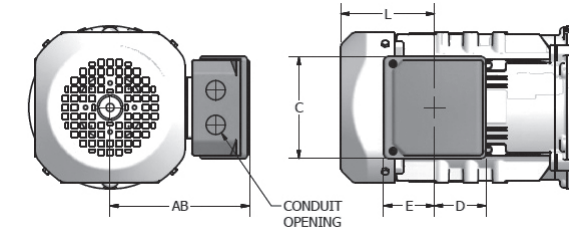

Figure 4.5 Global IE3 CE Box

Table 4.13 Terminal Box Mounting Centers

Units: inches

Frame Size	Duty Rating	General Dimensions				Without Brake		With Brake		Conduit Opening	Material
		AB	C	D	E	Available?	L	Available?	L		
V-63S	Indoor Duty (Optional)	4.11 (105)	3.35 (85)	2.09 (53)	1.69 (43)	yes	1.38 (35)	CF ⁽¹⁾	2.76 (70)	Ø0.90 (Ø23)	Steel
	Indoor Duty Brake (Optional)	4.32 (110)	3.94 (100)	2.29 (58)	2.10 (53)			yes		Ø0.90 (Ø23)	Steel
	Outdoor Duty (Optional)	4.98 (127)	3.94 (100)	2.42 (62)	2.76 (70)			yes		NPT1/2 ⁽²⁾	Steel
	Global	4.63 (118)	4.09 (104)	2.24 (57)	2.16 (55)			yes		NPT1/2	Al Diecast
	Global CE	4.63 (118)	4.09 (104)	2.24 (57)	2.16 (55)			yes		M16, M25	Al Diecast
	Global CE	4.63 (118)	4.09 (104)	2.24 (57)	2.16 (55)			yes		M16, M25	Al Diecast
VA-63S V-63M VA-63M V-71M	Indoor Duty (Optional)	4.11 (105)	3.35 (85)	2.09 (53)	1.69 (43)	yes	2.32 (59)	CF ⁽¹⁾	3.58 (91)	Ø0.90 (Ø23)	Steel
	Indoor Duty Brake (Optional)	4.32 (110)	3.94 (100)	2.29 (58)	2.10 (53)			yes		Ø0.90 (Ø23)	Steel
	Outdoor Duty (Optional)	4.98 (127)	3.94 (100)	2.42 (62)	2.76 (70)			yes		NPT1/2 ⁽²⁾	Steel
	Global	4.63 (118)	4.09 (104)	2.24 (57)	2.16 (55)			yes		NPT1/2	Al Diecast
	Global CE	4.63 (118)	4.09 (104)	2.24 (57)	2.16 (55)			yes		M16, M25	Al Diecast
	Global CE	4.63 (118)	4.09 (104)	2.24 (57)	2.16 (55)			yes		M16, M25	Al Diecast
VA-71M V-80S	Indoor Duty (Optional)	4.69 (119)	3.35 (85)	1.72 (44)	2.04 (52)	yes	3.82 (97)	CF ⁽¹⁾	5.51 (140)	Ø0.90 (Ø23)	Steel
	Indoor Duty Brake (Optional)	5.68 (144)	4.80 (122)	2.60 (66)	2.84 (72)			yes		Ø0.90 (Ø23)	Steel
	Outdoor Duty (Optional)	5.55 (141)	3.94 (100)	2.20 (56)	2.95 (75)			yes		G3/4 ⁽²⁾	Steel
	Global	5.67 (144)	4.92 (125)	2.50 (64)	3.43 (87)			yes		NPT3/4 ⁽²⁾	Al Diecast
	Global CE	5.71 (145)	4.92 (125)	2.50 (64)	2.47 (63)			yes		2 - M25	Al Diecast
	Global CE	5.71 (145)	4.92 (125)	2.50 (64)	2.47 (63)			yes		2 - M25	Al Diecast
VA-80S	Indoor Duty (Optional)	4.88 (124)	3.35 (85)	1.72 (44)	2.04 (52)	yes	3.94 (100)	CF ⁽¹⁾	6.38 (162)	Ø0.90 (Ø23)	Steel
	Indoor Duty Brake (Optional)	5.87 (149)	4.80 (122)	2.60 (66)	2.84 (72)			yes		Ø0.90 (Ø23)	Steel
	Outdoor Duty (Optional)	5.75 (146)	3.94 (100)	2.20 (56)	2.95 (75)			yes		G3/4 ⁽²⁾	Steel
	Global	5.86 (149)	4.92 (125)	2.50 (64)	3.43 (87)			yes		NPT3/4 ⁽²⁾	Al Diecast
	Global CE	5.91 (150)	4.92 (125)	2.50 (64)	2.47 (63)			yes		2 - M25	Al Diecast
	Global CE	5.91 (150)	4.92 (125)	2.50 (64)	2.47 (63)			yes		2 - M25	Al Diecast

(1) Please consult factory for brake configuration supporting this conduit box.

(2) Default thread option shown. Alternate thread options available. Please consult factory for alternate conduit thread options.

Table 4.13 Conduit Box Information (continued)

Frame Size	Duty Rating	General Dimensions				Without Brake		With Brake		Conduit Opening	Material
		AB	C	D	E	Available?	L	Available?	L		
N-80M	Indoor Duty (Optional)	4.85 (123)	3.35 (85)	1.72 (44)	2.04 (52)	Yes	3.82 (97)	CF ⁽¹⁾	6.32 (161)	Ø0.90 (Ø23)	Steel
	Indoor Duty Brake (Optional)	5.99 (152)	4.80 (122)	2.60 (66)	2.84 (72)			Yes		Ø0.90 (Ø23)	Steel
	Outdoor Duty (Optional)	5.87 (149)	3.94 (100)	2.20 (56)	2.95 (75)			Yes		G3/4 ⁽²⁾	Steel
	Global EP.NA	5.98 (152)	4.92 (125)	2.50 (64)	3.43 (87)			Yes		NPT3/4 ⁽²⁾	Al Diecast
	Global IE3 CE	6.02 (153)	4.92 (125)	2.50 (64)	2.47 (63)			Yes		2 - M25	Al Diecast
N-90S N-90L	Indoor Duty (Optional)	5.03 (128)	3.35 (85)	1.72 (44)	2.04 (52)	Yes	3.82 (97)	CF ⁽¹⁾	6.56 (167)	Ø0.90 (Ø23)	Steel
	Indoor Duty Brake (Optional)	6.17 (157)	4.80 (122)	2.60 (66)	2.84 (72)			Yes		Ø0.90 (Ø23)	Steel
	Outdoor Duty (Optional)	6.04 (154)	3.94 (100)	2.20 (56)	2.95 (75)			Yes		G3/4 ⁽²⁾	Steel
	Global EP.NA	6.16 (156)	4.92 (125)	2.50 (64)	3.43 (87)			Yes		NPT3/4 ⁽²⁾	Al Diecast
	Global IE3 CE	6.20 (158)	4.92 (125)	2.50 (64)	2.47 (63)			Yes		2 - M25	Al Diecast
N-100L N-112S	Indoor Duty (Optional)	5.93 (151)	3.94 (100)	2.09 (53)	2.29 (58)	Yes	4.53 (115)	CF ⁽¹⁾	7.60 (193)	Ø0.90 (Ø23)	Steel
	Indoor Duty Brake (Optional)	6.72 (171)	4.80 (122)	2.60 (66)	2.84 (72)			Yes		Ø0.90 (Ø23)	Steel
	Outdoor Duty (Optional)	7.21 (183)	4.84 (123)	2.52 (64)	3.43 (87)			Yes		G3/4 ⁽²⁾	Steel
	Global EP.NA	6.71 (170)	4.92 (125)	2.50 (64)	3.43 (87)			Yes		NPT3/4 ⁽²⁾	Al Diecast
	Global IE3 CE	6.75 (172)	4.92 (125)	2.50 (64)	2.47 (63)			Yes		2 - M25	Al Diecast
N-112M	Indoor Duty (Optional)	6.56 (167)	3.94 (100)	2.09 (53)	2.29 (58)	Yes	4.65 (118)	CF ⁽¹⁾	8.21 (209)	Ø0.90 (Ø23)	Steel
	Indoor Duty Brake (Optional)	7.35 (187)	4.80 (122)	2.60 (66)	2.84 (72)			Yes		Ø0.90 (Ø23)	Steel
	Outdoor Duty (Optional)	7.84 (199)	4.84 (123)	2.52 (64)	3.43 (87)			Yes		G3/4 ⁽²⁾	Steel
	Global EP.NA	7.34 (186)	4.92 (125)	2.50 (64)	3.43 (87)			Yes		NPT3/4 ⁽²⁾	Al Diecast
	Global IE3 CE	7.38 (188)	4.92 (125)	2.50 (64)	2.47 (63)			Yes		2 - M25	Al Diecast
N-132S	Indoor Duty (Optional)	6.56 (167)	3.94 (100)	2.09 (53)	2.29 (58)	Yes	4.65 (118)	CF ⁽¹⁾	8.21 (209)	Ø0.90 (Ø23)	Steel
	Indoor Duty Brake (Optional)	7.35 (187)	4.80 (122)	2.60 (66)	2.84 (72)			Yes		Ø0.90 (Ø23)	Steel
	Outdoor Duty (Optional)	7.84 (199)	4.84 (123)	2.52 (64)	3.43 (87)			Yes		G1 ⁽²⁾	Steel
	Global EP.NA	7.34 (186)	4.92 (125)	2.50 (64)	3.43 (87)			Yes		NPT1 ⁽²⁾	Al Diecast
	Global IE3 CE	7.38 (188)	4.92 (125)	2.50 (64)	2.47 (63)			Yes		2 - M25	Al Diecast
N-132M	Indoor Duty (Optional)	7.98 (203)	4.80 (122)	2.60 (66)	2.84 (72)	Yes	5.43 (138)	Yes	9.57 (243)	Ø1.69 (Ø43)	Steel
	Outdoor Duty (Optional)	9.26 (235)	6.06 (154)	3.11 (79)	4.13 (105)					G1 ⁽²⁾	Steel
	Global EP.NA	9.04 (230)	6.69 (170)	3.40 (86)	4.43 (113)					NPT1 ⁽²⁾	Al Diecast
	Global IE3 CE	9.04 (230)	6.69 (170)	3.40 (86)	3.51 (89)					2-M32	Al Diecast

(1) Please consult factory for brake configuration supporting this conduit box.

(2) Default thread option shown. Alternate thread options available. Please consult factory for alternate conduit thread options.

Table 4.13 Conduit Box Information (continued)

Frame Size	Duty Rating	General Dimensions				Without Brake		With Brake		Conduit Opening	Material
		AB	C	D	E	Available?	L	Available?	L		
N-160M	Indoor Duty (Optional)	7.98 (203)	4.80 (122)	2.60 (66)	2.84 (72)	Yes	5.43 (138)	Yes	9.57 (243)	Ø1.69 (Ø43)	Steel
	Outdoor Duty (Optional)	9.26 (235)	6.06 (154)	3.11 (79)	4.13 (105)					G1-1/4 ⁽²⁾	Steel
	Global EP.NA	9.04 (230)	6.69 (170)	3.40 (86)	4.43 (113)					NPT1-1/4 ⁽²⁾	Al Diecast
	Global IE3 CE	9.04 (230)	6.69 (170)	3.40 (86)	3.51 (89)					2-M32	Al Diecast
N-160L	Indoor Duty (Optional)	9.20 (234)	4.80 (122)	2.60 (66)	2.84 (72)	Yes	7.01 (178)	No	12.30 (313)	Ø1.69 (Ø43)	Steel
	Indoor Duty Brake (Optional)	10.16 (258)	6.54 (166)	3.48 (88)	3.89 (99)			Yes		Ø1.69 (Ø43)	Steel
	Outdoor Duty (Optional)	10.48 (266)	6.06 (154)	3.11 (79)	4.13 (105)			Yes		G1-1/4 ⁽²⁾	Steel
	Global EP.NA	10.26 (261)	6.69 (170)	3.40 (86)	4.43 (113)			Yes		NPT1-1/4 ⁽²⁾	Al Diecast
	Global IE3 CE	10.26 (261)	6.69 (170)	3.40 (86)	3.51 (89)			Yes		2-M32	Al Diecast
N-180MS N-180M	Indoor Duty (Optional)	11.69 (297)	6.54 (166)	3.48 (88)	3.89 (99)	Yes	9.06 (230)	Yes	15.91 (404)	Ø1.93 (Ø49)	Steel
	Outdoor Duty (Optional)	14.08 (358)	7.56 (192)	4.53 (115)	6.89 (175)					G1-1/4 ⁽²⁾	Cast Iron
	Global EP.NA	13.39 (340)	9.02 (229)	4.38 (111)	5.47 (139)					NPT1-1/4 ⁽²⁾	Cast Iron
	Global IE3 CE	13.39 (340)	9.02 (229)	4.38 (111)	4.43 (113)					2 - M40	Cast Iron
N-180L N-200L	Indoor Duty (Optional)	11.69 (297)	6.54 (166)	3.48 (88)	3.89 (99)	Yes	9.06 (230)	Yes	15.91 (404)	Ø1.93 (Ø49)	Steel
	Outdoor Duty (Optional)	14.08 (358)	7.56 (192)	4.53 (115)	6.89 (175)					G2 ⁽²⁾	Cast Iron
	Global EP.NA	13.39 (340)	9.02 (229)	4.38 (111)	5.47 (139)					NPT2 ⁽²⁾	Cast Iron
	Global IE3 CE	13.39 (340)	9.02 (229)	4.38 (111)	4.43 (113)					2 - M40	Cast Iron
N-200LL N-225S	Indoor Duty (Optional)	16.24 (413)	9.45 (240)	4.19 (106)	6.30 (160)	Yes	16.81 (427)			Ø3.03 (Ø77)	Steel
	Outdoor Duty (Optional)	19.03 (483)	10.16 (258)	5.28 (134)	11.50 (292)					G2-1/2 ⁽²⁾	Cast Iron
	Global EP.NA	16.54 (420)	10.63 (270)	5.14 (131)	6.22 (158)					NPT3 ⁽²⁾	Cast Iron
	Global IE3 CE	16.54 (420)	10.63 (270)	5.14 (131)	5.13 (130)					2 - M63	Cast Iron

(1) Please consult factory for brake configuration supporting this conduit box.

(2) Default thread option shown. Alternate thread options available. Please consult factory for alternate conduit thread options.

Motor continued

Fractional Motor Performance Data - 60Hz Operation

Table 4.14a Standard Three Phase, 230/460V, 60Hz, 1800 RPM Synchronous Speed, TEFC - UL Recognized

Motor Capacity		Frame Size	Full Load			Current (A)				Starting Torque % of FL	Breakdown Torque % of FL	Nominal Efficiency %	Power Factor %	NEMA Code Letter
HP	kW		Rated RPM	Torque		Full Load		No Load % of FL	Starting % of FL					
				in-lbs	N-m	230V	460V							
1/8**	0.1	V-63S	1730	4.55	0.514	0.66	0.33	86.1	424	326	308	63.3	60.0	K
1/4	0.2	V-63M	1730	9.10	1.03	1.12	0.56	79.6	464	300	287	69.2	65.1	K
1/3	0.25	V-63M	1700	12.2	1.38	1.24	0.62	72.0	419	237	226	70.1	72.0	G
1/2	0.4	V-71M	1750	18.0	2.03	2.15	1.08	77.7	456	295	276	71.5	65.4	J
3/4	0.55	V-80S	1720	27.5	3.11	2.47	1.24	68.4	500	266	261	76.5	73.1	H

** 1/8 HP is TENV

Table 4.14b Standard Three Phase, 240/480V, 60Hz, 1800 RPM Synchronous Speed, TEFC - UL Recognized

Motor Capacity		Frame Size	Full Load			Current (A)				Starting Torque % of FL	Breakdown Torque % of FL	Nominal Efficiency %	Power Factor %	NEMA Code Letter
HP	kW		Rated RPM	Torque		Full Load		No Load % of FL	Starting % of FL					
				in-lbs	N-m	240V	480V							
1/8**	0.1	V-63S	1740	4.53	0.512	0.69	0.35	87.4	429	364	341	61.9	56.3	L
1/4	0.2	V-63M	1740	9.05	1.02	1.16	0.58	83.6	466	335	317	68.2	61	K
1/3	0.25	V-63M	1710	12.3	1.39	1.27	0.63	77.0	429	268	238	69.8	68.1	H
1/2	0.4	V-71M	1750	18.0	2.04	2.27	1.13	83.2	460	328	303	70.4	60.4	K
3/4	0.55	V-80S	1730	27.3	3.09	2.52	1.26	73.4	508	294	285	76.0	69.2	H

** 1/8 HP is TENV

Table 4.14c Non-Standard Three Phase, 230/460V, 60Hz, 1800 RPM Synchronous Speed, TEFC - CSA Approved

Motor Capacity		Frame Size	Full Load			Current (A)				Starting Torque % of FL	Breakdown Torque % of FL	Nominal Efficiency %	Power Factor %	NEMA Code Letter
HP	kW		Rated RPM	Torque		Full Load		No Load % of FL	Starting % of FL					
				in-lbs	N-m	230V	460V							
1/8**	0.1	V-63S	1730	4.55	0.514	0.66	0.33	86.1	424	326	308	63.3	60.0	K
1/4	0.2	V-63M	1730	9.10	1.03	1.12	0.56	79.6	464	300	287	69.2	65.1	K
1/3	0.25	V-63M	1700	12.2	1.38	1.24	0.62	72.0	419	237	226	70.1	72.0	G
1/2	0.4	V-71M	1750	18.0	2.03	2.15	1.08	77.7	456	295	276	71.5	65.4	J
3/4	0.55	V-80S	1720	27.5	3.11	2.47	1.24	68.4	500	266	261	76.5	73.1	H

** 1/8 HP is TENV

Table 4.14d Non-Standard Three Phase, 575V, 60Hz, 1800 RPM Synchronous Speed, TEFC - CSA Approved

Motor Capacity		Frame Size	Full Load			Current (A)				Starting Torque % of FL	Breakdown Torque % of FL	Nominal Efficiency %	Power Factor %	NEMA Code Letter
HP	kW		Rated RPM	Torque		Full Load		No Load % of FL	Starting % of FL					
				in-lbs	N-m	240V	480V							
1/8**	0.1	V-63S	1720	4.58	0.518	0.28		91.8	464	376	391	65.5	54.1	M
1/4	0.2	V-63M	1730	9.10	1.03	0.48		85.4	458	316	340	69.4	60.1	K
1/3	0.25	V-63M	1710	12.2	1.38	0.52		78.8	423	250	270	71.3	67.5	H
1/2	0.4	V-71M	1700	18.5	2.09	0.79		75.8	468	309	300	75.2	63.1	J
3/4	0.55	V-80S	1700	27.8	3.14	1.00		74.0	530	260	268	75.4	71.4	H

** 1/8 HP is TENV

Fractional AF-Motor (AV) Performance Data, Inverter Ready - 60Hz Operation

Table 4.15a Three Phase, 230/460V, 60Hz, 1800 RPM Synchronous Speed, 10:1 Constant Torque Speed Range TEFC

Motor Capacity		Frame Size	Wiring	Full Load Torque		Voltage V	60 Hz Current Amp	Speed RPM	Voltage V	6 Hz Current Amp	Speed RPM	No Load Current @ 60 Hz
HP	kW			in-lbs	N-m							
			Low Voltage	230	0.98	34	0.74	0.92				
1/4	0.2	VA-63M	High Voltage	9.6	1.08	460	0.91	1765	68	0.79	125	0.87
			Low Voltage			230	1.8		34	1.6		1.74
1/3	0.25	VA-63M	High Voltage	12	1.36	460	0.94	1755	78	0.87	125	0.87
			Low Voltage			230	1.9		34	1.7		1.74
1/2	0.4	VA-71M	High Voltage	19.2	2.17	460	1.3	1750	70	1.1	115	1.21
			Low Voltage			230	2.6		35	2.3		2.42
3/4	0.55	VA-80S	High Voltage	26.3	2.97	460	1.7	1760	62	1.6	125	1.54
			Low Voltage			230	3.3		31	3.1		3.07

Table 4.15b Three Phase, 230/460V, 60Hz, 1800 RPM Synchronous Speed, 10:1 Constant Torque Speed Range TEFC - CSA Approved

Motor Capacity		Frame Size	Wiring	Full Load Torque		Voltage V	60 Hz Current Amp	Speed RPM	Voltage V	6 Hz Current Amp	Speed RPM	No Load Current @ 60 Hz
HP	kW			in-lbs	N-m							
			Low Voltage	230	0.98	34	0.74	0.92				
1/4	0.2	VA-63M	High Voltage	9.57	1.08	460	0.91	1765	68	0.79	125	0.87
			Low Voltage			230	1.8		34	1.6		1.74
1/3	0.25	VA-63M	High Voltage	12.0	1.36	460	0.94	1755	78	0.87	125	0.87
			Low Voltage			230	1.9		34	1.7		1.74
1/2	0.4	VA-71M	High Voltage	19.3	2.17	460	1.3	1750	70	1.1	115	1.21
			Low Voltage			230	2.6		35	2.3		2.42
3/4	0.55	VA-80S	High Voltage	26.3	2.97	460	1.7	1765	62	1.5	145	1.54
			Low Voltage			230	3.3		31	2.9		3.08

Table 4.15c Three Phase, 575V, 60Hz, 1800 RPM Synchronous Speed, 10:1 Constant Torque Speed Range TEFC - CSA Approved

Motor Capacity		Frame Size	Full Load Torque		Voltage V	60 Hz Current Amp	Speed RPM	Voltage V	6 Hz Current Amp	Speed RPM	No Load Current @ 60 Hz
HP	kW		in-lbs	N-m							
1/4	0.2	VA-63M	9.57	1.08	575	0.7	1765	77	0.5	85	0.62
1/3	0.25	VA-63M	12.0	1.36	575	0.7	1755	95	0.7	120	0.62
1/2	0.4	VA-71M	19.4	2.17	575	0.94	1745	88	0.86	110	0.86
3/4	0.55	VA-80S	26.3	2.97	575	1.3	1765	76	1.1	140	0.98

** 1/8 HP is TENV

Motor Performance Data - (EP) Motor, 60Hz Operation

Table 4.16a Three Phase, 230/460v, 60Hz, 1800 RPM Synchronous Speed, TEFC

Motor Capacity		Frame Size	Full Load			Current (A)				Starting Torque % of FL	Breakdown Torque % of FL	Nominal Efficiency %	Power Factor %	NEMA Code Letter
HP	kW		Rated RPM	Torque		Full Load		No Load % of FL	Starting % of FL					
				in-lbs	N-m	230V	460V							
1	0.75	N-80M	1730	36.6	4.14	3.06	1.53	62.0	692	343	403	85.5	72.0	K
1.5	1.1	N-90S	1730	53.7	6.07	4.15	2.08	52.1	659	277	341	86.5	76.5	J
2	1.5	N-90L	1730	73.2	8.28	5.61	2.80	52.7	694	284	356	86.5	77.2	J
3	2.2	N-100L	1740	107	12.1	7.66	3.83	47.5	824	317	389	89.5	80.7	K
5	3.7	N-112M	1750	179	20.2	12.3	6.17	44.5	821	244	379	89.5	83.9	K
7.5	5.5	N-132S	1760	264	29.8	17.8	8.90	42.9	1000	290	461	91.7	84.2	L
10	7.5	N-132M	1760	360	40.7	24.4	12.2	36.1	606	193	277	91.7	84.1	G
15	11	N-160M	1770	525	59.3	38.4	19.2	48.0	736	274	369	92.4	77.8	J
20	15	N-160L	1770	716	80.9	47.7	23.8	36.5	828	227	351	93.0	85.0	J
25	18.5	N-180MS	1780	878	99.2	56.9	28.5	31.7	805	245	308	93.6	86.4	J
30	22	N-180M	1780	1040	118	67.4	33.7	28.8	673	206	258	93.6	87.1	G
40	30	N-180L	1780	1420	161	91.6	45.8	29.5	792	242	295	94.1	87.0	J
50	37	N-200L	1780	1760	198	113	56.5	31.7	890	276	328	94.5	86.7	K
60	45	N-200LL	1780	2140	241	138	69.0	37.7	962	308	393	95.0	86.3	K
75	55	N-225S	1780	2610	295	166	82.8	34.5	980	301	381	95.4	87.5	K

Motor Performance Data - (EP) 60Hz Operation (continued)

Table 4.17 Three Phase, 575V, 60Hz, 1800 RPM Synchronous Speed, TEFC

Motor Capacity		Frame Size	Full Load			Current (A)			Starting Torque % of FL	Breakdown Torque % of FL	Nominal Efficiency %	Power Factor %	NEMA Code Letter
HP	kW		Rated RPM	Torque		Full Load	No Load % of FL	Starting % of FL					
				in-lbs	N-m	575V							
1	0.75	N-80M	1740	36.4	4.12	1.36	72.7	768	430	500	85.5	64.4	M
1.5	1.1	N-90S	1740	53.4	6.04	1.69	57.8	743	313	386	86.5	74.5	K
2	1.5	N-90L	1730	73.2	8.28	2.22	52.3	685	272	341	86.5	77.9	J
3	2.2	N-100L	1740	107	12.1	3.05	47.2	839	322	404	89.5	80.8	K
5	3.7	N-112M	1750	179	20.2	4.86	42.0	798	230	355	89.5	84.9	J
7.5	5.5	N-132S	1760	264	29.8	7.12	42.5	957	263	429	91.7	84.7	L
10	7.5	N-132M	1760	360	40.7	10.1	43.9	704	230	332	91.7	81.3	H
15	11	N-160M	1760	528	59.7	14.5	41.7	710	237	331	92.4	82.3	H
20	15	N-160L	1770	716	80.9	19.4	41.1	915	257	396	93.0	83.3	K
25	18.5	N-180MS	1780	878	99.2	22.8	35.2	916	276	350	93.6	86.1	K
30	22	N-180M	1780	1040	118	26.8	29.9	779	230	293	93.6	87.2	H
40	30	N-180L	1780	1420	161	37.0	31.5	857	263	321	94.1	86.1	J
50	37	N-200L	1780	1760	198	45.5	36.0	954	297	352	94.5	85.9	K
60	45	N-200LL	1780	2140	241	55.7	40.5	1040	324	422	95.0	85.4	L
75	55	N-225S	1780	2610	295	67.9	40.5	1110	355	442	95.4	85.3	L

Table 4.16b Three Phase, 240/480V, 60Hz, 1800 RPM Synchronous Speed, TEFC

Motor Capacity		Frame Size	Full Load			Current (A)				Starting Torque % of FL	Breakdown Torque % of FL	Nominal Efficiency %	Power Factor %	NEMA Code Letter
HP	kW		Rated RPM	Torque		Full Load		No Load % of FL	Starting % of FL					
				in-lbs	N-m	240V	480V							
1	0.75	N-80M	1740	36.4	4.12	3.05	1.52	66.2	723	380	439	85.5	69.2	L
1.5	1.1	N-90S	1740	53.4	6.04	4.09	2.05	56.6	704	310	375	86.5	74.1	J
2	1.5	N-90L	1730	73.2	8.28	5.54	2.77	57.8	722	316	387	86.5	74.5	K
3	2.2	N-100L	1750	106	12.0	7.53	3.77	52.1	911	352	446	89.5	78.4	L
5	3.7	N-112M	1760	178	20.1	12.1	6.06	49.3	886	268	421	89.5	81.7	K
7.5	5.5	N-132S	1760	264	29.8	17.5	8.76	47.6	1060	321	506	91.7	82.0	M
10	7.5	N-132M	1760	360	40.7	23.8	11.9	40.3	652	212	308	91.7	82.2	H
15	11	N-160M	1770	525	59.3	38.7	19.3	54.0	760	305	405	92.4	74.0	K
20	15	N-160L	1770	716	80.9	46.5	23.2	41.0	893	251	387	93.0	83.3	K
25	18.5	N-180MS	1780	878	99.2	55.1	27.6	35.2	881	268	340	93.6	85.3	K
30	22	N-180M	1780	1040	118	64.9	32.4	29.9	748	224	285	93.6	86.5	H
40	30	N-180L	1780	1420	161	88.8	44.4	33.3	867	266	326	94.1	85.9	J
50	37	N-200L	1780	1760	198	110.0	55.1	35.7	968	304	361	94.5	85.2	K
60	45	N-200LL	1780	2140	241	135.0	67.6	42.0	1050	329	430	95.0	84.4	L
75	55	N-225S	1780	2610	295	161.0	80.6	38.7	1070	321	417	95.4	86.1	L

Technical Information

Technical Information

Motor Performance Data - Small kW CE Motor, 50Hz Operation

Table 4.18a IE1 Three Phase, 220/380V, 50Hz, 1500 RPM Synchronous Speed, TEFC - CE (Not for EU or UK)

Motor Capacity		Frame Size	Full Load (A)			Current				Starting Torque % of FL	Breakdown Torque % of FL	Nominal Efficiency %	Power Factor %	NEMA Code Letter
HP	kW		Rated RPM	Torque		Full Load		No Load % of FL	Starting % of FL					
				in-lbs	N-m	220V	380V							
1/8**	0.1	V-63S	1400	6.03	0.682	0.6	0.35	78.3	371	230	226	63.3	69.1	H
1/4	0.2	V-63M	1390	12.2	1.37	1.05	0.61	71.5	361	206	206	67.6	73.7	F
1/3	0.25	V-63M	1360	15.5	1.75	1.22	0.71	61.4	338	195	181	69.1	77.8	E
1/2	0.4	V-71M	1410	24.0	2.71	2.06	1.19	68.3	353	201	204	69.7	73.5	F
3/4	0.55	V-80S	1400	33.2	3.75	2.45	1.42	58.5	373	206	196	73.4	80.2	E

** 1/8 HP is TENV

Table 4.18b IE1 Three Phase, 230/400V, 50Hz, 1500 RPM Synchronous Speed, TEFC - CE (Not for EU or UK)

Motor Capacity		Frame Size	Full Load (A)			Current				Starting Torque % of FL	Breakdown Torque % of FL	Nominal Efficiency %	Power Factor %	NEMA Code Letter
HP	kW		Rated RPM	Torque		Full Load		No Load % of FL	Starting % of FL					
				in-lbs	N-m	230V	400V							
1/8**	0.1	V-63S	1420	5.95	0.672	0.62	0.36	83.6	361	261	255	62.1	64.9	H
1/4	0.2	V-63M	1410	12.0	1.35	1.08	0.62	77.3	371	236	233	67.1	69.5	G
1/3	0.25	V-63M	1380	15.3	1.73	1.22	0.7	68.4	371	225	205	69.4	74.2	F
1/2	0.4	V-71M	1420	23.8	2.69	2.13	1.23	75.6	366	229	229	68.5	68.7	G
3/4	0.55	V-80S	1410	32.9	3.72	2.45	1.41	65.2	390	225	219	73.6	76.7	F

** 1/8 HP is TENV

Table 4.18c IE1 Three Phase, 240/415V, 50Hz, 1500 RPM Synchronous Speed, TEFC - CE (Not for EU or UK)

Motor Capacity		Frame Size	Full Load (A)			Current				Starting Torque % of FL	Breakdown Torque % of FL	Nominal Efficiency %	Power Factor %	NEMA Code Letter
HP	kW		Rated RPM	Torque		Full Load		No Load % of FL	Starting % of FL					
				in-lbs	N-m	240V	415V							
1/8**	0.1	V-63S	1420	5.95	0.672	0.65	0.37	88.1	378	286	277	60.9	60.9	J
1/4	0.2	V-63M	1410	12.0	1.35	1.1	0.64	80.9	375	260	253	66.4	65.7	H
1/3	0.25	V-63M	1390	15.2	1.72	1.23	0.71	73.0	380	247	223	69.5	70.6	G
1/2	0.4	V-71M	1430	23.6	2.67	2.23	1.29	80.6	364	250	247	67.0	64.4	H
3/4	0.55	V-80S	1420	32.7	3.7	2.46	1.43	70.6	413	248	237	73.6	73.1	G

** 1/8 HP is TENV

Table 4.18d IE3 Three Phase, 230/400V, 50Hz, 1500 RPM Synchronous Speed, 6 lead, CE Marked, TEFC (for EU or UK)

Motor Capacity		Frame Size	Full Load Ratings							Current as % Full Load		Torque as % of Full Load	
HP	kW		Current		RPM	Torque		Nominal Efficiency	Power Factor	No Load	Starting	Starting	Breakdown
			230V	400V		N-m	in-lbs						
1/8**	0.1**	V-63S	0.62	0.35	1420	0.672	5.95	62.1	0.65	83.6	361	261	255
1/8	0.12	VA-63S	0.7	0.41	1430	0.8	7.08	72.5	0.59	84.3	571	283	346
1/4	0.2	VA-63M	1.08	0.63	1410	1.35	11.95	76.5	0.60	77.8	565	277	331
1/3	0.25	VA-63M	1.19	0.69	1400	1.71	15.13	76.1	0.69	70.6	513	219	262
1/2	0.4	VA-71M	1.86	1.08	1420	2.68	23.72	79.1	0.68	72.6	559	311	362
3/4	0.55	N-80S	2.31	1.33	1430	3.66	32.39	83.5	0.71	36.4	647	293	365

** 0.1 kW (1/8 HP) is TENV and IE1

Motor Performance Data - CE Motor, 50Hz Operation

Table 4.19a Three Phase, 220/380V, 50Hz, 1500 RPM Synchronous Speed, TEFC

Motor Capacity		Frame Size	Full Load			Current (A)				Starting Torque % of FL	Breakdown Torque % of FL	Nominal Efficiency %	Power Factor %	NEMA Code Letter
HP	kW		Rated RPM	Torque		Full Load		No Load % of FL	Starting % of FL					
				in-lbs	N-m	220V	380V							
1	0.75	N-80M	1430	44.3	5.01	3.46	2.00	69.5	608	383	402	84.7	67.9	K
1.5	1.1	N-90S	1430	65.0	7.35	4.49	2.59	57.1	637	296	343	85.4	75.1	J
2	1.5	N-90L	1420	89.2	10.1	6.10	3.52	57.7	607	304	338	85.4	75.5	H
3	2.2	N-100L	1440	129	14.6	8.58	4.96	54.8	796	344	418	88.6	78.0	K
4	3.0	N-112S	1430	177	20.0	11.3	6.50	48.1	712	316	365	87.7	80.8	J
5	3.7	N-112M	1460	214	24.2	13.5	7.80	50.7	777	266	378	89.6	81.2	J
5.5	4.0	N-112M	1450	233	26.3	14.4	8.30	47.7	730	266	378	88.9	82.9	J
7.5	5.5	N-132S	1460	318	36.0	-	11.5	52.0	950	316	471	90.6	80.7	L
10	7.5	N-132M	1460	434	49.1	-	15.8	47.2	620	213	315	90.8	79.6	H
15	11	N-160M	1460	636	71.9	-	22.3	40.4	578	200	283	91.4	81.6	G
20	15	N-160L	1470	862	97.4	-	30.5	45.2	649	230	304	92.6	80.6	H
25	18.5	N-180MS	1480	1060	119	-	35.6	38.8	772	245	338	94.0	83.5	J
30	22	N-180M	1480	1260	142	-	41.9	32.9	656	206	284	93.5	85.4	G
40	30	N-180L	1480	1710	194	-	58.9	41.4	731	239	344	94.3	82.6	H
50	37	N-200L	1480	2110	239	-	70.5	35.9	740	239	325	94.2	84.6	H
60	45	N-200LL	1480	2570	290	-	84.0	37.1	826	285	370	94.6	86.4	J
75	55	N-225S	1480	3140	355	-	99.5	34.8	892	323	369	95.0	87.9	J

Table 4.19b Three Phase, 230/400V, 50Hz, 1500 RPM Synchronous Speed, TEFC

Motor Capacity		Frame Size	Full Load			Current (A)				Starting Torque % of FL	Breakdown Torque % of FL	Nominal Efficiency %	Power Factor %	NEMA Code Letter
HP	kW		Rated RPM	Torque		Full Load		No Load % of FL	Starting % of FL					
				in-lbs	N-m	230V	400V							
1	0.75	N-80M	1440	44.0	4.97	3.54	2.05	75.8	643	423	446	84.6	62.7	L
1.5	1.1	N-90S	1440	64.5	7.29	4.50	2.60	64.4	672	336	387	85.6	71.1	K
2	1.5	N-90L	1430	88.6	10.0	6.17	3.56	65.3	631	338	375	85.8	72.3	J
3	2.2	N-100L	1450	128	14.5	8.56	4.95	63.3	839	382	465	88.7	74.1	L
4	3.0	N-112S	1440	176	19.9	11.2	6.45	56.0	767	352	419	87.9	76.9	K
5	3.7	N-112M	1460	214	24.2	13.7	7.90	58.8	805	294	420	89.0	77.5	K
5.5	4.0	N-112M	1460	231	26.2	14.4	8.30	56.0	768	273	388	89.1	78.8	K
7.5	5.5	N-132S	1460	318	36.0	-	11.6	59.5	985	351	524	90.6	76.2	M
10	7.5	N-132M	1460	434	49.1	-	16.0	54.5	739	206	350	91.2	75.5	K
15	11	N-160M	1470	632	71.5	-	22.2	61.2	714	257	378	91.5	73.0	J
20	15	N-160L	1480	856	96.8	-	30.6	53.3	681	256	338	92.5	76.3	J
25	18.5	N-180MS	1480	1060	119	-	35.4	46.0	817	272	375	93.9	80.1	K
30	22	N-180M	1480	1260	142	-	40.9	39.9	707	227	314	93.8	82.7	H
40	30	N-180L	1480	1710	194	-	59.1	49.7	767	265	382	94.0	78.2	J

Table continued on next page.

Motor Performance Data - IE3 CE Motor, 50Hz Operation (continued)

Table 4.19b continued... Three Phase, 230/400V, 50Hz, 1500 RPM Synchronous Speed, TEFC

Motor Capacity		Frame Size	Full Load			Current (A)				Starting Torque % of FL	Breakdown Torque % of FL	Nominal Efficiency %	Power Factor %	NEMA Code Letter
HP	kW		Rated RPM	Torque		Full Load		No Load % of FL	Starting % of FL					
				in-lbs	N-m	230V	400V							
50	37	N-200L	1480	2110	239	-	69.5	42.9	791	266	361	94.1	81.4	J
60	45	N-200LL	1480	2570	290	-	82.5	43.7	886	317	411	94.6	83.5	K
75	55	N-225S	1480	3140	355	-	97.0	40.3	963	358	409	95.1	85.5	K

Table 4.20 Three Phase, 240/415V, 50Hz, 1500 RPM Synchronous Speed, TEFC

Motor Capacity		Frame Size	Full Load			Current (A)				Starting Torque % of FL	Breakdown Torque % of FL	Nominal Efficiency %	Power Factor %	NEMA Code Letter
HP	kW		Rated RPM	Torque		Full Load		No Load % of FL	Starting % of FL					
				in-lbs	N-m	240V	415V							
1	0.75	N-80M	1450	43.7	4.94	3.65	2.11	80.1	629	461	484	84.1	59.4	L
1.5	1.1	N-90S	1440	64.5	7.29	4.57	2.64	69.7	688	368	422	85.5	67.4	K
2	1.5	N-90L	1440	88.0	9.95	6.29	3.63	72.2	642	366	406	85.4	67.3	K
3	2.2	N-100L	1450	128	14.5	8.83	5.10	69.3	844	412	502	88.3	69.3	M
4	3.0	N-112S	1440	176	19.9	11.3	6.55	62.5	785	387	458	87.9	73.2	L
5	3.7	N-112M	1460	214	24.2	13.9	8.00	65.6	827	319	453	89.2	72.7	L
5.5	4.0	N-112M	1460	231	26.2	14.5	8.35	62.9	792	294	418	89.0	74.8	K
7.5	5.5	N-132S	1470	316	35.7	-	11.9	67.1	1000	378	564	90.2	72.0	N
10	7.5	N-132M	1470	431	48.7	-	16.2	61.4	660	254	378	90.6	71.1	J
15	11	N-160M	1470	632	71.5	-	22.4	53.2	648	249	354	91.6	74.6	H
20	15	N-160L	1480	856	96.8	-	31.2	59.9	693	275	364	92.2	72.3	J
25	18.5	N-180MS	1490	1050	119	-	35.7	52.4	840	292	404	93.8	76.7	K
30	22	N-180M	1480	1260	142	-	40.8	45.8	735	245	339	93.6	80.2	J
40	30	N-180L	1480	1710	194	-	60.2	55.6	781	285	411	93.6	74.2	K
50	37	N-200L	1480	2110	239	-	70.0	48.3	816	287	391	94.1	78.2	K
60	45	N-200LL	1480	2570	290	-	82.5	49.3	919	341	442	94.5	80.7	L
75	55	N-225S	1480	3140	355	-	96.5	45.1	1000	386	441	95.1	83.1	L

Notes on Inverter Operation

Please refer to Frequently Asked Questions on page 1.6.

Motor continued

Standard Wiring Diagrams

Illustrated below are the wiring diagrams for our standard motors. For additional information please refer to the motor name plate. Due to changes in design features, this diagram may not always agree with that on the motor. If different, the motor diagram found inside the conduit box cover should be used.

Table 4.21 Wiring Configuration for 230/460V, 60Hz and 575V, 60Hz by EP.NA Motor

Motor HP x P	230/460V, 60Hz			575V, 60Hz		
	Internal	No. of Leads	Diagram	Internal	No. of Leads	Diagram
1/8 x 4	WYE	9	9-Lead WYE	WYE	3	3-Lead
1/4 x 4						
1/3 x 4						
1/2 x 4						
3/4 x 4						
1 x 4						
1.5 x 4						
2 x 4						
3 x 4	DELTA	9	9-Lead DELTA	DELTA	3	3-Lead
5 x 4						
7.5 x 4						
10 x 4						
15 x 4						
20 x 4						
25 x 4						
30 x 4						
40 x 4						
50 x 4						
60 x 4						
75 x 4						

Figure 4.28b 9-Lead WYE

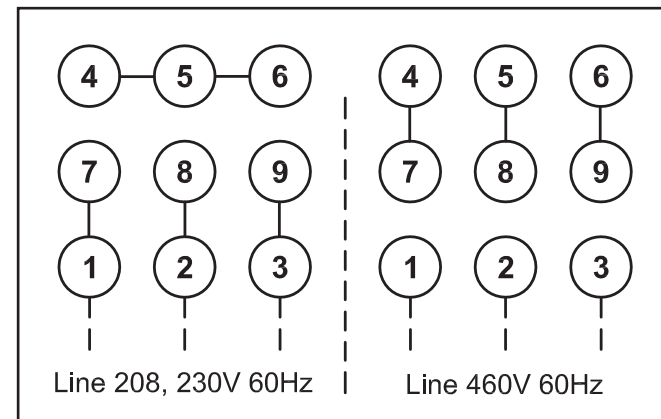

Figure 4.28c 9-Lead DELTA

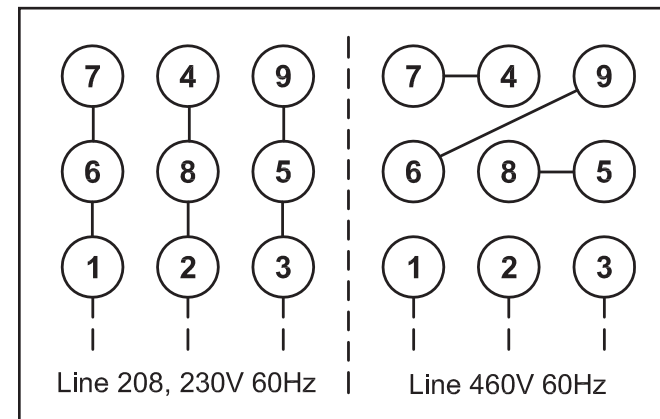
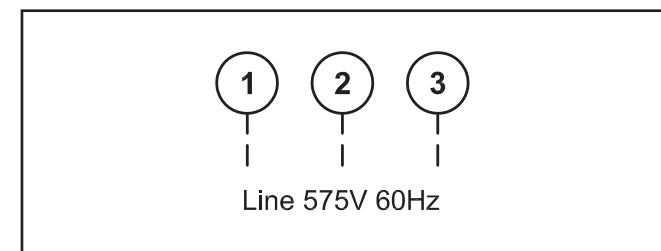

Figure 4.28d 3-Lead SINGLE



Motor continued

Three-Phase IE3 CE Motors

Table 4.22 Wiring Configuration by IE3 CE Motor

Motor kW x P	Voltage Configuration	Wiring Diagram
.75 x 4	220/380V, 50Hz Three Phase	DELTA-WYE
1.1 x 4		
1.5 x 4		
2.2 x 4		
3.0 x 4		
3.7 x 4		
5.5 x 4		
7.5 x 4	380V, 50Hz Three Phase	WYE-Start DELTA-Run
11 x 4		
15 x 4		
18.5 x 4		
22 x 4		
30 x 4		
37 x 4		
45 x 4		
55 x 4		

Figure 4.9 DELTA-WYE Diagram

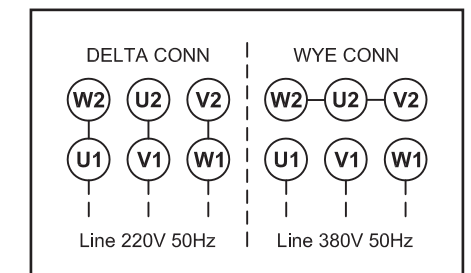
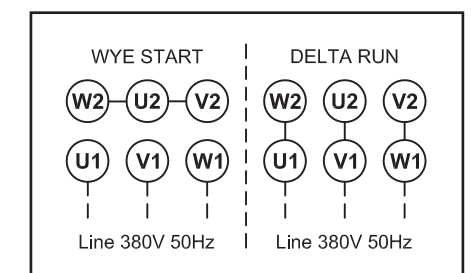

Figure 4.10 WYE-Start DELTA-Run Diagram



Motor Thermal Rating for Cyclic Applications

Table 4.23 Motor Thermal Rating Table

Motor Power HP (kW)	Allowable C x Z				Motor Inertia lb-in ² (kg-m ²)	
	below 35% ED ^[1]	35% ~ 50% ED ^[1]	50% ~ 80% ED ^[1]	80% ~ 100% ED ^[1]	Standard	with Brake
1/8 (0.1)	3200	3000	2000	1200	1.11 (0.000325)	1.2 (0.00035)
1/4 (0.2)	2200	2800	2800	2500	1.71 (0.0005)	1.88 (0.00055)
1/3 (0.25)	2200	2800	2800	2500	1.71 (0.0005)	1.88 (0.00055)
1/2 (0.4)	1800	2200	1500	1500	2.22 (0.00065)	2.31 (0.000675)
3/4 (0.55)	1800	2200	1500	1500	3.45 (0.00101)	3.79 (0.00111)
1 (0.75)	1400	1400	800	500	8.03 (0.00235)	8.82 (0.00258)
1.5 (1.1)	1400	1400	800	500	11.5 (0.00337)	13.5 (0.00396)
2 (1.5)	1200	1200	500	400	13.4 (0.00391)	15.4 (0.0045)
3 (2.2)	1000	900	400	200	30.1 (0.0088)	33.4 (0.00978)
5 (3.7)	800	800	800	700	66.3 (0.0194)	71.4 (0.0209)
7.5 (5.5)	300	300	200	150	99.4 (0.0291)	105 (0.0306)
10 (7.5)	400	350	300	300	140 (0.0409)	154 (0.045)
15 (11)	200	200	150	150	192 (0.0561)	206 (0.0602)
20 (15)	100	90	78	68	340 (0.0995)	393 (0.115)
25 (18.5)	75	65	55	50	875 (0.256)	926 (0.271)
30 (22)	75	65	55	50	875 (0.256)	926 (0.271)
40 (30)	55	40	17	10	1110 (0.326)	1170 (0.342)

Note: [1] % ED = Duty Cycle.

The calculated C x Z value (steps 1 – 3 outlined below) should be less than the allowable value listed in Motor Thermal Rating table above.

1. Obtain the C value:

$$C = \frac{I_M + I_L}{I_M}$$

I_M = Moment of Inertia of the Motor.
 I_L = Moment of Inertia of the Load as seen from the motor shaft.

2. Obtain the Z value (number of starts per hour):

(a) Assume that one operating period consists of “on-time” t_a (sec.), “off-time” t_b (sec.) and the motor is started nr (times/cycle).

$$Z_r = \frac{3600 \cdot nr}{t_a + t_b} \text{ (times/hour)}$$

(b) When inching, ni (times/cycle) is included in 1 cycling (t_a+t_b), the number of inching times per hour Z_i , is then included in the number of starts.

$$Z_i = \frac{3600 \cdot ni}{t_a + t_b} \text{ (times/hour)}$$

(c) Calculate Z by adding Z_r to Z_i by the following formula.

$$Z = Z_r + \frac{1}{2} \cdot Z_i = \frac{3600}{t_a + t_b} \cdot \left(nr + \frac{1}{2} ni \right) \text{ (times/hour)}$$

3. Calculate C x Z (the product of C and Z)

Use the value of C obtained in Step (1) and value of Z obtained in Step (2).

4. Obtain the duty cycle %ED and compare calculated C x Z in the appropriate column from Motor Thermal Rating Table.

$$\%ED = \frac{t_a}{t_a + t_b} \cdot 100$$

t_a = on-time
 t_b = off-time

Brakemotor Characteristics

The brakemotor on Cyclo® gearmotors operates with direct current supplied by a dual voltage rectifier for 230/460V, or single voltage rectifier/power module for other noted voltages. Rectifier or power module is mounted in the motor conduit box.

When used for outdoor installations, standard brakemotor must be protected by a cover. Such covers are available from the factory, please inquire when ordering.

Note: Advise the factory when ordering if you require brake torque greater or lesser than those shown as standard in the Brakemotor Characteristics table below.

Brake Characteristics

Table 4.24 Brake Characteristics - Standard torque, Delay Time, Work Capacity

Brake Model	Motor Capacity		Standard Braking Torque ft - lbs (N - m)	Braking Delay Time (sec)			Brake Work Capacity		
				Normal Braking Action		Fast Braking Action	Allowable E ₀ (J/min)	Gap Adjust (x 10 ⁷ J)	Total E ₁ (x 10 ⁷ J)
	HP x 4P	kW x 4P	Standard Wiring	Inverter Wiring ^[2]					
FB-01A	1/8	0.1	0.7 (1.0)	0.15 ~ 0.2	0.08 ~ 0.12	0.015 ~ 0.02	1080	2.6	6.7
FB-02A	1/8 ~ 1/3	0.1 ~ 0.25	1.4 (2.0)						
FB-05A	1/4 ~ 1/2	0.2 ~ 0.4	2.9 (4.0)	0.1 ~ 0.15	0.03 ~ 0.07	0.01 ~ 0.015	1620	7.0	33.1
FB-1D	1/2	0.4	5.8 (7.5)	0.2 ~ 0.3	0.1 ~ 0.15	0.01 ~ 0.02			
FB-2D	3/4	0.55	11 (15)						
FB-3D	3/4	0.55	16 (22)	0.3 ~ 0.4	0.15 ~ 0.2	0.01 ~ 0.03	3360	16.4	53.7
FB-1E	1	0.75	5.5 (7.5)	0.25 ~ 0.45	0.15 ~ 0.25		2580	11.6	38.7
FB-1HE	1.5	1.1	8.0 (11)	0.45 ~ 0.65	0.25 ~ 0.35	0.01 ~ 0.03	3360	20.8	46.3
FB-2E	2	1.5	11 (15)	0.35 ~ 0.55	0.15 ~ 0.25				
FB-3E	3	2.2	16 (22)	0.75 ~ 0.95	0.4 ~ 0.5	0.02 ~ 0.04	5720	26.3	105.3
FB-5E	5	3.7	30 (40)	1.1 ~ 1.3	0.4 ~ 0.5		6900	57.4	382.8
FB-8E	7.5	5.5	40 (55)	1.0 ~ 1.2	0.3 ~ 0.4	0.02 ~ 0.04	10800	110.2	551.1
FB-10E	10	7.5	59 (80)	1.8 ~ 2.0	0.6 ~ 0.7				
FB-15E	15	11	80 (110)	1.6 ~ 1.8	0.5 ~ 0.6	0.06 ~ 0.14 ^[3]	22440	191.6	1150
FB-20	20	15	110 (150)	-	-				
FB-30	25	18.5	140 (190)	-	-	0.03 ~ 0.11 ^[3]	30672	52	267
	30	22	160 (220)						
	40	30	150 (200)						
ESB-250 ^[2]	50	37	200 (266)	-	-	0.065	30672	52	267
	60	45	235 (320)						

Notes: [1] Also applies to wiring where brake is powered separately from the motor leads.

[2] Available only with power module rated for use at 200VAC or 220VAC.

Above table applies to standard brake specification under standard brake torque. Special brakes may perform differently from those shown. Initial brake torque may be lower than specified brake torque.

If this is the case, under light load start and stop the motor to wear-in the braking surface.

To improve performance for positioning accuracy or lifting applications, consider using fast braking action circuit.

If the brake is operated at a rate greater than the Allowable Brake Work Capacity, E₀,

the brake performance may degrade or become inoperable.

ESB Type brake uses a power module (HD-110M3) that is installed separately from the brakemotor.

ESB Type brake cannot be operated in a vertical orientation.

[3] Values shown for 200V Class and 400V Class Brakes. Please consult factory for 575V Brakes.

Technical Information

Technical Information

Brakemotor Characteristics

Table 4.25 Brake Maintenance - Brake Gap, Brake Lining Thickness

Brake Model	Brake Gap			Brake Lining Thickness	
	Spec. (Initial) inch (mm)	Limit inch (mm)	Adjustment Method	Spec. (Initial) inch (mm)	Limit inch (mm)
FB-01A	0.008 ~ 0.014 (0.2 ~ 0.35)	0.020 (0.5)	Twist detent	0.276 (7.0)	0.256 (6.5)
FB-02A					
FB-05A					
FB-1D	0.012 ~ 0.016 (0.3 ~ 0.4)	0.024 (0.60)	Shim	0.347 (8.8)	0.307 (7.8)
FB-2D					
FB-3D					
FB-1E	0.010 ~ 0.014 (0.25 ~ 0.35)	0.024 (0.60)	Shim	0.347 (8.8)	0.307 (7.8)
FB-1HE					
FB-2E					
FB-3E	0.014 ~ 0.018 (0.35 ~ 0.45)	0.034 (0.85)	Nut	0.410 (10.4)	0.331 (8.4)
FB-5E					
FB-8E					
FB-10E	0.024 ~ 0.028 (0.6 ~ 0.7)	0.047 (1.2)	Nut	0.433 (11.0)	0.276 (7.0)
FB-15E					
FB-20					
FB-30	0.024 ~ 0.028 (0.6 ~ 0.7)	0.059 (1.5)	Threaded Ring	0.630 (16.0)	0.472 (12.0)
ESB-250 ^[2]					

Notes: [1] Also applies to wiring where brake is powered separately from the motor leads.

[2] Available only with power module rated for use at 200VAC or 220VAC.

Above table applies to standard brake specification under standard brake torque. Special brakes may perform differently from those shown.

Initial brake torque may be lower than specified brake torque.

If this is the case, under light load start and stop the motor to wear-in the braking surface.

To improve performance for positioning accuracy or lifting applications, consider using fast braking action circuit.

If the brake is operated at a rate greater than the Allowable Brake Work Capacity, E0,

the brake performance may degrade or become inoperable.

ESB Type brake uses a power module (HD-110M3) that is installed separately from the brakemotor.

ESB Type brake cannot be operated in a vertical orientation.

[3] Values shown for 200V Class and 400V Class Brakes. Please consult factory for 575V Brakes.

Brakemotor: Brake Current Rating

Table 4.26a Brake Current for Standard Fractional Motor and AF-Motor (AV)

Brake Model	230VAC, 50/60Hz			460VAC, 50/60Hz			575VAC, 50/60Hz		
	Vdc (V)	Idc (A)	Iac (A)	Vdc (V)	Idc (A)	Iac (A)	Vdc (V)	Idc (A)	Iac (A)
FB-01A	207VDC Full Wave	0.05	0.06	207VDC Half Wave	0.05	0.04	259VDC Half Wave	0.05	0.03
FB-02A		0.08	0.1		0.08	0.06		0.09	0.07
FB-05A		0.1	0.1		0.1	0.1		0.1	0.1
FB-1D		0.2	0.2		0.2	0.2		0.2	0.2
FB-2D									
FB-3D									

Table 4.26b Brake Current for EP.NA Motor

Brake Model	230VAC, 50/60Hz			240VAC, 50/60Hz			460VAC, 50/60Hz			480VAC, 50/60Hz						
	Vdc (V)	Idc (A)	Iac (A)	Vdc (V)	Idc (A)	Iac (A)	Vdc (V)	Idc (A)	Iac (A)	Vdc (V)	Idc (A)	Iac (A)				
FB-1E	207VDC Full Wave	0.1	0.1	216VDC Full Wave	0.1	0.1	207VDC Half Wave	0.1	0.1	216VDC Half Wave	0.1	0.1				
FB-1HE		0.2	0.2		0.2	0.2		0.2	0.2							
FB-2E		0.2	0.2		0.2	0.2		0.2	0.2							
FB-3E		0.4	0.4		0.4	0.4		0.4	0.4							
FB-5E		0.4	0.4		0.5	0.5		0.4	0.3							
FB-8E																
FB-10E																
FB-15E																
FB-20		207VDC	2.0/1.0 ^[3]		2.0/0.8 ^[3]	216VDC		2.1/1.1 ^[3]	2.1/0.8 ^[3]		414VDC	1.0/0.5 ^[3]	1.0/0.4 ^[3]	432VDC	1.0/0.5 ^[3]	1.0/0.4 ^[3]
FB-30		/104VDC Module ^[2]				/108VDC Module ^[2]					/207VDC Module ^[2]			/216VDC Module ^[2]		
ESB-250 ^[1]																

Table 4.26b continued... Brake Current for EP.NA Motor

Brake Model	575VAC, 50/60Hz		
	Vdc (V)	Idc (A)	Iac (A)
FB-1E	259VDC Half Wave	0.1	0.1
FB-1HE		0.2	0.2
FB-2E		0.2	0.2
FB-3E		0.4	0.3
FB-5E		0.5	0.4
FB-8E			
FB-10E			
FB-15E	259VDC	0.4	0.3
FB-20	Half Wave		
FB-30			
ESB-250 ^[1]			

Notes: [1] ESB-250 is available only with power module rated for use at 200VAC or 220VAC.

[2] Power module type brake control generates two voltage levels--1) high excitation voltage for initial release, and 2) lower holding voltage.

[3] 2 brake current values shown corresponding to the two voltage levels from power module--1) excitation current on initial power up, and 2) holding current.

Brake coil design will be specific to brake voltage specified at time of order. Check motor nameplate, to determine brake voltage rating.

FB-20 and FB-30 Brake Coil and Power Module come in two voltage ranges--1) 200-240VAC, and 2) 380-480VAC.

Brakemotor: Brake Current Rating

Table 4.27a Brake Current for Fractional Motor CE Motor

Brake Model	220VAC, 50/60Hz			230VAC, 50/60Hz			380VAC, 50/60Hz			400VAC, 50/60Hz		
	Vdc (V)	Idc (A)	Iac (A)	Vdc (V)	Idc (A)	Iac (A)	Vdc (V)	Idc (A)	Iac (A)	Vdc (V)	Idc (A)	Iac (A)
FB-01A	99VDC Half Wave	0.13	0.12	104VDC Half Wave	0.13	0.12	171VDC Half Wave	0.06	0.04	180VDC Half Wave	0.06	0.04
FB-02A		0.2	0.2		0.2	0.2		0.08	0.07		0.08	0.07
FB-05A		0.3	0.2		0.2	0.2		0.1	0.1		0.1	0.1
FB-1D												

Table 4.27b Combination Table with Brakemotor Inertia

Brake Model	Motor Frame Sizes	Inertia WR2 lb-in2 (kg-m2)
FB-1E	N-80M	8.82 (0.00258)
FB-1HE	N-90S	13.5 (0.00396)
FB-2E	N-90L	15.4 (0.0045)
FB-3E	N-100L	33.4 (0.00978)
FB-5E	N-112M	71.4 (0.0209)
FB-8E	N-132S	105 (0.0306)
FB-10E	N-132M	154 (0.045)
FB-15E	N-160M	206 (0.0602)
FB-20	N-160L	393 (0.115)
FB-30	N-180MS	926 (0.271)
	N-180M	926 (0.271)
FB-30	N-180L	1170 (0.342)
ESB-250	N-200L	1380 (0.404)
	N-200LL	2550 (0.745)

Table 4.27c Brake Current for CE Motor

Brake Model	220VAC, 50/60Hz			230VAC, 50/60Hz			380VAC, 50/60Hz			400VAC, 50/60Hz		
	Vdc (V)	Idc (A)	Iac (A)	Vdc (V)	Idc (A)	Iac (A)	Vdc (V)	Idc (A)	Iac (A)	Vdc (V)	Idc (A)	Iac (A)
FB-01A	99VDC Half Wave	0.13	0.12	104VDC Half Wave	0.13	0.12	171VDC Half Wave	0.06	0.04	180VDC Half Wave	0.06	0.04
FB-02A		0.2	0.2		0.2	0.2		0.08	0.07		0.08	0.07
FB-05A		0.3	0.2		0.2	0.2		0.1	0.1		0.1	0.1
FB-1D												
FB-1E		0.2	0.2		0.2	0.2		0.2	0.2		0.2	0.2
FB-1HE		0.5	0.4		0.5	0.4		0.5	0.4		0.5	0.4
FB-2E		0.6	0.5		0.6	0.5		0.6	0.5		0.6	0.5
FB-3E		1	0.7		1	0.8		1	0.8		1	0.8
FB-4E		1.1	0.9		1.2	0.9		0.5	0.4		0.5	0.4
FB-5E												
FB-8E												
FB-10E												
FB-15E												
FB-20		198VDC /99VDC Module ^[2]	2.0/1.0 ^[3]		2.0/0.8 ^[3]	207VDC /104VDC Module ^[2]		2.0/1.0 ^[3]	2.0/0.8 ^[3]		342VDC /171VDC Module ^[2]	0.8/0.4 ^[3]
FB-30												
ESB-250 ^[1]	2.2/1.1 ^[3]		2.2/0.9 ^[3]									

Notes: [1] ESB-250 is available only with power module rated for use at 200VAC or 220VAC.

[2] Power module type brake control generates two voltage levels--1) high excitation voltage for initial release, and 2) lower holding voltage.

[3] 2 brake current values shown corresponding to the two voltage levels from power module--1) excitation current on initial power up, and 2) holding current.

Brake coil design will be specific to brake voltage specified at time of order. Check motor nameplate, to determine brake voltage rating.

FB-20 and FB-30 Brake Coil and Power Module come in two voltage ranges--1) 200-240VAC, and 2) 380-480VAC.

Brakemotor: Optional Brake Torques

Table 4.28 Standard Brake Models

Brake Model	Motor Capacity		Braking Torque ft-lbs (N-m)	
	HP x 4P	kW x 4P	Standard	Optional
FB-01A	1/8	0.1	0.7 (1.0)	0.25 (0.34), 0.3 (0.4), 0.4 (0.54), 0.48 (0.65), 0.6 (0.8), 0.7 (1.0), 1.0 (1.4)
FB-02A	1/8 ~ 1/3	0.1 ~ 0.25	1.4 (2.0)	0.48 (0.65), 0.6 (0.8), 0.7 (1.0), 1.0 (1.4), 1.4 (2.0), 1.9 (2.6), 2.3 (3.1)
FB-05A	1/4 ~ 1/2	0.2 ~ 0.4	2.9 (4.0)	0.7 (1.0), 1.0 (1.4), 1.4 (2.0), 1.9 (2.6), 2.3 (3.1)
FB-1D	1/2	0.4	5.8 (7.5)	1.9 (2.6), 2.3 (3.1), 2.7 (3.7), 3.9 (5.3), 4.6 (6.2), 6.9 (9.4), 7.7 (10)
FB-2D	3/4	0.55	11 (15)	3.6 (4.9), 4.3 (5.8), 5.1 (6.9), 7.2 (9.8), 8.7 (12), 13 (18), 14 (19)
FB-3D	3/4	0.55	16 (22)	5.3 (7.2), 6.6 (9.0), 7.4 (10), 11 (15), 13 (18), 19 (26), 21 (28)
FB-1E	1	0.75	5.5 (7.5)	7.4 (10), 4.0 (5.5), 3.0 (4.0), 2.2 (3.0)
FB-1HE	1.5	1.1	8.0 (11)	11 (15), 5.5 (7.5), 3.7 (5.0), 2.2 (3.0)
FB-2E	2	1.5	11 (15)	15 (20), 8.0 (11), 5.5 (7.5), 3.7 (5.0)
FB-3E	3	2.2	16 (22)	22 (30), 11 (15), 7.4 (10), 4.4 (6.0)
FB-4E	4	3.0	22 (30)	30 (40), 16 (22), 11 (15), 7.4 (10)
FB-5E	5	3.7	30 (40)	40 (55), 22 (30), 15 (20), 7.4 (10)
FB-8E	7.5	5.5	40 (55)	53 (72), 30 (40), 22 (30), 15 (20)
FB-10E	10	7.5	59 (80)	80 (110), 44 (60), 30 (40), 15 (20)
FB-15E	15	11	80 (110)	110 (150), 59 (80), 44 (60), 29 (40)
FB-20	20	15	110 (150)	160 (220), 130 (175), 89 (120), 74 (100), 63 (85), 44 (60)
FB-30	25	18.5	140 (190)	160 (220), 110 (150), 89 (120), 74 (100), 44 (60)
	30	22	160 (220)	130 (175), 110 (150), 89 (120), 63 (85)
	40	30	150 (200)	120 (160), 74 (100)
ESB-250	50	37	195 (266)	275 (372), 235 (320), 155 (212), 120 (160), 78 (106)
	60	45	235 (320)	315 (426), 275 (372), 195(266), 155 (212), 120 (160)

Motor continued

Brakemotor Standard Wiring Connection

Models FB-01A through FB-15E, 230/460V, 60Hz or 575V, 60Hz

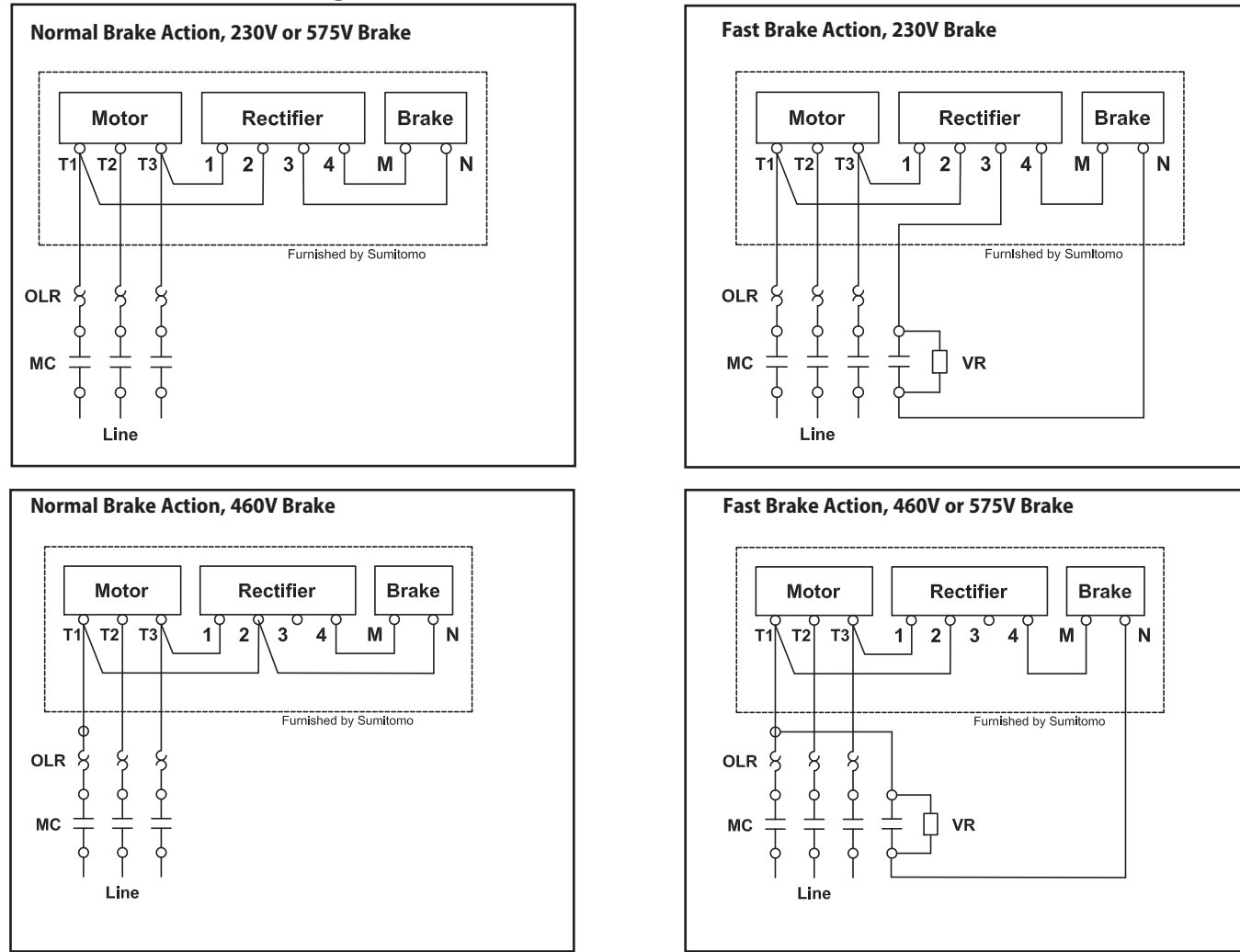

Key:
MC: Electromagnetic Relay
OLR: Overload or Thermal Relay
VR: Varistor (protective device, refer to Varistor Specification Table)

Brakemotor Standard Wiring Connection

Table 4.29 Varistor Specification Table

Operating Voltage		190-230V	380-460V	575V
Varistor Rated Voltage		AC260-300V	AC510V	AC604V
Varistor Voltage		430-470V	820V	1000V
Rated Watt	FB-01A, 02A, 05A	Over 0.4W	Over 0.4W	Over 0.4W
	FB-1E, 1D	Over 0.6W	Over 0.6W	Over 0.4W
	FB-1HE, 2E, 2D, 3D	Over 1.5W	Over 1.5W	Over 0.6W
	FB-3E, 4E	Over 1.5W	Over 1.5W	Over 0.6W
	FB-5E, 8E	Over 1.5W	Over 1.5W	Over 1.5W
	FB-10E, 8E	Over 1.5W	Over 1.5W	Over 1.5W
	FB-20, 30			Over 1.5W

Motor continued

Brakemotor Inverter Wiring Connection

Models FB-01A through FB-15E, 230/460V, 60Hz or 575V, 60Hz

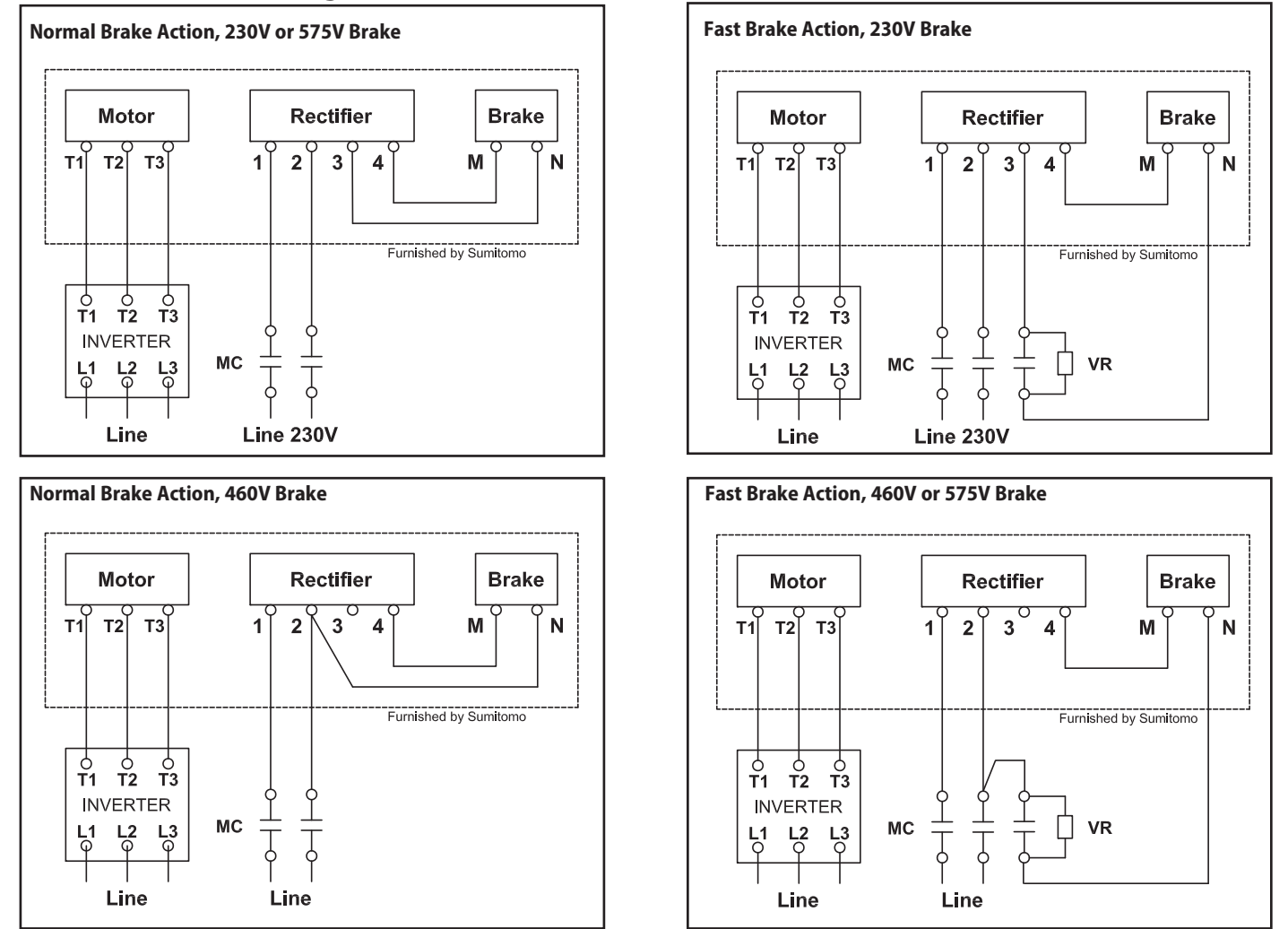

Key:
MC: Electromagnetic Relay
OLR: Overload or Thermal Relay
VR: Varistor (protective device, refer to Varistor Specification Table)

Brakemotor Inverter Wiring Connection, EP.NA Motor

Table 4.30 Varistor Specification Table

Operating Voltage		190-230V	380-460V	575V
Varistor Rated Voltage		AC260-300V	AC510V	AC604V
Varistor Voltage		430-470V	820V	1000V
Rated Watt	FB-01A, 02A, 05A	Over 0.4W	Over 0.4W	Over 0.4W
	FB-1E, 1D	Over 0.6W	Over 0.6W	Over 0.4W
	FB-1HE, 2E, 2D, 3D	Over 1.5W	Over 1.5W	Over 0.6W
	FB-3E, 4E	Over 1.5W	Over 1.5W	Over 0.6W
	FB-5E, 8E	Over 1.5W	Over 1.5W	Over 1.5W
	FB-10E, 8E	Over 1.5W	Over 1.5W	Over 1.5W
	FB-20, 30			Over 1.5W

Standard Wiring Connection for CE Motors

Models FB-01A through FB-5E, 220/380V, 50Hz

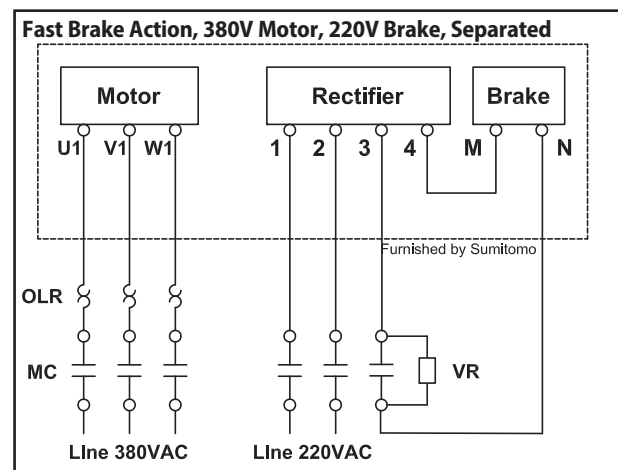
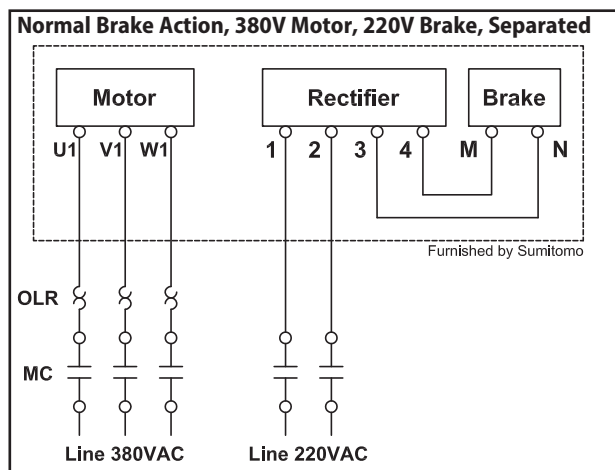
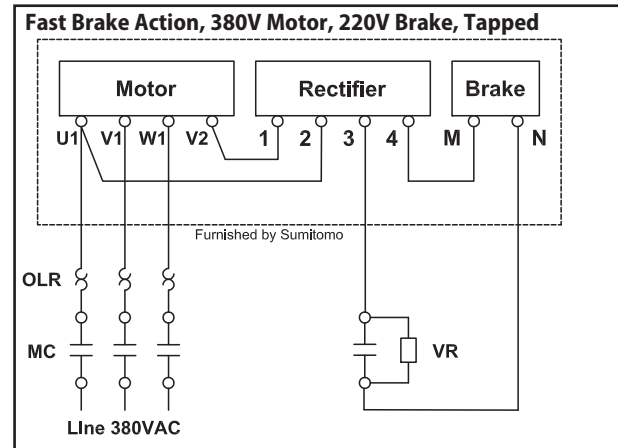
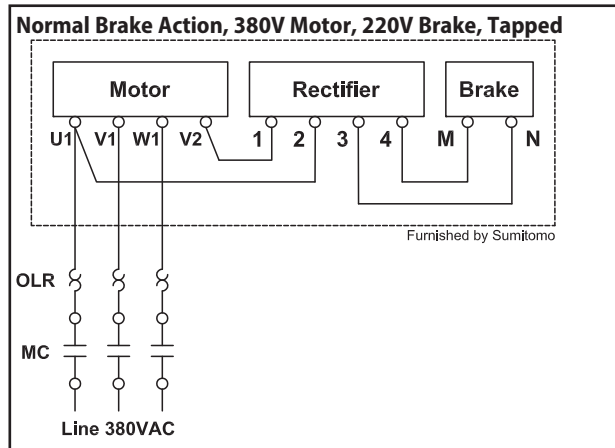
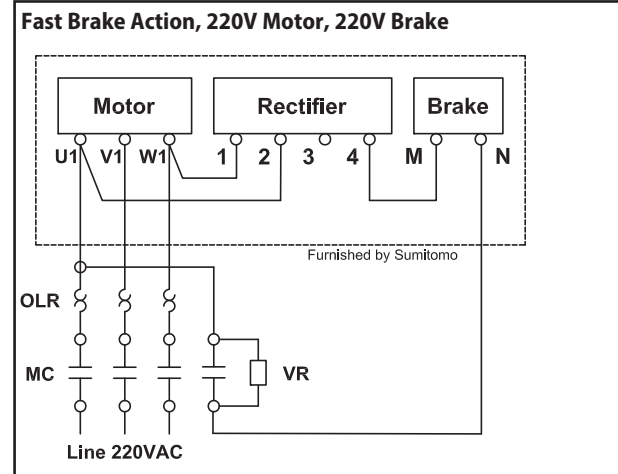
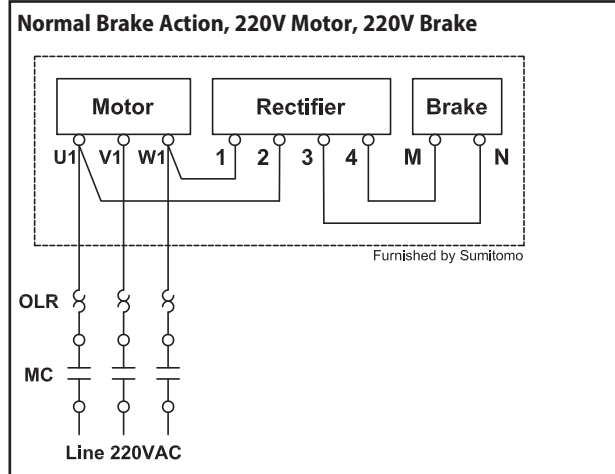

Key:
MC: Electromagnetic Relay
OLR: Overload or Thermal Relay
MCB: Magnetic Circuit Breaker
VR: Varistor (protective device, refer to Varistor Specification Table)

Standard Wiring Connection for CE Motors (continued)

Models FB-8E through FB-15E, 380V, 50Hz

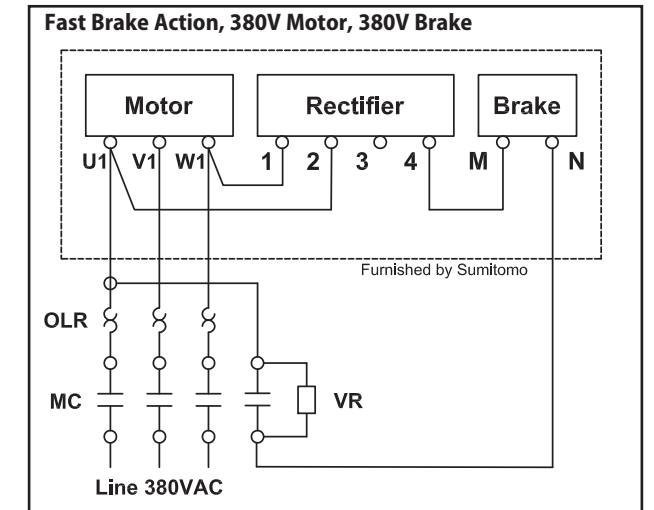
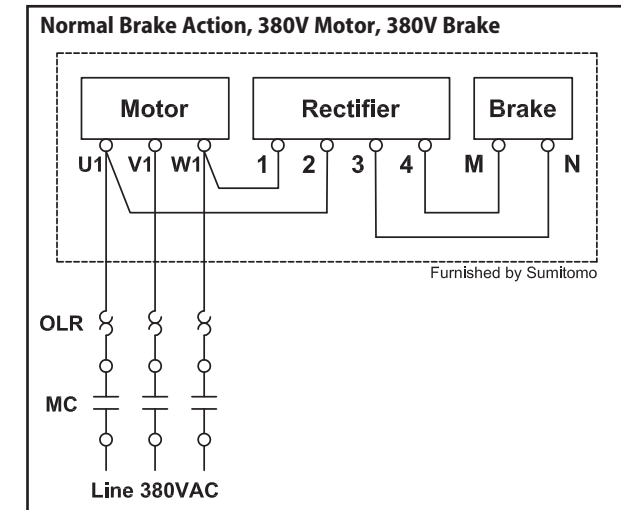

Models FB-01A through FB-15E with Inverter

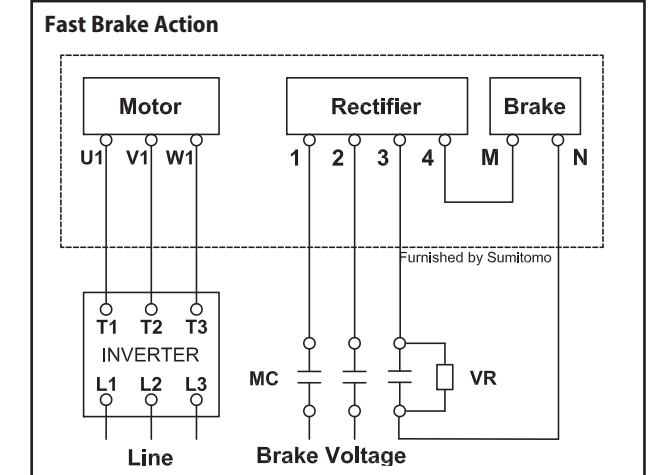
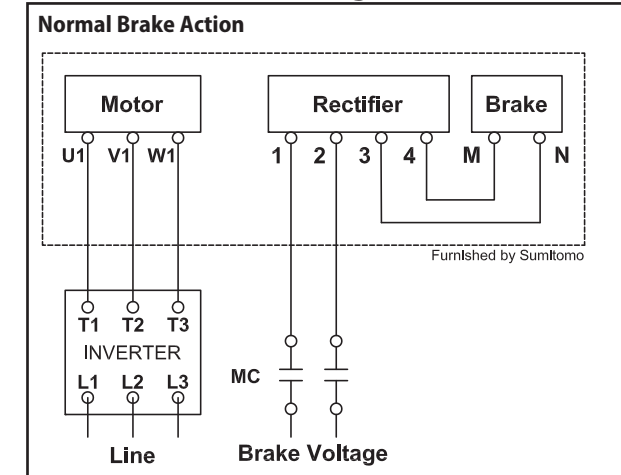

Key:
MC: Electromagnetic Relay **OLR:** Overload or Thermal Relay **MCB:** Magnetic Circuit Breaker
VR: Varistor (protective device, refer to Varistor Specification Table)

Table 4.31a Standard CE Motor, Motor/Brake Voltage Table

Motor Power kW x 4P	Brake Model	Motor Voltage	Brake Voltage
0.1	FB-01A	220/380V, 50Hz	220V, 50Hz*
0.2, 0.25	FB-02A		
0.4	FB-05A		
0.55	FB-1D		
0.75	FB-1E		
1.1	FB-2E		
1.5	FB-1HE		
2.2	FB-3E		
3.0	FB-4E		
3.7	FB-5E		
5.5	FB-8E	380V, 50Hz	380V, 50Hz
7.5	FB-10E		
11	FB-15E		

Table 4.31b Varistor Specification Table

Operating Voltage	190-230V	380-460V	575V
Varistor Rated Voltage	AC260-300V	ACS10V	AC604V
Varistor Voltage	430-470V	820V	1000V
Rated Watt	FB-01A, 02A, 05A	Over 0.4W	Over 0.4W
	FB-1E, 1D	Over 0.6W	Over 0.4W
	FB-1HE, 2E	Over 1.5W	Over 0.6W
	FB-3E, 4E	Over 1.5W	Over 0.6W
	FB-5E, 8E	Over 1.5W	Over 1.5W
	FB-10E, 8E	Over 1.5W	Over 1.5W
	FB-20, 30		Over 1.5W

Technical Information

Technical Information

Wiring for Brake Models FB-20 / FB-30 - EP.NA Motor and IE3 CE Motor

FB-20 and FB-30 Brake Wiring, 480VAC or less

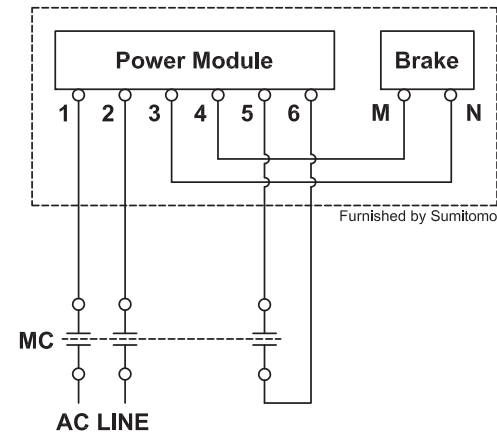

FB-20 and FB-30 Brake Wiring, 575VAC

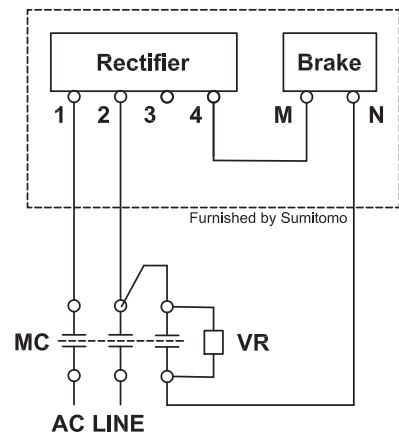

Key:
MC: Electromagnetic Relay
VR: Varistor (protective device, refer to Varistor Specification Table)

Brake Rectifiers and Brake Power Modules

Table 4.32a Brake Rectifiers for EP.NA Motors

Brake Type	Motor Power HP (kW) x P	230V/460V Rectifier		575V Rectifier	
		Model Number	Part Number	Model Number	Part Number
FB-1E	1 x 4	25FW-4FB3	EW107WW-01	10F-6FB3	EW104WW-01
FB-1HE	1.5 x 4				
FB-2E	2 x 4				
FB-3E	3 x 4				
FB-5E	5 x 4				
FB-8E	7.5 x 4				
FB-10E	10 x 4				
FB-15E	15 x 4				
FB-20	20 x 4				
FB-30	25 x 4				
	30 x 4				
	40 x 4				

Table 4.32b Brake Rectifiers for IE3 CE Motors

Brake Type	Motor Power HP (kW) x P	220V Rectifier		380V Rectifier	
		Model Number	Part Number	Model Number	Part Number
FB-1E	0.75 x 4	10F-2FB2	MP983WW-01		
FB-1HE	1.1 x 4				
FB-2E	1.5 x 4				
FB-3E	2.2 x 4				
FB-4E	3.0 x 4				
FB-5E	3.7 x 4 4.0 x 4				
FB-8E	5.5 x 4			05F-4FB2	MP985WW-01
FB-10E	7.5 x 4			15F-4FB1	EW397WW-01
FB-15E	11 x 4				

Table 4.32c Brake Power Modules for EP.NA Motors and IE3 CE Motors

Brake Type	Motor (HP x P)	170 ~ 300VAC Module		380 ~ 480VAC Module	
		Model Numbers	Part Number	Model Numbers	Part Number
FB-20	20 x 4	13SR-2	EY570WW-01	10SR-4	MQ003WW-01
FB-30	25 x 4				
	30 x 4				
	40 x 4				

