

A global power transmission solutions provider, with facilities strategically located throughout the world, providing comprehensive products and services in your region.

FORTRESS® DROP-IN

The Smart Upgrade for Food & Beverages Applications



Canadian Headquarters

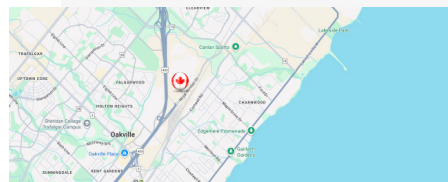

1453 Cornwall Road
Oakville, ON L6J 7T5

Email: smc.customerservice@shi-g.com
Phone: 1-844-SM-CYCLO (762-9256)

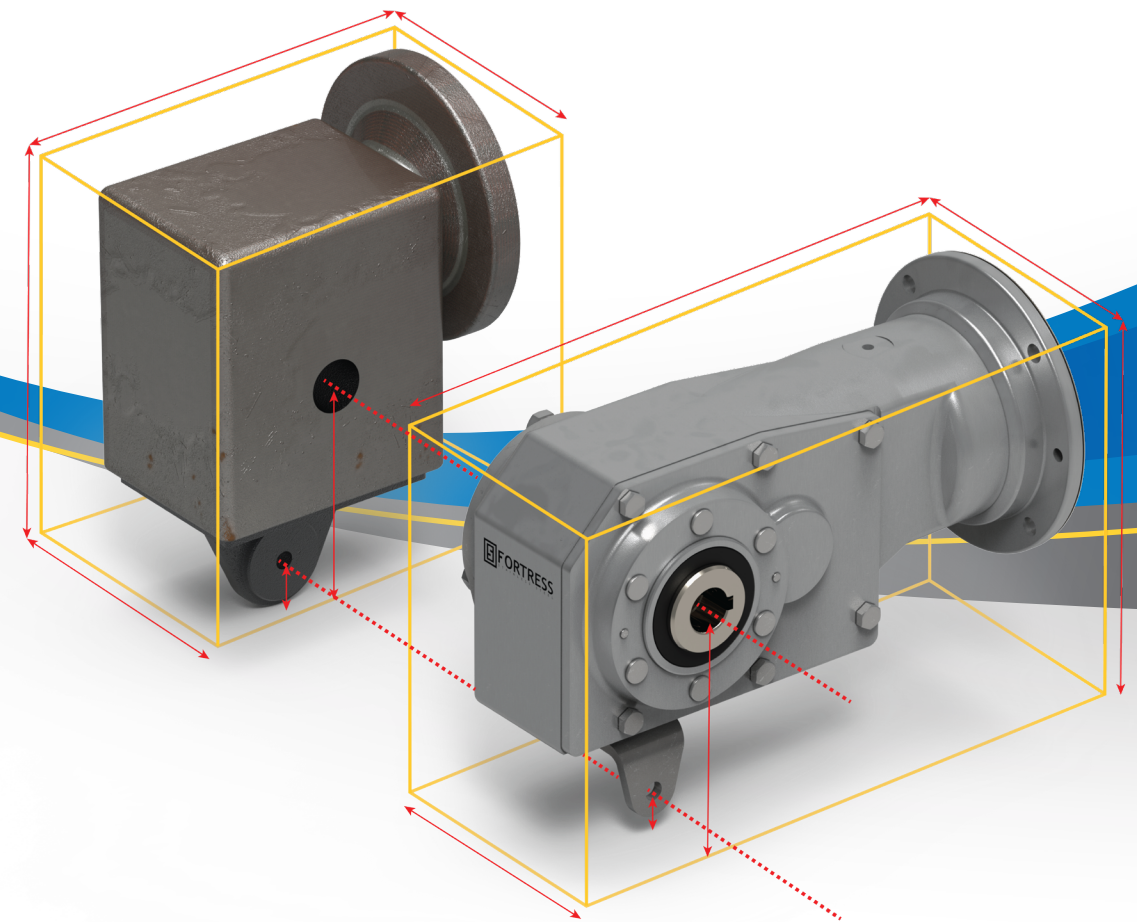

Replace Your Worm Gearbox and Lower Total Ownership Costs by up to 50%

- Food Grade Grease-Lubricated
- Universal Mounting
- 3-year Warranty
- Sealed For Life - No Leaks & Maintenance Free
- Hypoid Gearing
- IP69K Rated

Direct Replacement of the Leading Competitor Gearboxes Without Redesign

Competitor's gearbox with CD 50 mm **Fortress® S320**

Competitor's gearbox with CD 63 mm **Fortress® S420**

Depending on the application and ratio, you may be able to downsize – reducing costs even further.



- Torque arm bracket to match existing mount location.
- Output shaft center line for easy alignment.
- Foot-mount base to match existing bolt pattern for fast replacement.

3-5 Day Shipping on Standard Packages

Need it sooner? Contact us!

For more product information scan this QR code ▶



Engineered for Superior Performance & CFIA Compliance

See how Fortress® outperforms traditional worm gearboxes in efficiency, torque output, and operating temperature – keeping your line running stronger and longer.

High Gearbox Efficiency

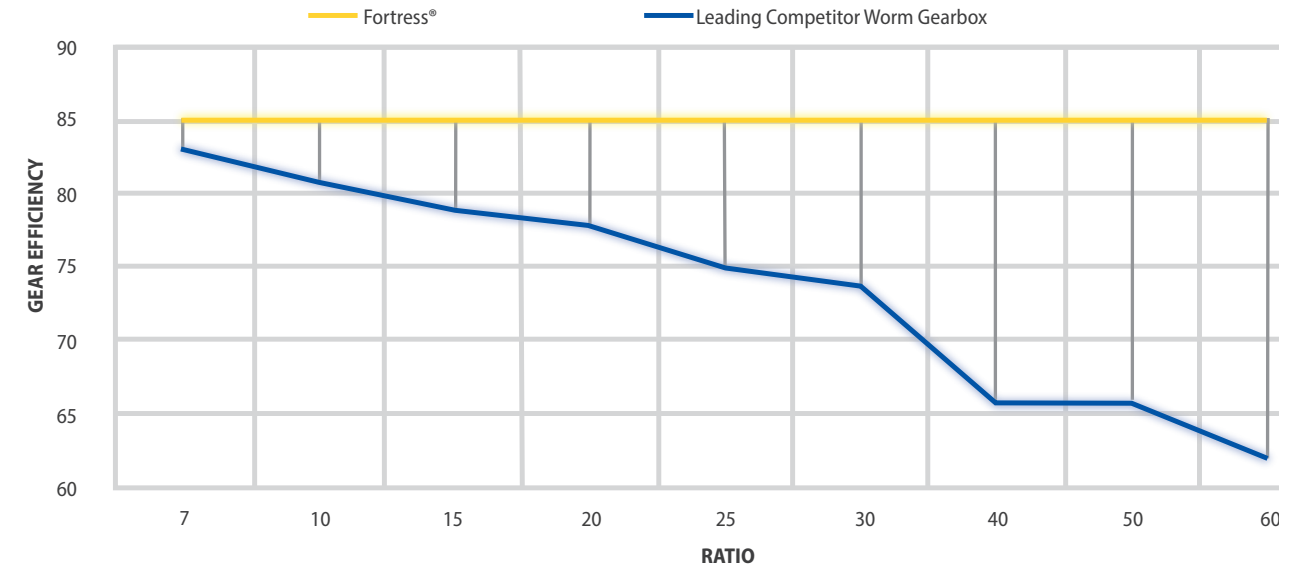

Fortress® maintains 85% efficiency across all ratios

More Torque Output

- The output torque based on ¾ HP at 60:1 ratio 29 RPM output:

Leading Competitor Worm Gearbox 1,005 in-lbs **Fortress® S420** 1,386 in-lbs

Fortress® delivers 37% more output torque on average compared to leading worm gearbox manufacturers .

Cooler Operation

- Worm gearboxes generate excess heat, reducing the life of oil, seals, and bearings. Fortress® stays cooler with hypoid gearing, extending performance and reliability.

