

Quick Start Guide

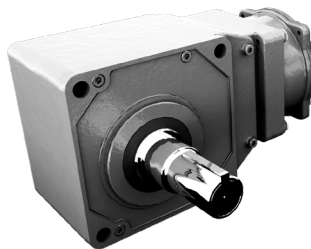
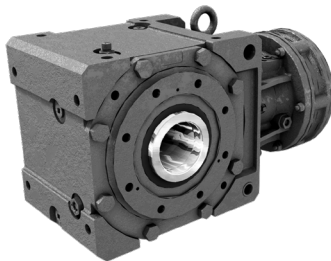

Cyclo[®], BBB4, BBB5, BBBH, HBB, Hyponic[®]

Gearmotor Quick Start Guide

Contents

Safety Precautions.....	1
Inspection of the Nameplate.....	2
Installation	2
Foot Mount - Mounting and Alignment.....	4
Keyed Hollow Bore.....	5
Shrink Disc.....	6
Taper-Grip® Bushing	8
Turnbuckle Torque Arm.....	13
Tie Rod Torque Arm.....	15
T-Type Torque Arm	19
Banjo Type Torque Arm	21
Flange Mount	23
Motor.....	23
Lubrication	25
Oil Supply Procedures	25
Hyponic® and BBBH	26
Cyclo® 6000, HBB, BBB4 and BBB5	26
BBB4 and BBB5 in the Y4 Position	30
HBB Oil Fill Quantities.....	36
Start-Up.....	36
Long Term Storage Procedure	37

Safety Precautions

Review and adhere to the instructions in this manual to:

- ensure trouble-free operation
- protect your rights to make a warranty claim

Read this manual and all accompanying documents thoroughly before use. Understand the machine, information on safety, and all precautions for correct operation. Sumitomo recommends that this manual is easily accessible for reference at the machine location.



- **Only properly trained personnel** should transport, install, align, wire, inspect, operate, and maintain the unit.
- The user should install secondary safety devices for applications involving passenger transportation or elevators. **Failure to do so may result in personnel injury, death, and/or equipment damage.**
- Be sure to **install and operate speed reducers and gearmotors in compliance with applicable local and national safety codes.** Appropriate guards for rotating shafts are available from factory.

CAUTION:



- Operate the unit only within its design and performance specifications; otherwise, injury or damage to the system may occur.
- Keep hands and all foreign objects from the internal moving parts of the unit; otherwise, injury or damage to the system may occur.
- Take damaged units off-line immediately and do not resume operation until properly repaired.
- Modifications or alterations of any kind to the unit will void the warranty and all subsequent claims.
- Consult the factory if speed reducers are driven by DC motors, powered by variable frequency AC drives, or operated at a speed in excess of standard catalog input speeds.

Inspection Upon Delivery

In order to avoid injury, ensure that the unit is in a stable position before unpacking.

- **Verify that the unit received matches your order.** Using the incorrect product may cause equipment damage or personnel injury.
- **Do not** remove the nameplate from the unit.

Upon delivery, inspect the unit for damage that may have occurred during shipment. Notify the shipping company immediately if you find any damage. **Do not** install or operate a damaged unit.

Upon receipt of the reducer/gearmotor, verify that:

- the model number on the unit nameplate matches the purchase order
- the unit was not damaged during shipping

Please consult your Sumitomo agent, distributor, or sales office if you find any defects not attributable to shipping damage, or if you have any questions.

Inspection of the Nameplate

When contacting Sumitomo agent, distributor, or sales office about this product, please be prepared to provide the following information from the reducer/gearmotor nameplate:

- reducer or gearmotor model number (nomenclature)
- reduction ratio
- serial number

Installation



- Do not use the reducer/gearmotor for specifications other than those shown on the nameplate or in the manufacturing specification documents. Personnel injury and/or equipment damage may occur.
- Do not place combustible material on or around the unit; fire may occur.
- Do not place any objects around the unit that will prohibit proper ventilation. Inadequate ventilation may lead to high unit temperature and/or fire.
- Do not step on or hang from the unit. Excessive weight may cause component breakage leading to personal injury and/or equipment damage.
- Do not touch the shaft, keyway, or motor fan with bare hands; injury may occur.
- For applications in which lubricant leaks could adversely affect operations (i.e., package handling, food processing), place an oil pan below the unit to protect against contamination that may occur if oil seals become damaged or worn.
- Do not remove the eye-bolt from the motor, should you need to remove the eye-bolt for any reason, install a replacement bolt in the tapped hole to prevent water from entering the motor.

Installation Conditions

Standard Ambient Temperature Range:	14° - 104°F (-10° - 40°C)
Ambient Humidity:	85% or less
Altitude:	3,280 feet (1,000 m) or less
Atmosphere:	The location should not contain corrosive gas, explosive gas, or steam. The location should be free of dust and well ventilated.
Location:	Indoor – free of dust and water

Consult Sumitomo when the unit will operate in conditions other than those specified above. Special unit modifications may be required.

Units manufactured according to customer specified application requirements (i.e. outdoor modifications, high-temperature modifications) are designed to operate within the specified environment.

Operation After Storage

Before operating the unit after an extended storage period, ensure that non-metal parts, i.e., oil seals, o-rings, air breather, have not deteriorated. Non-metal parts may deteriorate easily from exposure to ambient conditions (i.e., extreme temperatures, UV rays). Replace deteriorated parts with new before unit start-up.

After starting the unit, verify that there is no abnormal noise, vibration, and/or temperature rise. Immediately stop the unit and call your local distributor, Original Equipment Manufacturer or Sumitomo directly if you observe any abnormality.

Installation Angle

Mount the unit in the specified position for which it was ordered. Confirm the mounting position from the gearbox nameplate.

Consult your local distributor, Original Equipment Manufacturer or Sumitomo directly if the mounting angle is to be other than horizontal or vertical.

Severe Loading Conditions

For applications with severe vibration and/or frequent starts and stops, Sumitomo recommends the use of high-strength mounting bolts of Grade 10.9 (or greater).

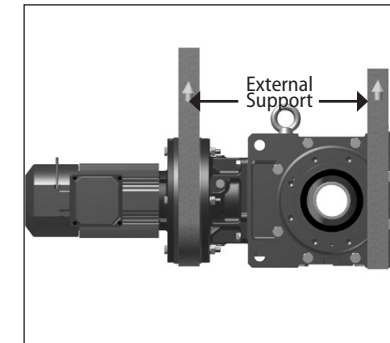

Installation onto the Driven Machine



- Before coupling the reducer/gearmotor to the machine, verify the appropriate/desired rotation of the machine. Differences in the rotational direction may cause personnel injury and/or equipment damage.
- Before operating the unit, ensure that all safety guards around the rotating components are in-place and secure. Failure to do so may result in personal injury.

Foot Mount - Mounting and Alignment

Mounting

- Consult Sumitomo when the unit will operate in conditions other than those specified above. Special unit modifications may be required.
- Install the unit so inspection and/or maintenance procedures may be easily performed. Install all units that are not shaft mounted on a sufficiently rigid base.

Foundations

Foundations must be designed to withstand shock and stress applied from the load side through the reducer.

Secure Housing

When the unit's operating conditions include excessive vibration and/or frequent starts and stops, secure it on the mounting surface by inserting dowel pins into the holes provided in the casing feet. This ensures that bending or shearing forces are reduced on the mounting bolts. Be sure the dowel pins are inserted securely, especially when the unit will be operated under severe, recurrent peak loads.

Accurate Alignment

When the reducer is connected to the motor and driven machine with couplings, the shafts **must** be properly aligned. When the reducer is connected by V-pulleys or sprockets, ensure that the belts or chains are adjusted per manufacturers recommendations.

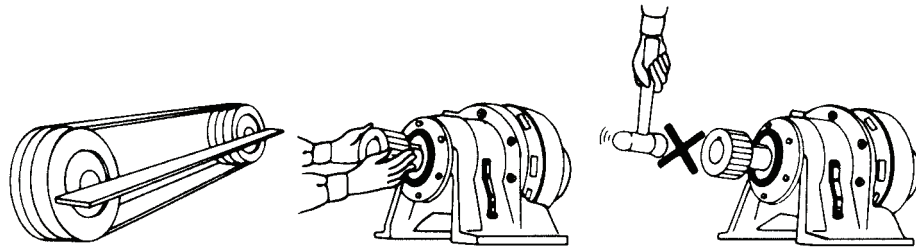

Overhung Load Positions

Overhung loads should be located as close to the reducer housing as possible.

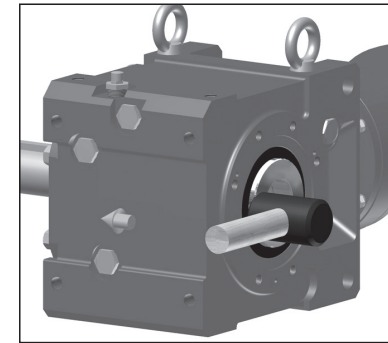
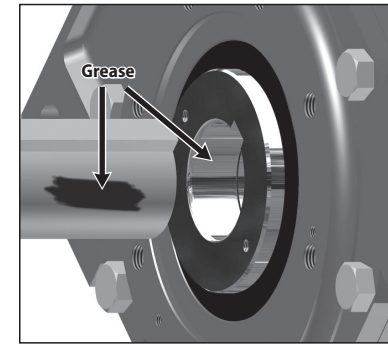
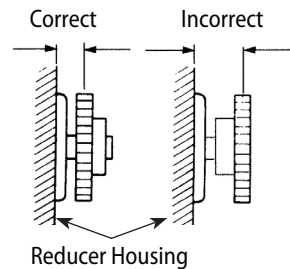

Keyed Hollow Bore

1

Apply molybdenum disulfide grease or similar anti-seize compound, to the driven shaft surface and inside the reducer keyed hollow bore.

2

Align the driven shaft with the reducer/gearmotor bore and carefully slide unit onto the driven shaft.



If the fit is tight, strike on the keyed hollow bore with a soft non-metallic mallet to assist in the assembly.

If using a soft mallet during installation, strike only against the unit's steel keyed hollow bore. Do not strike the reducer housing or oil seal. Damage to the bearings, the housing, and/or the seals may occur.

Note: If the fit is tight, you may use a jig such as the one shown here to ease assembly. **Sumitomo does not supply a mounting jig. This information is provided for reference only.**

Table 1. Jig Dimensions

Size	b	c	Size	b	c
	A2	Bearing		A2	Bearing
5Z	25	51104	1120	15	5110
4A/5A	25	51105	1220	13	5110
4B/5B	25	51105	1320	13	5110
4C/5C	25	51105	1420/30/40	15	51201
4D	35	51107	1520/21/22/30/31/40 HZ522/23/24	14	51202
4E	35	51107	1630/31/32/33/34/40 HA635	25	51204
4F	46	51109			

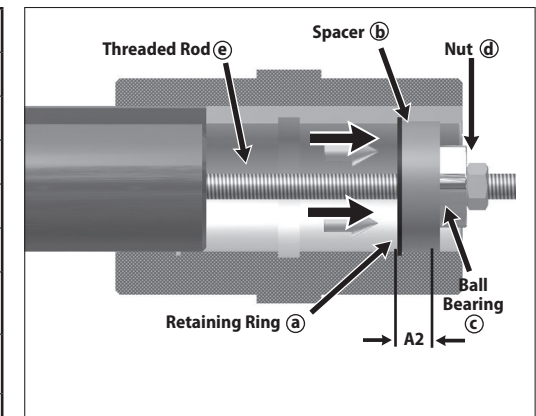

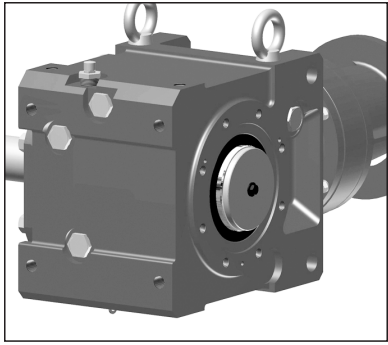

3

Once driven shaft has been completely inserted into the unit's keyed hollow bore, secure the shaft in place using a keeper plate as shown in this example, or some other means of securing the unit to the driven shaft.



Do not operate unit until the torque arm has been attached. Refer to the **Torque Arm Installation** section in this guide for instructions.

Shrink Disc



Before placing unit onto driven shaft, **do not apply grease, oil, or anti-seize grease** to the entire driven shaft or to the bore of the shrink disc. Use of these friction-minimizing products will adversely affect the ability of the unit to transmit torque.

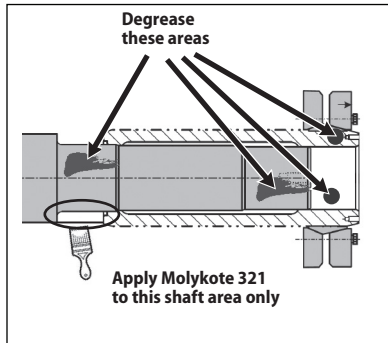

1

Clean and degrease contact surfaces; reducer shaft and bore, and the machine driven shaft.

Apply Molykote 321 or an equivalent dry film lubricant to the driven shaft projection opposite from the shrink disc.



Do not apply any friction minimizing compound to the driven shaft at or near the shrink disc.

2

Align the driven shaft with the bore of reducer/gearmotor bore and carefully slide unit onto the driven shaft.

If the fit is tight, strike on the reducer hollow bore with a mallet to assist in the assembly.



If using a soft non-metallic mallet during installation, strike **only** against the unit's steel hollow bore. **Do not** strike the reducer housing or oil seal. Damage to the bearings, the housing, and/or the seals may occur.

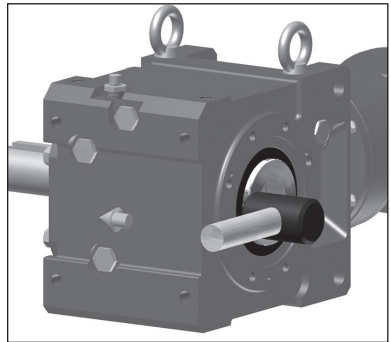

Note: If the fit is tight, use a jig such as the one shown in **Table 1** to ease assembly. **Sumitomo does not supply a mounting jig. This information is provided for reference only.**



Never tighten locking screws before shaft installation. Inner ring may become permanently contracted even at low tightening torques.



Ensure that all power switches are locked out before installing or removing shrink disc. Wear safety glasses and protective clothing at all times.

3

Remove any wooden spacers that may have been used during shipping. Lightly lubricate the hub outside diameter and shrink disc bore.

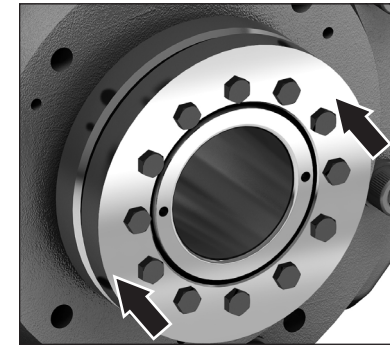

4

Set the (untightened) shrink disc on the reducer shaft.

5

After confirming the correct position of the hub and shrink discs, hand tighten three or four equally spaced locking screws and ensure the discs are parallel. Hand-tighten remaining locking screws.

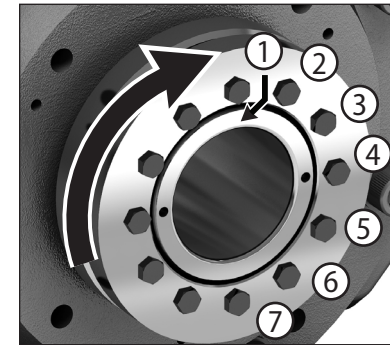

6

Using a torque wrench, tighten the screws according to the **initial torque** listed in **Table 2**. Tighten in either a clockwise or counter-clockwise sequence, using $\frac{1}{4}$ turns, until you can no longer complete a $\frac{1}{4}$ turn for any of the screws. This procedure keeps the discs parallel.

7

Continue to tighten the screws for two more passes. This compensates for system induced relaxing of the locking screws.

8

Set the torque wrench to the **final torque** and tighten all locking screws. At this point, no screw should turn; otherwise, set the torque wrench to the **initial torque** and repeat steps 6 and 7 above. It is **not** necessary to re-torque after equipment has been in operation.

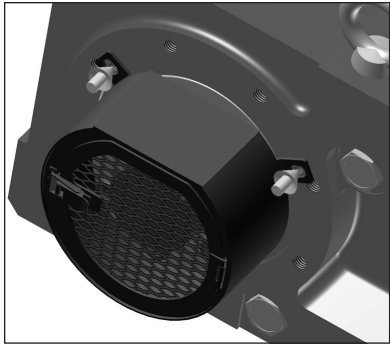

9

For units with a safety cover, reinstall the guard over the **shrink disc**.



Do not operate unit until the torque arm has been attached. Refer to the **Torque Arm Installation** section in this guide for instructions.

Table 2. Shrink Disc Size and Tightening Torque

Screw Size	M5	M6	M8	M10	M12	M16
Initial Torque (Nm)	5.1	12.4	31	63	105	263
Final Torque (Nm)	4.9	12	30	60	100	251
Socket Size (mm)	8	10	13	17	19	24

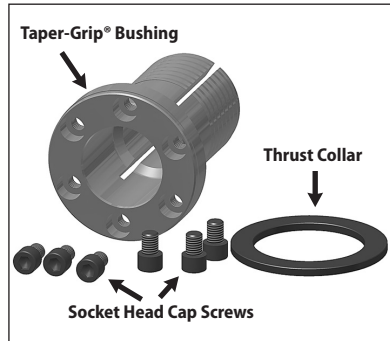

Taper-Grip® Bushing

Prior to installation of the gearbox onto the driven shaft, ensure that the shaft length meets or exceeds the minimum shaft engagement value "TT" detailed in **Table 3**.

Table 3. Driven Shaft Tolerance & Minimum Shaft Engagement

Shaft Diameter (in)	Tolerance (in)	Shaft Diameter (mm)	Tolerance (µm)
1-3/16 – 1-15/16	+0 / -0.0015	(30 - 50)	(+0 / -39)
2 – 3-1/8	+0 / -0.0018	(50 - 80)	(+0 / -46)
3-3/16 – 4-11/16	+0 / -0.0021	(80 - 120)	(+0 / -54)
4-3/4 – 6-1/2	+0 / -0.0025	(120 - 180)	(+0 / -63)

Reducer Size BBB	TT (in)	TT (mm)	Reducer Size HBB	TT (in)	TT (mm)
4A	7.8	198	AA/Z	4.5	113
4B	9.4	237	A	5	126
4C	11	279	B	5.7	143
4D	12.9	326	C	7.4	186
4E	14.2	359	D	8.1	204
4F	16.3	412	E	8.9	224

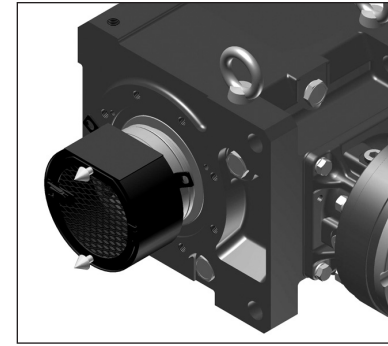
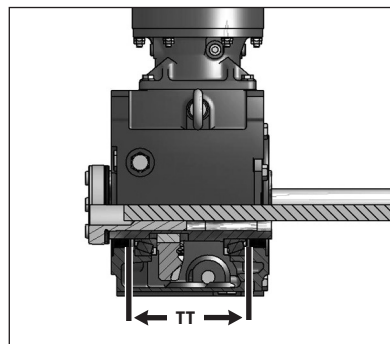

1

Remove **bushing cover** if unit was supplied with one.

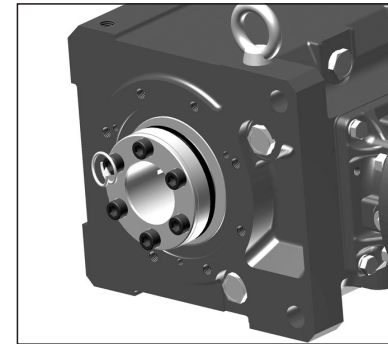

2

Loosen socket head cap screws.

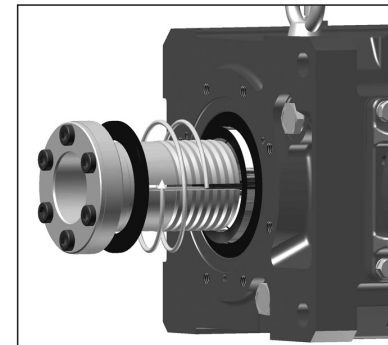

3

Remove (unscrew) Taper-Grip® bushing from the unit.

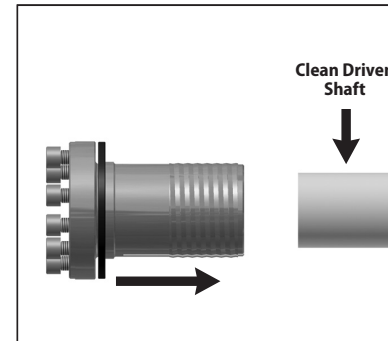

4

Clean all **grease, oil** and/or **anti-seize grease** from the driven shaft. Failure to do so could result in damage to shaft.

Slide Taper-Grip® bushing onto driven shaft.

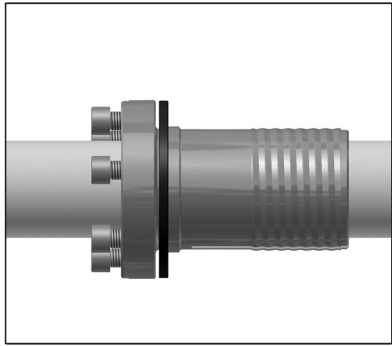

5

Inspect and test Taper-Grip® bushing on shaft.

- Check shaft for **burrs, corrosion, or warpage**. Repair or replace shaft as necessary.
- Slide bushing back and forth along shaft, checking for surface irregularities and fit.
- Verify bushing is sized correctly for the shaft diameter.

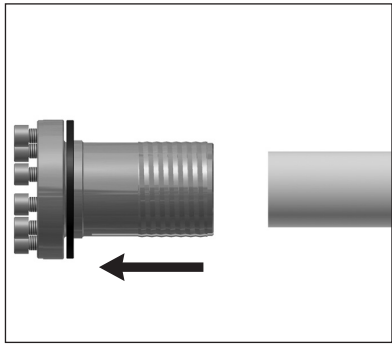

6

Remove Taper-Grip® bushing from driven shaft.

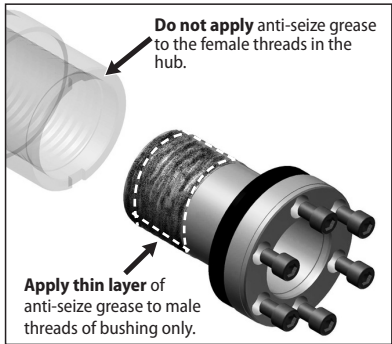

7

Apply a thin layer of anti-seize grease to the male threads of the Taper-Grip® bushing only.



Ensure that the anti-seize grease does not enter the Taper-Grip® bushing bore.

Do not apply anti-seize grease to the female threads in the hub.

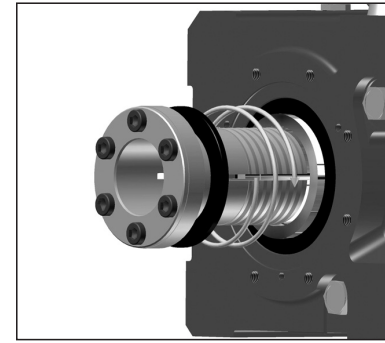

8

Screw Taper-Grip® bushing into the reducer leaving **approximately 1 mm gap between the bushing flange and thrust collar**.



Do not apply grease, oil, or anti-seize grease to the driven shaft or the bushing bore before placing the unit onto driven shaft. Use of these friction-minimizing products will adversely affect the ability of the unit to transmit torque.



CAUTION: The reducer must be externally supported prior to insertion of driven shaft into bushing. External support **MUST** be maintained until all bushing socket head cap screws have been tightened to the appropriate operational torque.

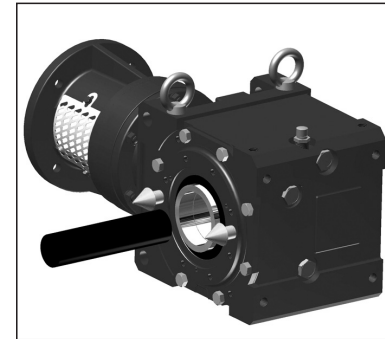

9

Mount or slide the reducer onto the driven shaft



Do not rock or pry the unit.

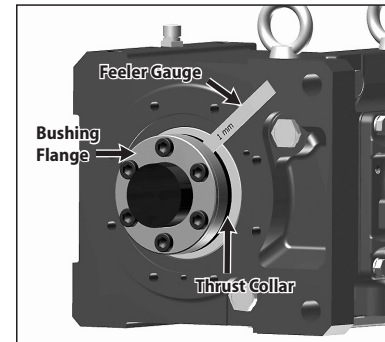

10

Screw Bolts into Taper-Grip® bushing.

- Lightly oil threads of each bolt before inserting.
- Finger tighten each bolt to secure in place.
- Be sure to **maintain the 1 mm** (approximate) **gap** between the **thrust collar** and the **bushing flange**.

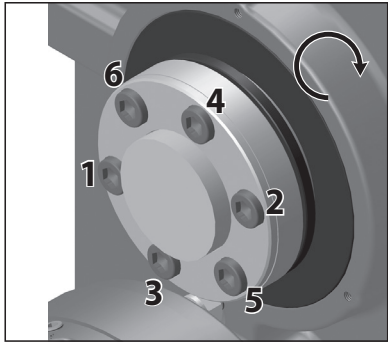

11

Tighten bushing bolts to the correct torque value.

- Following a **star pattern**, use a torque wrench to **gradually tighten each socket head cap screw in 20% increments**.
- Refer to **Table 4, Taper-Grip® Bushing Bolt Tightening Torques**, for the correct operational screw torques.

Table 4. Taper-Grip® Bushing Bolt Tightening Torques

Reducer Size BBB	Screw Qty x Size	Screw Torque	
		ft-lb	(Nm)
4A	6 x M12	56	(75)
4B	6 x M12	104	(140)
4C	6 x M16	185	(250)
4D	6 x M16	223	(300)
4E	8 x M16	223	(300)
4F	10 x M16	223	(300)

Reducer Size HBB	Screw Qty x Size	Screw Torque	
		ft-lb	(Nm)
AA/Z	6 x M10	23	31
A	6 x M12	38	51
B	6 x M12	38	51
C	6 x M16	94	128
D	6 x M16	148	200
E	8 x M16	148	200

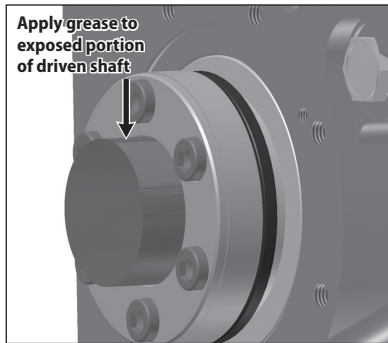

12

After installing and tightening the bushing bolts with a torque wrench, **apply grease or an anti-corrosion product** to the exposed portion of the shaft.

13

After the reducer has been running for 20 to 30 hours, re-torque the screws to the values in **Table 2**. Screw torques should be subsequently checked at normal service intervals (i.e. every 6 months).

14

For units that include a bushing safety cover, reinstall the guard over the Taper-Grip® bushing.



Do not operate unit until the torque arm has been attached to the unit and fixed to a rigid structure. The torque arm prevents counter-rotation during unit operation. Refer to torque arm installation section in this manual for instructions.

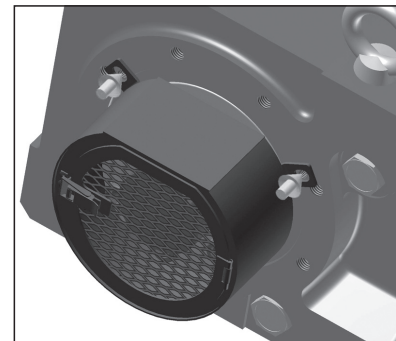

Turnbuckle Torque Arm

Turnbuckle Type Torque Arm

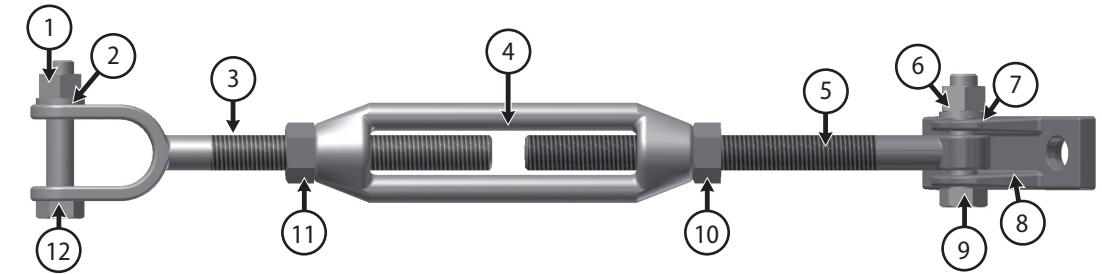

Table 5. Turnbuckle Type Torque Arm Parts

Item	Description	Item	Description
1	Hex Nut	7	Lock Washer
2	Lock Washer	8	Fulcrum Mounting Bracket
3	Threaded Extension Rod	9	Hex Bolt
4	Turnbuckle	10	Locking Nut (if supplied)
5	Threaded Arm	11	Locking Nut (if supplied)
6	Hex Nut	12	Hex Bolt

Table 6. Bolt Tightening Torque

Bolt Size [1]	Torque	
	ft-lb	(Nm)
M16	155 - 165	210 - 225
M20	290 - 320	395 - 430
M24	510 - 555	690 - 755
M30	1020 - 1110	1380 - 1510

Note: [1] Bolt ISO/JIS Class 8.8

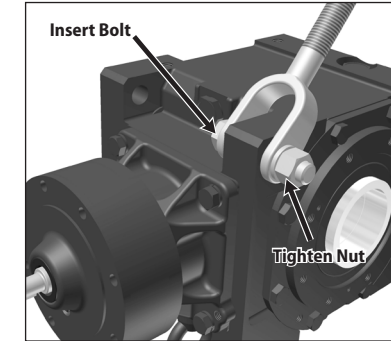

1

Attach the torque arm threaded extension rod to the bevel housing, at the housing corner eyelet, using the appropriate nut, bolt and lockwasher.

Insert the bolt through the brackets, torque arm sleeve (if supplied) and reducer housing eyelet.

Place the lockwasher on the bolt and secure with nut per the torque values given in **Table 6**.

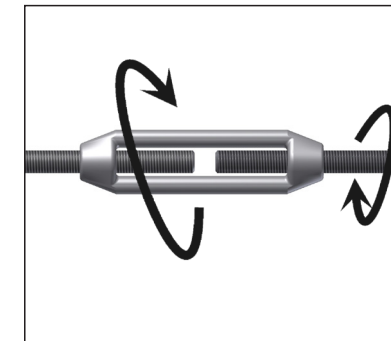

2

Install the turnbuckle onto the threaded extension rod (gearbox side) and then threaded arm (foundation side) to the turnbuckle.

If the assembly was supplied with hex nuts to secure the turnbuckle, install the nuts loosely, ensuring the left hand nut is used on the threaded arm, prior to installing the turnbuckle and threaded arm.

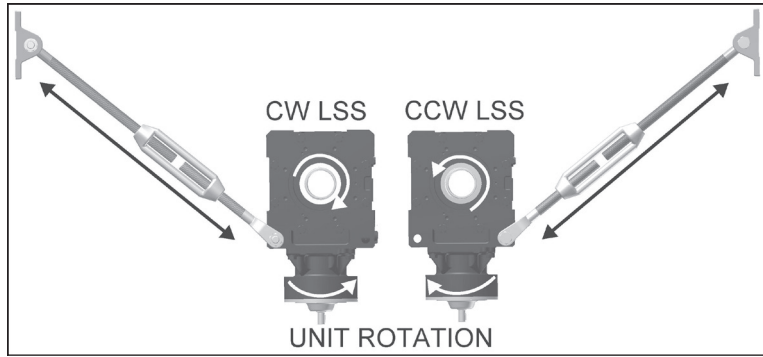

3 Position the torque arm so it will be in tension during unit operation and mount the fulcrum mounting bracket to suitable structure or foundation.

Mounting hardware for fulcrum mounting bracket are NOT supplied by Sumitomo.

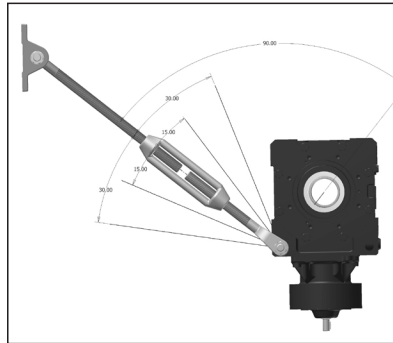

4 Position the torque arm as close as possible to 90° relative to the unit output bore / driven equipment shaft.

Sumitomo does not recommend the use of multiple torque arm assemblies to achieve a greater overall length.

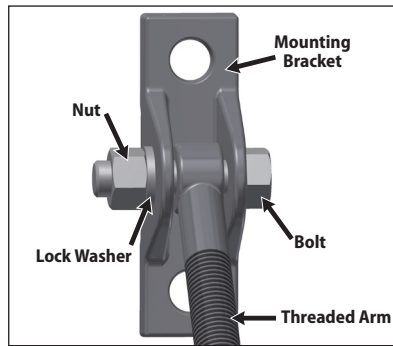

5 Assemble the threaded arm to the fulcrum mounting bracket, as shown. Some adjustment of the turnbuckle may be required to lengthen or shorten the overall length. Secure it with the appropriate nut, bolt and lockwasher.

- Insert the bolt through the brackets and threaded arm eyelet.
- Place the lockwasher on the bolt and secure with nut per the torque values given in **Table 6**.

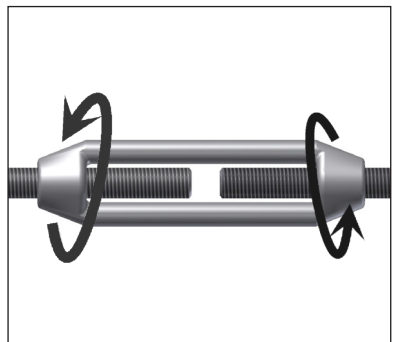

6 If turnbuckle hex nuts were supplied, secure the turnbuckle position by adjusting the previously installed turnbuckle nuts.

Tie Rod Torque Arm

Tie Rod Type Torque Arm

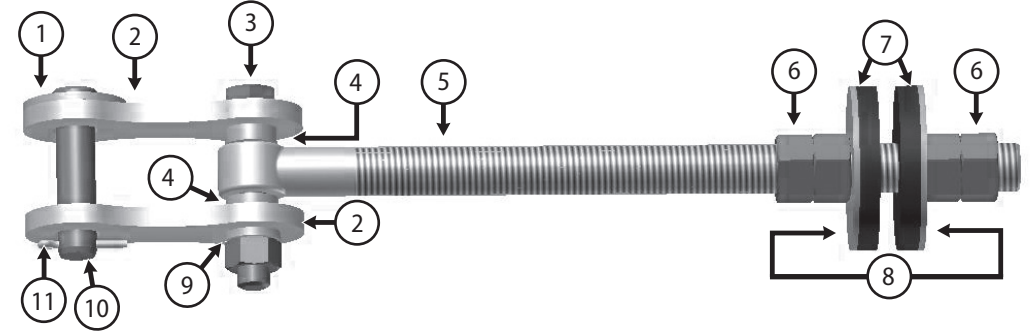

Table 7. Tie Rod Type Torque Arm Parts

Item	Description	Item	Description
1	Flat Washer	7	Rubber Bushing
2	(2) Mounting Brackets or (1) Clevis	8	Washers
3	Hex Bolt	9	Lock Washer
4	Spacer	10	Clevis Pin
5	Threaded Arm	11	Cotter Pin
6	Hex Nut		

Table 8. Bolt Tightening Torque

Bolt Size ^[1]	Torque	
	ft-lb	(Nm)
M16	155 - 165	210 - 225
M20	290 - 320	395 - 430
M24	510 - 555	690 - 755
M30	1020 - 1110	1380 - 1510

Note: [1] Bolt ISO/JIS Class 8.8

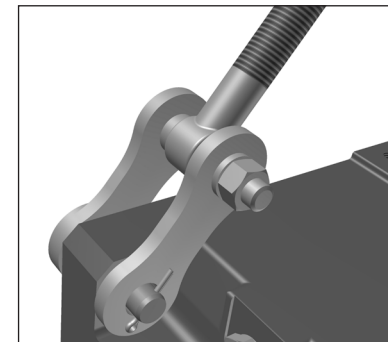

1 Assemble the torque arm mounting brackets or wishbone clevis to the threaded arm, and attach the torque arm assembly to the bevel housing, at the housing corner eyelet, using the pin and cotter pin. Tighten mounting bolts according to the values listed in **Table 8**.

- Insert the clevis pin through the brackets and housing eyelet.
- Insert the cotter pin into clevis pin and secure assembly.

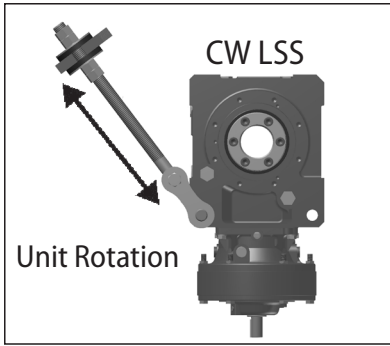

2 Position the torque arm so it will be in tension during unit operation.

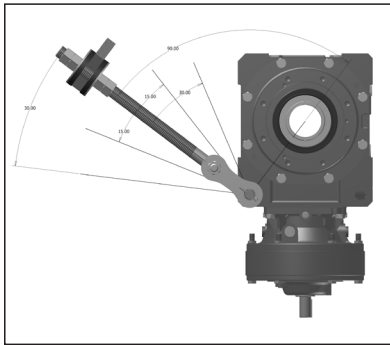

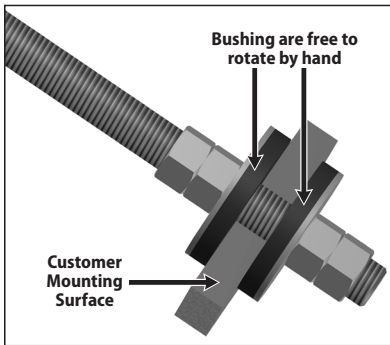

3 Position the torque arm as close as possible to 90° relative to the unit output bore / driven equipment shaft.

 Sumitomo does not recommend the use of multiple torque arm assemblies to achieve a greater overall length.



4 After inserting the torque rod into the mounting surface, carefully tighten nuts on either side of torque rod.

 Do **not** over tighten nuts. Tighten to point where rubber bushings can still be hand rotated when the unit is turned off.

 Before starting unit, verify the following:

- The torque arm will be in tension when the unit is in operation.
- The torque arm is aligned with the reducer housing.
- The torque arm is perpendicular to the axis of the output/driven shaft.
- The threaded arm is not touching the reducer housing.



Ensure the torque arm has correct alignment and will be in tension during operation.

Correct

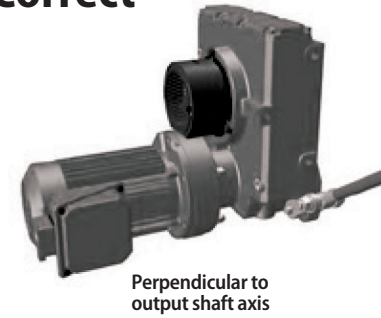

Incorrect

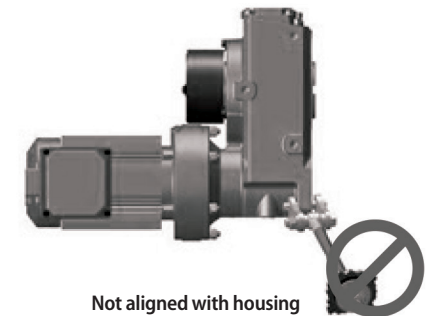
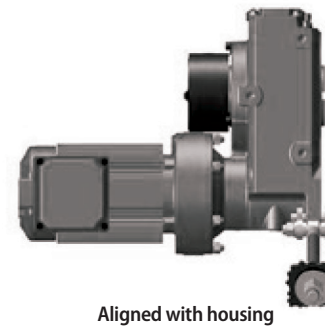

Direct Mount Torque Arms in Tension

“Y3” Mounting Position

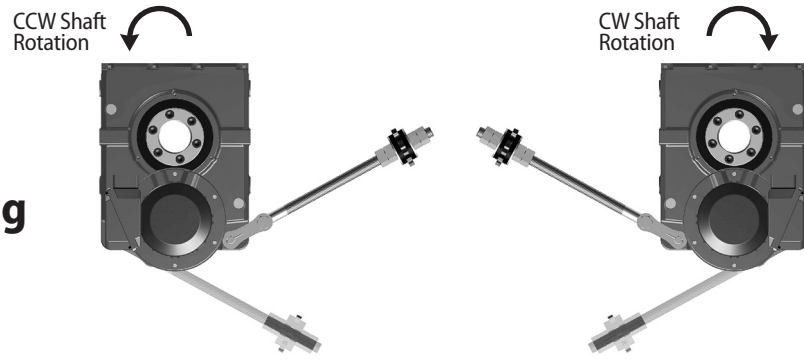

“Y1” Mounting Position

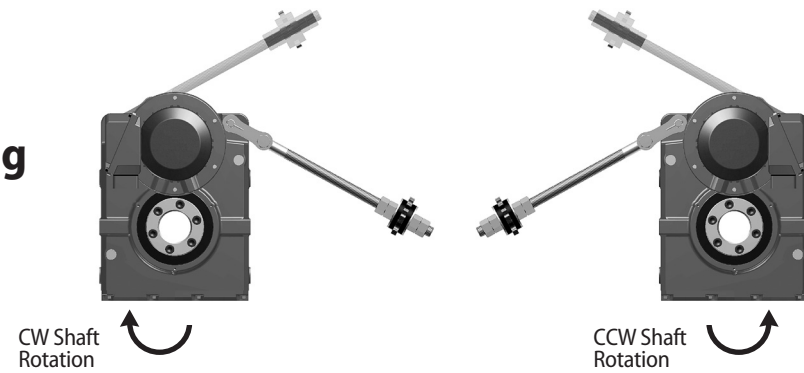

T-Type Torque Arm

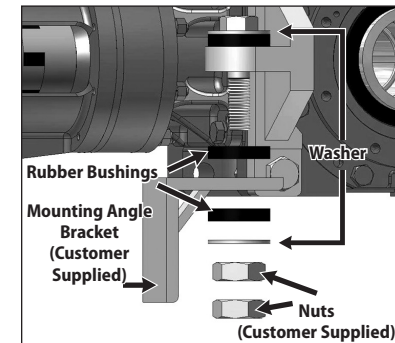
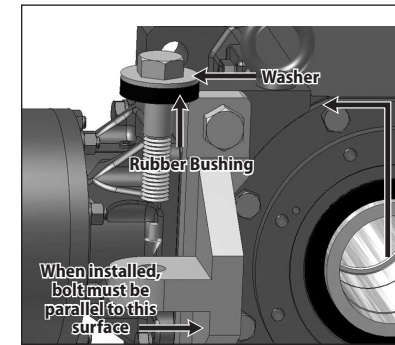
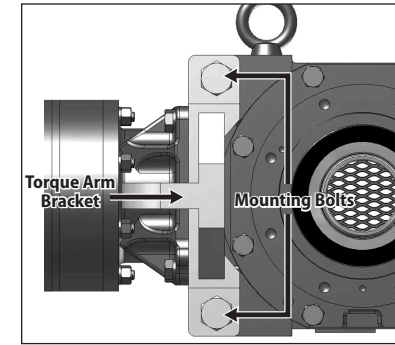

1

Attach the T-Type Bracket to the reducer using the supplied mounting hardware. Tighten mounting the bolts according to the values listed in **Table 9**.

Table 9. Bolt Tightening Torque

Bolt Size ^[1]	Torque	
	ft-lb	(Nm)
M16	155 - 165	210 - 225
M20	290 - 320	395 - 430
M24	510 - 555	690 - 755
M30	1020 - 1110	1380 - 1510

Note: [1] Bolt ISO/JIS Class 8.8

2

Place washer and rubber bushing on bolt.

Insert torque arm bolt (supplied by customer) through mounting tab on Banjo torque arm.



Make sure bolt is parallel to T-Type Torque Arm side when fully installed.

3

Follow these steps to attach the mounting angle bracket:

- Place rubber bushing and mounting angle bracket on the bolt.
- Verify that the mounting angle bracket hole is the correct diameter for customer supplied bolt.
- Place remaining bushing, washer and two nuts on the bolt.

Do not over-tighten nuts. Tighten to point where rubber bushings can still be hand rotated.

Table 10. Recommended Bolt Size

Bracket Tab Bore	Typical Bolt Size ^[1]
Ø18 mm	M16
Ø22 mm	M20
Ø26 mm	M24
Ø33 mm	M24
Ø39 mm	M36

Note^[1] Bolt class should be greater or equal to ISO/JIS Class 8.8. Application with multiple start/stops and/or shock loading should be 10.9 at a minimum.

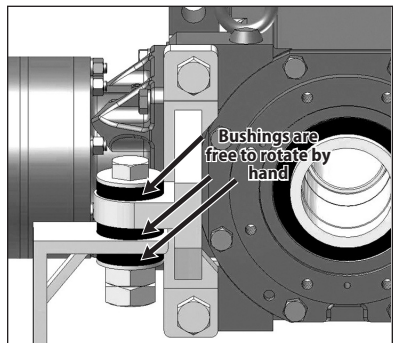

4

Confirm that the **rubber bushings** can still be rotated by hand. This indicates the bushing has not been over-tightened.

Compressed bushings will not allow the bushings to properly absorb the loads of the shaft mounted gearbox. This can lead to premature failure.



Mounting angle bracket must be secured to the machine structure.

5

Confirm the mounting angle bracket does not interfere with the torque arm. There should be no metal-to-metal contact between the two during a complete revolution of the driven equipment.



Metal-to-Metal contact between these two components may lead to catastrophic failure of the reducer/gearmotor.

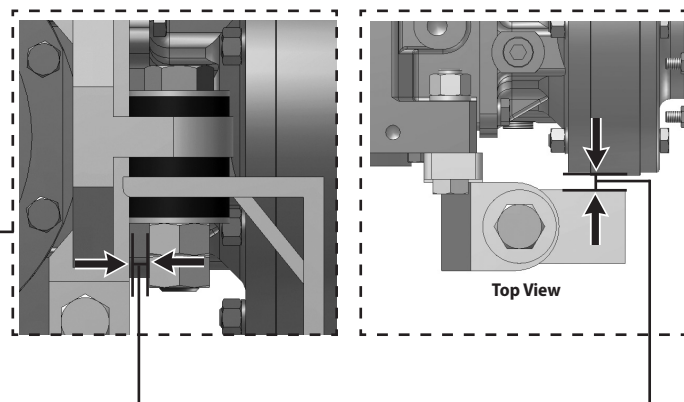
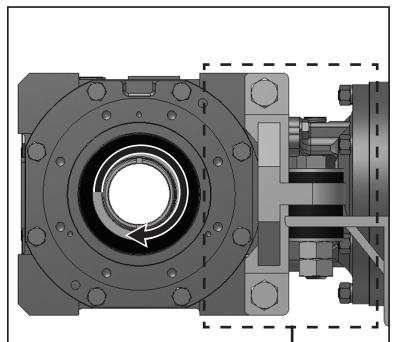

Banjo Type Torque Arm

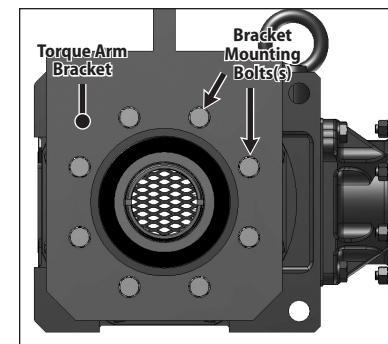

1

Attach the Flange Mount (Banjo) Torque Arm Bracket to the reducer using mounting hardware.

Table 11. Bolt Tightening Torque

Bolt Size ^[1]	Torque	
	ft-lb	(Nm)
M16	155 - 165	210 - 225
M20	290 - 320	395 - 430
M24	510 - 555	690 - 755
M30	1020 - 1110	1380 - 1510

Note: [1] Bolt ISO/JIS Class 8.8

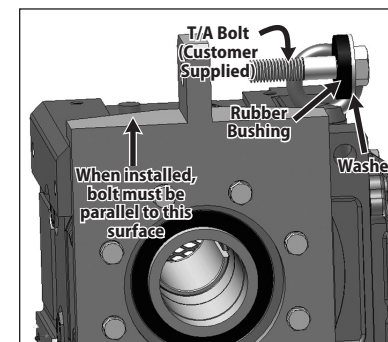

2

Place washer and rubber bushing on bolt. Insert torque arm bolt (supplied by customer) through mounting tab on Flange Mount (Banjo) type torque arm.



Make sure bolt is parallel to Flange Mount (Banjo) Type torque arm surface when fully installed.

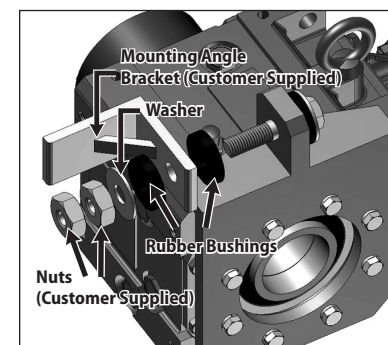

3

Follow these steps to attach the torque arm to mounting structure or mounting angle bracket (customer supplied):

- Verify that the mounting structure or mounting angle bracket hole is the correct diameter.
- Place rubber bushing and mounting angle bracket on bolt.
- Ensure the bolt passes through mounting structure or mounting angle bracket hole.
- Place remaining bushing, washer and two nuts on the bolt.



Do not over-tighten nuts. Tighten to point where rubber bushings can still be hand rotated.

Table 12. Recommended Bolt Size

Bracket Tab Bore	Typical Bolt Size ⁽¹⁾
Ø18 mm	M16
Ø22 mm	M20
Ø26 mm	M24
Ø33 mm	M24
Ø39 mm	M36

Note ⁽¹⁾ Bolt class should be greater or equal to ISO/JIS Class 8.8. Application with multiple start/stops and/or shock loading should be 10.9 at a minimum.

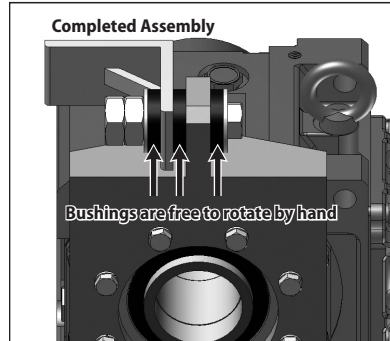

4

Confirm that the rubber bushings can still be rotated by hand. This indicates the bushing has not been over-tightened.



Compressed bushings will not allow the bushings to properly absorb the loads of the shaft mounted gearbox. This can lead to premature failure.

If used, the mounting angle bracket must be secured to the machine structure.

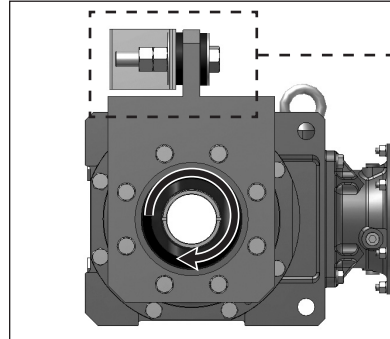

5

Confirm the mounting angle bracket does not interfere with the torque arm. There should be no metal-to-metal contact between the two during a complete revolution of the driven equipment.



Metal-to-Metal contact between these two components may lead to catastrophic failure of the reducer/gearmotor.

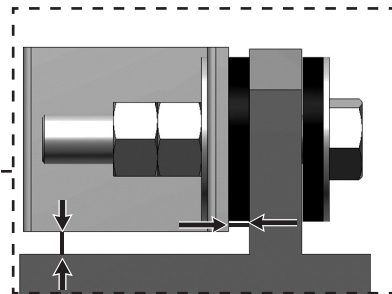

Flange Mount

Handle with care in order not to apply excessive force to the driven shaft or hollow shaft by twisting the reducer casing.

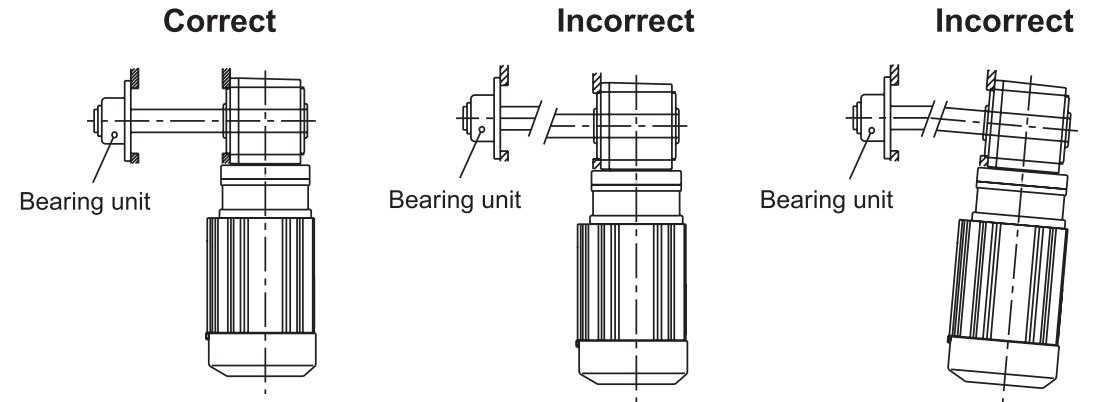

Motor Mounting

Reducer Supplied with Motor:

Some units may come from the factory with the motor attached. In this case, no additional preparation is required.

Quill Input Reducer (Non-Food Grade)

Reducer Supplied with Motor:

- Inspect the shaft hollow bore and the motor shaft for debris or other material that may prevent the insertion of the motor shaft into the hollow quill input shaft – carefully clean if necessary.
- To enable easy installation and removal of the motor, apply anti-seize paste to both the reducer hollow bore and the motor shaft.
- Place the motor key into the motor shaft and carefully insert the motor into the quill high-speed shaft of the reducer.
- Ensure that the motor flange bolts are aligned with the through holes of the reducer flange, and also ensure that the motor is properly aligned with the reducer.
- Bolt the motor into place. Refer to the motor operating instructions for proper bolt tightening torque.

Quill Input Reducer (Food Grade)

Supplied without Motor:

Hollow input shaft units for the Food and Beverage industry have either an o-ring or a gasket for installation between the motor and reducer.

Installation Instructions

1. Make sure that the o-ring is in the o-ring groove, or that the gasket is in place.
2. Apply a thin film of the supplied food-grade anti-seize paste to the hollow shaft. Save enough anti-seize paste to coat the Cyclo output shaft.

Motor Wiring



The motor diagram found inside Sumitomo supplied motor conduit box cover is correct. If using a motor manufactured by a company other than Sumitomo, please refer to that manufacturer's instruction manual for wiring, operating and maintenance details. When wiring motors into the power supply, Sumitomo recommends the use of terminal rings to facilitate the connection.



- Protection for overloads, peak starting currents, short circuit currents and ground fault currents should be in strict compliance with the National Electric Code (latest release) Article 430, local electrical codes and building codes in order to minimize the possibility of personal injury, electrical shock, and fire.
- Disconnect the motor from the power supply and implement Lock Out/Tag Out procedures before opening the motor conduit box and performing any motor maintenance.
- Do not handle the unit when cables are live.
Be sure to disconnect the power; otherwise electric shock may result.
- Ensure ambient is within manufacturer's published ratings.
For Sumitomo TEFC motors, those are: -10 to 40°C, under 85% humidity, under 1000 meters altitude, free of corrosive gases, explosive gases, vapors and dust.
- Keep all wiring and electrical parts dry and moisture free.
- Ensure the motor is installed in an area of unrestricted ventilation.
- Verify the power supply voltage and frequency values are within nameplate ratings: voltage +/- 10%, frequency +/- 5%. The arithmetic sum of voltage and frequency variations should not exceed 10%.



- Verify voltage imbalance between phases is no greater than 2%.
- Connect the power cabling to the motor according to the diagram inside the Sumitomo's motor conduit box cover or according to the instructions supplied with another manufacturer's motor; otherwise electric shock or fire may result.
- Properly ground the motor: otherwise electric shock may result.
- The use of long power wiring can result in voltage drop.
Size power cabling to limit voltage drop to less than 2%.
- When wiring motors into the power supply, Sumitomo recommends the use of terminal rings to facilitate the connection.
- After wiring the motor, check that the conduit box mounting and cover hardware is tight.
- For brake motors:
Ensure the brake coil rectifier is installed in an ambient less than 60°C.
Do not apply power continuously to the brake coil of a stopped brakemotor.
The brake coil will overheat, be damaged and may cause a fire.
- For single-phase motors, exercise caution so as not to damage the vinyl cover of the starting capacitor: otherwise electrical shock may result.

Motor Protection



- Use a molded case circuit breaker for protection against short circuit.
- Use an overload protection device that protects the unit against voltage surges.

Lubrication

Inspection of Lubrication Method

- **Caution: Before** following the instructions below, **read all lubrication stickers on the unit** to determine the lubrication type. Instructions listed on stickers supersede the instructions in this guide.
- Oil lubricated units are shipped without oil, unless the customer specified otherwise when the unit was ordered. Always fill the unit with the correct type and quantity of lubricant prior to operation.
- **Some oil-lubricated models may be shipped from the factory already filled to the correct level with oil.** A unit pre-lubricated with oil has a tag attached that identifies it as pre-filled. If a unit is pre-lubricated with oil, no additional oil is needed. **Before starting the unit, replace the oil fill plug with the air breather shipped with the reducer.**
- **Models ordered without oil must be filled with lubricant before startup.**
- Certain models must be filled with lubricant in two separate locations, the bevel or helical gear portion (output) and the input portion.
- **Grease lubricated models are filled with grease prior to shipping.** Additional grease is not necessary.
- Consult the Operations and Maintenance Manual for additional lubrication information.

Oil Supply Procedures



- Always stop the unit before adding oil.
 - Oil level may drop during operation, depending on the oil viscosity, temperature and direction of rotation. Additional oil is not necessary. Check the oil level when the unit is stopped to ensure that it has the correct amount of oil.
- 
- It may take some time for the oil to settle when the oil viscosity is high.
 - There may be two different oil fill locations for some combinations; refer to **Oil Fill/Drain Locations**.
 - Consider implementing an oil analysis program to ensure lubricant continues to operate at peak performance. Follow your lubrication provider's oil analysis recommendations to ensure reducer performance.
 - Always consult factory and warehouses for overhaul of gearmotors and reducers. Familiarity with Cyclo® products is necessary for proper overhaul.
 - **Do not overfill with oil!** If overfilled, the unit's operating temperature will rise too high and/or oil will leak through the high speed shaft oil seal.

1. Remove the oil fill plug, as referenced in **Oil Fill/Drain Locations**.
2. Slowly add oil while checking the level through the oil bullseye, overfill plug, or gauge.
3. After the oil has settled, make sure the oil level is visible in the bulls eye, overfill plug, or upper red line of the Cyclo oil level gauge.
4. Insert the oil fill plug after wrapping it with sealing compound or tape.

Hyponic® and BBBH

Hyponic® and BBBH speed reducers are grease lubricated as a standard. Consult factory for lubrication information for non-standard oil lubricated units.

Cyclo® 6000, HBB, BBB4 and BBB5

Recommended Oils

Oils that may be used to lubricate the Bevel Gear portion of the unit. These oils may also be used in the Cyclo® portion if it is oil lubricated.

Gulf Oil:	EP Lubricant HD	Shell Oil:	Omala S2 G	Kluber:	Kluberoil GEM1
ExxonMobil Oil:	Spartan EP	Caltex:	Meropa	Idemitsu Oil:	Daphane Mechanic
Mobil Oil:	Mobilgear 600XP	Castrol:	Alpha SP	BP Oil:	Energol GR-XP
Total:	Carter EP	Food Grade Oil: Klübersynth UH1 6-460			

Table 13. Ambient Temperatures

°F	14	32	50	68	86	104	122
°C	-10	0	10	20	30	40	50
ISO VG	68* (14 °F to 41 °F)						
	100/150 (32 °F to 95 °F)						
				220/320/460 (86 °F to 122 °F)			

*VG68 is not available for ExxonMobil Spartan.

- Use lubricants with low viscosity for operation during winter or at relatively low temperatures.
- Use lubricant with a viscosity within the range listed in **Table 14, Recommended Oil Viscosity**.

Table 14. Recommended Oil Viscosity

Minimum allowable viscosity	15 cSt (mm^2/s) or more at operating temperature	Viscosity that ensures oil film strength adequate for load transmission
Maximum allowable viscosity	4300 cSt (mm^2/s) max	Viscosity that permits start-up of BuddyBox®

- Consult a local distributor, nearest authorized agent or Sumitomo directly when the unit will be operated in ambient temperatures other than 14° to 104°F (-10° to 40°C). Special unit modifications may be necessary.

Table 15. Oil Change Intervals

Task	Change Interval		Conditions of Use
Supply of Oil	At Installation		All
Oil Change	First Change	500 hrs operation or 6 months, whichever comes first.	All
	Second change and thereafter	2500 hrs operation or 6 months, whichever comes first.	When case oil temperature is 158° F (70° C) or higher
		5000 hrs operation or 1 year, whichever comes first.	When case oil temperature is lower than 158° F (70° C)

Table 16. Recommended Food Grade Oil

Ambient Temp.		ISO Grade	Recommended Oil
°F	°C		
32 to 95	0 to 35	460	Klübersynth UH1 6-460

Cyclo® 6000 Oil Fill Quantities

Table 17. Approximate Oil Quantity

Units: US liquid gallon (*liter*)

Frame Size	Mounting Configuration			Frame Size	Mounting Configuration		
	CHH or CHV	CVV	CHF		CHH or CHV	CVV	CHF
6130, 6135	0.18 (0.68)	0.29 (1.1)	0.07 (.25)	6160DC, 6165DC	0.40 (1.5)	0.26 (1)	0.26 (1)
6140, 6145, 614H	0.18 (0.68)	0.29 (1.1)	0.07 (.25)	6170DC, 6175DC	0.63 (2.4)	0.5 (1.9)	0.53 (2.0)
6160, 6165, 616H	0.37 (1.4)	0.26 (1.0)	0.24 (0.9)	6180DB, 6185DB	0.92 (3.5)	0.53 (2.0)	0.61 (2.3)
6170, 6175	0.50 (1.9)	0.50 (1.9)	0.40 (1.5)	6190DA, 6195DA	1.5 (5.8)	0.71 (2.7)	1.0 (3.8)
6180, 6185	0.66 (2.5)	0.53 (2.0)	0.34 (1.3)	6190DB, 6195DB	1.6 (6.0)	0.71 (2.7)	1.1 (4.0)
6190, 6195	1.1 (4)	0.71 (2.7)	0.53 (2.0)	6205DA, 6205DB	1.6 (6.0)	2.9 (11)	1.1 (4.0)
6205	1.5 (5.5)	1.5 (5.7)	0.79 (3)	6215DA, 6215DB	2.6 (10)	3.7 (14)	1.5 (5.5)
6215	2.2 (8.5)	2.0 (7.5)	1.1 (4)	6225DA, 6225DB	2.9 (11)	4.8 (18)	1.6 (6.0)
6225	2.6 (10)	2.6 (10)	1.3 (5)	6235DA, 6235DB	4.5 (17)	6.1 (23)	2.5 (9.5)
6235	4.0 (15)	3.2 (12)	2.0 (7.5)	6245DA, 6245DB	4.8 (18)	7.7 (29)	2.6 (10)
6245	4.2 (16)	4.0 (15)	2.1 (8)	6255DA, 6255DB	6.1 (23)	11.1 (42)	3.4 (13)
6255	5.5 (21)	11.1 (42)	2.9 (11)	6265DA	8.5 (32)	13.5 (51)	4.5 (17)
6265	7.7 (29)	13.5 (51)	3.7 (14)	6275DA	15.9 (60)	15.9 (60)	
6275	14.8 (56)	15.9 (60)	7.9 (30)				

CHH = Cyclo Horizontal Foot Mounted

CVV = Cyclo Vertical V-Flange Mounted

CHV = Cyclo Horizontal V-Flange Mounted

CHF = Cyclo Horizontal Flange Mounted

Note: Please consult factory for oil quantities for when the reducer is mounted in any other position or angle.

Cyclo® 6000 Oil Fill Levels

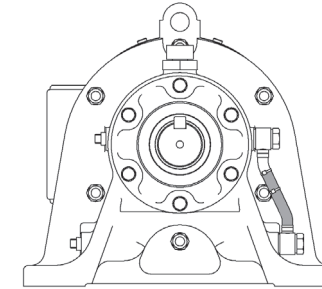

Horizontal

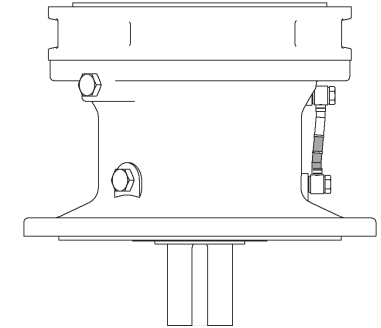

Vertical

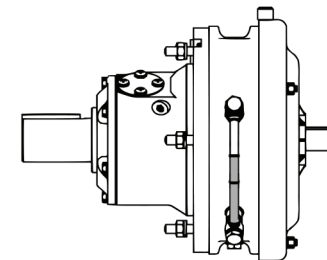

Horizontal Flange Mount

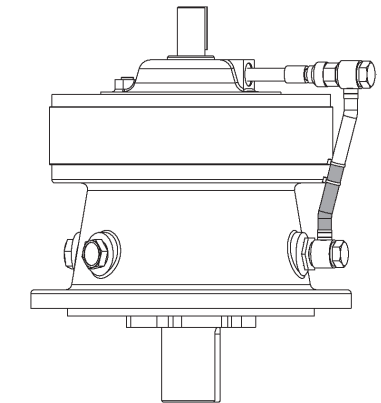

Vertical

Sizes 6130/5 and 6140/5 only

BBB4 and BBB5 in the Y4 Position



Sumitomo Cyclo® BBB4s are typically shipped from the factory without lubricating oil, unless the customer specified otherwise when the unit was ordered.

The unit must contain the correct type and amount of lubrication before operating.



For all Y4 motor down mounting configurations, the Cyclo® portion is filled at the factory with grease. For these units, the Cyclo® portion does not need to be filled with lubricant before start-up. The Bevel Gear portion of models built for the Y4 mounting configuration still requires filling with gear oil before start-up. Refer to the Lubrication Method section for details.

For the Cyclo® BBB4, BBB5 built for the Y4 mounting configuration and all HBB, the Cyclo® and the output gear portions must be filled with lubricant separately and maintained separately. Lubricant does not flow from one section to the other.

Cyclo® BBB4 in Y4 Assembly

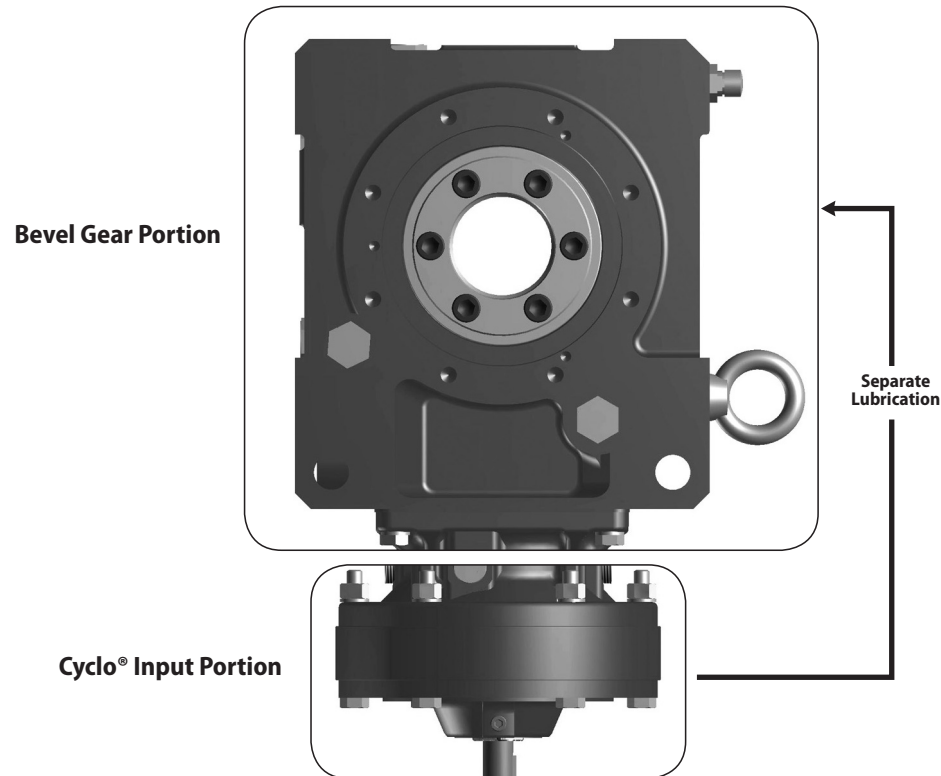

BBB4 Oil Quantities

Table 18. Single Reduction Approximate Oil Quantity

Units: US liquid gallon (*liter*) **Note: Output** = Bevel Gear Portion **Input** = Cyclo® Portion

Bevel Gear Unit Size	Mounting Configuration						
	Y1	Y3	Y2	Y4	Y5	Y6	
				Output	Input		
4A10	0.43 (1.62)		0.84 (3.17)	0.30 (1.13)	Grease	0.36 (1.36)	0.49 (1.84)
4A11	0.44 (1.66)		0.86 (3.26)			0.37 (1.40)	0.50 (1.88)
4A12	0.45 (1.71)		0.88 (3.35)			0.38 (1.45)	0.51 (1.93)
4A14	0.50 (1.91)		1.00 (3.77)			0.44 (1.65)	0.56 (2.13)
4B12	0.87 (3.29)		1.72 (6.50)	0.45 (1.72)	Grease	0.88 (3.34)	0.85 (3.23)
4B14	0.92 (3.49)		1.84 (6.97)			0.94 (3.54)	0.91 (3.43)
4B16	1.04 (3.92)		2.01 (7.61)			1.05 (3.97)	1.02 (3.86)
4C14	1.46 (5.52)		2.94 (11.1)	0.72 (2.72)	Grease	1.40 (5.30)	1.55 (5.88)
4C16	1.57 (5.96)		3.11 (11.8)			1.52 (5.74)	1.67 (6.32)
4C17	1.67 (6.34)		3.31 (12.5)			1.62 (6.12)	1.77 (6.70)
4D16	2.66 (10.1)		5.26 (19.9)	1.22 (4.61)	Grease	2.56 (9.69)	2.76 (10.4)
4D17	2.75 (10.4)		5.41 (20.5)			2.65 (10.0)	2.85 (10.8)
4D18	2.83 (10.7)		5.54 (21.0)			2.72 (10.3)	2.93 (11.1)
4E17	3.85 (14.6)		7.60 (28.8)	1.65 (6.26)	Grease	3.45 (13.1)	4.24 (16.1)
4E18	3.88 (14.7)		7.70 (29.1)			3.49 (13.2)	4.28 (16.2)
4E19	4.14 (15.7)		8.04 (30.4)			3.75 (14.2)	4.54 (17.2)
4F18	5.28 (20.0)		10.41 (39.4)	1.92 (7.28)	Grease	4.89 (18.5)	5.65 (21.4)
4F19	5.50 (20.8)		10.74 (40.6)			5.10 (19.3)	5.86 (22.2)

BBB4 Oil Quantities

Table 19. Double Reduction Approximate Oil Quantity

Units: US liquid gallon (*liter*) **Note: Output** = Bevel Gear Portion **Input** = Cyclo® Portion

Bevel Gear Unit Size	Mounting Configuration					
	Y1	Y3	Y2	Y4	Y5	Y6
	Output		Input			
4A10DA	0.44 (1.65)	0.84 (3.20)	0.30 (1.13)	Grease	0.37 (1.39)	0.49 (1.87)
4A12DA	0.46 (1.74)	0.89 (3.38)			0.39 (1.48)	0.52 (1.96)
4A12DB	0.47 (1.78)	0.90 (3.43)			0.40 (1.52)	0.53 (2.00)
4B12DA	0.88 (3.32)	1.73 (6.53)	0.45 (1.72)	Grease	0.89 (3.37)	0.86 (3.26)
4B12DB	0.89 (3.36)	1.73 (6.57)			0.90 (3.41)	0.87 (3.30)
4B14DA	0.93 (3.52)	1.85 (7.00)			0.94 (3.57)	0.91 (3.46)
4B14DB	0.94 (3.56)	1.86 (7.04)			0.95 (3.61)	0.92 (3.50)
4C14DA	1.47 (5.55)	2.95 (11.2)	0.72 (2.72)	Grease	1.41 (5.33)	1.56 (5.91)
4C14DB	1.48 (5.59)	2.96 (11.2)			1.42 (5.37)	1.57 (5.95)
4C14DC	1.49 (5.64)	2.97 (11.3)			1.43 (5.42)	1.59 (6.00)
4C16DA	1.59 (6.03)	3.13 (11.8)			1.53 (5.81)	1.69 (5.39)
4C16DB	1.61 (6.08)	3.14 (11.9)			1.55 (5.86)	1.70 (6.44)
4C17DA	1.69 (6.41)	3.33 (12.6)			1.63 (6.19)	1.79 (6.77)
4D16DA	2.68 (10.1)	5.27 (20.0)	1.22 (4.61)	Grease	2.58 (9.76)	2.77 (10.5)
4D16DB	2.69 (10.2)	5.29 (20.0)			2.59 (9.81)	2.79 (10.6)
4D17DB	2.78 (10.5)	5.44 (20.6)			2.68 (10.2)	2.88 (10.9)
4D17DC	2.82 (10.7)	5.48 (20.7)			2.72 (10.3)	2.91 (11.0)
4E17DA	3.86 (14.6)	7.62 (28.8)	1.65 (6.26)	Grease	3.47 (13.1)	4.26 (16.1)
4E17DB	3.88 (14.7)	7.63 (28.9)			3.48 (13.2)	4.27 (16.2)
4E17DC	3.91 (14.8)	7.67 (29.0)			3.52 (13.3)	4.31 (16.3)

BBB4 Oil Quantities

Table 19 Continued. Double Reduction Approximate Oil Quantity

Units: US liquid gallon (*liter*) **Note: Output** = Bevel Gear Portion **Input** = Cyclo® Portion

Bevel Gear Unit Size	Mounting Configuration						
	Y1	Y3	Y2	Y4	Y5	Y6	
	Output		Input				
4E18DA	3.9 (14.8)		7.7 (29.3)	1.7 (6.3)	Grease	3.5 (13.3)	4.3 (16.3)
4E18DB	4.1 (15.7)		7.8 (29.6)			3.8 (14.2)	4.5 (17.2)
4E19DA	4.6 (17.5)		8.2 (31)			4.2 (16)	5 (19)
4E19DB	4.7 (17.7)		8.2 (31)	1.9 (7.3)	Grease	4.3 (16.2)	5.1 (19.2)
4F18DA	5.3 (20.1)		10.5 (39.6)			4.9 (18.6)	5.7 (21.5)
4F18DB	5.5 (21)		10.5 (39.9)			5.2 (19.5)	5.9 (22.4)
4F19DA	6 (22.6)		10.9 (41.2)			5.6 (21.1)	6.3 (24)
4F19DB	6 (22.8)		10.9 (41.2)	5.6 (21.3)	6.4 (24.2)		

BBB5 Oil Fill Quantities

Table 20. Single Reduction Approximate Oil Quantity

Units: U.S. liquid gallon (*liter*) **Note: Output = Bevel Gear Portion Input = Cyclo®**

Bevel Gear Unit Size	Mounting Configuration					
	Y1		Y2		Y4	
	Y3	Y2	Output	Input	Y5	Y6
5Z10	0.21 (0.80)	0.42 (1.58)	0.18 (0.67)	Grease	0.17 (0.66)	0.24 (0.90)
5Z11	0.22 (0.85)	0.44 (1.65)			0.19 (0.71)	0.25 (0.95)
5Z12	0.25 (0.93)	0.47 (1.79)			0.21 (0.79)	0.27 (1.03)
5A11	0.42 (1.59)	0.81 (3.05)	0.22 (0.83)	Grease	0.36 (1.35)	0.49 (1.85)
5A12	0.44 (1.68)	0.85 (3.23)			0.38 (1.44)	0.51 (1.94)
5A14	0.50 (1.90)	0.95 (3.58)			0.44 (1.66)	0.57 (2.16)
5B12	0.70 (2.66)	1.37 (5.17)	0.42 (1.60)	Grease	0.60 (2.29)	0.81 (3.06)
5B14	0.76 (2.86)	1.46 (5.52)			0.66 (2.49)	0.86 (3.26)
5B16	0.88 (3.33)	1.63 (6.17)			0.78 (2.96)	0.99 (3.73)
5C14	1.41 (5.35)	2.84 (10.74)	0.93 (3.53)	Grease	1.33 (5.05)	1.50 (5.66)
5C16	1.61 (6.08)	3.07 (11.62)			1.53 (5.78)	1.69 (6.39)
5C17	1.72 (6.52)	3.20 (12.13)			1.64 (6.22)	1.80 (6.83)

Table 21. Double Reduction Approximate Oil Quantity

Units: U.S. liquid gallon (*liter*) **Note: Output = Bevel Gear Portion Input = Cyclo®**

Bevel Gear Unit Size	Mounting Configuration					
	Y1		Y2		Y4	
	Y3	Y2	Output	Input	Y5	Y6
5Z10DA	0.24 (0.89)	0.42 (1.60)	0.18 (0.70)	Grease	0.24 (0.91)	0.26 (1.00)
5Z12DA	0.24 (0.89)	0.47 (1.78)			0.29 (1.10)	0.29 (1.10)
5Z12DB	0.26 (0.99)	0.47 (1.78)			0.29 (1.11)	0.29 (1.10)
5A12DA	0.44 (1.68)	0.85 (3.23)	0.22 (0.83)	Grease	0.38 (1.44)	0.54 (2.04)
5A12DB	0.47 (1.78)	0.85 (3.23)			0.38 (1.44)	0.54 (2.04)
5B12DA	0.70 (2.66)	1.37 (5.17)			0.63 (2.39)	0.83 (3.16)
5B12DB	0.73 (2.76)	1.39 (5.27)	0.42 (1.60)	Grease	0.63 (2.39)	0.83 (3.16)
5B14DA	0.76 (2.86)	1.46 (5.52)			0.68 (2.59)	0.89 (3.36)
5B14DB	0.78 (2.96)	1.46 (5.52)			0.68 (2.59)	0.89 (3.36)
5C14DA	1.44 (5.45)	2.86 (10.84)	0.93 (3.53)	Grease	1.33 (5.05)	1.50 (5.66)
5C14DB	1.44 (5.45)	2.86 (10.84)			1.36 (5.15)	1.50 (5.66)
5C14DC	1.44 (5.45)	2.89 (10.94)			1.36 (5.15)	1.52 (5.76)
5C16DA	1.61 (6.08)	3.07 (11.62)			1.55 (5.88)	1.71 (6.49)
5C16DB	1.63 (6.18)	3.1 (11.72)			1.58 (5.98)	1.71 (6.49)

BBB4 and BBB5 Oil Fill/Drain Locations

○ Oil filler plug ◐ Oil level (Oil gauge) ● Oil drain plug ⊕ Oil fill air vent

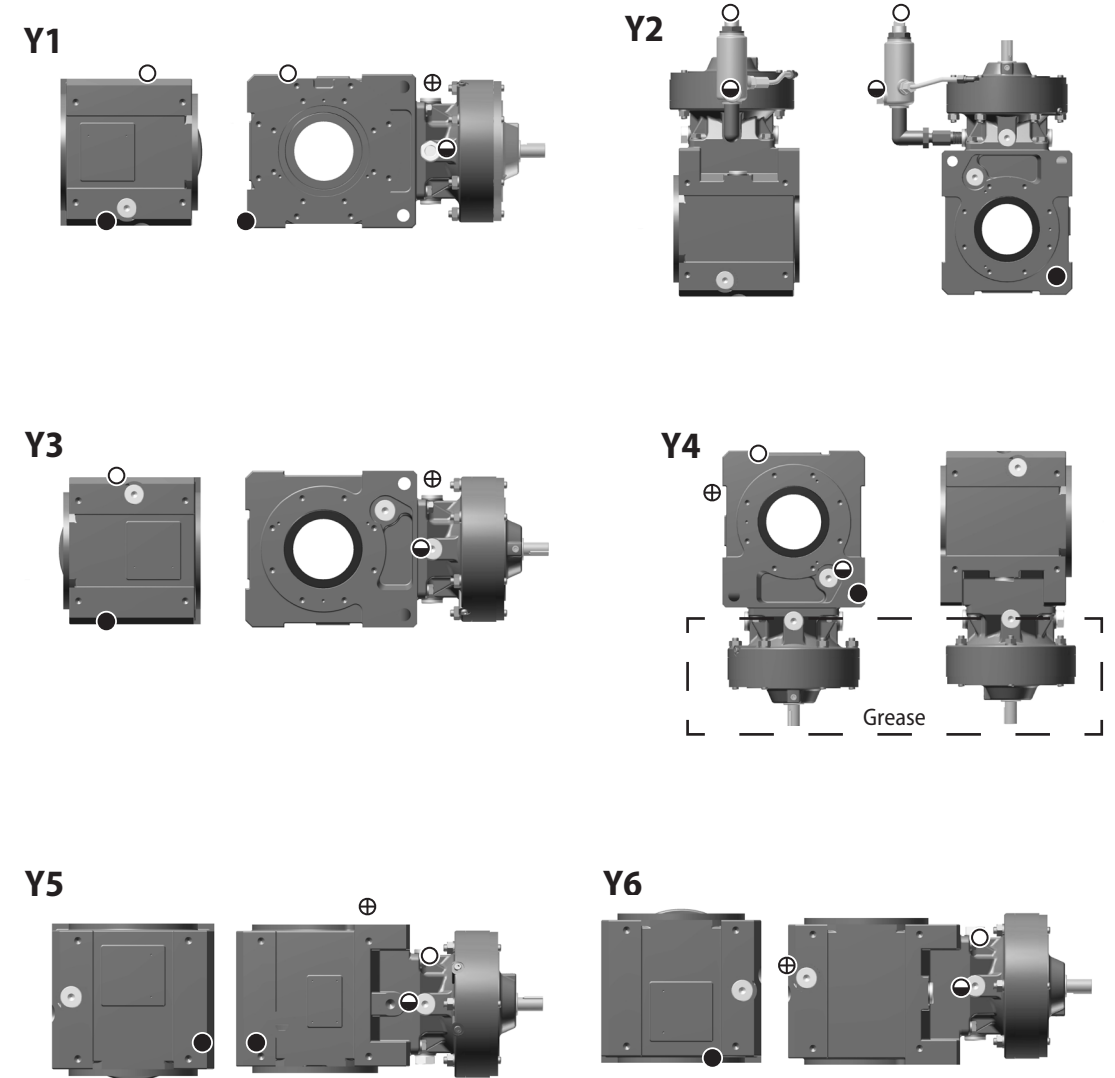

HBB Oil Fill Quantities

Table 22. Single Reduction Approximate Oil Quantity

Units: U.S. liquid gallon (*liter*) **Note: Output = Bevel Gear Portion Input = Cyclo®**

Helical Buddybox Size	Output				Input			
	Y1	Y2	Y3	Y4	Y1	Y2	Y3	Y4
AA, Z	0.16 (0.60)	0.16 (0.60)	0.13 (0.49)	0.16 (0.60)	Grease			
A	0.21 (0.80)	0.24 (0.91)	0.18 (0.68)	0.24 (0.91)				
B	0.26 (0.98)	0.40 (1.51)	0.26 (0.98)	0.40 (1.51)				
C	0.45 (1.70)	0.55 (2.10)	0.34 (1.30)	0.55 (2.10)	0.11 (0.40)			
D	0.71 (2.70)	0.92 (3.50)	0.53 (2.00)	0.92 (3.50)	0.18 (0.68)			
E	0.92 (3.50)	1.11 (4.20)	0.66 (2.50)	1.11 (4.20)	0.24 (0.90)			

Oil Plug Locations

○ Oil filler plug ● Oil level (Oil gauge) ● Oil drain plug

Floor-All Positions

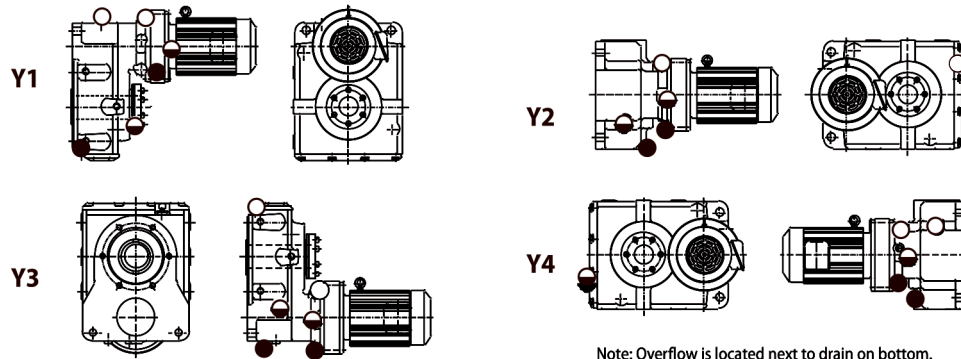

Note: Overflow is located next to drain on bottom.

Start-Up

Check the following under no load prior to start-up:

- Be sure the Cyclo® reducer is filled with the correct amount of approved oil or grease.
- Ensure that the driven load and the Cyclo® reducer or gearmotor are properly secured.
- Verify the rotation direction of the electrical motor before connecting it to the load. Motor rotation direction can be reversed by swapping any two of the motor power connections.
- Verify motor current imbalance does not exceed 10%.
- After unit comes up to speed, verify the motor current (average of all three motor leads) matches the motor nameplate full load ampere rating +/- 10%.
- If after applying power to the motor, the unit will not come up to full speed, takes an unusually long time to come up to full speed, or makes an abnormal sound, immediately disconnect the power and consult the factory.

Long Term Storage Procedure



Caution: Consult the factory before operating units stored for periods longer than one year or for additional details.*

Preparation for Six Months to One Year Storage

- Fill Shell VSI Circulating Oil 100 to 5% of required lubricating oil volume and tightly seal airflow opening (i.e., replace breather with plug). For extended storage, Circulating Oil must be changed every year.
- **Grease lubricated** models are filled with grease prior to shipping and do not require additional lubricant during long term storage.
- Operate the unit every 2 or 3 months after delivery by hand while ensuring a minimum of one and a half rotations of the output shaft.
- Consult the factory for storage procedures if you plan to store your unit for longer than one year.

Operation After Six Months to One Year Storage

For **oil lubricated** units:

- ~Completely drain the rust preventive or circulating oil from the unit.
- ~Flush the unit with the recommended operating oil.
- ~After flushing, fill the unit with the correct quantity of recommended oil.
- ~Follow the steps listed in the Start-up section of this document before operating.

After Six Months to One Year Storage

- **Grease lubricated** units do not require any special procedures following storage, however, you should follow the steps listed in the **Start-up** section of this document before operating.

*For additional Long Term Storage Information, please refer to our Long Term Storage Procedure on our website.

Preparation for electrical motor storage

- If possible, store indoors in an area that is clean and dry.
- Cover the motor completely with plastic or a weather-proof tarp.
- Allow for adequate ventilation to ward off the formation of condensation.
- If condensate plugs or drain plugs are installed, ensure they are functional.
- If the motor is equipped with a motor space heater, ensure it is properly connected and able to maintain the motor's interior temperature at least 5.6°C above ambient.
- Protect motor from flooding or exposure to harmful chemical vapors.
- Ensure storage area is free from vibration or lock motor shaft to prevent movement.
- Turning the motor's rotor every month is recommended to redistribute the lubricant in the bearings.

Operation

- If condensation does occur, allow the motor to dry thoroughly before applying power.
- Test motor insulation resistance for a minimum value of 10 megaohms.

Headquarters & Manufacturing

◆ Sumitomo Machinery Corporation of America

4200 Holland Boulevard

Chesapeake, VA 23323

Tel: +1-757-485-3355 • 1-800-SMCYCLO

Fax: +1-757-485-7490

www.sumitomodrive.com

E-mail: sma.customerservice@shi-g.com

After Hours Technical Support

sma.service@shi-g.com

1-800-983-1000

Quick Start Guide

Cyclo®, *BBB4*, *BBB5*, *BBBH*, *HBB*, *Hyponic®*

World Headquarters

Japan

Sumitomo Heavy Industries, Ltd.

Power Transmission & Controls Group

ThinkPark Tower, 1-1, Osaki 2-chome,

Shinagawa-ku, Tokyo 141-6025 Japan

Tel: +81-367-37-2511 • Fax: +81-368-66-5160

For facilities located in the Americas, please visit

www.sumitomodrive.com/locations

For worldwide locations, please visit

www.sumitomodrive.com/worldwide

www.sumitomodrive.com

1-800-SM-CYCLO