

WHITE PAPER

How to Select the Right Speed Reducer For Your Mixer Application

Chris Casimir

Sumitomo Drive Technologies

 Sumitomo Machinery Corporation of America

Contents

Introduction..... 3
 Converting Inputs: Goes in Good, Comes Out Better 3
Supporting Your Needs: The Backbone for Your Mixer 4
Stress Relief: Taking the Weight Off the Shoulders of the Reducer..... 7
Lifespan: A Mathematically Calculated Destiny 7
Each Mixer is Unique: There's a Perfect Match for Everyone 9
When enough is too much: Preventing overload failures..... 11
Option Packages: Tailored Fits for Your Application 11
Taking the next step: Requesting a reducer quote:..... 14
References: 15

Introduction

When upgrading or installing a new mixer application, one of the many critical components is the speed reducer, which is installed between the motor and the impeller shaft.

The speed reducer, also referred to as the gearbox or torque increaser, plays many important roles in the system simultaneously. As the name implies, the reducer converts the motor speed to a more desirable operating speed for the mixer. Also, at the same time, the speed reducer increases the torque available to the impeller shaft. Both these operations occur simultaneously and are products of the mechanical advantages created by gearing systems. Furthermore, the speed reducer often acts as a support for the impeller shaft as a result of the connection between the low speed shaft of the gearbox and the impeller shaft.

Converting Inputs: Goes in Good, Comes Out Better

Electric motors are the prime mover of choice in many industries and are designed in such a way that their efficiency is based on running at their nominal rated speed. For 60hz motors, the nominal speed is either 1,200 rpm or 1,800 rpm; however, typical operating speed for mixers is



Figure 1- Typical Mixer Application

much lower. This is where the reducer makes things happen. By channeling the motor's output through a speed reducer, the gears interact with one another to decrease the speed of the impeller to a more practical level for the system. The output speed is directly related to the input speed and the gear ratio of the reducer, as indicated by

Formula 1: Output speed (n_{out}), based on input speed (n_{in}) and gear ratio (i): For a given nominal input speed, in order to decrease the output speed, the ratio of the reducer must decrease.

$$n_{out} = \frac{n_{in}}{i}$$

Even with the output speed at a desired level, the torque required to move the impellers blades through the medium in the tank is going to exceed the amount of torque generated by the induction windings in the motor and the mixer may never even begin rotating. The reducer therefore also functions as a torque multiplier to increase the output torque according to *Formula 2*:

Formula 2: Output torque based on input torque and gear ratio

$$T_{out} = T_{in} \cdot i$$

An example of the gearing advantage is shown below:

$$n_{in} \approx \text{Motor Speed} \approx 1,800\text{rpm}$$

$$T_{in} \approx \text{Motor Torque} \approx 525.2 \text{ in} \cdot \text{lbs}$$

$$\text{Gear Ratio} \approx 100 : 1$$

$$n_{out} \approx \frac{1,800\text{rpm}}{100 : 1} \approx 18\text{rpm output speed}$$

$$T_{out} \approx 525 \text{ in} \cdot \text{lbs} \times 100 : 1 \approx 52,520 \text{ in} \cdot \text{lbs}$$

In this example, by installing a reducer with a 100:1 gear ratio, the speed of the impeller was brought down to 18 rpm while the rotating torque applied to the impeller was increased to 52,520 in·lbs.

Supporting Your Needs: The Backbone for Your Mixer

In many mixer applications the reducer also acts as a key support for the entire system. *Figure 2* shows a common mounting configuration where the impeller shaft is rigidly coupled to the low speed shaft (LSS) of the reducer, meaning that the two are joined together almost as if the impeller shaft were an extension of the reducer.

This means that the reducer must be able to handle the hanging weight of the impeller shaft and blades - the combination of which can be quite substantial. Sometimes, the loads generated by the impeller blades moving through the mixing medium can be very significant. When torque is applied to rotate the impeller, the tip of the impeller will start to distort and move away from the central axis about which it spins. When such bending occurs, radial loads are transmitted into the reducer's shaft and bearings. This occurrence is shown in an exaggerated form in *Figure 3* (next page).

Radial loads, which could be small or large, are multiplied with the distance at which they occur from the closest bearing to produce the bending moment acting on the shaft of the reducer. Because impeller shafts can also range from very small to tens-of-feet, bending moments can become exceedingly large if either the radial load or the distance at which it is applied is large. Furthermore, impeller blades are often located at the ends of the impeller, thus making the impeller shaft length almost directly related to the bending moments. Simply put, as the impeller shaft length increase, so does the bending moment on the shaft. Large bending moments can be detrimental to reducers as the stresses that they create on the reducer's bearings, housings, gearing and shafts can very quickly lead to degradation and component failure. These can include, but are not limited to oil leaks, bearing failures, cracked

Figure 2 – Weight and loads on impeller shaft and blades are supported entirely by the

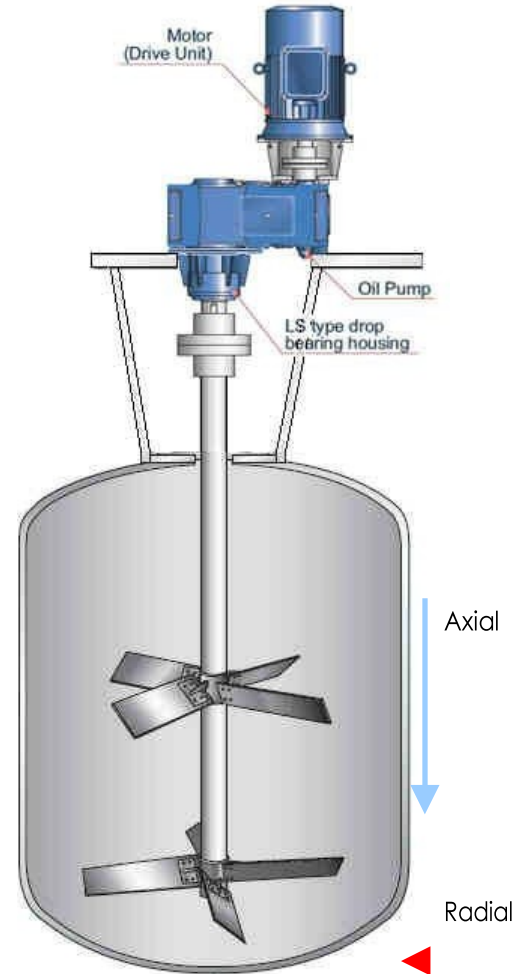

housings, damaged teeth, and/or snapped reducer low speed shafts.

Figure 3. Deflection due to radial load

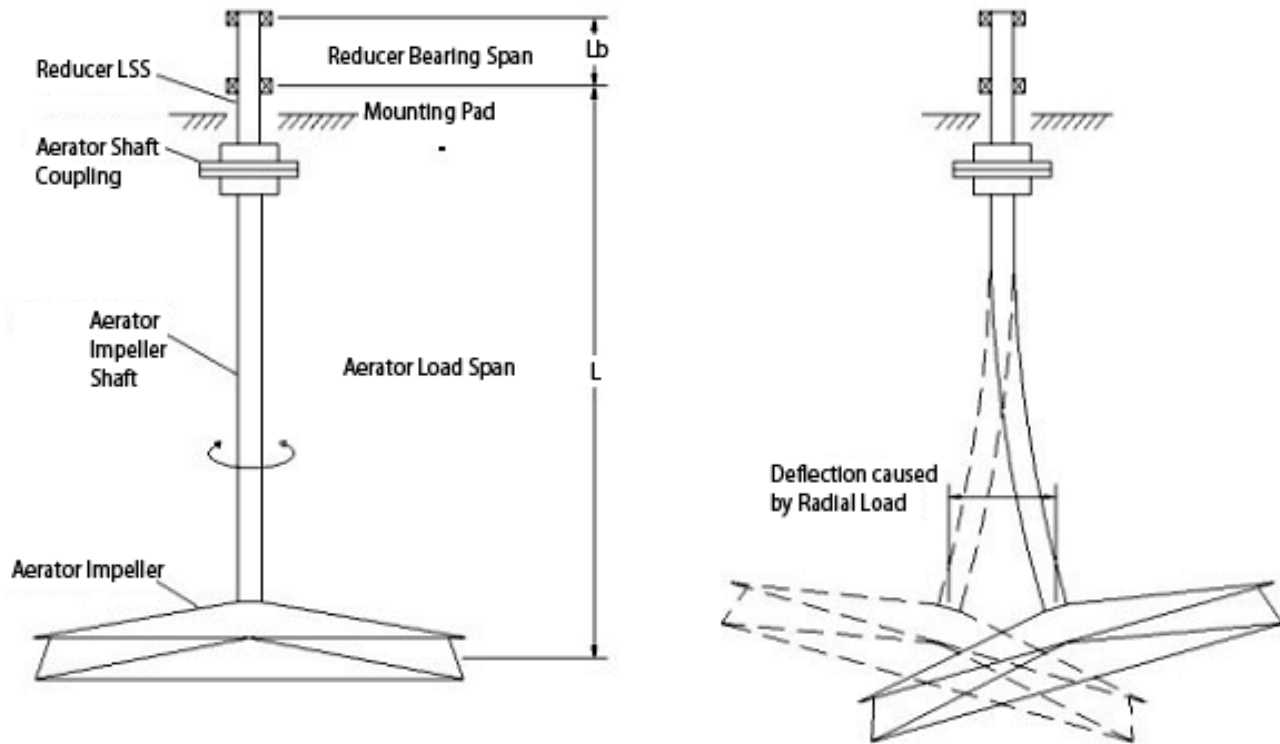

Complicating the stresses on the reducer even further are the axial or thrust loads generated when the impeller blades rotate. The mixer blade's angled surface moving through a medium will generate forces that push the blades and shaft up or try to pull the impeller down. These thrust loads combine with the gravitational load of the impellers weight and are absorbed by the bearings and housings of the reducer. Depending on the combination of radial and axial loads, different bearings may be required. Some bearing types are better suited for pure thrust loads and others are designed to accommodate pure radial loads. If there will be a moderate combination of both thrust and radial loads, yet another bearing type would be appropriate.

Figure 4: Radial and axial forces acting on the impeller are transmitted into the reducer

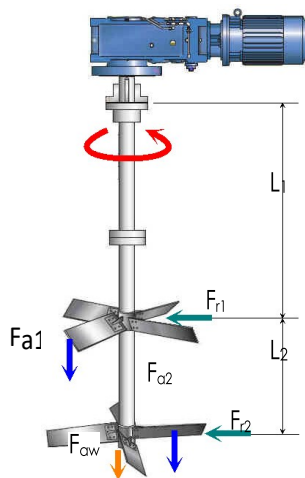

Calculating the total loading on the system can be done according to the following diagram and

Formula 3: Resultant force F_r acting on the

$$\text{Radial Load: } F_r = \sqrt{F_{r1}^2 L_1^2 + F_{r2}^2 L_1^2 L_2^2 + \frac{1}{2} L_2^2 L_1}$$

Formula 4: Summation of forces in the axial

$$\text{Axial Load: } F_a \quad \text{where: } F_a = F_{a1} + F_{a2} + F_{aw}$$

Stress Relief: Taking the Weight Off the Shoulders of the Reducer

When the reducer is left to handle all overhung loads on its own, the result could be a much larger gearbox than would be necessary for reducing the output speed and generating enough rotating torque alone. When talking reducer sizing, it is not uncommon for an application's demands to increase the standard reducer selection 2, 3 or even 4+ unit sizes just to handle the overhung loads. When increasing that much, the mechanical service factor can end up being double or triple the motor's nameplate power level. This is the result of stouter components sized to handle the loads of the mixer application. Gear teeth need to be bigger, thicker and stronger. Likewise, the low speed shaft diameter may need to increase substantially to keep from twisting apart. The end result of this otherwise over-sized behemoth of a speed reducer: Increased component cost including the reducer, couplings, and accessories. Not only will upfront costs start to skyrocket with increasing overhung loads, but also spare parts and maintenance fees down the road will increase as well as a result of the bigger parts. In addition, job sites become more cramped as the larger size reducers take up more space.

One way to combat this overgrowth is to select and install mixer systems that have been designed to limit overhung loads acting on the impeller shaft. Bearing supports installed along the impeller shaft can constrain the shaft to rotation only about the desired axis, thus eliminating or reducing the presence of radial and thrust loads. In the case of a double bearing supported impeller shaft, the system would have bearings installed specifically to handle the loads generated leaving the reducer to do what it is best at: Reduce speed and increase torque. With this shaft supported configuration, the reducer's LSS and the impeller would then benefit from a flexible torque only connection - the two now free to rotate together but allowing each to carry only their own loads. This enables a smaller, more cost effective gearbox to be installed and, most likely, to continue working problem free for many years to come.

The other option is to ensure that the reducer has been selected to handle everything expected of it. By sizing the box correctly and equipping it with the appropriate features and options, the reducer will hardly break a sweat under even the worst of conditions. These options can include extended bearing spans; drop bearings, specialized bearings for certain loads and more. Each option will likely result in a price increase for the drive assembly but may result in a lower net system price than external bearing supports. The one major concern when tailor fitting a reducer to deal with the stresses of a mixer application is verifying that all dynamic axial and radial forces have been taken into account. Experience has shown that some forces are quite difficult to calculate or plan for and thus OEM's often request units with component ratings much higher than those found in other industries.

Lifespan: A Mathematically Calculated Destiny

When specifying the requirements for a reducer, more often than not someone wants assurance that their reducer will perform long enough to pay for itself and prove to be a solid investment. After all, the entire weight of the application could be resting on the reducer's shoulders. As a result of the unique nature of the application, having high radial and/or thrust loads, bearing life is often used to dictate required the run time for a reducer.

In the wastewater treatment industry, bearing life requirements of 150,00 to 250,000 hours are not uncommon whereas 60,000 to 100,000 may be all that is necessary in other non-mixer industries. According to the International Organization for Standardization (ISO) and the American Bearing Manufacturers Association (ABMA) L-10 bearing life is defined as *"the life that 90% of a sufficiently large group of apparently identical bearings can be*

expected to reach or exceed.”¹

Several mathematical formulas exist for estimating bearing life, ranging from quick and simple rules of thumb to complex or lengthy formulas that incorporate operation criteria such as oil cleanliness and are very sensitive to changes in loading or ambient conditions. As such, any experienced reducer manufacturer should be able to provide calculated estimates for L-10 bearing lives on all reducer bearings. Two bearing life formulas are shown below:

Formula 5: Simple bearing life formula is good for quick estimations and as a rule of thumb.

$$L_{10} = \left(\frac{C}{P} \right)^3 \times 5,000 \text{ hours}$$

C □ Reducer Mechanical Rating
 P □ Motor Power

Formula 6: For more exact bearing life estimates, the latest ISO bearing life formula will provide better accuracy, however, will be more sensitive to application conditions.

$$Lna = a_1 a_2 a_3 \left(\frac{C}{P} \right)^p$$

Lna □ Adjusted rating life

C □ Basic dynamic load rating (N). (Cr for radial bearings and Ca for thrust bearings)

P □ Bearing load (dynamic equivalent load) (N) Pr for radial, and Pa for thrust bearings

p □ 3 for ball, 10/3 for roller bearings

a_2 □ Material Factor

a_1 □ Reliability Factor

a_3 □ Application conditions Factor

One thing to note with high bearing life requirements is that as the number of required hours increases, so too will the size of the box and the mechanical service factor. It would be beneficial to weigh the added cost of a longer life from an over-sized reducer against the cost savings for a more reasonable bearing life on a unit sized appropriately for the loads and conditions.

Each Mixer is Unique: There's a Perfect Match

Just as mixers come in several varieties, including vertical, horizontal, screw type, aerators, agitators, etc., reducers do as well. Choosing the correct reducer for your mixing application depends on the application's characteristics. Each mixer may have one or more reducer configuration that is well suited to get things turning.

Parallel reducers permit narrow installations by installing the drive motor parallel with the impeller shaft. *Figure 2* and *Figure 5* shows parallel units, mounted horizontally with the input and output shafts of the reducer vertically aligned. With the motor installed atop the reducer, floor space is conserved and the overall footprint of the drive package is kept low. This particular design allows for

larger bearing spans than concentric or inline reducers by offsetting the input and output shafts and allows for multiple gear sets to be used.



Figure 5. Parallel reducer installed above an impeller shaft with a flange-mounted motor connected to the top of the reducer via a motor lantern.

Right angle reducers can be used when the drive configuration doesn't allow for tall assemblies. Instead, the motor will be installed adding to the length of the reducer, rather than the height. Right angle reducers can also benefit from wider bearing spans than those found in concentric reducers. *Figure 4 on Page 4* shows a right angle drive configuration.

In-line or concentric reducers put all the components along the same axis as the impeller shaft. While this design can be very compact and consume very little floor space, they are tall and standard concentric reducers suffer from small bearing spans. In a Sumitomo Cyclo® speed reducer, as well as most planetary reducers, the input and output shafts are in-line with each other and have bearings that are very close to one another. Their design, therefore, dramatically limits the amount of overhung loads they are capable of encountering. In supported systems, however, where overhung loads are low, concentric reducers are a very economical choice. Available ratios can range from ~3:1 to well over 5000:1; making concentric reducers capable of monstrous torque and incredibly low output speeds. *Figure 6* shows a vertical Cyclo® concentric reducer ready for installation



Figure 6: Vertical Cyclo® Speed Reducer is mounted to a base, waiting to be installed atop a clarifier



Figure 7: The same unit now installed at the center of a large clarifier tank

When enough is too much: Preventing overload failures

One concern to any rotating application is the introduction of sudden load spikes. Whether this is in the form of jams, unwanted foreign debris or very thick mediums, protecting mixing equipment from failure is always a good investment in the long run.

Protection devices can come in various forms. Most common would be torque-limiting devices and overload switches. A torque-limiting device can be a simple mechanical device like a shear pin designed to fail at a certain torque level, a torque limiting coupling that introduces slip in the driveline beyond desired torque value, or a torque limiter built into the speed reducer itself. Overload switches can be used to interrupt power to drive motors upon sensing an overload condition. An example of the later can be seen in *Figure 8*.

Another commonly overlooked method of dealing with momentary overloads is to purchase products durable and rugged enough to handle occasional torque spikes. Some reducers, such as the Cyclo[®] offer a 500% momentary torque rating, meaning that the reducer can handle a momentary peak load 5x the normal rated torque without breaking.



Figure 8. This Cyclo[®] speed reducer by Sumitomo Drive Technologies is equipped from the factory with an optional torque limiter wired into the systems control circuitry to shut the system down when overload occurs. The analog gauge provides jobsite personnel with a quick and easy access view of the loading conditions while the unit is in operation.

Option Packages: Tailored Fits for Your Application

Many manufacturers will offer optional accessories and components with their reducers, but which options are needed and why?

Drop Bearings or *Extended Bearing Spans* may be one of the most offered options in industrial mixing applications. The drop bearing will allow the manufacturer to alter the internal bearing span of the reducer by bolting on an additional structure to the low speed shaft section of the housing and installing a bearing further away from the other. This is critical in circumstances where the impeller shaft is long or the radial load is great. The extended span allows the bearings to better deal with the large bending moment and can also allow for the housing to be reinforced as well. Though drop bearings and extended bearing spans can be expensive, they provide the only true alternative to upsizing the gearbox or designing a custom unit for the application, both of which have the potential to significantly increase the cost. *Figure 9* shows that by increasing the bearing span, reactive forces acting on each bearing are decreased.

Figure 9. A standard bearing span on the left compared to an extended bearing span on the right. The larger the distance between bearings, the better the overhung load capacity

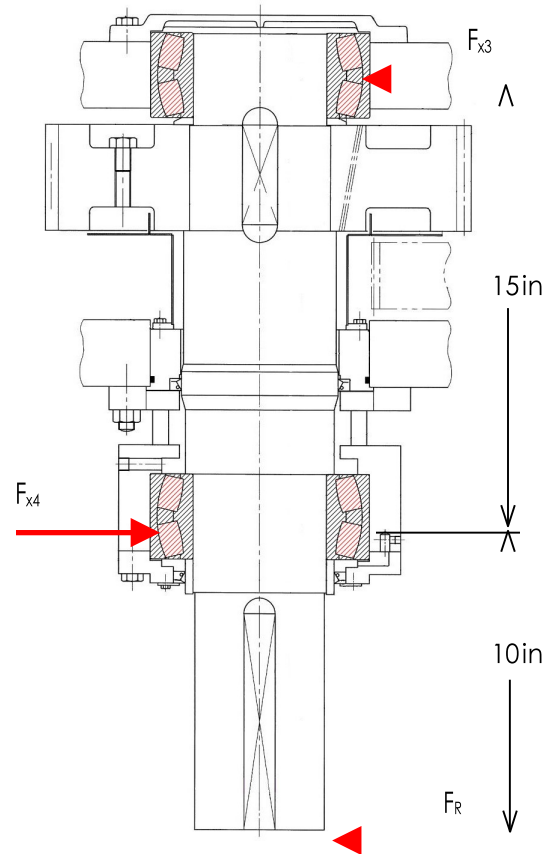
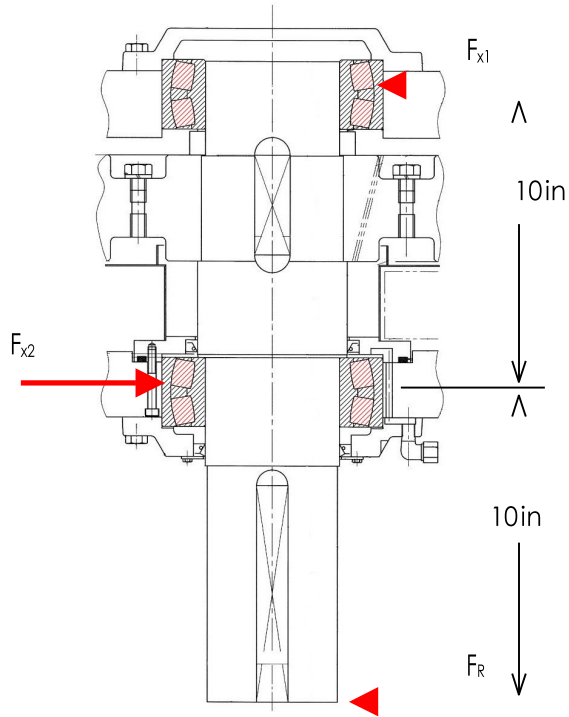

$$\begin{aligned} M_X &= 0, & F_X &= 0 \\ F_R &= 100 \text{ lbs} \\ M_X &= F_{X1} \cdot 0 + F_{X2} \cdot 10 + F_R \cdot 20 = 0 \\ & F_{X1} \cdot 0 + F_{X2} \cdot 10 + 100 \cdot 2,000 = 0 \\ F_{X2} &= 10 \cdot 2,000 \\ r &= F_{X2} = 200 \text{ lbs} \\ F_X &= -F_{X1} + F_{X2} + F_R = 0 \\ -F_{X1} &= 200 - 100 = 0 \\ F_{X1} &= 100 \text{ lbs} \end{aligned}$$

$$\begin{aligned} M_X &= 0, & F_X &= 0 \\ F_R &= 100 \text{ lbs} \\ M_X &= F_{X3} \cdot 0 + F_{X4} \cdot 15 + F_R \cdot 25 = 0 \\ & F_{X3} \cdot 0 + F_{X4} \cdot 15 + 100 \cdot 25 = 0 \\ F_{X4} &= 15 \cdot 2,500 \\ r &= F_{X4} = 167 \text{ lbs} \\ F_X &= -F_{X3} + F_{X4} + F_R = 0 \\ -F_{X3} &= 167 - 100 = 0 \\ F_{X3} &= 67 \text{ lbs} \end{aligned}$$

Forced Lubrication Systems are regularly offered in reducers that have vertical shafting due to the need for oil routing to upper bearings. Forced lubrication systems are also frequently offered on drives which are to be mounted at an incline. Even minor changes to the angle of installation alter the oil level inside the reducer and subsequently the effectiveness of the lubrication system. *Figure 10* below shows a common screw pump configuration with parallel shaft reducers mounted on a considerable incline.

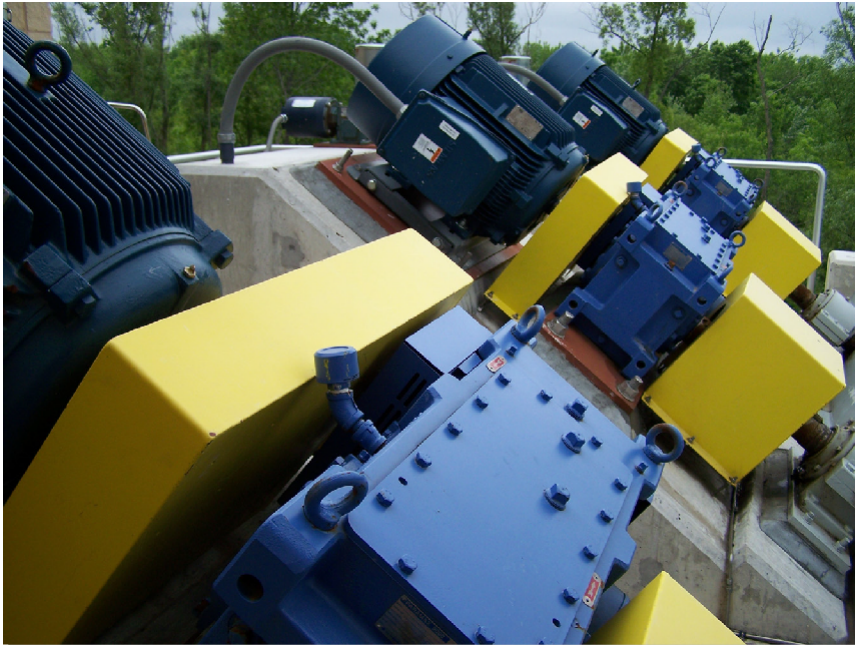

Drywells for the LSS of reducers effectively block oil from reaching the seals and are designed to be a safeguard against seals from leaking and contaminating the mixing medium. Instead of using the regular oil to lubricate the lower bearing on a vertically downward LSS, the lower bearing will be grease lubricated. It is good peace of mind for many industries concerned with contamination and environmental regulations.

Figure 10: Screw pump applications require a 38° angle of inclination.

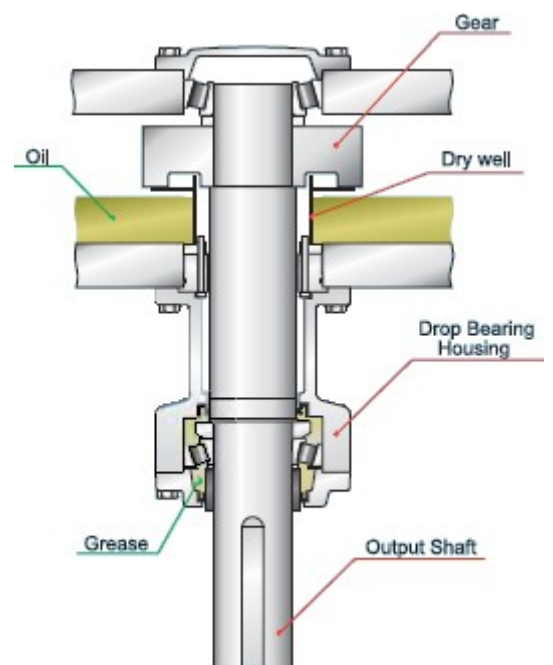

Figure 11. Drywells provide a barrier to separate the reducer's LSS from the oil. This coupled with grease lubricated lower bearing decreases the chance of oil leaking past the low speed seals on the reducer and contaminating the mixing medium.

Taking the next step: Requesting a reducer quote:

Now that the unique characteristics of mixers have been explained, finding the right reducer for your application should be a little less confusing. To request a bid from the local power transmissions distributor or speed reducer manufacturer, a little bit of knowledge can go a long way in speeding up the selection or quotation process. By knowing system requirements are, you can save valuable time and money by selecting the right gearbox to efficiently run your application.

Below is a quick reference list of system information used by Application Engineers that will be considered when making a selection.

1. Input Power
2. Input Speed
3. Desired Output Speed
4. Run Time
5. Installation Environment:
 - a. Ambient Temperature
 - b. Site Elevation
 - c. Indoor/Outdoor
 - d. Atmospheric Conditions
6. Space Envelope
7. Installation Angle
8. Minimum L-10 Bearing life
9. Overhung loads:
 - a. Radial Load
 - b. Thrust Load
10. Impeller Shaft Length
11. Impeller Shaft Supports
12. Mixing Medium
13. Expected Overload Conditions
14. Special Options and Accessories

When in doubt of your system requirements, consult with the mixer's original manufacturer. For existing installations, much of the information can often be found in either the Owner's Operation & Maintenance manual or in the system's certified drawings.

References:

1. "How long will a bearing last? Standardized life equations help to answer." Daniel R. Snyder, P.E. ,
<http://machinedesign.com/article/the-meaning-of-bearing-life-0412>
 2. Bearing life calculations from Nachi Bearings
<http://nachi-tool.jp/bearing/pdf/Tech.pdf#view=Fit>
 3. Four Design Types for AC Induction Motors
<http://www.inverter-china.com/blog/upload/torque-speed-curve-of-different-nema-standard-motors2.jpg>
-

