

***RIGHT*** FOR FOOD AND BEVERAGE

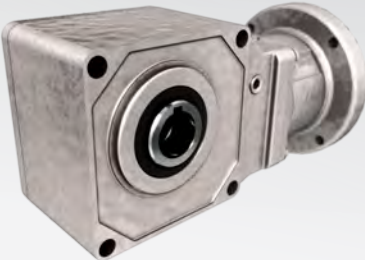
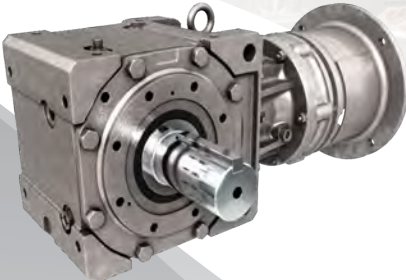

## Introducing Food and Beverage Protection Packages

### SHIELD360°™

As governing sanitation bodies such as USDA, FDA, NSF, and 3-A recommend higher levels of bacteria control in food and beverage handling environments, there is an industry-wide increase in the chemical concentration, water temperature, and frequency with which facilities are cleaning their respective equipment.

Given this greater focus, it is critical that all equipment utilized within a food handling facility be capable of withstanding long-term exposure without external degradation or compromise in performance.

Recognizing this, Sumitomo Machinery Corporation of America is excited to introduce the **SHIELD360°™** family of protection packages. From general-purpose solutions to those geared to harsh, high-pressure wash-down environments, Sumitomo has a response that will meet your most stringent demands.

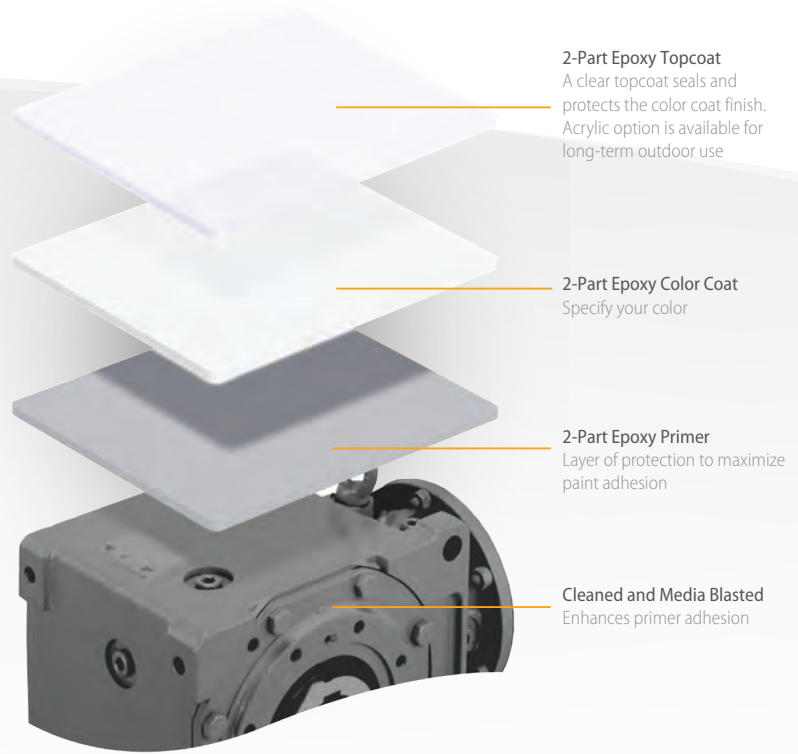

## QUICK SHIPPING SOLUTIONS

### Quick SHIELD express shipping

Sumitomo Machinery Corporation of America now offers same day, 1-day and 2-day shipping on many of our SHIELD360°™ family of packages. For more information about Quick SHIELD, please consult the factory or your Sumitomo representative.

### Standard Colors



FDA Sumitomo White



FDA Stainless Steel



FDA Silver Freeze



Primer Only





## SHIELD<sup>360°</sup>

- Excellent gloss and color retention for outdoor use
- Acceptable protection from splashing water but not continuous exposure
- NSF H1 food grade lubricant, FDA 21 CFR compliant (synthetic for hyponic)
- Topcoat has limited resistance to hydrocarbon solvents and oils (extended use)
- Does not include any stainless steel parts
- FDA Sumitomo White color standard

IP 54



## Micro SHIELD<sup>360°</sup>

EXCLUSIVE TO HYPONIC

- NSF 51 Certified, Powder Coat
- Antimicrobial topcoat
- Acceptable protection from splashing water but not continuous exposure
- Excellent gloss and color retention for outdoor use
- NSF H1 food grade synthetic lubricant, FDA 21 CFR compliant
- Includes stainless steel option
- FDA Silver Freeze color standard

IP 54



## Chemi SHIELD<sup>360°</sup>

- Excellent gloss and color retention for outdoor and chemical use
- Acceptable protection from water, including water sprayed from a nozzle onto the enclosure
- Topcoat has limited resistance to hydrocarbon solvents & oils (extended use)
- Includes stainless steel option
- FDA Stainless Steel Gray color standard

IP 55



## Ultra SHIELD<sup>360°</sup>

- Excellent resistance to common cleaning and sanitizing compounds used in the Food & Beverage industry as long as chemicals are mixed per the manufacturer's recommendation
- Complete protection for the enclosed equipment from dust and other materials such as dirt, oils and non-corrosives
- System has a high level of protection from water, including powerful jet sprays used during washdown
- NSF H1 food grade lubricant, FDA 21 CFR compliant (synthetic for hyponic)
- Not recommended for long-term outdoor use
- Includes stainless steel option
- FDA Stainless Steel Gray color standard

IP 65



## FOOD GRADE SEALING SOLUTIONS

The harsh duty cassette seal is an antimicrobial FKM material molded over a 304 stainless steel sleeve and case. It has a multi-lipped self-contained and self-sealing design. The spinning action of the seal functions as a flinger, using centrifugal force to expel contaminants from the seal elements.

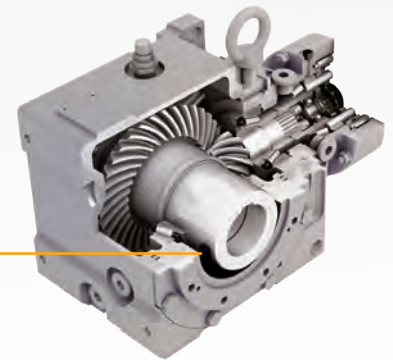

## MARATHON POWERWASH™ MOTOR SHOWCASE

All stainless steel, totally enclosed

- Suitable for use of VFD 10:1 Variable torque, 10:1 (TEFC) or 1000:1 Constant Torque
- MAX GUARD Class F insulation system
- 1.15 Service Factor on sinewave, 1.0 Service Factor on IGBT power
- Double sealed ball bearings
- 303 stainless steel shaft with spring-loaded contact seals in each end. (Drive end only on TENV.)
- 300 Series Stainless Steel external construction: frame, endshield, conduit box, mounting base, and hardware for superior corrosion resistance
- Internal corrosion-resistant coatings on rotor, and heavy polyester varnish on stator
- 100% paint-free construction
- One-way condensation drains in each endshield and conduit box for all angle mounting
- Nitrile Buna-N gaskets and seals on conduit box, through bolts, and endshields
- Rated 60/50/hertz, 190/380 volt an next lower horsepower
- Nameplate information laser-etched on frame
- UL recognized, CSA certified, and CE marked

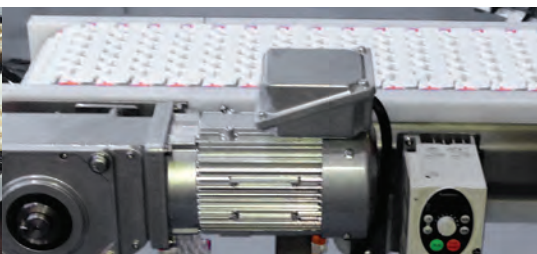

## HYPONIC® Quill Frame Size Details\*

Frame Size	POWER		BORE RANGE	
	Max Torque lb·in	Max Motor Power HP	Keyed Hollow Shaft inch	Shrink Disc inch
1120	246	¼	¼	¼
1220	492	½	1	1
1230	868	⅛	1	1
1320	985	1	1 ⅛ - 1 ¼	1 ⅛ - 1 ¼
1330	918	¼	1 ⅛ - 1 ¼	1 ⅛ - 1 ¼
1420	1970	2	1 ¼ - 1 ⅞	1 ¼ - 1 ⅞
1430	1970	½	1 ¼ - 1 ⅞	1 ¼ - 1 ⅞
1530	3940	1	1 ⅜ - 1 ¾	1 ⅜ - 1 ¾

\* Consult factory for metric shaft sizes and additional unit sizes

**Unique Sealing Arrangements**  
Multiple lip, harsh duty, and food grade designs available to prevent leaks

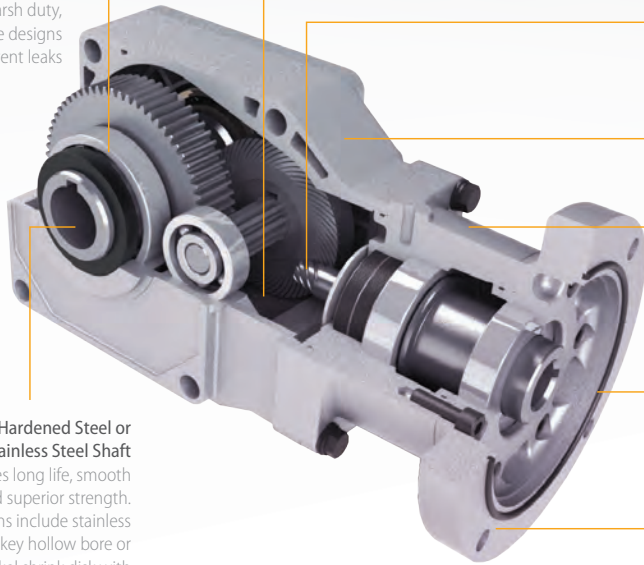

**Lubricant**  
NSF H1 grade synthetic grease

**Highly Efficient**  
Long-lasting hypoid gearing delivers efficiencies up to 85% and smooth, quiet operation

**High Quality, Smooth Housing**  
Aluminum housing affords lighter, more manageable packages while significantly increasing thermal ratings and lubricant life

**Mounting Versatility**  
Suitable for universal mounting in any orientation without modifications

**O-Ring**  
Quill O-ring prevents water intrusion

**C-Face Quill**  
Supported by two bearings for long life, the quill-style motor adapter allows for maximum motor flexibility

**100% Hardened Steel or 304 Stainless Steel Shaft**  
Provides long life, smooth operation, and superior strength. Shaft options include stainless steel key hollow bore or electroless nickel shrink disk with stainless steel hub

## HYPONIC®

Compact right angle gearbox with patented all-steel HYPONIC® gear technology, maintenance-free grease lubrication, high-efficiency operation, and universal mounting.

- **Torque Capacity:**  
44 to 13,100 lb·in (5 to 1,480 N·m)
- **Power:**  
1/8 to 15 HP (0.09 to 11.1 kW)
- **Ratio Range:**  
5:1 up to 1440:1



Shrink Disk with Integral Motor

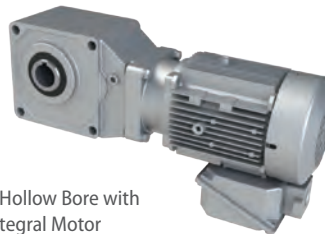

Keyed Hollow Bore with Integral Motor

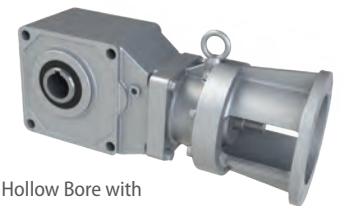

Keyed Hollow Bore with NEMA C-Face



## CYCLO® Bevel BUDDYBOX® 4 Series Quill Frame Size Details\*

Frame Size	POWER		BORE RANGE		
	Max Torque lb-in	Motor Power Range HP	Shrink Disc inch	Keyed Hollow Shaft inch	Solid Shaft** inch
Size A	9,470	1/2 - 25	1 15/16 - 2 3/16	1 15/16 - 2 3/16	2
Size B	18,851	1/2 - 40	2 3/16 - 2 7/16	2 3/16 - 2 7/16	2 7/8

\* Consult factory for metric shaft sizes

\*\* Consult factory for availability

BBB 4

### CYCLO® Bevel BUDDYBOX® 4 Series (BBB4)

Right angle, hardened steel, spiral bevel speed reducers with CYCLO® or planetary reducer inputs. Features rugged ductile iron housing with multiple output configurations.

- **Torque Capacity:**  
1,088 to 159,983 lb-in  
(123 to 17,400 N·m)
- **Power:**  
1/8 to 100 HP (0.10 to 60 kW)
- **Ratio Range:**  
11:1 to 26,000:1 and greater

**Filtered Breather**  
Protects unit lubrication from contaminants. Wash down version available

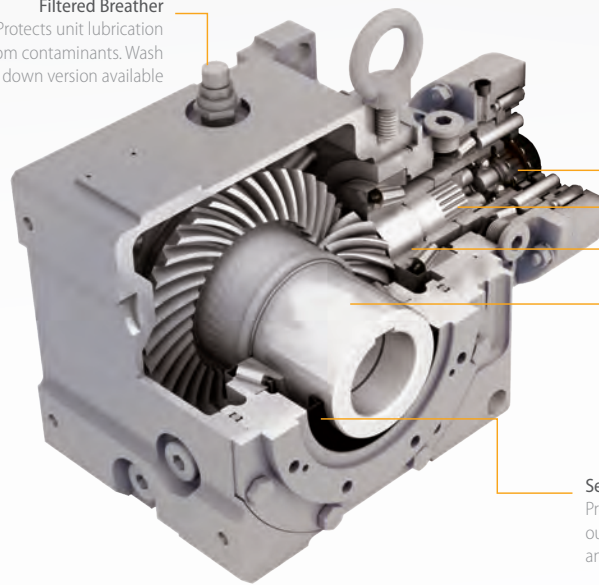

**CYCLO® or Planetary Input**  
Provides high overload capacity and exceptional reliability

**Unique Splined Connection**  
Ensures more durable and dependable power transmission than typical keyed connections

**Tapered Bearings**  
Resist axial and radial loads simultaneously

**100% Hardened Steel or 304 Stainless Steel Shaft**  
Provides long life, smooth operation, and superior strength. Shaft options include stainless steel key hollow bore or electroless nickel shrink disk with stainless steel hub

**Seals**  
Prevent leaks and exclude contaminants. Tandem output seals for general applications. Harsh duty antimicrobial seals for high pressure environments



Screw  
Conveyor Drive

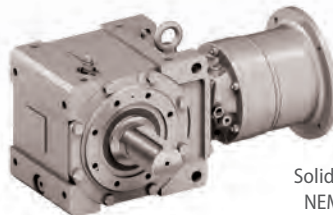

Solid Shaft with  
NEMA C-Face

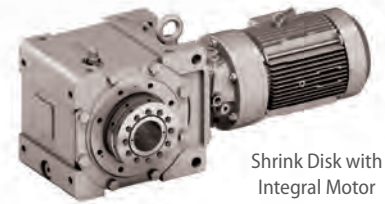

Shrink Disk with  
Integral Motor



## CYCLO® Bevel BUDDYBOX® 5 Series Quill Frame Size Details\*

Frame Size	POWER		BORE RANGE	
	Max Torque lb·in	Motor Power Range HP	Keyed Hollow Shaft inch	Shrink Disc inch
Size Z**	6,085	¾ - 15	1 ⅜ - 1 ¾	1 ⅜ - 1 ¾
Size A	9,470	1 - 25	1 ¼ - 2 ⅜	1 ¼ - 2 ⅜
Size B	18,850	1 ½ - 40	1 ⅜ - 2 ⅝	1 ⅜ - 2 ⅝
Size C	37,700	2 - 60	2 ⅜ - 3 ⅜	2 ⅜ - 3 ⅜

\* Consult factory for metric shaft sizes

\*\* Frame Size Z has a lightweight, die-cast aluminum housing design

**Filtered Breather**  
Protects unit lubrication from contaminants. Wash down version available

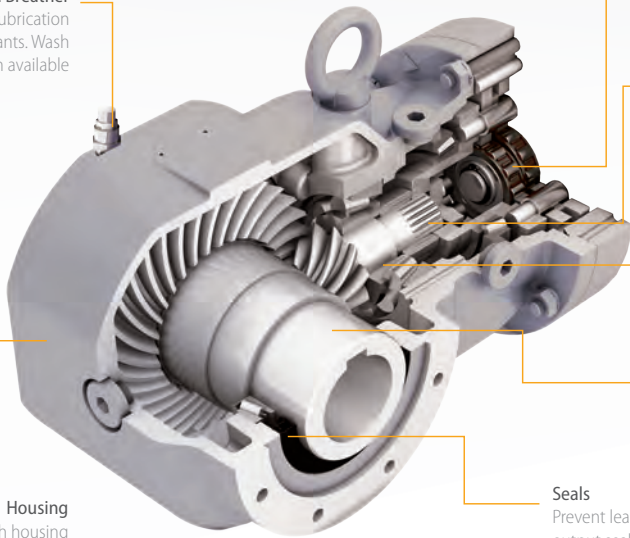

**CYCLO® or Planetary Input**  
Provides high overload capacity and exceptional reliability

**Unique Splined Connection**  
Ensures more durable and dependable power transmission than typical keyed connections

**Tapered Bearings**  
Resist axial and radial loads simultaneously

**100% Hardened Steel or 304 Stainless Steel Shaft**  
Provides long life, smooth operation, and superior strength. Shaft options include stainless steel key hollow bore or electroless nickel shrink disk with stainless steel hub

**Seals**  
Prevent leaks and exclude contaminants. Tandem output seals for general applications. Harsh duty antimicrobial seals for high-pressure environments

**Compact Housing**  
New smooth housing design is optimized for small mounting spaces

## CYCLO® Bevel BUDDYBOX® 5 Series (BBB5)

Right angle, hardened steel, spiral bevel speed reducers with CYCLO® or planetary reducer inputs. Optimized for shaft mounted applications.

- **Torque Capacity:**  
1,088 to 45,450 lb·in (123 to 5,140 N·m)
- **Power:**  
1/8 to 60 HP (0.10 to 45 kW)
- **Ratio Range:**  
11:1 to 26,000:1 and greater



Keyed Hollow Bore with NEMA C-Face



Keyed Hollow Bore with Integral Motor



Shrink Disk with Integral Motor



## CYCLO® 6000 Series Quill Frame Size Details\*

Frame Size**	POWER	
	Max Torque lb-in	Max Motor Power HP
606	213	¼
6065	266	¼
607	398	½
6075	531	½
608	527	¾
6085	632	1
609	1,330	1 ½
6095	1,770	2
610	2,210	3
6105	2,660	3
611	2,640	3

Frame Size**	POWER	
	Max Torque lb-in	Max Motor Power HP
6115	3,030	5
612	4,600	5
6125	5,570	7 ½
613	6,900	10
6135	8,320	15
614	10,900	15
6145	12,200	20
616	15,500	25
6165	18,600	30
617	22,400	35
6175	27,900	40

\* Consult factory for metric shaft sizes

\*\* 606 - 6125 Standard NSF H-1 approved grease, 613 - 6175 NSF H-1 approved grease is optional

CYCLO

## CYCLO® 6000 Series

Sumitomo's Gearless

Gearbox: Highly reliable, torque-dense cycloidal speed reducers with 500% momentary shockload capacity. CYCLO® is available in 23 standard sizes.

- **Torque Capacity:** 55 to 603,000 lb-in (6.2 to 68,130 N·m)
- **Power:** 1/8 to 235 HP (.075 to 175 kW)
- **Ratio Range:** 3:1 to 119:1 (single)  
104:1 to 7569:1 (double)  
8041:1 to 658,503:1 (triple)

**Unique Sealing Arrangements**  
Multiple lip, harsh duty, and food grade designs available to prevent leaks

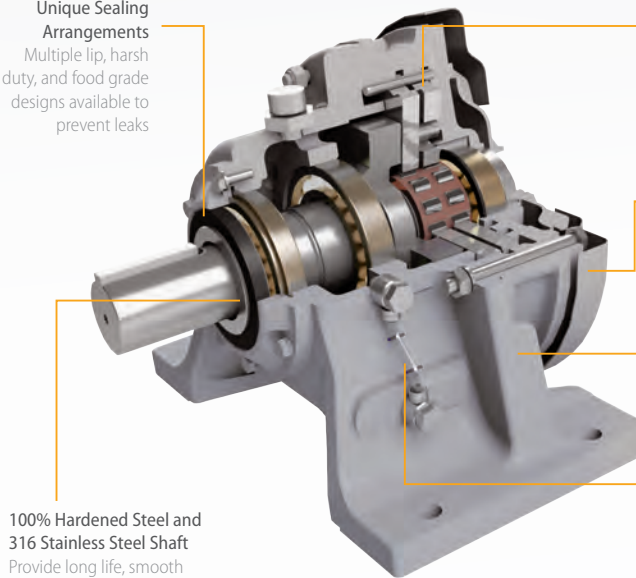

**Hardened Steel Internal Components**  
All rotating components are fully hardened, vacuum-degassed bearing grade steel, for consistent, reliable performance

**Unmatched, Space Saving Design**  
High power density, all reduction contained in compact ring gear housing

**Dependable Housing Designs**  
Rugged, shock-resistant cast iron housing. Optional ductile iron housing also available

**Dynamic Oil Level Indicator**  
Unique oil sight gauge for simple, visible lubrication indication

**100% Hardened Steel and 316 Stainless Steel Shaft**  
Provide long life, smooth operation, and superior strength

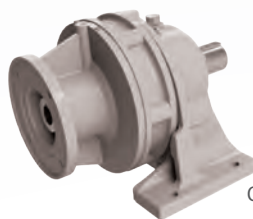

Quill

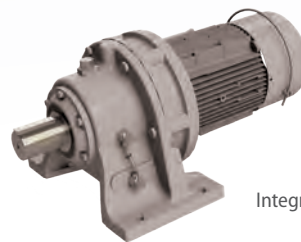

Integral



Overhead  
Conveyor Drive





## RIGHT for food and beverage

From bottling to meat processing and every food industry in between, Sumitomo Machinery Corporation of America provides the Right solutions to keep your facility operating efficiently.

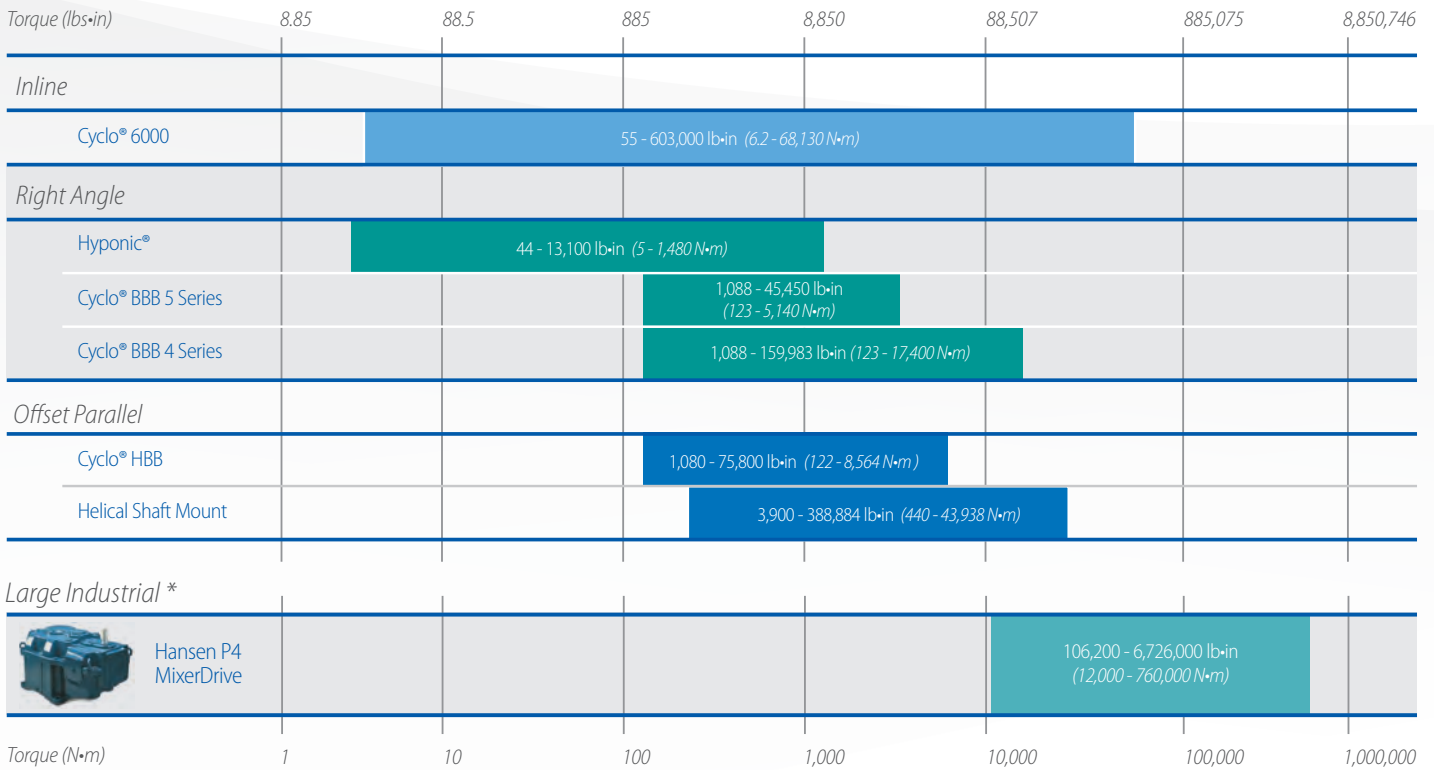

\* Consult factory for availability



### Product Configurator: [www.sumitomodrive.com/Configurator](http://www.sumitomodrive.com/Configurator)

Sumitomo Drive Technologies' online product Configurator streamlines the selection process, enabling you to build **our power transmission products for your specific application.**

Configure your Sumitomo Drive Technologies products today at [www.sumitomodrive.com/Configurator](http://www.sumitomodrive.com/Configurator)

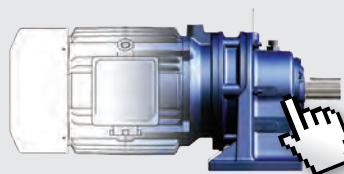

Scan with a QR code reader to log in!



## SHIELD360<sup>0</sup>™ Options

SHIELD360<sup>0</sup>™ comes standard in white and **Chemi SHIELD360<sup>0</sup>™** comes standard in stainless steel gray. Choose the combination of available features that works best for your application.



SHIELD360<sup>0</sup>

MOTOR OPTIONS				
Gasketed Conduit Box	◆	◆	◆	
V Ring Seal-Fan End	◆	◆	◆	
Special Varnish on Windings (Quill Motor Only)			◆	
Sealers @ Joint	◆	◆	◆	
SS Hardware		◆	◆	
DuPont Alesta AM Powder Coat		◆		
FDA White Acrylic Topcoat	◆			
Stainless Steel Gray Acrylic Topcoat			◆	
Stainless Steel Gray 2-Part Epoxy Topcoat				
Brake Cover and Seal	◆	◆	◆	
Powerwash SS-SXT Washdown	Optional For Quill Input	Optional For Quill Input	Optional For Quill Input	◆
REDUCER OPTIONS*				
DuPont Alesta AM Powder Coat		◆		
FDA White Acrylic Topcoat	◆			
Stainless Steel Gray Acrylic Topcoat			◆	
Stainless Steel Gray 2-Part Epoxy Topcoat				◆
FDA Approved Grease	◆	◆		
Triple Lip Seals	◆			
FKM Antimicrobial Cassette Seals		◆	◆	◆
SS Hardware		◆		
SS Nameplate		◆	◆	◆
Corrosion Preventative Plugs (BBB4&5 Only)			◆	◆
Carbon O/P Shaft	◆			
SS O/P Shaft		◆	◆	◆

\* Low Temp and High Temp Duty Packages available. Consult Factory for complete details.



## Applications

Sumitomo Gearboxes span a wide range of industrial uses. This chart quickly displays the most common uses for food and beverage applications.



HYPONIC®



BBB4



BBB5



CYCLO® 6000

Agitators		◆	◆	◆
Batching Equipment	◆			◆
Blender		◆	◆	◆
Conveyors	◆	◆	◆	◆
Carousel Conveyor	◆	◆	◆	◆
Chiller		◆	◆	◆
Crystallizer				◆
Overhead Doors	◆			◆
Drag Conveyors				◆
Drying Drum		◆	◆	◆
Extruder				◆
Fabrication	◆	◆	◆	◆
Feeders	◆	◆	◆	◆
Filler Equipment	◆			◆
Grinder		◆	◆	◆
Loaders/Unloaders	◆			◆
Mixing Drum		◆	◆	◆
Palletizer				◆
Packing Equipment	◆			◆
Proofer	◆			◆
Pumps				
Rendering		◆	◆	◆
Screw Conveyors		◆	◆	◆
Sheeter	◆	◆	◆	
Shrink Wrapping				
Wastewater Treatment		◆	◆	◆





Strength in One

### Sumitomo Drive Technologies

Sumitomo, Hansen and Seisa. Three companies, one global power transmission solutions provider. Sumitomo Drive Technologies has facilities strategically located throughout the world, providing comprehensive products and services in your region.



- ★ MANUFACTURING HUB
- ASSEMBLY & SERVICE
- ▲ REGIONAL SALES OFFICE

Global Headquarters, Tokyo, Japan

Sumitomo Machinery Corporation of America  
[www.sumitomodrive.com](http://www.sumitomodrive.com)  
[www.sumitomodrive.com/right4food](http://www.sumitomodrive.com/right4food)

For worldwide locations, please visit [www.sumitomodrive.com/worldwide](http://www.sumitomodrive.com/worldwide)  
Contact your local representative at [www.sumitomodrive.com/representative](http://www.sumitomodrive.com/representative)  
Tel: 1-800-SM-CYCLO (762-9256)