

Worldwide Locations

U.S.A

Sumitomo Machinery Corporation of America (SMA)
4200 Holland Blvd. Chesapeake,VA 23323,U.S.A.
TEL (1)757-485-3355 FAX (1)757-485-7490

Canada

SM Cyclo of Canada, Ltd. (SMC)
1453 Cornwall Road,Oakville, Canada ON L6J 7T5
TEL (1)905-469-1050 FAX (1)905-469-1055

Mexico

SM Cyclo de Mexico, S.A. de C.V. (SMME)
Av. Desarrollo No.541, Parque Industrial Finsa Monterrey
Guadalupe, Guadalupe, Nuevo Leon, Mexico, CP67114
TEL (52)81-8144-5130 FAX (52)81-8369-3699

Brazil

SM Cyclo Redutores do Brasil, Com.Ltda. (SMBR)
Av. Marquês de São Vicente, 587-Barra Funda,
São Paulo-SP, 01139-001, Brasil
TEL (55)11-5585-3600 FAX (55)11-5585-3600

Chile

SM Cyclo de Chile, Ltda. (SMCH)
San Pablo 3507, Quinta Normal, Santiago, Chile
TEL (56)2-892-7000 FAX (56)2-892-7001

Argentina

SM Cyclo de Argentina S.A. (SMAR)
Ing. Delpini, 2236Area de Promocion el Triangulo,
Partido Malvinas Argentinas Grand Bourg,
Buenos Aires, Argentina B1615KGB
TEL (54)3327-45-4095 FAX (54)3327-45-4099

Guatemala

SM Cyclo de Guatemala Ensambladora, Ltda. (SMGT)
Parque Industrial Unisur, 0 Calle B 19-50 Zona 3,
Bodega D-1 Delta Bárcenas en Villa Nueva, Guatemala
TEL (502)6648-0500 FAX (502)6631-9171

Colombia

SM Cyclo Colombia, S.A.S.
Carrera 11, No.93A-53, Office 203, Bogotá, Colombia
TEL (57)1-3000673

Germany

Sumitomo (SHI) Cyclo Drive Germany GmbH (SCG)
Cyclostraße 92, 85229 Markt Indersdorf, Germany
TEL (49)8136-66-0 FAX (49)8136-5771

Austria

Sumitomo (SHI) Cyclo Drive Germany GmbH (SCG)
SCG Branch Austria Office
Gruentalerstraße 30A, 4020 Linz, Austria
TEL (43)732-330958 FAX (43)732-331978

Belgium

Sumitomo (SHI) Cyclo Drive Germany GmbH (SCG)
SCG Branch Benelux Office
Heikneuterlaan 23, 3010 Kessel-Lo, Leuven, Belgium
TEL (32)16-60-83-11 FAX (32)16-60-16-39

France

SM-Cyclo France SAS (SMFR)
8 Avenue Christian Doppler, 77700 Serris, France
TEL (33)164171717 FAX (33)164171718

Italy

SM-Cyclo Italy Srl (SMIT)
Via dell' Artigianato 23, 20010 Cornaredo (MI), Italy
TEL (39)293-481101 FAX (39)293-481103

Spain

SM-Cyclo Iberia, S.L.U. (SMIB)
C/Landabarri No. 3, 6° B. 48940 Leioa, Vizcaya, Spain
TEL (34)9448-05389 FAX (34)9448-01550

Sweden

SM-Cyclo Scandinavia AB (SMSC)
Industrigatan 21B, 234 35 Lomma, Sweden
TEL (46)40220030

United Kingdom

SM-Cyclo UK Ltd. (SMUK)
Unit 29, Bergen Way, Sutton Fields Industrial Estate,
Kingston upon Hull, HU7 0YQ, East Yorkshire,
United Kingdom
TEL (44)1482-790340 FAX (44)1482-790321

Turkey

SM Cyclo Turkey Güç Aktarım Sis. Tic. Ltd. Sti. (SMTR)
Büyükdere Çayırbaşı Cd. Dede Yusuf Sk. No:11,
34453 Sarıyer Istanbul, Turkey
TEL (90)216-384-4482 FAX (90)216-384-4482

China

Sumitomo (SHI) Cyclo Drive China, Ltd. (SCT)
11F, SMEG Plaza, No.1386 Hongqiao Road,
Changning District, Shanghai, China (P.C.200336)
TEL (86)21-3462-7877 FAX (86)21-3462-7922

Hong Kong

SM-Cyclo of Hong Kong Co.,Ltd. (SMHK)
Rm 1301, CEO Tower, 77 Wing Hong Street,
Cheung Sha Wan, Kowloon, Hong Kong
TEL (852)2460-1881 FAX (852)2460-1882

Korea

Sumitomo (SHI) Cyclo Drive Korea, Ltd. (SCK)
Royal Bldg. 9F Rm.913, 5 Danju-Dong, Chongro-Ku,
Seoul, Korea 110-721
TEL (82)2-730-0151 FAX (82)2-730-0156

Taiwan

Tatung SM-Cyclo Co., Ltd. (TSC)
22 Chungshan N. Road 3rd., Sec. Taipei, Taiwan 104,
R.O.C.
TEL (886)2-2595-7275 FAX (886)2-2595-5594

Singapore

Sumitomo (SHI) Cyclo Drive Asia Pacific Pte. Ltd. (SCA)
15 Kwong Min Road, Singapore 628718
TEL (65)6591-7800 FAX (65)6863-4238

Philippines

Sumitomo (SHI) Cyclo Drive Asia Pacific Pte. Ltd. (SCA)
Philippines Branch Office
B2B Granville Industrial Complex, Carmona, Cavite,
Philippines
TEL (63)2-584-4921 FAX (63)2-584-4922
TEL (63)46-430-3591
TEL (63)46-482-0580
TEL (63)46-482-0581

Vietnam

Sumitomo (SHI) Cyclo Drive Asia Pacific Pte. Ltd. (SCA)
SCA Representative Office in Ho Chi Minh
10th Floor, ACB Tower. 444A-446 Cach Mang
Thang Tam Street, Ward 11, Dist.3, HCMC. Vietnam
TEL (84)8-39-930-021 FAX (84)8-39-930-061

Malaysia

SM-Cyclo of Malaysia Sdn. Bhd. (SMMA)
No.7C, Jalan Anggerik Mokara 31/56, Kota Kemuning,
Seksyen 31, 40460 Shah Alam, Selangor D.E., Malaysia
TEL (60)3-51210455 FAX (60)3-51210578

Indonesia

PT. SM-Cyclo Indonesia
Kawasan Industri Lippo Cikarang Jalan Sungkai Blok F 25
No.09 K Delta Silicon 5 Lippo Cikarang, Bekasi, Indonesia
TEL (62)21-2961-2100 FAX (62)21-2961-2211

Thailand

SM-Cyclo (Thailand) Co., Ltd.
195 Empire Tower, 21st Fl., Unit 2103-4, South Sathorn
Rd.,
Yannawa Sathorn, Bangkok 10120, Thailand
TEL (66)2-670-0998 FAX (66)2-670-0999

Australia

Sumitomo (SHI) Hansen Australia Pty. Ltd. (SHAU)
181 Power Street Glendenning NSW 2761, Australia
TEL (61)2-9208-3000 FAX (61)2-9208-3050

India

Sumi-Cyclo Drive India Pvt. Ltd. (SMIN)
Survey No.130, Hissa No.02, Jeevan Nagar, Off Mumbai-
Bangalore bypass, Tathawade, Pune-411 033, India
TEL (91)20-6674-2900 FAX (91)20-6674-2901

Japan

Sumitomo Heavy Industries, Ltd.
ThinkPark Tower, 1-1 Osaki 2-chome, Shinagawa-ku,
Tokyo 141-6025, Japan
TEL (81)3-6737-2511 FAX (81)3-6866-5160

Specifications, dimensions, and other items are subject to change without prior notice.

 Sumitomo Heavy Industries, Ltd.

Power Transmission & Controls Group

Headquarter ThinkPark Tower, 1-1 Osaki 2-chome, Shinagawa-ku, Tokyo 141-6025, Japan

No.D2401E-1.0

EA01 Printed 2015.02

Sumitomo Drive Technologies



Sensorless Vector Inverter

INVERTER

HF-430 α series

 Sumitomo Heavy Industries, Ltd.

No.D2401E-1

High-performance sensorless vector inverter HF Series is much easier to use.

● Powerful operation

The sensorless control provides high starting torque, and high-performance operation.

- The starting torque is 200% at 0.5 Hz and the torque during operation is more than 150% using the inverter motor.
- The on-line/off-line tuning identifies the motor characteristics for the best performance.



● Noise reduction by the built-in noise filter

- Occurrence noise from the inverter is reduced because it has the EMC noise filter built-in by the standard.
EMC directive is cleared only by HF-430α except 5A5-N type. (Note 1)

● Easy operation

- Parameters setting become easier.
Only the parameter to which the setting was changed can be indicated.
Display restriction of the operating panel is done and indicates max.12 data.
The function which makes only the parameter which is usually used indicates.

● Easy maintenance

- The detachable cooling fan, power capacitors, and control terminal block facilitate maintenance.

Note 1. When the EMC noise filter is made effective, it increases in leakage current.
Leakage current (EMC filter ON: 23~95mA, OFF: 0.1~0.2mA)

Communication function

- RS-485 Modbus-RTU
- CC-Link、 Device Net (Option)

Global standards



Power Range

Voltage class (Input/Rated Output)	Applicable Motor (kW)								
	5.5	7.5	11	15	22	30	37	45	55
3-phase 200V/3-phase 200V									
3-phase 400V/3-phase 400V									

Model No.

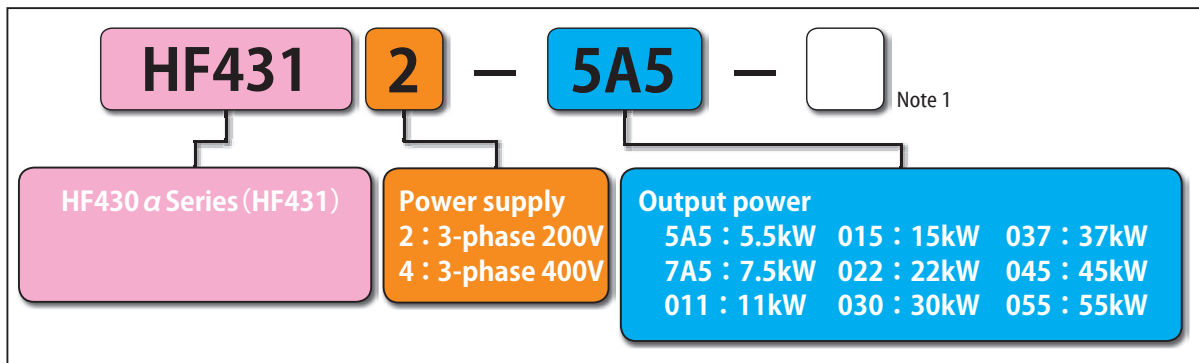

Note 1. N : without EMC filter (5A5)
naught : built in EMC filter (5A5 to 55)

Table of Contents

Explanation of Function	1 to 2	Applicable Wiring for Accessories and Options	26
Standard specifications	3 to 4	Peripheral Equipment	27
Protective Functions	5 to 6	Braking Unit and Braking Resistor	28 to 29
Outline Drawing	7 to 8	Outline Drawing of Braking Unit	30
Operation	9 to 10	Outline Drawing of Braking Unit and Braking Resistor	31
List of Functions	11 to 22	External Options	32 to 38
Terminal Function	23 to 24	Notes to Inverter Users	39 to 40
Standard Connection Diagram	25	Warranty	41

Standard Specifications

Model		HF4312									HF4314								
		-5A5 -5A5-N	-7A5	-011	-015	-022	-030	-037	-045	-055	-5A5 -5A5-N	-7A5	-011	-015	-022	-030	-037	-045	-055
Max. applicable motor 4P (kW)		5.5	7.5	11	15	22	30	37	45	55	5.5	7.5	11	15	22	30	37	45	55
Rated capacity (kVA)	200V/400V	8.3	11	15.9	22.1	32.9	41.9	50.2	63.0	76.2	8.3	11	15.9	22.1	32.9	41.9	50.2	63.0	76.2
	240V/480V	9.9	13.3	19.1	26.6	39.4	50.2	60.2	75.6	91.4	9.9	13.3	19.1	26.6	39.4	50.2	60.2	75.6	91.4
Rated input AC voltage		3-phase (3-wire) 200–240 V (±10%), 50 Hz/60 Hz									3-phase (3-wire) 380–480 V (±10%), 50 Hz/60 Hz								
Rated output voltage (Note 3)		3-phase (3-wire) 200–240 V (±10%), (Corresponding to input voltage)									3-phase (3-wire) 380–480 V (±10%), (Corresponding to input voltage)								
Rated output current (A)		24	32	46	69.4	95	121	145	182	220	12	16	23	32	48	58	75	90	110
Braking	Regenerative braking (Note 5)	Built-in DBTR circuit (Discharging resistor installed separately)					Braking unit				Built-in DBTR circuit (Discharging resistor installed separately)					Braking unit			
	Connectable min. resistance (Ω)	16	10	10	7.5	5	-	-	-	-	70	33	35	24	20	-	-	-	-
Control method		Sinusoidal PWM method																	
Output frequency range (Note 4)		0.1–400Hz																	
Frequency accuracy		Digital command ±0.01% and analog command ±0.2% with respect to max. frequency (25±10°C)																	
Frequency resolution		Digital setting: 0.01 Hz; analog setting: max. frequency/4000 (VRF terminal: 12 bit/0 to +10 V; VRF2 terminal: 12 bit/-10 to +10 V)																	
Voltage/frequency characteristics		V/F control constant torque, variable torque, variable vector control, base frequency 30-400 Hz (Note 7)																	
Speed fluctuation		±0.5% (under sensorless vector control)																	
Overload current rating		150%/60s, 200%/0.5s																	
Acceleration/deceleration time		0.01–3600.0 s (straight and curved line setting)																	
Starting torque		200%/0.5 Hz (under sensorless control); 150%/zero speed range torque																	
DC brake		Operation during starting, during deceleration by stop command, or by external input (Braking force, time, and frequency variable)																	
Input signal	Frequency setting	OPU	Setting by UP/DOWN key of digital operator																
		External signal	DC0–+10V, -10–+10V (Input impedance 10kΩ), 4–20mA (Input impedance 100Ω)																
		External port	Setting by RS485 communication																
	Forward/reverse RUN/STOP	OPU	RUN/STOP (Forward and reverse direction are changed by command.)																
		External signal	Forward rotation RUN/STOP and reverse rotation command are possible when the control terminal block is assigned (selection of NO or NC possible), 3-wire input possible																
		External port	Setting by RS485 communication																
	Multifunctional input	8-terminal selection Terminals are selected from among the following for use: Reverse run command (RR), multistep speed (DFL-DFHH), jogging (JOG), external DC brake (DB), B mode (BMD), No.2 acceleration/deceleration (AD2), free run stop (MBS), external error (ES), USP function (USP), commercial changeover (CS), software lock (SFT), analog input changeover (AUT), C mode (CMD), reset (RST), 3-wire start (STA), 3-wire holding (STP), 3-wire forward/reverse (F/R), PID valid/invalid (PID), PID integral reset (PIDC), control gain changeover (CAS), remote operation speed up (UP), remote operation slow down (DWN), remote operation data clear (UDC), forced operation (OPE), multistep bit 1-7 (SF1-SF7), stall prevention changeover (OLR), torque limit provided/not provided (TL), torque limit changeover 1 (TRQ1), torque limit changeover 2 (TRQ2), P/PI changeover (P/PI), brake confirmation (BOK), orientation (ORT), LAD cancel (LAC), position deviation clear (PCLR), 90-degree phase difference permit (STAT), and no allocation (NO)																	
Thermistor input	1 terminal (positive temperature coefficient/negative temperature coefficient thermistor selection possible)																		

Standard Specifications

Model		HF4312									HF4314								
		-5A5 -5A5-N	-7A5	-011	-015	-022	-030	-037	-045	-055	-5A5 -5A5-N	-7A5	-011	-015	-022	-030	-037	-045	-055
Max. applicable motor 4P (kW)		5.5	7.5	11	15	22	30	37	45	55	5.5	7.5	11	15	22	30	37	45	55
Input signal	Multifunctional output	Selection of five open collector output terminals and one relay (1c contact point) terminal Driving (DRV), frequency reaching (UPF1), frequency detection 1 (UPF2), current detection 1 (OL), excessive PID deviation (OD), abnormal signal (AL), frequency detection 2 (UPF3), overtorque (OYQ), instantaneous stop signal (IP), insufficient voltage (UV), torque limit (TRQ), RUN time over (RNT), ON time over (ONT), electronic thermal alarm (THM), brake release (BRK), brake abnormal (BER), zero speed signal (ZS), excessive speed deviation (DSE), positioning complete (POK), frequency detection 3 (UPF4), frequency detection 4 (UPF5), current detection 2 (OL2), and alarm code 0-3 (AC0-AC3)																	
	Multifunctional monitor	0-10 VDC (max. 2 mA)/4-20 mA DC (load 250Ω or less)/0-10 VDC (PWM, max. 1.2 mA)																	
Display monitor		Output frequency, output current, torque, frequency conversion value, error history, input/output terminal state, input power, etc.																	
Other functions		V/F free setting (7 points), upper/lower frequency limiter, frequency jump, curved-line acceleration/deceleration, manual torque boost level/break point, energy-saving operation, analog meter adjustment, starting frequency, carrier frequency adjustment, electronic thermal, free setting, external start/end (frequency/percentage), analog input selection, error retry, instantaneous stop and start, various signal output, reduced voltage starting, overload limit, initialization value setting, automatic deceleration for power cut off, AVR function, and auto tuning (on-/off-line)																	
Carrier frequency range		0.5-15kHz																	
Protective function		Overcurrent, overvoltage, insufficient voltage, electronic thermal, temperature error, start-up earth current, instantaneous stop, USP error, open-phase error, braking resistor overloading, CT error, external error, communication error, option error, etc.																	
Input signal	Ambient temperature/storage temperature (Note 6)/humidity	-10-50°C/-20-65°C/20-90%RH (Dew condensation not allowed.)																	
	Vibration (Note 1)	5.9m/s ² (0.6G), 10-55Hz																	
	Place of use	Not exceeding 1000 above sea level (Corrosive gas and dust not allowed.)																	
Option	Open-network	DeviceNet, CC-Link																	
	Feedback option	PG vector control																	
Other options		Braking resistor, AC reactor, DC reactor, Digital operator, noise filter, and regenerative braking unit																	
Approx. weight (kg) (Note 8)		6 (3.5)	6	6	14	14	22	30	30	43	6 (3.5)	6	6	14	14	22	30	30	30

- Note: 1.Conforms to the JIS C0911 (1984) test method.
 2.The insulation distance conforms to UL and CE standards.
 3.The output voltage lowers when the supply voltage lowers. (Except cases where the AVR function is selected.)
 4.When the motor operation exceeds 50/60 Hz, contact our company to confirm the allowable max. speed, etc.
 5.Inverters are not equipped with a braking resistor. When large regenerative torque is required, use an optional braking resistor or regenerative braking unit.
 6.The storage temperature is the temperature during transportation.
 7.When the base frequency is other than 60 Hz, the characteristics of the motor and speed reducer must be confirmed.
 8.() is appox. weight for 5A5-N type.

Protective Functions

Name	Description	Display of digital operator	Display of remote operator/ Copy unit ERR1 ***
Over-current protection	Motor is restricted and decelerates rapidly, excessive current is drawn through the inverter and there is a risk of damage. Current protection circuit operates and the inverter output is switched off.	At constant Speed	E01 OC. Drive
		On deceleration Speed	E02 OC. Decel
		On acceleration Speed	E03 OC. Accel
		Other	E04 Over. C
Overload protection (Note 1)	When the Inverter detects an overload in the motor, the internal electronic thermal overload operates and the inverter output is switched off.	E05	Over. L
Braking resistor overload protection	When DBTR exceeds the usage ratio of the regenerative Braking resistor, the over-voltage circuit operates and the inverter output is switched off.	E06	OL. BRD
Over-voltage protection	When regenerative energy from the motor exceeds the maximum level, the over-voltage circuit operates and the inverter output is switched off.	E07	Over. V
EEPROM error (Note 2)	When EEPROM in the inverter is subject to radiated noise or unusual temperature rises, the inverter output is switched off.	E08	EEPROM
Under-voltage	When the incoming voltage of inverter is low, the control circuit can't operate correctly. The under-voltage circuit operates and the inverter output is switched off.	E09	Under. V
CT error	When an abnormality occurs to a CT (current detector) in the inverter, the inverter output is switched off.	E10	CT
CPU error	When a mistaken action causes an error to the inbuilt CPU, the inverter output is switched off.	E11	CPU
External trip	When a signal is given to the EXT multifunctional input terminal, the inverter output is switched off. (on external trip function select)	E12	EXTERNAL
USP error	This is the error displayed when the inverter power is restored while still in the RUN mode. (Valid when the USP function is selected)	E13	USP
Ground fault protection	When power is turned ON, this detects ground faults between the inverter output and the motor.	E14	GND. Flt.
Input over-voltage protection	When the input voltage is higher than the specification value, this detects it for 60 seconds then the over-voltage circuit operates and the inverter output is switched off.	E15	OV. SRC
Temporary power loss protection	When an instantaneous power failure occurs for more than 15ms, the inverter output is switched off. Once the instantaneous power failure wait time has elapsed and the power has not been restored it is regarded as a normal power failure. However, when the operation command is still ON with restart selection the inverter will restart. So please be careful of this.	E16	Inst. P-F
Abnormal temperature	When main circuit temperature raises by stopping of cooling fan, the inverter output is switched off.	E21	OH. FIN
Gate Allay error	Communication error between CPU and gate allay indicate	E23	GA
Open-phase protection	When an open-phase on the input supply occurs the inverter output is switched off.	E24	PH. Fail
Overload protection 2	When the Inverter detects an overload in the motor (under 0.2Hz), the inverter output is switched off.	E25	Over. L2
IGBT error	When an instantaneous over-current is detected on the output the inverter output is switched off to protect the main devices.	E30	IGBT
Thermistor error	When the Inverter detects a high resistance on the thermistor input from the motor the inverter output is switched off.	E35	TH
Abnormal brake	When inverter cannot detect switching of the brake (ON/FF) after releasing the brake, and for waiting for signal condition (b124) (When the braking control selection (b120) is enable.)	E36	BRAKE
Emergency stop (Note 3)	If the EMR signal (on three terminals) is turned on when the slide switch (SW1) on the logic card is set to ON, the inverter hardware will shut off the inverter output and display the error code shown on the right. Malfunction due to incoming noise, in case EMR terminal is not ON.	E37	EMR
Low-speed overload protection	If overload occurs during the motor operation at a very low speed at 0.2 Hz or less, the electronic thermal protection circuit in the inverter will detect the overload and shut off the inverter output. (2nd electronic thermal control)(Note that a high frequency may be recorded as the error history data.)	E38	OL-LowSP
Modbus communication error	If timeout occurs because of line disconnection during the communication in Modbus-RTU mode, the inverter will display the error code shown on the right. (The inverter will trip according to the setting of "C076".)	E41	NET.ERR
Option 1 error 0-9	These indicate the error of option 1. You can realize the details each instruction manual.	E60~E69	OP1-0-9
Option 2 error 0-9	These indicate the error of option 2. You can realize the details by each instruction manual.	E70~E79	OP2-0-9
During under-voltage waiting	When the incoming voltage of the inverter has dropped, the inverter output is switched off and the inverter waits.	----	UV. WAIT

Note: 1.After a trip occurs and 10 seconds pass, restart with reset operation.
 2.When EEPROM error E08 occurs, confirm the setting date again.
 3.Reset the inverter by turning on the RET terminal.

Protective Functions

State display

Code	Contents
0	Resetting
1	Stopping
2	Decelerating
3	At constant speed
4	Accelerating

Code	Contents
5	f0 stopping
6	Starting
7	During DB
8	During overload restriction
9	Forcible or servo-on operation

Trip monitor display

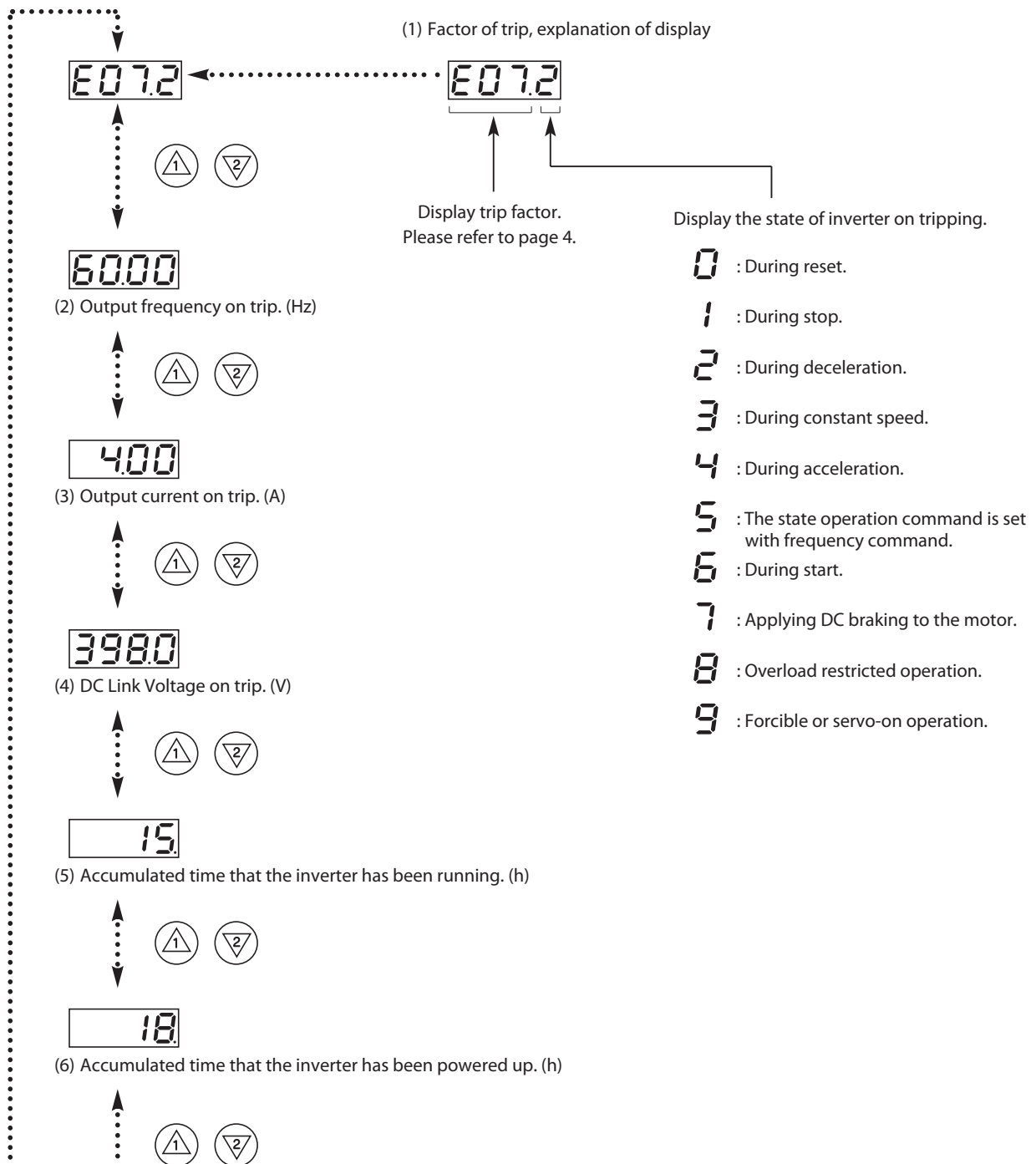

Outline Drawing

HF4312-5A5-N

HF4314-5A5-N

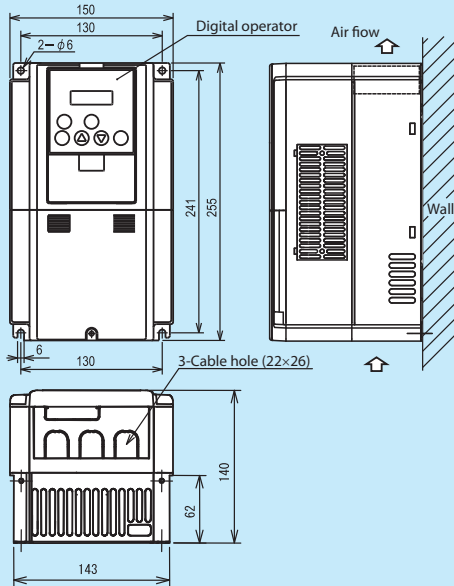

HF4312-5A5, 7A5, 011

HF4314-5A5, 7A5, 011

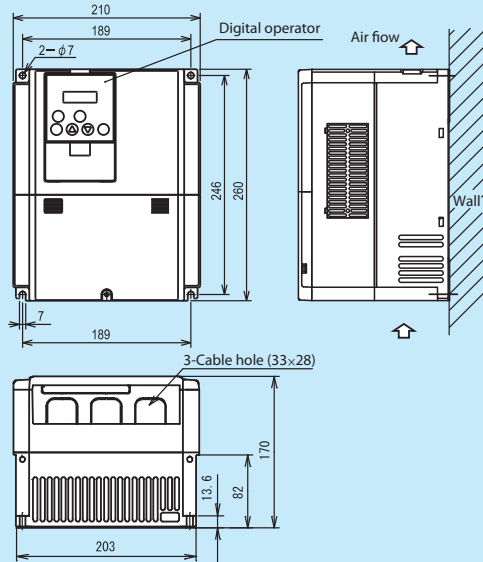

HF4312-015, 022

HF4314-015, 022

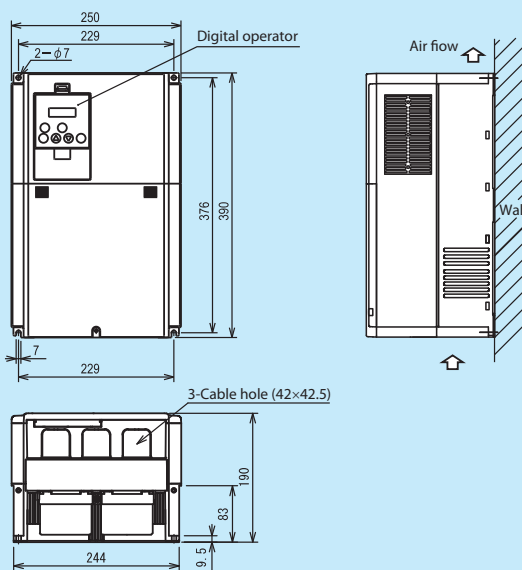

Outline Drawing

HF4312-030
HF4314-030

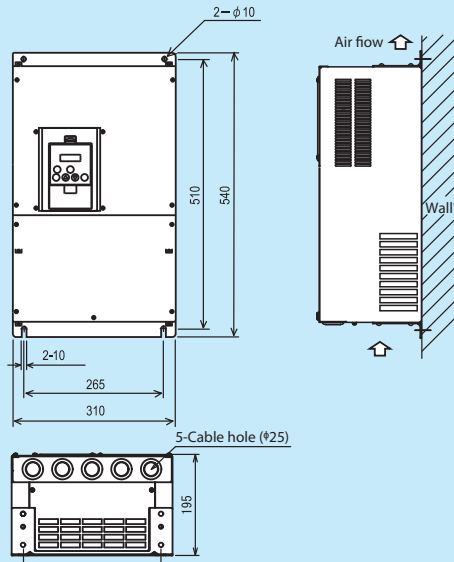

HF4312-037, 045
HF4314-037, 045, 055

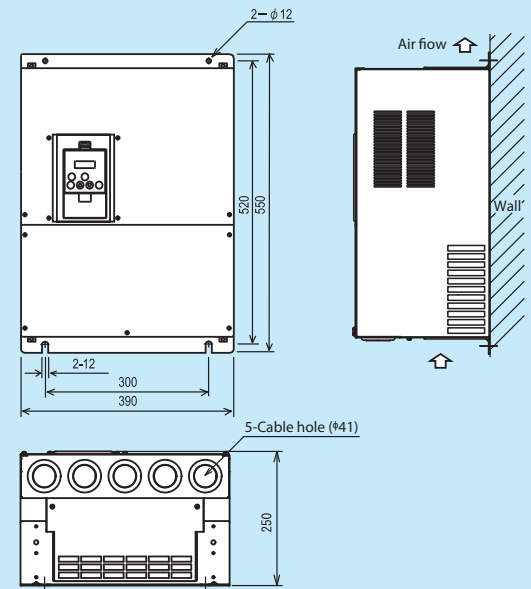

HF4312-055

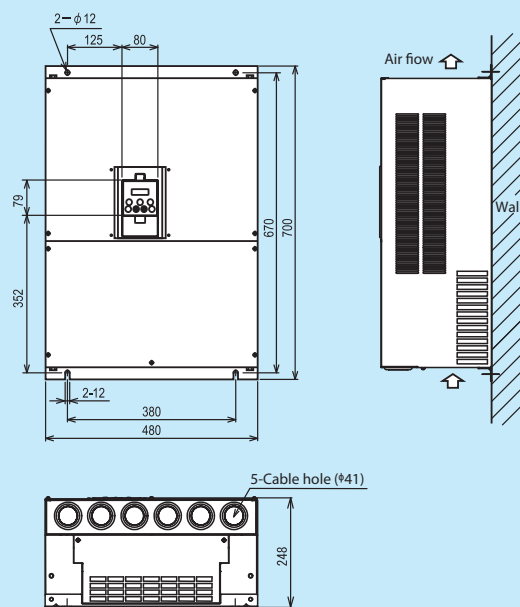

Operation

Digital operator

The HF-430 α Series is operated by the digital operator provided as standard equipment.

1. Name and details of each section of digital operator

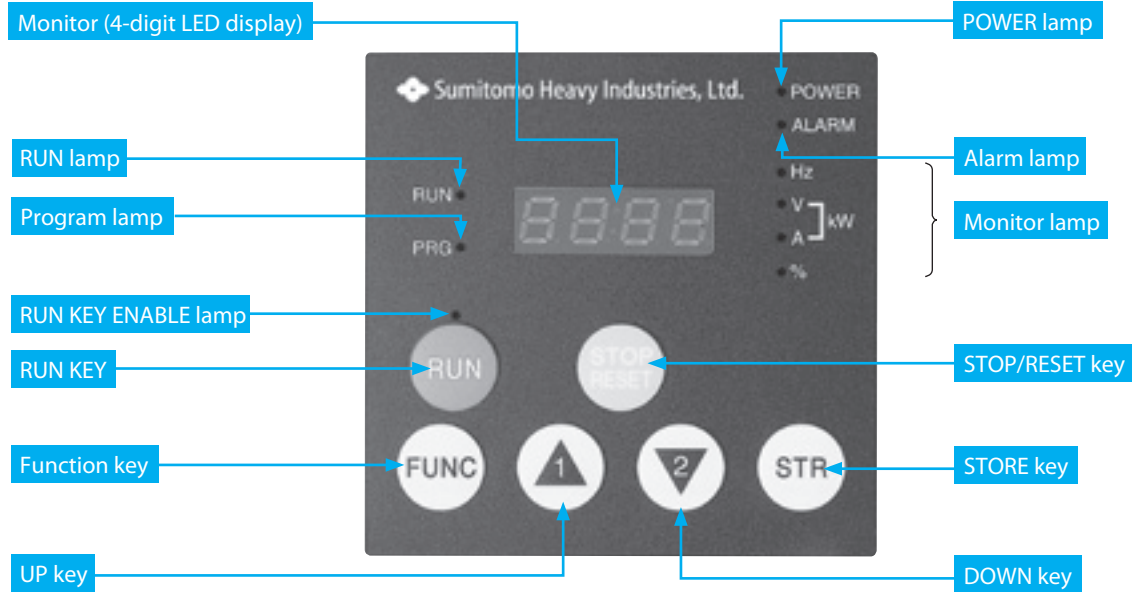

Name	Contents
Monitor	Displays frequency, output current, and set value
RUN lamp	ON during inverter operation
Program lamp	ON when set values of each functions are displayed on the monitor Blinking during warning (set value incomplete)
POWER lamp	Power lamp for control circuit
Alarm lamp	ON when the inverter trips
Monitor lamp	Indicates display on monitor Hz: Frequency V: Voltage A: Current kW: Electric power %: Percentage
RUN KEY ENABLE lamp	ON when the operation command selection (A002) is set in the operator (02) position.
Run key	Used to operate the motor. Valid only when the operation command selection (A002) is in the operator (02) position. (Check that the RUN KEY ENABLE lamp is ON.)
STOP/RESET key	Used for motor stop or error reset
Function key	Used to enter the monitor mode, basic setting mode, extension function mode, or function mode
STORE key	Used to store set values (Be sure to press this key to save set values.)
UP/DOWN key	Used to change the extension function mode, function mode, or set values

Remote operator

Dimensional drawing

- OS-40 (Built in unit)
- OS-43 (Option)
- ICS-1,3 (Cable for OS-40 and 43)

The drawings show the following dimensions and details:

- OS-40 (Built in unit):** Overall width 80, height 79. Mounting cutout drawing shows a 26.5 wide opening with 18 and 2 dimensions, and a 59 high opening with 2-dia.4 holes.
- OS-43 (Option):** Overall width 80, height 123. Mounting cutout drawing shows a 26.5 wide opening with 18 and 2 dimensions, and a 103 high opening with 2-dia.4 holes. Includes a note: "2-M3 depth 3.6 (back) 4.5 (M3 Screw depth 3.5 below)".
- ICS-1,3 (Cable for OS-40 and 43):** Cable length L (m).

Model	Cable length L (m)
ICS-1	1
ICS-3	3

■ **Operation using digital operator**

1. Setting method (Setting max. frequency)

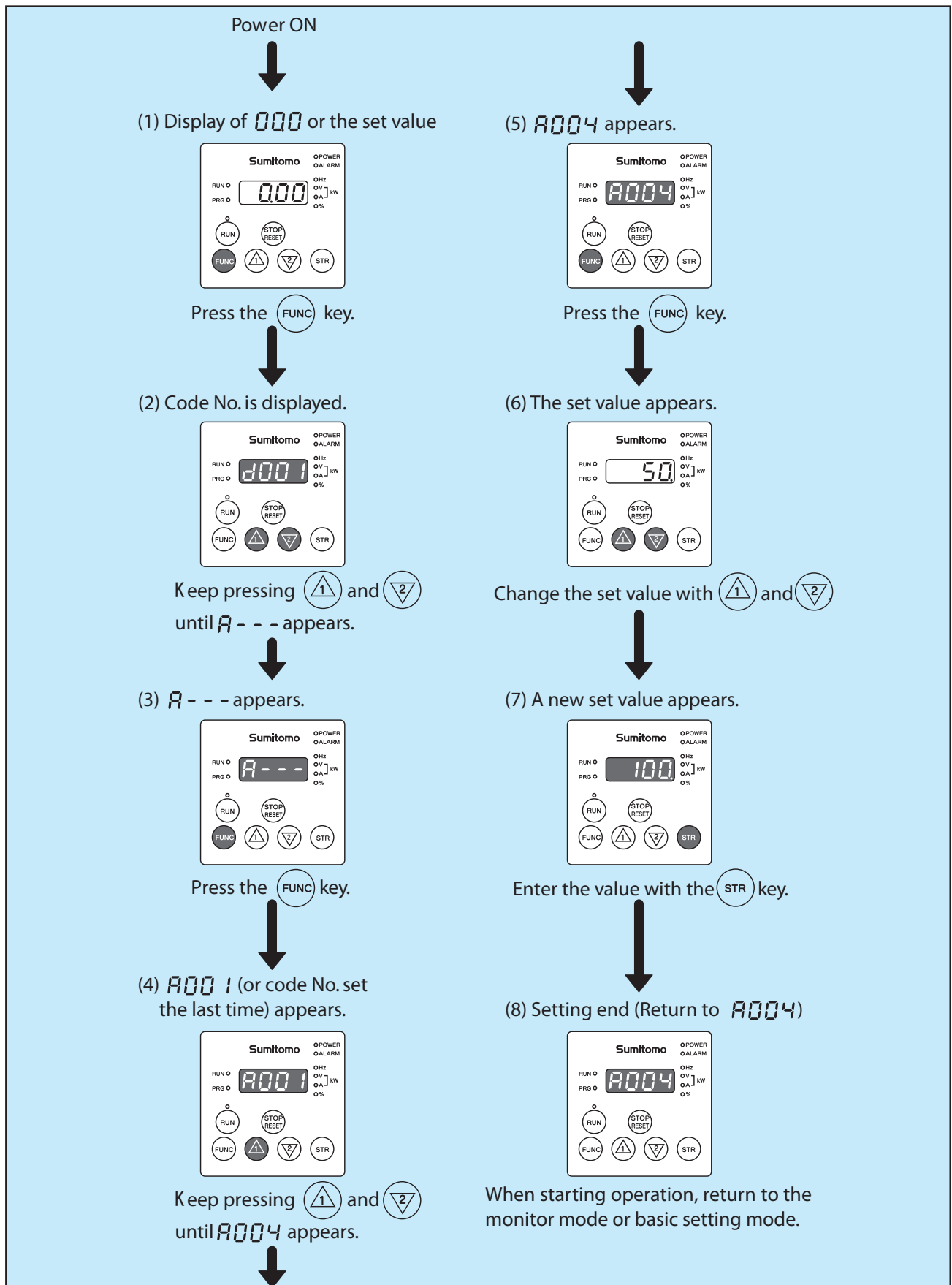

List of Functions

● Monitor mode/basic setting mode “Setting possible in the change mode during operation” is valid when b031 is set to 10.

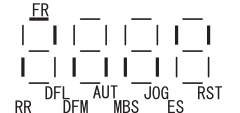
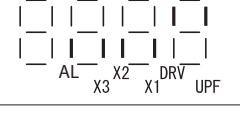
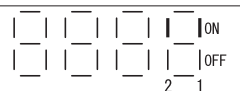
Code	Name of function	Monitor/setting range	Initial setting	Setting possible during operation	Setting possible in the change mode during operation
d001	Output frequency monitoring	0.00 to 99.99/100.0 to 400.0(Hz)	—	○	—
d002	Output current monitoring	0.0 to 999.9/1000 to 9999(A)	—	—	—
d003	Rotation direction monitoring	F (forward rotation), o (stopped), r (reverse rotation)	—	—	—
d004	Process variable (PV), PID feedback monitoring	0.00 to 99.99/100.0 to 999.9/1000. to 9999./1000 to 9999(10000~99990)/ ┌100 to ┌999(100000 to 999000)	—	—	—
d005	Multifunctional input status	 (Example) FR, DFL, ES, and RST: ON RR, DFM, AD2, MBS, and JOG: OFF	—	—	—
d006	Multifunctional output status	 (Example) DRV and UPF: ON AL, X3, X2, and X1: OFF	—	—	—
d007	Scaled output frequency monitoring	0.00 to 99.99/100.0~999.9/1000. to 9999./1000 to 3996(10000 to 39960)	—	○	—
d008	Actual-frequency monitoring	-400. to -100./-99.9 to 0.00 to 99.99/100.0 to 400.0(Hz)	—	—	—
d009	Torque command monitoring	0. to +200.(%)	—	—	—
d010	Torque bias monitoring	-200. to +200.(%)	—	—	—
d012	Torque monitoring	-300. to +300.(%)	—	—	—
d013	Output voltage monitoring	0.0 to 600.0(V)	—	—	—
d014	Power monitoring	0.0 to 999.9(kW)	—	—	—
d015	Cumulative power monitoring	0.0 to 999.9/1000. to 9999./1000 to 9999(10000 to 99990)/ ┌100 to ┌999(100000 to 999000)	—	—	—
d016	Cumulative operation RUN time monitoring	0. to 9999./1000 to 9999(10000 to 99990)/	—	—	—
d017	Cumulative power-on time monitoring	┌100 to ┌999(100000 to 999000) (hr)	—	—	—
d018	Heat sink temperature monitoring	-20.0 to 200.0(°C)	—	—	—
d019	Motor temperature monitoring		—	—	—
d022	Life-check monitoring	 1: Capacitor on main circuit card 2: Cooling-fan speed drop	—	—	—
d023	Program counter	0 to 1024	—	—	—
d024	Program No. monitor	0000 to 9999	—	—	—
d025	User monitor 0	-2147483647 to 2147483647 (upper 4 digits including “-”)	—	—	—
d026	User monitor 1		—	—	—
d027	User monitor 2		—	—	—
d028	Pulse counter	0 to 2147483647 (upper 4 digits)	—	—	—
d029	Position setting monitor	-1073741823 to 1073741823 (upper 4 digits including “-”)	—	—	—
d030	Position feedback monitor		—	—	—
d080	Trip Counter	0. to 9999., 1000 to 6553 (10000 to 65530) (times)	—	—	—
d081 to d086	Trip monitoring 1 to 6	Factor, frequency (Hz), current (A), voltage across P-N (V), running time (hours), power-on time (hours)	—	—	—
d090	Programming error monitoring	Warning code	—	—	—
d102	DC voltage monitoring	0.0 to 999.9(V)	—	—	—
d103	DBR load factor monitoring	0.0 to 100.0(%)	—	—	—
d104	Electronic thermal overload monitoring		—	—	—

List of Functions

● Monitor mode/basic setting mode

“Setting possible in the change mode during operation” is valid when b031 is set to 10.

Code	Name of function	Monitor/setting range	Initial setting	Setting possible during operation	Setting possible in the change mode during operation	
Setting	F001	Output frequency setting	0.0, "start frequency" to "maximum frequency" (or maximum frequency, B mode/C mode motors) (Hz) 0.0 to 100.0 (when PID function is enabled)	0.00Hz	○	○
	F002	Acceleration (1) time setting	0.01 to 99.99/100.0 to 999.9/1000. to 3600.s	30.00s	○	○
	F202	Acceleration (1) time setting, B mode motor		30.00s	○	○
	F302	Acceleration (1) time setting, C mode motor		30.00s	○	○
	F003	Deceleration (1) time setting		30.00s	○	○
	F203	Deceleration time setting, B mode motor		30.00s	○	○
	F303	Deceleration time setting, C mode motor		30.00s	○	○
	F004	Keypad Run key routing		00 (forward rotation), 01 (reverse rotation)	00	×

● Extension function A

Code	Name of function	Monitor/setting range	Initial setting	Setting possible during operation	Setting possible in the change mode during operation	
Basic setting	A001	Frequency source setting	00 (keypad potentiometer) (*1), 01 (control circuit terminal block), 02 (digital operator), 03 (RS485), 04 (option 1), 05 (option 2), 06 (pulse-train input), 07 (easy sequence), 10 (operation function result)	02	×	×
	A002	Run command source setting	01 (control circuit terminal block), 02 (digital operator), 03 (RS485), 04 (option 1), 05 (option 2)	02	×	×
	A003	Base frequency setting	30. to "maximum frequency" (Hz)	60	×	×
	A203	Base frequency setting, B mode motor	30. to "maximum frequency, B mode motor" (Hz)	60	×	×
	A303	Base frequency setting, C mode motor	30. to "maximum frequency, C mode motor" (Hz)	60	×	×
	A004	Maximum frequency setting	30. to 400.(Hz)	60	×	×
	A204	Maximum frequency setting, B mode motor		60	×	×
	A304	Maximum frequency setting, C mode motor		60	×	×
Analog input and others	A005	[AUT] selection	00 (switching between VRF and IRF terminals), 01 (switching between VRF and VRF2 terminals), 02 (switching between VRF terminal and keypad potentiometer) (*1), 03 (switching between IRF terminal and keypad potentiometer) (*1), 04 (switching between VRF2 and keypad potentiometer) (*1)	00	×	×
	A006	[VRF2] selection	00 (single), 01 (auxiliary frequency input via VRF and IRF terminals) (nonreversible), 02 (auxiliary frequency input via VRF and IRF terminals) (reversible), 03 (disabling VRF2 terminal)	03	×	×
	A011	[VRF]-[COM] input active range start frequency	0.00 to 99.99, 100.0 to 400.0 (Hz)	0.00	×	○
	A012	[VRF]-[COM] input active range end frequency		0.00	×	○
	A013	[VRF]-[COM] input active range start voltage	0. to "[VRF]-[COM] input active range end voltage" (%)	0	×	○
	A014	[VRF]-[COM] input active range end voltage	"[VRF]-[COM] input active range start voltage" to 100. (%)	100	×	○
	A015	[VRF]-[COM] input active range start frequency selection	00 (external start frequency), 01 (0 Hz)	01	×	○
	A016	External frequency filter time const.	1. to 30. or 31. (500 ms filter ±0.1 Hz with hysteresis)	31	×	○
A017	Easy sequence function selection	00 (disabling), 01 (enabling)	00	×	○	
Multispeed operation and jogging	A019	Multispeed operation selection	00 (binary: 16 speeds selectable with 4 terminals), 01 (bit: 8 speeds selectable with 7 terminals)	00	×	×
	A020	Multispeed frequency setting	0.0 or "start frequency" to "maximum frequency" (Hz)	10.00	○	○
	A220	Multispeed frequency setting, B mode motor	0.0 or "start frequency" to "maximum frequency, B mode motor" (Hz)	10.00	○	○
	A320	Multispeed frequency setting, C mode motor	0.0 or "start frequency" to "maximum frequency, C mode motor" (Hz)	10.00	○	○
	A021 ∧ A035	Multispeed setting (1st to 15th speed)	0.0 or "start frequency" to "maximum frequency" (Hz)	A21=20.00 A22=30.00 A23=40.00 Others=0.00	○	○
	A038	Jog frequency setting	"Start frequency" to 9.99 (Hz)	5.0	○	○
A039	Jog stop mode	00 (free-running after jogging stops [disabled during operation]), 01 (deceleration and stop after jogging stops [disabled during operation]), 02 (DC braking after jogging stops [disabled during operation]), 03 (free-running after jogging stops [enabled during operation]), 04 (deceleration and stop after jogging stops [enabled during operation]), 05 (DC braking after jogging stops [enabled during operation])	01	×	○	

List of Functions

● Extension function A

Code	Name of function	Monitor/setting range	Initial setting	Setting possible during operation	Setting possible in the change mode during operation	
V/F characteristic	A041	Torque boost method selection	00 (manual torque boost), 01 (automatic torque boost)	00	×	×
	A241	Torque boost method selection, B mode motor		00	×	×
	A042	Manual torque boost value	0.0 to 20.0 (%)	1.0	○	○
	A242	Manual torque boost value, B mode motor		1.0	○	○
	A342	Manual torque boost value, C mode motor		1.0	○	○
	A043	Manual torque boost frequency adjustment	0.0 to 50.0 (%)	0.8	○	○
	A243	Manual torque boost frequency adjustment, B mode motor		0.8	○	○
	A343	Manual torque boost frequency adjustment, C mode motor		0.8	○	○
	A044	V/F characteristic curve selection	00 (VC), 01 (VP), 02 (free V/F), 03 (sensorless vector control), 04 (0Hz-range sensorless vector), 05 (PG vector control)	00	×	×
	A244	V/F characteristic curve selection, B mode motor	00 (VC), 01 (VP), 02 (free V/F), 03 (sensorless vector control), 04 (0Hz-range sensorless vector)	00	×	×
	A344	V/F characteristic curve selection, C mode motor	00(VC), 01(VP)	00	×	×
	A045	V/F gain setting	20. to 100. (%)	100	○	○
	A046	Voltage compensation gain setting for automatic torque boost	0. to 255.	100.	○	○
	A246	Voltage compensation gain setting for automatic torque boost, B mode motor		100.	○	○
	A047	Slippage compensation gain setting for automatic torque boost		100.	○	○
	A247	Slippage compensation gain setting for automatic torque boost, B mode motor		100.	○	○
DC braking	A051	DC braking enable	00 (disabling), 01 (enabling), 02 (set frequency only)	00	×	○
	A052	DC braking frequency setting	0.00 to 99.99, 100.0 to 400.0 (Hz)	0.50	×	○
	A053	DC braking wait time	0.0 to 5.0 (s)	0.0	×	○
	A054	DC braking force during deceleration	0. to 100. (%) <0. to 80. (%)>	0.	×	○
	A055	DC braking time for deceleration	0.0 to 60.0 (s)	0.0	×	○
	A056	DC braking/edge or level detection for [DB] input	00 (edge operation), 01 (level operation)	01	×	○
	A057	DC braking force for starting	0. to 100.(%) <0. to 80. (%)>	0.	×	○
	A058	DC braking time for starting	0.0 to 60.0(s)	0.0	×	○
	A059	DC braking carrier frequency setting	0.5 to 15.0(kHz) <0.5 to 10.0 (kHz) >	5.0 <3.0>	×	×
Frequency upper/lower limit and jump frequency	A061	Frequency upper limit setting	0.00 or "minimum frequency limit" to "maximum frequency" (Hz)	0.00	×	○
	A261	Frequency upper limit setting, B mode motor	0.00 or "B mode minimum frequency limit" to "maximum frequency, B mode motor" (Hz)	0.00	×	○
	A062	Frequency lower limit setting	0.00 or "start frequency" to "maximum frequency limit" (Hz)	0.00	×	○
	A262	Frequency lower limit setting, B mode motor	0.00 or "start frequency" to "maximum frequency, B mode motor limit" (Hz)	0.00	×	○
	A063	Jump (center) frequency setting 1	0.00 to 99.99, 100.0 to 400.0 (Hz)	0.00	×	○
	A064	Jump (hysteresis) frequency width setting 1	0.00 to 10.00 (Hz)	0.50	×	○
	A065	Jump (center) frequency setting 2	0.00 to 99.99, 100.0 to 400.0 (Hz)	0.00	×	○
	A066	Jump (hysteresis) frequency width setting 2	0.00 to 10.00 (Hz)	0.50	×	○
	A067	Jump (center) frequency setting 3	0.00 to 99.99, 100.0 to 400.0 (Hz)	0.00	×	○
	A068	Jump (hysteresis) frequency width setting 3	0.00 to 10.00 (Hz)	0.50	×	○
	A069	Acceleration stop frequency setting	0.00 to 99.99, 100.0 to 400.0 (Hz)	0.00	×	○
	A070	Acceleration stop time frequency setting	0.0 to 60.0 (s)	0.0	×	○

Note: V/f (for constant torque operation) is preset before shipment. Change the setting to "03" for high starting torque or high-performance operation.

List of Functions

● Extension function A

Code	Name of function	Monitor/setting range	Initial setting	Setting possible during operation	Setting possible in the change mode during operation		
PID control	A071	PID Function Enable	00 (disabling), 01 (enabling), 02 (enabling inverted-data output)	00	×	○	
	A072	PID proportional gain	0.2 to 5.0	1.0	○	○	
	A073	PID integral time constant	0.0 to 999.9, 1000. to 3600. (s)	1.0	○	○	
	A074	PID derivative gain	0.00 to 99.99, 100.0 (s)	0.00	○	○	
	A075	PV scale conversion	0.01 to 99.99	1.00	×	○	
	A076	PV source setting	00 (input via IRF), 01 (input via VRF), 02 (external communication), 03 (pulse-train frequency input), 10 (operation result output)	00	×	○	
	A077	Output of inverted PID deviation	00(OFF), 01 (ON)	00	×	○	
	A078	PID variation range	0.0 to 100.0 (%)	0.00	×	○	
	A079	PID feed forward selection	00 (disabled), 01 (VRF input), 02 (IRF input), 03 (VRF2 input)	00	×	○	
AVR	A081	AVR function select	00 (always on), 01 (always off), 02 (off during deceleration)	00	×	×	
	A082	AVR voltage select	200 V class: 200, 215, 220, 230, 240 (V) 400 V class: 380, 400, 415, 440, 460, 480 (V)	200/400	×	×	
Operation mode and acceleration/deceleration function	A085	Operation mode selection	00 (normal operation), 01 (energy-saving operation), 02 (fuzzy operation)	00	×	×	
	A086	Energy saving mode tuning	0.1 to 100.0	50.0	○	○	
	A092	Acceleration (2) time setting	0.01 to 99.99, 100.0 to 999.9, 1000. to 3600. (s)	30.00	○	○	
	A292	Acceleration (2) time setting, B mode motor		30.00	○	○	
	A392	Acceleration (2) time setting, C mode motor		30.00	○	○	
	A093	Deceleration (2) time setting		30.00	○	○	
	A293	Deceleration (2) time setting, B mode motor		30.00	○	○	
	A393	Deceleration (2) time setting, C mode motor		30.00	○	○	
	A094	Select method to switch to Acc2/Dec2 profile		00 (switching by AD2 terminal), 01 (switching by setting), 02 (switching only when rotation is reversed)	00	×	×
	A294	Select method to switch to Acc2/Dec2, B mode motor			00	×	×
	A095	Acc1 to Acc2 frequency transition point	0.00 to 99.99, 100.0 to 400.0 (Hz)	0.00	×	×	
	A295	Acc1 to Acc2 frequency transition point, B mode motor		0.00	×	×	
	A096	Dec1 to Dec2 frequency transition point		0.00	×	×	
	A296	Dec1 to Dec2 frequency transition point, B mode motor		0.00	×	×	
	A097	Acceleration curve selection		00	×	×	
	A098	Deceleration curve setting		00	×	×	
External frequency adjustment	A101	[IRF]-[COM] input active range start frequency	0.00	×	×		
	A102	[IRF]-[COM] input active range end frequency	0.00	×	○		
	A103	[IRF]-[COM] input active range start current	0. to "[IRF]-[COM] input active range end current" (%)	20.	×	○	
	A104	[IRF]-[COM] input active range end current	"[IRF]-[COM] input active range start current" to 100. (%)	100.	×	○	
	A105	[IRF]-[COM] input start frequency enable	00 (external start frequency), 01 (0 Hz)	01	×	○	
	A111	[VRF2]-[COM] input active range start frequency	-400. to -100., -99.9 to 0.00 to 99.99, 100.0 to 400.0 (Hz)	0.00	×	○	
	A112	[VRF2]-[COM] input active range end frequency		0.00	×	○	
	A113	[VRF2]-[COM] input active range start voltage	-100. to 02 end-frequency rate (%)	-100.	×	○	
A114	[VRF2]-[COM] input active range end voltage	"02 start-frequency rate" to 100. (%)	100.	×	○		
Acceleration and deceleration	A131	Acceleration curve constants setting	01 (smallest swelling) to 10 (largest swelling)	02	×	×	
	A132	Deceleration curve constants setting		02	×	×	

List of Functions

● Extension function b

Code	Name of function	Monitor/setting range	Initial setting	Setting possible during operation	Setting possible in the change mode during operation	
Restart after instantaneous power failure or tripping	b001	Selection of restart mode	00 (tripping), 01 (starting with 0 Hz), 02 (starting with matching frequency), 03 (tripping after deceleration and stopping with matching frequency), 04 (restarting with active matching frequency)	00	×	○
	b002	Allowable under-voltage power failure time	0.3 to 25.0 (s)	1.0	×	○
	b003	Retry wait time before motor restart	0.3 to 100.0 (s)	1.0	×	○
	b004	Instantaneous power failure/ under-voltage trip alarm enable	00 (disabling), 01 (enabling), 02 (disabling during stopping and decelerating to stop)	00	×	○
	b005	Number of restarts on power failure/under-voltage trip events	00 (16 times), 01 (unlimited)	00	×	○
	b006	Phase loss detection enable	00 (disabling), 01 (enabling)	00	×	○
	b007	Restart frequency threshold	0.00 to 99.99, 100.0 to 400.0 (Hz)	0.00	×	○
	b008	Selection of retry after tripping	00 (tripping), 01 (starting with 0 Hz), 02 (starting with matching frequency), 03 (tripping after deceleration and stopping with matching frequency), 04 (restarting with active matching frequency)	00	×	○
	b009	Selection of retry after undervoltage	00 (16 times), 01 (unlimited)	00	×	○
	b010	Selection of retry count after overvoltage or overcurrent	1 to 3 (times)	3	×	○
	b011	Retry wait time after tripping	0.3 to 100.0 (s)	1.0	×	○
Electronic thermal function	b012	Electronic thermal setting	0.20 x "rated current" to 1.00 x "rated current" (A)	Rated current of inverter	×	○
	b212	Electronic thermal setting, B mode motor		Rated current of inverter	×	○
	b312	Electronic thermal setting, C mode motor		Rated current of inverter	×	○
	b013	Electronic thermal characteristic	00 (reduced-torque characteristic), 01 (constant-torque characteristic), 02 (free setting)	00	×	○
	b213	Electronic thermal characteristic, B mode motor		00	×	○
	b313	Electronic thermal characteristic, C mode motor		00	×	○
	b015	Free setting, electronic thermal frequency (1)	0. to 400. (Hz)	0.	×	○
	b016	Free setting, electronic thermal current (1)	0.0 to rated current (A)	0.0	×	○
	b017	Free setting, electronic thermal frequency (2)	0. to 400. (Hz)	0.	×	○
	b018	Free setting, electronic thermal current (2)	0.0 to rated current (A)	0.0	×	○
	b019	Free setting, electronic thermal frequency (3)	0. to 400. (Hz)	0.	×	○
b020	Free setting, electronic thermal current (3)	0.0 to rated current (A)	0.0	×	○	
Stall prevention and overcurrent restraint	b021	Stall prevention operation mode	00 (disabling), 01 (enabling during acceleration and deceleration), 02 (enabling during constant speed), 03 (enabling during acceleration and deceleration (increasing the speed during regeneration))	01	×	○
	b022	Stall prevention setting	0.20 x "rated current" to 2.00 x "rated current" (A)	Rated current of inverter x 1.50	×	○
	b023	Deceleration rate at stall prevention	0.10 to 30.00 (s)	1.00	×	○
	b024	Stall prevention operation mode (2)	00 (disabling), 01 (enabling during acceleration and deceleration), 02 (enabling during constant speed), 03 (enabling during acceleration and deceleration (increasing the speed during regeneration))	01	×	○
	b025	Stall prevention setting (2)	0.20 x "rated current" to 2.00 x "rated current" (A)	Rated current of inverter x 1.50	×	○
	b026	Deceleration rate at stall prevention (2)	0.10 to 30.00 (s)	1.00	×	○
	b027	Overcurrent suppression enable	00 (disabling), 01 (enabling)	00	×	○
	b028	Active frequency matching, scan start frequency	0.20 x "rated current" to 2.00 x "rated current" (A)	Rated current of inverter	×	○
	b029	Active frequency matching, scan-time constant	0.10 to 30.00 (s)	0.50	×	○
	b030	Active frequency matching, restart frequency select	00 (frequency at the last shutoff), 01 (maximum frequency), 02 (set frequency)	00	×	○

List of Functions

● Extension function b

Code		Name of function	Monitor/setting range	Initial setting	Setting possible during operation	Setting possible in the change mode during operation
Software lock	b031	Software lock mode selection	00 (disabling change of data other than "b031" when SFT is on), 01 (disabling change of data other than "b031" and frequency settings when SFT is on), 02 (disabling change of data other than "b031"), 03 (disabling change of data other than "b031" and frequency settings), 10 (enabling data changes during operation)	01	×	○
Others	b034	Run/power-on warning time	0. to 9999. (0 to 99990), 1000 to 6553 (100000 to 655300) (hr)	0	×	○
	b035	Rotational direction restriction	00 (enabling both forward and reverse rotations), 01 (enabling only forward rotation), 02 (enabling only reverse rotation)	00	×	×
	b036	Reduced voltage start selection	0 (minimum reduced voltage start time) to 255 (maximum reduced voltage start time)	6	×	○
	b037	Function code display restriction	00 (full display), 01 (function-specific display), 02 (user setting), 03 (data comparison display), 04 (basic display)	04	×	○
	b038	Initial-screen selection	00 (screen displayed when the STR key was pressed last), 01 (d001), 02 (d002), 03 (d003), 04 (d007), 05 (F001)	01	×	○
	b039	Automatic user-parameter setting function enable	00 (disabling), 01 (enabling)	00	×	○
Torque limitation	b040	Torque limit selection	00 (quadrant-specific setting), 01 (switching by terminal), 02 (analog input), 03 (option 1), 04 (option 2)	00	×	○
	b041	Torque limit (1)	0. to 200. (%), no (disabling torque limitation)	150.	×	○
	b042	Torque limit (2)		150.	×	○
	b043	Torque limit (3)		150.	×	○
	b044	Torque limit (4)		150.	×	○
	b045	Torque limit LADSTOP enable	00 (disabling), 01 (enabling)	00	×	○
	b046	Reverse Run protection enable		00	×	○
Non-stop operation at momentary power failure	b050	Controller deceleration and stop on power loss	00 (disabling), 01 (nonstop deceleration to stop), 02 (DC voltage constant control, with resume), 03 (without resume)	00	×	×
	b051	DC bus voltage trigger level during power loss	0.0 to 999.9, 1000. (V)	220.0/440.0	×	×
	b052	Over-voltage threshold during power loss		360.0/720.0	×	×
	b053	Deceleration time setting during power loss	0.01 to 99.99, 100.0 to 999.9, 1000. to 3600. (s)	1.00	×	×
	b054	Initial output frequency decrease during power loss	0.00 to 10.00 (Hz)	0.00	×	×
	b055	Proportional gain setting for nonstop operation at power loss	0.00 to 2.55	0.20	○	○
	b056	Integral time setting for nonstop operation at power loss	0.000 to 9.999 / 10.00 to 65.53 (s)	0.100	○	○
Window comparator	b060	Maximum-limit level of window comparators VRF	0. to 100. (lower limit : b061 + b062 * 2) (%)	100	○	○
	b061	Minimum-limit level of window comparators VRF	0. to 100. (lower limit : b060 - b062 * 2) (%)	0	○	○
	b062	Hysteresis width of window comparators VRF	0. to 10. (lower limit : b061 - b062 / 2) (%)	0	○	○
	b063	Maximum-limit level of window comparators IRF	0. to 100. (lower limit : b064 + b066 * 2) (%)	100	○	○
	b064	Minimum-limit level of window comparators IRF	0. to 100. (lower limit : b063 - b066 * 2) (%)	0	○	○
	b065	Hysteresis width of window comparators IRF	0. to 10. (lower limit : b063 - b064 / 2) (%)	0	○	○
	b066	Maximum-limit level of window comparators VRF2	-100. to 100. (lower limit : b067 + b068 * 2) (%)	100	○	○
	b067	Minimum-limit level of window comparators VRF2	-100. to 100. (lower limit : b066 - b068 * 2) (%)	0	○	○
	b068	Hysteresis width of window comparators VRF2	0. to 10. (lower limit : b066 - b067 / 2) (%)	0	○	○
	b070	Operation level at VRF disconnection	0. to 100. (%) or "no" (ignore)	no	×	○
	b071	Operation level at IRF disconnection		no	×	○
b072	Operation level at VRF2 disconnection	-100. to 100. (%) or "no" (ignore)		no	×	○
Others	b078	Cumulative input power data clearance	Clearance by setting "01" and pressing the STR key	00	×	○
	b079	Cumulative input power display gain setting	1. to 1000.	1.	○	○
	b082	Start frequency adjustment	0.10 to 9.99 (Hz)	0.50	×	○
	b083	Carrier frequency setting	0.5 to 15.0 (kHz) (subject to derating) <0.5 to 10.0 (kHz) (subject to derating)>	5.0 <3.0>	×	×
	b084	Initialization mode (parameters or trip history)	00 (clearing the trip history), 01 (initializing the data), 02 (clearing the trip history and initializing the data)	00	×	×
	b085	Country code for initialization	00 (Japan), 01 (EU), 02 (U.S.A.)	00	×	×
	b086	Frequency scaling conversion factor	0.1 to 99.0	1.0	○	○
	b087	STOP/RESET key enable	00 (enabling), 01 (disabling), 02 (disabling only the function to stop)	00	×	○
	b088	Restart mode after MBS	00 (starting with 0 Hz), 01 (starting with matching frequency), 02 (starting with active matching frequency)	00	×	○
	b089	Automatic carrier frequency reduction	00: invalid, 01: valid	00	×	×
	b090	Dynamic braking usage ratio	0.0 to 100.0 (%)	0.0	×	○
	b091	Stop mode selection	00 (deceleration until stop), 01 (free-run stop)	00	×	×
	b092	Cooling fan control	00 (always operating the fan), 01 (operating the fan only during inverter operation [including 5 minutes after power-on and inverter is stopped])	00	×	×
	b095	DBTR control	00 (disabling), 01 (enabling [disabling while the motor is topped]), 02 (enabling [enabling also while the motor is topped])	00	×	○
	b096	DBTR activation level	330 to 380, 660 to 760(V)	360/720	×	○
	b098	Thermistor for thermal protection control	00 (disabling the thermistor), 01 (enabling the thermistor with PTC), 02 (enabling the thermistor with NTC)	00	×	○
	b099	Thermal protection level setting	0. to 9999. (Ω)	3000	×	○

List of Functions

● Extension function b

Code	Name of function	Monitor/setting range	Initial setting	Setting possible during operation	Setting possible in the change mode during operation	
Free setting of V/F characteristic	b100	V/F frequency (1)	0. to "free-setting V/F frequency (2)" (Hz)	0.	×	×
	b101	V/F voltage (1)	0.0 to 800.0 (V)	0.0	×	×
	b102	V/F frequency (2)	0. to "free-setting V/F frequency (3)" (Hz)	0.	×	×
	b103	V/F voltage (2)	0.0 to 800.0 (V)	0.0	×	×
	b104	V/F frequency (3)	0. to "free-setting V/F frequency (4)" (Hz)	0.	×	×
	b105	V/F voltage (3)	0.0 to 800.0 (V)	0.0	×	×
	b106	V/F frequency (4)	0. to "free-setting V/F frequency (5)" (Hz)	0.	×	×
	b107	V/F voltage (4)	0.0 to 800.0 (V)	0.0	×	×
	b108	V/F frequency (5)	0. to "free-setting V/F frequency (6)" (Hz)	0.	×	×
	b109	V/F voltage (5)	0.0 to 800.0 (V)	0.0	×	×
	b110	V/F frequency (6)	0. to "free-setting V/F frequency (7)" (Hz)	0.	×	×
	b111	V/F voltage (6)	0.0 to 800.0 (V)	0.0	×	×
	b112	V/F frequency (7)	0. to 400. (Hz)	0.	×	×
b113	V/F voltage (7)	0.0 to 800.0 (V)	0.0	×	×	
Others	b120	Brake Control Enable	00 (disabling), 01 (enabling)	00	×	○
	b121	Brake Wait Time for Release	0.00 to 5.00 (s)	0.00	×	○
	b122	Brake Wait Time for Acceleration		0.00	×	○
	b123	Brake Wait Time for Stopping		0.00	×	○
	b124	Brake Wait Time for Confirmation		0.00	×	○
	b125	Brake Release Frequency Setting	0.00 to 99.99, 100.0 to 400.0 (Hz)	0.00	×	○
	b126	Brake Release Current Setting	0.0 to 2.00 x "rated current" <0.0 to 1.80 x "rated current">	Rated current of inverter	×	○
	b127	Braking frequency	0.00 to 99.99, 100.0 to 400.0 (Hz)	0.00	×	○
	b130	Overvoltage suppression enable	00 (disabling the restraint), 01 (controlled deceleration), 02 (enabling acceleration)	00	×	○
	b131	Overvoltage suppression level	330 to 390 (V) (200 V class model), 660 to 780 (V) (400 V class model)	380/760	×	○
	b132	Acceleration and deceleration rate at overvoltage suppression	0.10 to 30.00 (s)	1.00	×	○
	b133	Overvoltage suppression proportional gain	0.00 to 2.55	0.50	○	○
	b134	Overvoltage suppression Integral time	0.000 to 9.999 / 10.00 to 65.53 (s)	0.060	○	○

● Extension function C

Code	Name of function	Monitor/setting range	Initial setting	Setting possible during operation	Setting possible in the change mode during operation	
Multifunctional input terminals	C001	[RST] function (*2)	01 (RR: Reverse RUN), 02 (DFL: Multispeed 1 setting), 03 (DFM: Multispeed 2 setting), 04 (DFH: Multispeed 3 setting), 05 (DFHH: Multispeed 4 setting), 06 (JOG: Jogging), 07 (DB: external DC braking), 08 (BMD: Set B mode motor control),	18 (*2)	×	○
	C002	[ES] function	09 (AD2: 2-stage acceleration/deceleration), 11 (MBS: free-run stop), 12 (ES: external trip), 13 (USP: unattended start protection), 14 (CS: commercial power source enable), 15 (SFT: software lock), 16 (AUT: analog input voltage/current select), 17 (CMD: C mode motor control), 18 (RST: reset), 20 (STA: starting by 3-wire input), 21 (STP: stopping by 3-wire input), 22 (F/R: forward/reverse switching by 3-wire input), 23 (PID: PID disable), 24 (PIDC: PID reset), 26 (CAS: control gain setting), 27 (UP: remote control UP function), 28 (DWN: remote control DOWN function), 29 (DWN: remote control data clearing), 31 (OPE: forcible operation),	12	×	○
	C003	[JOG] function (*2)	32 (SF1: multispeed bit 1), 33 (SF2: multispeed bit 2), 34 (SF3: multispeed bit 3), 35 (SF4: multispeed bit 4), 36 (SF5: multispeed bit 5), 37 (SF6: multispeed bit 6), 38 (SF7: multispeed bit 7), 39 (OLR: stall prevention selection), 40 (TL: torque limit enable), 41 (TRQ1: torque limit selection bit 1), 42 (TRQ2: torque limit selection bit 2), 43 (PPI: P/PI mode selection), 44 (BOK: braking confirmation), 45 (ORT: orientation), 46 (LAC: LAD cancellation), 47 (PCLR: clearance of position deviation), 48 (STAT: pulse train position command input enable), 50 (ADD: trigger for frequency addition [A145]), 51 (F-TM: forcible-terminal operation), 52 (ATR: permission of torque command input), 53 (KHC: cumulative power clearance), 54 (SON: servo-on),	06 (*2)	×	○
	C004	[MBS] function	55 (FOC: forcing), 56 (MI1: general-purpose input 1), 57 (MI2: general-purpose input 2), 58 (MI3: general-purpose input 3), 59 (MI4: general-purpose input 4), 60 (MI5: general-purpose input 5), 61 (MI6: general-purpose input 6), 62 (MI7: general-purpose input 7), 63 (MI8: general-purpose input 8), 65 (AHD: analog command holding), 66 (CP1: multistage position settings selection 1), 67 (CP2: multistage position settings selection 2), 68 (CP3: multistage position settings selection 3), 69 (ORL: Zero-return limit function), 70 (ORG: Zero-return trigger function), 71 (FOT: forward drive stop), 72 (ROT: reverse drive stop), 73 (SPD: speed / position switching), 74 (PCNT: pulse counter), 75 (PCC: pulse counter clear), no (NO: no assignment)	11	×	○
	C005	[AD2] function		16	×	○
	C006	[DFM] function		03	×	○
	C007	[DFL] function		02	×	○
	C008	[RR] function		01	×	○
	C011	[RST] active state		00	×	○
	C012	[ES] active state		00	×	○
	C013	[JOG] active state		00	×	○
	C014	[MBS] active state		00	×	○
	C015	[AD2] active state		00	×	○
	C016	[DFM] active state		00	×	○
	C017	[DFL] active state		00	×	○
	C018	[RR] active state		00	×	○
	C019	[FR] active state		00	×	○

List of Functions

● Extension function C

Code	Name of function	Monitor/setting range	Initial setting	Setting possible during operation	Setting possible in the change mode during operation	
Multifunctional output terminals	C021	[UPF] function	00 (DRV: running), 01 (UPF1: constant-speed reached), 02 (UPF2: set frequency overreached), 03 (OL: current detection advance signal (1)), 04 (OD: output deviation for PID control), 05 (AL: alarm signal), 06 (UPF3: set frequency reached), 07 (OTQ: over-torque), 08 (IP: instantaneous power failure), 09 (UV: undervoltage), 10 (TRQ: torque limited), 11 (RNT: operation time over), 12 (ONT: plug-in time over), 13 (THM: thermal alarm signal), 19 (BRK: brake release), 20 (BER: braking error), 21 (ZS: 0 Hz detection signal), 22 (DSE: speed deviation maximum), 23 (POK: positioning completed), 24 (UPF4: set frequency overreached 2), 25 (UPF5: set frequency reached 2), 26 (OL2: current detection advance signal (2)), 27 (VDc: Analog VRF disconnection detection), 28 (IDc: Analog IRF disconnection detection), 29 (V2Dc: Analog VRF2 disconnection detection), 31 (FBV: PID feedback comparison), 32 (NDc: communication line disconnection), 33 (LOG1: logical operation result 1), 34 (LOG2: logical operation result 2), 35 (LOG3: logical operation result 3), 36 (LOG4: logical operation result 4), 37 (LOG5: logical operation result 5), 38 (LOG6: logical operation result 6), 39 (WAC: capacitor life warning), 40 (WAF: cooling-fan speed drop), 41 (FR: starting contact signal), 42 (OHF: heat sink overheat warning), 43 (LOC: low-current indication signal), 44 (M01: general-purpose output 1), 45 (M02: general-purpose output 2), 46 (M03: general-purpose output 3), 47 (M04: general-purpose output 4), 48 (M05: general-purpose output 5), 49 (M06: general-purpose output 6), 50 (IRDY: inverter ready), 51 (FRR: forward rotation), 52 (RRR: reverse rotation), 53 (MJA: major failure), 54(WCV: window comparator VRF), 55(WCI: window comparator IRF), 56 (WCV2: window comparator VRF2)	01	×	○
	C022	[DRV] function		00	×	○
	C023	[X1] function		13	×	○
	C024	[X2] function		07	×	○
	C025	[X3] function		08	×	○
	C026	Alarm relay function	(When alarm code output is selected for "C062", functions "AC0" to "AC2" or "AC0" to "AC3" [ACn: alarm code output] are forcibly assigned to multifunctional output terminals UPF to X1 or UPF to X2, respectively.)	05	×	○
Analog monitoring	C027	[FRQ] signal selection	00 (output frequency), 01 (output current), 02 (output torque), 03 (digital output frequency), 04 (output voltage), 05 (input power), 06 (electronic thermal overload), 07 (LAD frequency), 08 (digital current monitoring), 09 (motor temperature), 10 (heat sink temperature), 12 (general-purpose output YA0)	00	×	○
	C028	[AMV] signal selection	00 (output frequency), 01 (output current), 02 (output torque), 04 (output voltage), 05 (input power), 06 (electronic thermal overload), 07 (LAD frequency), 09 (motor temperature), 10 (heat sink temperature), 11 (output torque [signed value]), 13 (general-purpose output YA1)	00	×	○
	C029	[AMI] signal selection	00 (output frequency), 01 (output current), 02 (output torque), 04 (output voltage), 05 (input power), 06 (electronic thermal overload), 07 (LAD frequency), 09 (motor temperature), 10 (heat sink temperature), 14 (general-purpose output YA2)	00	×	○
	C030	Digital current monitor reference value	0.20 x "rated current" to 2.00 x "rated current" (A) (Current with digital current monitor output at 1,440 Hz)	Rated current of inverter	○	○
Multifunctional output terminals	C031	[UPF] active state	00 (NO) / 01 (NC)	00	×	○
	C032	[DRV] active state		00	×	○
	C033	[X1] active state		00	×	○
	C034	[X2] active state		00	×	○
	C035	[X3] active state		00	×	○
	C036	Alarm relay active state		01	×	○
Levels and output terminal status	C038	Low-current indication signal output mode selection	00 (output during acceleration/deceleration and constant-speed operation), 01 (output only during constant-speed operation)	01	×	○
	C039	Low-current indication signal detection level	0.0 to 2.00 x "rated current" (A) <0.0 to 1.80 x "rated current"(A)>	Rated current of inverter	○	○
	C040	Current detection signal output mode	00 (output during acceleration/deceleration and constant-speed operation), 01 (output only during constant-speed operation)	00	×	○
	C041	Current detection level setting	0.0 to 2.00 x "rated current" (A) <0.0 to 1.80 x "rated current"(A)>	Rated current of inverter	○	○
	C042	Frequency arrival setting for accel.	0.00 to 99.99, 100.0 to 400.0 (Hz)	0.00	×	○
	C043	Frequency arrival setting for decel.		0.00	×	○
	C044	PID deviation level setting	0.0 to 100.0 (%)	3.0	×	○
	C045	Frequency arrival setting for acceleration (2)	0.00 to 99.99, 100.0 to 400.0 (Hz)	0.00	×	○
	C046	Frequency arrival setting for deceleration (2)		0.00	×	○
	C052	Maximum PID feedback data	0.0 to 100.0 (%)	100.0	×	○
	C053	Minimum PID feedback data		0.0	×	○
	C055	Over-torque (forward-driving) level setting	0. to 200. (%) <0. to 180. (%)>	100.	×	○
	C056	Over-torque (reverse regenerating) level setting		100.	×	○
C057	Over-torque (reverse driving) level setting	100.		×	○	
C058	Over-torque (forward regenerating) level setting		100.	×	○	
C061	Electronic thermal warning level setting	0. to 100. (%)	85	×	○	
C062	Alarm code output	00 (disabling), 01 (3 bits), 02 (4 bits)	00	×	○	
C063	Zero speed detection level	0.00 to 99.99, 100.0 (Hz)	0.00	×	○	
C064	Heat sink overheat warning level	0. to 200.0 (C)	120.	×	○	

List of Functions

● Extension function C

Code	Name of function	Monitor/setting range	Initial setting	Setting possible during operation	Setting possible in the change mode during operation	
Communication function	C071	Communication speed selection	02 (loopback test), 03 (2,400 bps), 04 (4,800 bps), 05 (9,600 bps), 06 (19,200 bps)	04	×	○
	C072	Node allocation	1. to 32.	1.	×	○
	C073	Communication data length selection	7 (7 bits), 8 (8 bits)	7	×	○
	C074	Communication parity selection	00 (no parity), 01 (even parity), 02 (odd parity)	00	×	○
	C075	Communication stop bit selection	1 (1 bit), 2 (2 bits)	1	×	○
	C076	Selection of the operation after communication error	00 (tripping), 01 (tripping after decelerating and stopping the motor), 02 (ignoring errors), 03 (stopping the motor after free-running), 04 (decelerating and stopping the motor)	02	×	○
	C077	Communication timeout limit before tripping	0.00 to 99.99 (s)	0.00	×	○
	C078	Communication wait time	0. to 1000. (ms)	0.	×	○
	C079	Communication mode selection	00(ASCII), 01(Modbus-RTU)	00	×	○
Adjustment	C081	[VRF] input span calibration	0. to 9999., 1000 to 6553(10000 to 65530)	Factory setting	○	○
	C082	[IRF] input span calibration			○	○
	C083	[VRF2] input span calibration			○	○
	C085	Thermistor input tuning			0.0 to 999.9, 1000.	○
	C091	Debug mode enable	(Do not change this parameter, which is intended for factory adjustment.)		00	×
Others	C101	Up/Down memory mode selection	00 (not storing the frequency data), 01 (storing the frequency data)	00	×	○
	C102	Reset mode selection	00 (resetting the trip when RST is on), 01 (resetting the trip when RST is off), 02 (enabling resetting only upon tripping [resetting when RST is on]), 03(resetting only trip)	00	×	○
	C103	Restart mode after reset	00 (starting with 0 Hz), 01 (starting with matching frequency), 02 (restarting with active matching frequency)	00	×	○
Meter adjustment	C105	FRQ gain adjustment	50. to 200. (%)	100.	○	○
	C106	AMV gain adjustment		100.	○	○
	C107	AMI gain adjustment		100.	○	○
	C109	AMV bias adjustment	0. to 100. (%)	0.	○	○
	C110	AMI bias adjustment		20.	○	○
Level	C111	Current detection setting (2)	0.0 to 2.00 x "rated current" (A) <0.0 to 1.80 x "rated current" (A)>	Rated current of inverter	×	○
Adjustment	C121	[VRF] input zero calibration	0. to 9999., 1000 to 6553 (10000 to 65530)	Factory setting	○	○
	C122	[IRF] input zero calibration			○	○
	C123	[VRF2] input zero calibration			○	○

List of Functions

● Extension function C

Code	Name of function	Monitor/setting range	Initial setting	Setting possible during operation	Setting possible in the change mode during operation		
Output terminal operation function	C130	Output UPF on-delay time	0.0 to 100.0 (s)	0.0	×	○	
	C131	Output UPF off-delay time		0.0	×	○	
	C132	Output DRV on-delay time		0.0	×	○	
	C133	Output DRV off-delay time		0.0	×	○	
	C134	Output X1 on-delay time		0.0	×	○	
	C135	Output X1 off-delay time		0.0	×	○	
	C136	Output X2 on-delay time		0.0	×	○	
	C137	Output X2 off-delay time		0.0	×	○	
	C138	Output X3 on-delay time		0.0	×	○	
	C139	Output X3 off-delay time		0.0	×	○	
	C140	Output RY on-delay time		0.0	×	○	
	C141	Output RY off-delay time		0.0	×	○	
	C142	Logical output signal 1 selection 1		Same as the settings of C021 to C026 (except those of LOG1 to LOG6)	00	×	○
	C143	Logical output signal 1 selection 2			00	×	○
	C144	Logical output signal 1 operator selection	00 (AND), 01 (OR), 02 (XOR)	00	×	○	
	C145	Logical output signal 2 selection 1	Same as the settings of C021 to C026 (except those of LOG1 to LOG6)	00	×	○	
	C146	Logical output signal 2 selection 2		00	×	○	
	C147	Logical output signal 2 operator selection	00 (AND), 01 (OR), 02 (XOR)	00	×	○	
	C148	Logical output signal 3 selection 1	Same as the settings of C021 to C026 (except those of LOG1 to LOG6)	00	×	○	
	C149	Logical output signal 3 selection 2		00	×	○	
	C150	Logical output signal 3 operator selection	00 (AND), 01 (OR), 02 (XOR)	00	×	○	
	C151	Logical output signal 4 selection 1	Same as the settings of C021 to C026 (except those of LOG1 to LOG6)	00	×	○	
	C152	Logical output signal 4 selection 2		00	×	○	
	C153	Logical output signal 4 operator selection	00 (AND), 01 (OR), 02 (XOR)	00	×	○	
	C154	Logical output signal 5 selection 1	Same as the settings of C021 to C026 (except those of LOG1 to LOG6)	00	×	○	
	C155	Logical output signal 5 selection 2		00	×	○	
	C156	Logical output signal 5 operator selection	00 (AND), 01 (OR), 02 (XOR)	00	×	○	
	C157	Logical output signal 6 selection 1	Same as the settings of C021 to C026 (except those of LOG1 to LOG6)	00	√	○	
	C158	Logical output signal 6 selection 2		00	×	○	
	C159	Logical output signal 6 operator selection	00 (AND), 01 (OR), 02 (XOR)	00	×	○	
Input terminal response	C160	Input terminal response time setting RST	0. to 200. (X 2ms)	1	×	○	
	C161	Input terminal response time setting ES		1	×	○	
	C162	Input terminal response time setting JOG		1	×	○	
	C163	Input terminal response time setting MBS		1	×	○	
	C164	Input terminal response time setting AD2		1	×	○	
	C165	Input terminal response time setting DFM		1	×	○	
	C166	Input terminal response time setting DFL		1	×	○	
	C167	Input terminal response time setting RR		1	×	○	
	C168	Input terminal response time setting FR		1	×	○	
C169	Multistage speed/ position determination time	0. to 200. (X 10ms)	0	×	○		

List of Functions

● Extension function H

Code	Name of function	Monitor/setting range	initial setting	Setting possible during operation	Setting possible in the change mode during operation	
Control constants	H001	Auto-tuning Setting	00 (disabling auto-tuning), 01 (auto-tuning without rotation), 02 (auto-tuning with rotation)	00	×	×
	H002	Motor Setting	00 (Sumitomo general-purpose motor data), 01 (Sumitomo AF motor data), 02 (Sumitomo explosion proof motor data), 03 (auto-tuned data), 04 (auto-tuned data [with online auto-tuning function])	00	×	×
	H202	B mode motor Setting	00 (Sumitomo general-purpose motor data), 01 (Sumitomo AF motor data), 02 (Sumitomo explosion proof motor data), 03 (auto-tuned data), 04 (auto-tuned data [with online auto-tuning function])	00	×	×
	H003	Motor capacity	0.20 to 75.00 (kW)	Factory setting	×	×
	H203	Motor capacity, B mode motor			×	×
	H004	Motor poles setting	2, 4, 6, 8, 10 (poles)	4	×	×
	H204	Motor poles setting, B mode motor		4	×	×
	H005	Motor speed constant	0.001 to 9.999, 10.00 to 80.00 (10.000 to 80.000)	1.590	○	○
	H205	Motor speed constant, B mode motor		1.590	○	○
	H006	Motor stabilization constant	0. to 255.	100	○	○
	H206	Motor stabilization constant, B mode motor		100	○	○
	H306	Motor stabilization constant, C mode motor		100.	○	○
	H020	Motor constant R1	0.001 to 9.999, 10.00 to 65.53 (Ω)	Depending on motor capacity	×	×
	H220	Motor constant R1, B mode motor			×	×
	H021	Motor constant R2			×	×
	H221	Motor constant R2, B mode motor			×	×
	H022	Motor constant L			×	×
	H222	Motor constant L, B mode motor	0.01 to 99.99, 100.0 to 655.3 (mH)	×	×	
	H023	Motor constant lo	0.01 to 99.99, 100.0 to 655.3 (A)	×	×	
	H223	Motor constant lo, B mode motor		×	×	
	H024	Motor constant J	0.001 to 9.999, 10.00 to 99.99, 100.0 to 999.9, 1000. to 9999.	×	×	
	H224	Motor constant J, B mode motor		×	×	
	H030	Auto-tuning constant R1	0.001 to 9.999, 10.00 to 65.53 (Ω)	Depending on motor capacity	×	×
	H230	Auto-tuning constant R1, B mode motor			×	×
	H031	Auto-tuning constant R2			×	×
	H231	Auto-tuning constant R2, B mode motor			×	×
	H032	Auto-tuning constant L			×	×
	H232	Auto-tuning constant L, B mode motor	0.01 to 99.99, 100.0 to 655.3 (mH)	×	×	
	H033	Auto-tuning constant lo	0.01 to 99.99, 100.0 to 655.3 (A)	×	×	
	H233	Auto-tuning constant lo, B mode motor		×	×	
	H034	Auto-tuning constant J	0.001 to 9.999, 10.00 to 99.99, 100.0 to 999.9, 1000. to 9999.	×	×	
	H234	Auto-tuning constant J, B mode motor		×	×	
Control constants	H050	PI proportional gain	100.0	○	○	
	H250	PI proportional gain for B mode moto	100.0	○	○	
	H051	PI integral gain	0.0 to 999.9, 1000.	100.0	○	○
	H251	PI integral gain for B mode motor		100.0	○	○
	H052	P proportional gain setting	0.01 to 10.00	1.00	○	○
	H252	P proportional gain setting for B mode motor		1.00	○	○
	H060	Zero SLV limit	0.0 to 100.0	100.0	○	○
	H260	Zero SLV limit for B mode motor		100.0	○	○
	H061	Zero SLV starting boost	0. to 50. (%)	50.	○	○
	H261	Zero SLV starting boost current for B mode motor		50.	○	○
	H070	Terminal selection PI proportional gain setting	0.0 to 999.9, 1000.	100.0	○	○
	H071	Terminal selection PI integral gain setting		100.0	○	○
	H072	Terminal selection P proportional gain setting	0.00 to 10.00	1.00	○	○
H073	Gain switching time	0. to 9999. (ms)	100.	○	○	

List of Functions

● Extension function P

Code	Name of function	Monitor/setting range	Initial setting	Setting possible during operation	Setting possible in the change mode during operation	
Optional functions	P001	Operation mode on expansion card 1 error	00 (tripping), 01 (continuing operation)	×	○	
	P002	Operation mode on expansion card 2 error		×	○	
	P011	PG pulse-per-revolution (PPR) setting	128. to 9999., 1000 to 6553(10000 to 65535) (pulses)	1024.	×	×
	P012	Control mode setting	00 (ASR), 01 (APR), 02 (APR2), 03 (HAPR)	00	×	×
	P013	Pulse train mode setting	00 (mode 0), 01 (mode 1), 02 (mode 2)	00	×	×
	P014	Home search stop position setting	0. to 4095.	0.	×	○
	P015	Home search speed setting	"start frequency" to "maximum frequency" (up to 120.0) (Hz)	5.00	×	○
	P016	Home search direction setting	00 (forward), 01 (reverse)	00	×	×
	P017	Home search completion range setting	0. to 9999., 1000 (10000) (pulses)	5.	×	○
	P018	Home search completion delay time setting	0.00 to 9.99 (s)	0.00	×	○
	P019	Electronic gear set position selection	00 (feedback side), 01 (commanding side)	00	×	○
	P020	Electronic gear ratio numerator setting	0. to 9999.	1.	○	○
	P021	Electronic gear ratio denominator setting		1.	○	○
	P022	Feed-forward gain setting	0.00 to 99.99, 100.0 to 655.3	0.00	○	○
	P023	Position loop gain setting	0.00 to 99.99, 100.0	0.50	○	○
	P024	Position bias setting	-204 (-2048.) / -999. to 2048.	0.	○	○
	P025	Temperature compensation thermistor enable	00 (no compensation), 01 (compensation)	00	×	○
	P026	Over-speed error detection level setting	0.0 to 150.0 (%)	135.0	×	○
	P027	Speed deviation error detection level setting	0.00 to 99.99, 100.0 to 120.0 (Hz)	7.50	×	○
	P028	Numerator of motor gear ratio	0. to 9999.	1.	×	○
	P029	Denominator of motor gear ratio		1.	×	○
	P031	Accel/decel time input selection	00 (digital operator), 01 (option 1), 02 (option 2), 03 (easy sequence)	00	×	×
	P032	Positioning command input selection	00 (digital operator), 01 (option 1), 02 (option 2)	00	×	○
	P033	Torque command input selection	00 (VRF terminal), 01 (IRF terminal), 02 (VRF2 terminal), 03 (digital operator)	00	×	×
	P034	Torque command setting	0. to 200. (%) <0. to 180. (%)>	0.	○	○
	P035	Polarity selection at the torque command input via VRF2 terminal	00 (as indicated by the sign), 01 (depending on the operation direction)	00	×	×
	P036	Torque bias mode	00 (disabling the mode), 01 (digital operator), 02 (input via VRF2 terminal)	00	×	×
	P037	Torque bias value	-200. to +200. (%) <-180. to 180. (%)>	0.	○	○
	P038	Torque bias polarity selection	00 (as indicated by the sign), 01 (depending on the operation direction)	00	×	×
	P039	Speed limit for torque-controlled operation (forward rotation)	0.00 to "maximum frequency" (Hz)	0.00	○	○
	P040	Speed limit for torque-controlled operation (reverse rotation)		0.00	○	○
	P044	DeviceNet comm watchdog timer	0.00 to 99.99 (s)	1.00	×	×
	P045	Inverter action on DeviceNet comm error	00 (tripping), 01 (tripping after decelerating and stopping the motor), 02 (ignoring errors), 03 (stopping the motor after free-running), 04 (decelerating and stopping the motor)	01	×	×
	P046	DeviceNet polled I/O: Output instance number	20, 21, 100	21	×	×
P047	DeviceNet polled I/O: Input instance number	70, 71, 101	71	×	×	
P048	Inverter action on DeviceNet idle mode	00 (tripping), 01 (tripping after decelerating and stopping the motor), 02 (ignoring errors), 03 (stopping the motor after free-running), 04 (decelerating and stopping the motor)	01	×	×	
P049	DeviceNet motor poles setting for r/min	0, 2, 4, 6, 8, 10, 12, 14, 16, 18, 20, 22, 24, 26, 28, 30, 32, 34, 36, 38 (poles)	0	×	×	
P055	Pulse-train frequency scale	1.0 to 50.0 (kHz)	25.0	×	○	
P056	Time constant of pulse-train frequency filter	0.01 to 2.00 (s)	0.10	×	○	
P057	Pulse-train frequency bias	-100. to +100. (%)	0.	×	○	
P058	Pulse-train frequency limit	0. to 100. (%)	100.	×	○	
Absolute position control	P060 to P067	Multistage position setting 0 to 7	Position setting range reverse side to forward side (upper 4 digits including "-")	0	○	○
	P068	Zero-return mode selection	00(Low) / 01 (Hi1) / 00 (Hi2)	00	○	○
	P069	Zero-return direction selection	00 (FR) / 01 (RR)	00	○	○
	P070	Low-speed zero-return frequency	0.00 to 10.00 (Hz)	0.00	○	○
	P071	High-speed zero-return frequency	0.00 to 99.99 / 100.0 to Maximum frequency setting (Hz)	0.00	○	○
	P072	Position range specification (forward)	0 to 268435455 (when P012 = 02) 0 to 1073741823 (when P012 = 03) (upper 4 digits)	268435455	○	○
	P073	Position range specification (reverse)	-268435455 to 0 (when P012 = 02) -1073741823 to 0 (when P012 = 03) (upper 4 digits)	-268435455	○	○
	P074	Teaching selection	00 (X00), 01 (X01), 02 (X02), 03 (X03), 04 (X04), 05 (X05), 06 (X06), 07 (X07)	00	○	○

● Extension function U

Code	Name of function	Monitor/setting range	Initial setting	Setting possible during operation	Setting possible in the change mode during operation
U001 to U012	User-selected function 1	no, d001 to P131	no	×	×

Terminal function

Main circuit terminal

Terminal function

Terminal code	Terminal name	Function
R,S,T	Main power input	Connect to the input power.
U,V,W	Inverter output	Connect to 3-phase motor.
P,PR	External braking resistor connection	Connect to braking resistor (option). (For 22 kW or less)
P,N,	External braking unit connection	Connect to a braking unit (option).
P1,P	DC reactor connection	Connect to a DC reactor (DCL).
E (G)	Grounding wire connection	Ground (Ground the equipment for prevention of electric shock and noise reduction.)
r1,t1	Control power input	Connect to an input power supply.

Terminal arrangement

● HF4312-5A5-N, HF4304-5A5-N

● HF4312-5A5 to 011, HF4314-5A5 to 011

● HF4312-015, 022, HF4314-015, 022

● HF4312-030, 037, HF4314-030, 037

● HF4312-045, HF4314-045, 055

● HF4312-055

Terminal thread diameter/terminal width

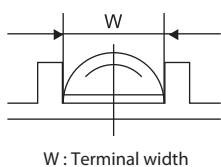

Model No.	Terminal thread diameter	E (G)	Terminal width
HF 4312, HF 4314-5A5-N	M4	M4	13
HF 4312, HF 4314-5A5, 7A5	M5	M5	18
HF 4312, HF 4314-011	M6	M5	18
HF 4312-015, HF 4314-015 to 030	M6	M6	23
HF 4312-022, 030	M8	M6	23
HF 4312-037, 045, HF 4314-037 to 055	M10	M8	29
HF 4312-055	M10	M8	40
r1, t1 terminal	M4	-	9

Control circuit terminal

Terminal arrangement

+V	VRF2	AMV	FRQ	TH	FR	RR	BC	AUT	JOG	RST	X2	X1	UPF	FB	
COM	VRF	IRF	AMI	P24	PCS	BC	DFL	DFM	MBS	ES	X3	OM	DRV	FC	FA

Terminal function

Control circuit terminal

Terminal function

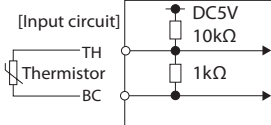
		Terminal code	Terminal name	Setting range	Electric characteristics		
Analog	Power	COM	Analog common	Common for analog input (VRF, VRF2, IRF) and analog output (AMV, AMI). *Do not ground to earth.	-		
		+V	Power supply for frequency setting	10 VDC power supply for VRF terminal	Allowable load current: 20 mA or less		
	Frequency setting input	VRF	Frequency command	Max. frequency at 10 VDC when 0-10 VDC is input. Set A014 if max. frequency corresponds to voltage below 10 VDC.	Input impedance: 10Ω Allowable input voltage range: -0.3 to +12 VDC		
		VRF2	Frequency command auxiliary terminal	VRF2 is a ±10 VDC signal. Use VRF2 for either an auxiliary signal added to VRF or IRF or as the main frequency reference. The that codes the direction with the voltage polarity.	Input impedance: 10Ω Allowable input voltage range: 0 to ±12 VDC		
		IRF	Frequency command (Current)	Max. frequency at 20 mADC when 4-20 mADC is input. The IRF signal is valid only when the AUT terminal is ON.	Input impedance: 100Ω Allowable input current range: 0 to 24 mADC		
	Monitor output	AMV	Analog voltage output monitor	Select one of the monitor items for either output – output frequency, output current, torque, output voltage, input power, and electronic thermal load factor.	0-10 VDC voltage output Allowable load current: 2 mA or less		
AMI		Analog current output monitor	4-20 mADC current output Allowable load impedance: 250Ω or less				
Digital	Monitor output	FRQ	Digital monitor	[0-10 VDC voltage output (PWM output method)] Select and input one of the monitor items – output frequency, output current, torque, output voltage, input power, and electronic thermal load factor. [Digital pulse output (Pulse voltage 0/10 VDC)] Use this method to output a pulse signal with a frequency that scales to the monitor item (duty 50%).	Allowable load current: 1.2 mA or less Digital output frequency range: 0-3.6 kHz 0-3.6 kHz		
	Power	P24	Power supply for interface	24 VDC power supply for contact input Contact input common when sourcing output logic is selected	Allowable load current: 100 mA or less		
		BC	Common for interface	Common terminal for power P24 terminal, thermistor input TH terminal, and digital monitor FRQ terminal for interface. Contact input common when the sinking output logic is selected. Do not ground to earth.	-		
	Contact input	Operation command	FR	Forward operation command	FR signal ON for forward run command, and OFF for stop command	[Condition for contact input ON] Voltage between each input and PCS: 18 VDC or more	
			RST ES JOG MBS AD2 DFM DFL RR	Multifunctional input	8 inputs programmable from the functions reverse rotation command, multistep speed 1-4, jogging, external DC braking, B mode, No.2 acceleration/deceleration, free run stop, external error, USP function, commercial power changeover, software lock, analog input changeover, C mode, error reset, 3-wire activation, 3-wire holding, 3-wire forward/reverse, PID valid/invalid, PID integral reset, remote control speed up, remote control slow down, remote control data clear, multistep bit 1-7, overload limit changeover, and no allocation.	[Condition for contact input OFF] Voltage between each input and PCS: 3 VDC or less Input impedance Between each input and PCS: 4.7 kΩ	
		PCS	Common for multifunctional input	The input logic type can be selected from either sinking output or sourcing output using the PCS terminal. For sinking output type input logic connect the shorting bar between P24 and PCS terminals. For sourcing output type input logic connect the shorting bar between PCS and BC and use P24 or external power to drive the inputs.	Allowable max. voltage Between each input and PCS: 27 VDC		
	Open collector output	State/factor	UPF DRV X1 X2 X3	Multifunctional output	The 5 output terminals available are programmable for various functions. When alarm code is selected with C062, the output terminals UPF-X2 (3-bits) or the output terminals UPF-X3 terminals (4-bits) generate alarm codes. The output terminals and OM terminal are hardwired for both sourcing and sinking type output signals.	Between output terminals and OM Voltage drop of 4 V or less at ON Allowable max. voltage: 27 VDC Allowable max. current: 50 mA	
			OM	Common for multifunctional output	Common terminal for multifunctional output terminals		
	Analog	Analog input	Sensor	TH	Thermistor input	When the external thermistor is connected and the temperature fault occurs, the external thermistor trips the inverter. The BC terminal is the common terminal. [Recommended thermistor characteristics] Allowable rated power: 100 mW or more, impedance during temperature error: 3kΩ. Detection level of temperature error is variable within the range between 0 and 9999Ω.	Allowable input voltage range DC0-5V 
	Digital	Relay contact output	State/alarm	FA FB FC	Alarm output	Function of output is programmable. Output is FORM C type relay output. The default function for this output is ALARM indicating that the protection feature tripped the drive and shut down motor operation. Max. contact capacity FB-FC 250 VAC, 2A (resistance)/0.2 A (induction) FA-FC 250 VAC, 2A (resistance)/0.2 A (induction) Min. contact capacity AC100V, 10mA DC5V, 100mA	

Standard Connection Diagram

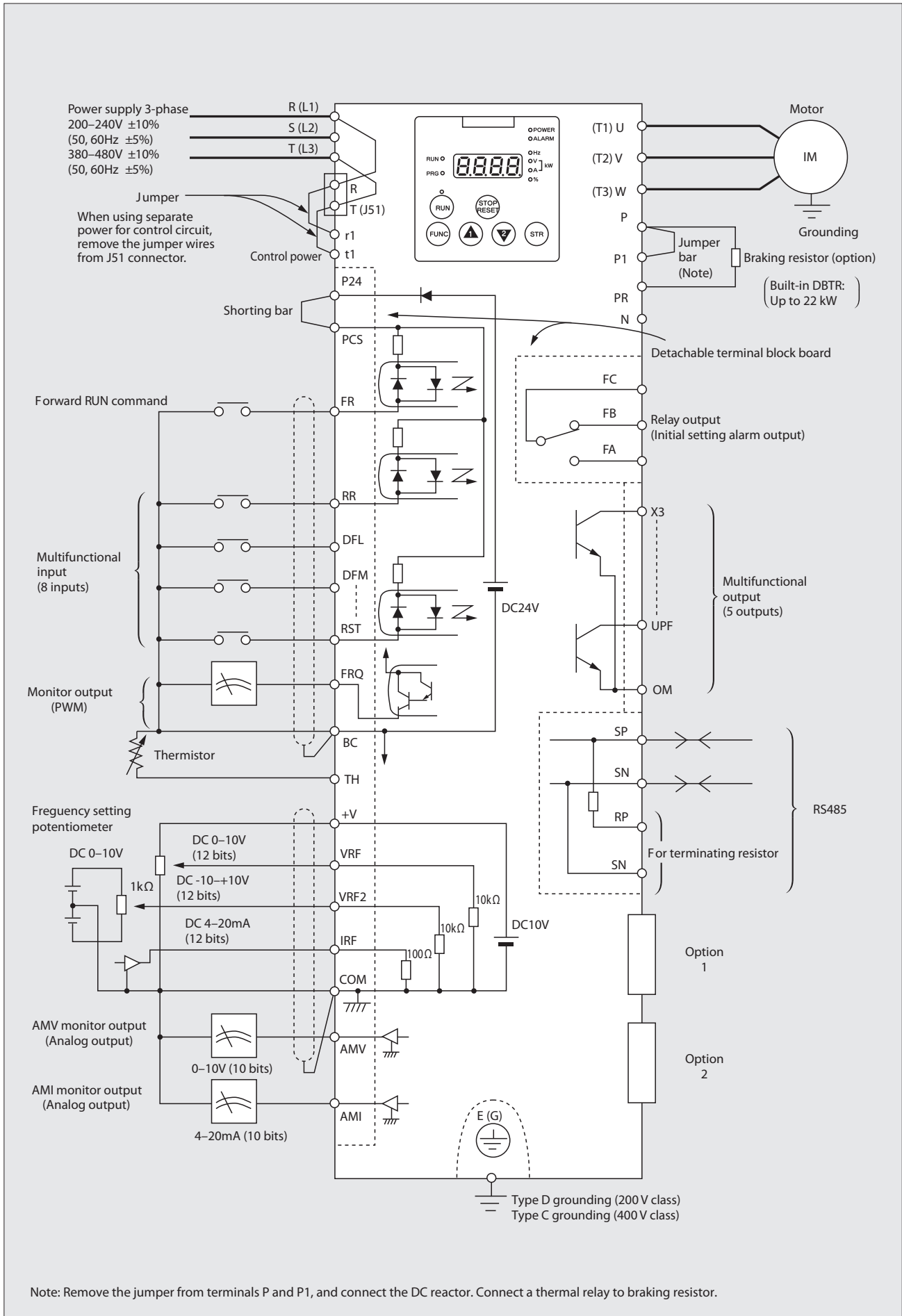

Note: Remove the jumper from terminals P and P1, and connect the DC reactor. Connect a thermal relay to braking resistor.

Applicable Wiring for Accessories Options

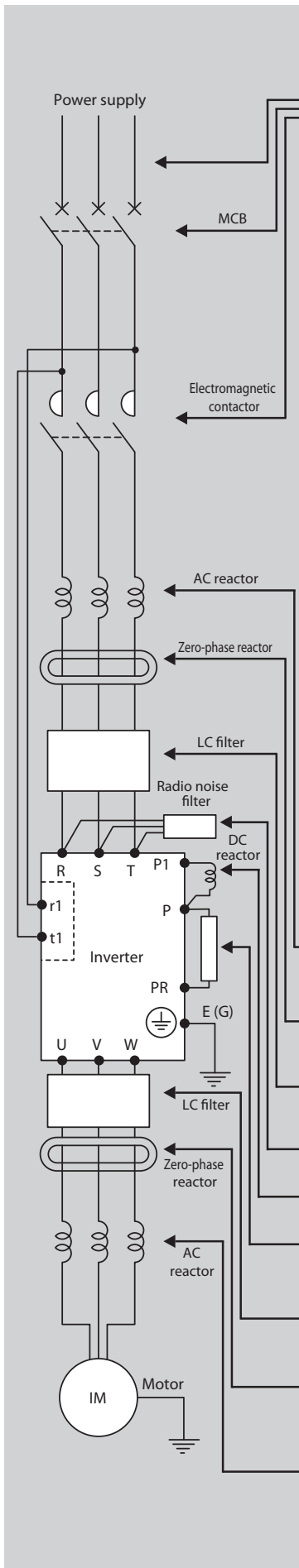

Standard Accessories

Rated input voltage	Applicable motor rating	Applicable inverter model	Circuit breaker and earth leakage breaker (Made by Mitsubishi Electric)		Electromagnetic contactor [MCJ] (Made by Fuji Electric)		Cable size (mm ²) (Note)	
			No reactor		No reactor	No reactor	No reactor	Inverter output side
200 V class	5.5	HF4312-5A5, 5A5-N	NF50, NV50	50A	SC-1N	8 (5.5)	5.5 (5.5)	
	7.5	HF4312-7A5	NF100, NV100	60A	SC-2N	14 (8)	8 (8)	
	11	HF4312-011	NF100, NV100	75A	SC-2SN	22 (14)	14 (14)	
	15	HF4312-015	NF100, NV100	100A	SC-3N	38 (14)	22 (14)	
	22	HF4312-022	NF225, NV225	175A	SC-5N	60 (22)	38 (22)	
	30	HF4312-030	NF225, NV225	200A	SC-7N	38 ^{*2} (38)	60 (30)	
	37	HF4312-037	NF400, NV400	250A	SC-8N	50 ^{*2} (50)	50 ^{*2} (38)	
400 V class	45	HF4312-045	NF400, NV400	300A	SC-10N	60 ^{*2} (60)	38 ^{*2} (50)	
	55	HF4312-055	NF400, NN400	350A	SC-11N	80 ^{*2} (38 ^{*2})	60 ^{*2} (60)	
	5.5	HF4314-5A5, 5A5-N	NF30, NV30	30A	SC-5-1	5.5 (2)	3.5 (3.5)	
	7.5	HF4314-7A5	NF30, NV30	30A	SC-5-1	5.5 (2)	3.5 (3.5)	
	11	HF4314-011	NF50, NV50	50A	SC-1N	8 (3.5)	5.5 (3.5)	
	15	HF4314-015	NF100, NV100	60A	SC-2N	14 (5.5)	8 (5.5)	
	22	HF4314-022	NF100, NV100	100A	SC-2SN	30 (5.5)	14 (8)	
	30	HF4314-030	NF225, NV225	125A	SC-3N	38 (14)	22 (14)	
	37	HF4314-037	NF225, NV225	150A	SC-4N	60 (22)	38 (14)	
	45	HF4314-045	NF225, NV225	175A	SC-5N	30 ^{*2} (30)	50 (22)	
55	HF4314-055	NF225, NV225	200A	SC-7N	38 ^{*2} (38)	60 (30)		

- Notes: 1. Type of cable: 600 V IV cable. 600 V crosslinked-polyethylene-insulated cable is shown in parentheses.
 2. The above types may change depending on the operating environment.
 3. Use thicker cables when wiring distance exceeds 20 m.
 4. The shown accessories are for use with SUMITOMO 3-phase, 4-pole motors.

When using an earth leakage breaker (ELB), select the breaker's trip current from the table below based on the total wire distance (ℓ) by summing the distance from the breaker to the inverter and the inverter to the motor.

ℓ	Trip current (mA)
100m or less	30
300m or less	100
600m or less	200

- Notes: 1. When CV wiring is used in metal conduit, the leakage current is approximately 30mA/km.
 2. Leakage current will increase eightfold with IV type cable due to higher dielectric constant. In this case, use ELB with the next higher trip rating.

Name	Function
Input AC reactor	This is useful in suppressing harmonics induced on the power supply lines, or when the main power voltage imbalance exceeds 3%, (and power source capacity is more than 500kVA), or to smooth out line fluctuations. It also improves the power factor.
Zero-phase reactor	Electrical noise interference may occur on nearby equipment such as a radio receiver. This magnetic choke filter helps reduce radiated noise.
Input noise filter LC filter	This filter reduces the conducted noise in the power supply wiring between the inverter and the power distribution system. Connect it to the inverter primary (input side).
Input radio noise filter (XY filter)	This capacitive filter reduces radiated noise from the main power wires in the inverter input side.
DC reactor	The inductor or choke filter suppresses harmonics generated by the inverter.
Regenerative braking resistor	The regenerative braking resistor is useful for increasing the inverter's control torque for high duty-cycle (on-off) applications, and improving the decelerating capacity.
Output noise filter LC filter	This filter reduces radiated noise emitted on the inverter output cable that may interfere with radio or television reception and test equipment and sensor operation.
Zero-phase reactor	Electrical noise interference may occur on nearby equipment such as a radio receiver. This magnetic choke filter helps reduce radiated noise.
Output AC reactor	Install the reactor on the output side to reduce leakage current contributed by high harmonics. Contact our company for details.

Note: Ground the LC filter according to the operation manual. Incorrect grounding will lessen the effectiveness.

Peripheral Equipment

■ Caution in Selecting Peripheral Equipment

Wiring and connection		<ol style="list-style-type: none"> 1. Be sure to connect the power supply to RST (input terminals) and the motor to U, V, W (output terminals). 2. Be sure to connect the grounding terminal.(mark) <p>Inverters generate high frequency, increasing leakage current. Be sure to ground the inverter and motor.</p>
Wiring between inverter and motor	Electromagnetic contactor	When using an electromagnetic contactor between the inverter and motor, do not turn the contactor ON or OFF during inverter operation.
	Thermal relay	<p>Install a thermal relay that matches the motor in the following cases:</p> <p>*Install a thermal relay for each motor when operating more than one motor with one inverter.</p> <p>*Set the current of the thermal relay at the rated motor current x 1.1. When the wiring length is long (more than 10 m), the thermal relay may be activated too quickly. Install an AC reactor or current sensor on the output side.</p> <p>*When motors are to be operated with the rated current exceeding the adjustable level of the built-in electronic thermal relay.</p>
Earth leakage breaker		<p>Install an earth leakage breaker on the input side for protection of the inverter wiring and operators.</p> <p>Conventional earth leakage breakers may malfunction because of high harmonics from the inverter; therefore use an earth leakage breaker that is applicable to the inverter. The leakage current differs according to the cable length. Refer to p.14.</p>
Wiring distance		<p>The wiring distance between the inverter and operation panel should be less than 30m. If it exceeds 30m, use a current/voltage converter, etc. Use shielded cable for wiring.</p> <p>When the wiring distance between the motor and inverter is long, the leakage current from high harmonics may cause the protective function of the inverter and peripheral equipment to be activated.</p> <p>The situation will be improved by an AC reactor installed on the output side of the inverter.</p> <p>Select appropriate cable to prevent voltage drop. (Large voltage drop lowers the torque.)</p>
Phase-advanced capacitor		<p>Do not use a phase-advanced capacitor.</p> <p>When a power factor improving capacitor is connected between the inverter and motor, the capacitor may be heated or broken by the higher harmonics in the inverter output.</p>

Braking Unit and Braking Resistor

Selection table for braking unit and braking resistor

Selection table

Voltage	Model of inverter	Motor rating (kW)	Braking torque 100%							
			Operation rate : 4%ED Braking time : 7 sec. or less				Operation rate : 10%ED Braking time : 15 sec. or less			
			Braking unit		Braking resistor Note 2		Braking unit		Braking resistor Note 2	
			Type	Min. Ω	Type	Qty.	Type	Min. Ω	Type	Qty.
200V Class	HF4312-5A5, 5A5-N	5.5	Note 1	-	Y135AA208(70Ω 400W) Note 3	2P	Note 1	-	X435AC069(10Ω 750W)	2S
	HF4312-7A5	7.5		-	X435AC069(10Ω 750W)	2S		-	X435AC069(10Ω 750W)	2S
	HF4312-011	11		-	X435AC069(10Ω 750W) Note 4	2S		-	X435AC094(7Ω 750W) Note 4	3S
	HF4312-015	15		-	X435AC064(2.5Ω 750W)	3S		-	X435AC064(2.5Ω 750W)	4S
	HF4314-022	18.5		-	X435AC064(2.5Ω 750W)	3S		-	X435AC054(1.5Ω 750W)	5S
	HF4312-022	22		-	X435AC054(1.6Ω 750W)	4S		-	X435AC065(1.1Ω 750W)	6S
	HF4312-030	30	BRD-E3-30K	4 Ω	X435AC065(1.1Ω 750W)	4S	BRD-E3-30K	4 Ω	X435AC066(0.6Ω 750W)	8S
	HF4312-037	37	BRD-E3-55K	2 Ω	X435AC065(1.1Ω 750W)	4S	BRD-E3-55K	2 Ω	X435AC054(1.6Ω 750W)	5S×2P
	HF4312-045	45		2 Ω	X435AC054(1.6Ω 750W)	3S×2P		2 Ω	X435AC065(1.1Ω 750W)	6S×2P
	HF4312-055	55		2 Ω	X435AC054(1.6Ω 750W)	3S×2P		2 Ω	X435AC066(0.6Ω 750W)	8S×2P
400V Class	HF4314-5A5, 5A5-N	5.5	Note 1	-	Y135AA205(200Ω 300W)	2P	Note 1	-	Y135AA209(250Ω 400W)	3P
	HF4314-7A5	7.5		-	Y135AA153(30Ω 400W)	2S		-	Y435AC058(250Ω 750W)	2S
	HF4314-011	11		-	Y435AC058(30Ω 750W) Note 5	2S		-	Y435AC103(20Ω 750W)	3S
	HF431v-015	15		-	Y435AC069(10Ω 750W)	3S		-	Y435AC069(10Ω 750W)	4S
	HF4314-022	18.5		-	Y435AC069(10Ω 750W)	3S		-	Y435AC063(4.5Ω 750W)	6S
	HF4314-022	22		-	Y435AC090(6Ω 750W)	4S		-	Y435AC063(4.5Ω 750W)	6S
	HF4314-030	30	BRD-EZ3-30K	10 Ω	Y435AC063(4.5Ω 750W)	4S	BRD-EZ3-30K	10 Ω	Y435AC064(2.5Ω 750W)	8S
	HF4314-037	37		10 Ω	Y435AC064(2.5Ω 750W)	4S		10 Ω	Y435AC054(1.6Ω 750W)	10S
	HF4314-045	45		10 Ω	Y435AC064(2.5Ω 750W)	5S		10 Ω	Y435AC065(1.1Ω 750W)	12S
	HF4314-055	55		10 Ω	Y435AC094(7Ω 750W)	3S×2P		10 Ω	Y435AC064(2.5Ω 750W)	8S×2P

- Note: 1. A braking unit is unnecessary because a braking circuit is built in the inverter. Use an external thermal relay for protection of the resistor from heating. When the thermal relay is activated, turn off the input power of the inverter. Set the usage rate with inverter parameters for protection from overloading.
2. P in the column of the number of resistors means parallel connection and S means series connection.
 3. Braking torque Approx. 70%.
 4. Braking torque Approx. 80%.
 5. Braking torque Approx. 90%.

Wire size (Terminal P/PR/N)

Model of inverter	Wire
HF4312-5A5, 5A5-N	5.5mm ² or more
HF4312-7A5	8mm ² or more
HF4312-011	14mm ² or more
HF4312-015	22mm ² or more
HF4312-022	30mm ² or more
HF4314-5A5, 5A5-N HF4314-7A5	3.5mm ² or more
HF4314-011	3.5mm ² or more
HF4314-015	8mm ² or more
HF4314-022	14mm ² or more

Model of braking unit	Resistor	Wire	SL1,SL2, MA1,MA2	Ground
BRD-E3-30K	8 Ω or more	5.5mm ² or more	0.75mm ² or more	5.5mm ² or more
	5 to 7.9 Ω	8mm ² or more		
	4 to 4.9 Ω	14mm ² or more		
BRD-E3-55K	4 Ω or more	14mm ² or more		
	3 to 3.9 Ω	22mm ² or more		
BRD-EZ3-30K	2 to 2.9 Ω	38mm ² or more		
	17 Ω or more	3.5mm ² or more		
	13 to 16.9 Ω	5.5mm ² or more		
	10 to 12.9 Ω	8mm ² or more		

- Note: 1. The maximum temperature of the braking resistor is approx. 150°C. Use heat-resistant wire. When installing the resistor pay close attention to the location with regards to clearance from heat sensitive elements.
2. The maximum wire length shall be 5 m. Twist the wire.
 3. Improper connection of P, N, and PR will lead to failure of the inverter and braking unit. Make sure that the same terminal codes are connected.
 4. The braking resistor may become hot during operation. Do not touch it directly with bare hands.

Braking Unit and Braking Resistor

Connection Drawing for Braking Unit and Braking Resistor

① One Braking Unit

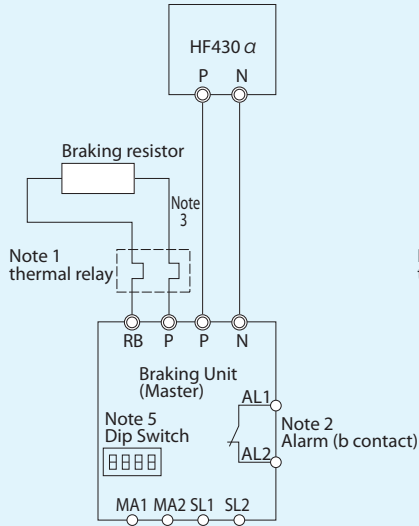

② Two Braking Units

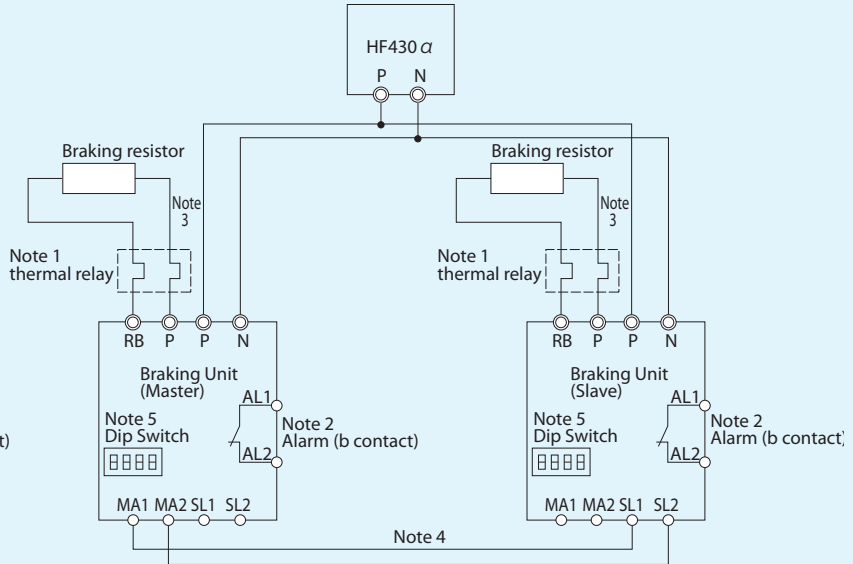

- Note: 1. Connect a thermal relay to braking resistor and when operating, please cut the power supply of the inverter off.
- 2. Connect an alarm output(AL1 and AL2) for overheating prevention of the braking unit and cut the power supply of the inverter off.
- 3. Use a twisted cable for the wiring of the braking resistor within the 5m.
- 4. Use a twisted cable for wiring of MA1, MA2 And SL1,SL2.
- 5. Operation voltage level of the braking unit is setting by DIP switch. (The master and slave of the braking units)

Setting for DIP Switch				Function Setting	Remarks	
1	2	3	4	ON OFF	Master Operation Voltage : 363V(725V)	Factory setting
OFF	OFF	ON	×			
1	2	3	4	ON OFF	Master Operation Voltage : 345V(689V)	
ON	OFF	ON	×			
1	2	3	4	ON OFF	Master Operation Voltage : 326V(653V)	
ON	ON	ON	×			
1	2	3	4	ON OFF	Slave	Operation voltage depends on setting of muster unit.
×	×	OFF	×			

() Values shown here are too 400V class drives.

Operating rate %ED

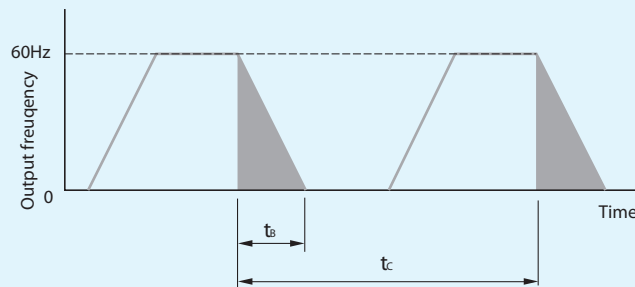

$$\text{Operating rate \%ED} = \frac{t_b}{t_c} \times 100$$

t_b = Braking time (sec)

t_c = Cycle time (sec)

Outline Drawing of Braking Unit

Braking Unit

BRD-EZ3-30K

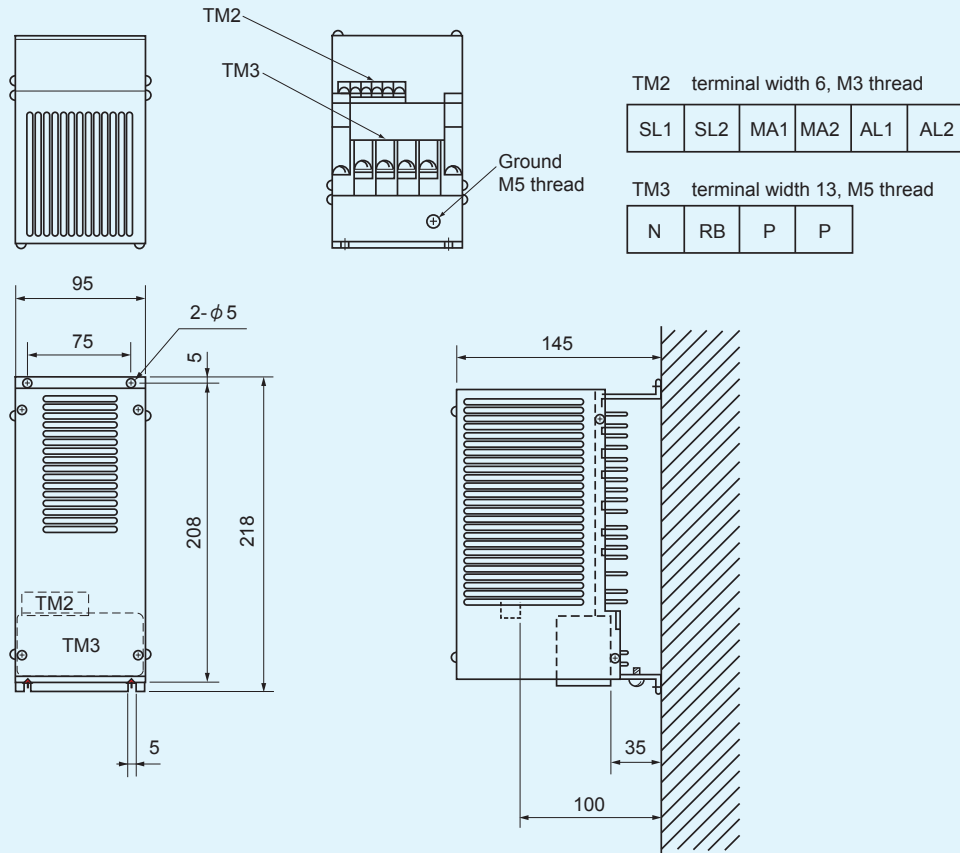

BRD-E3-30K

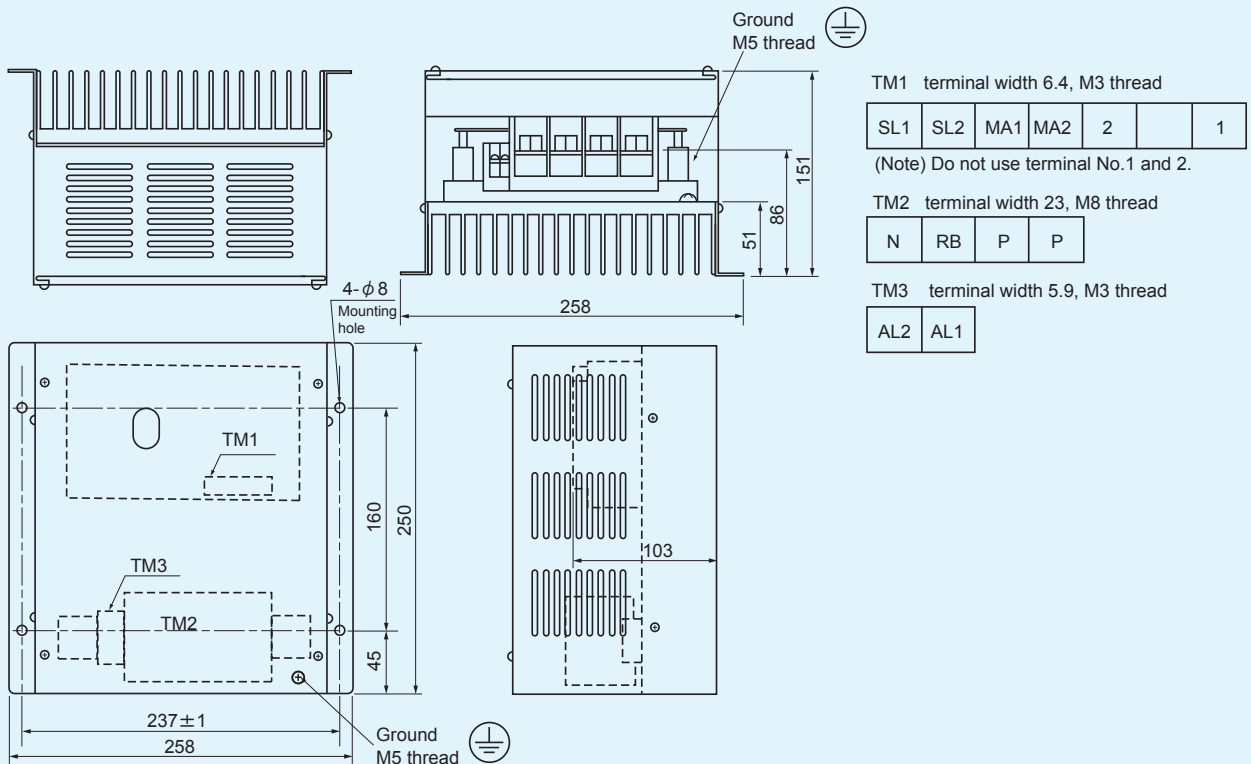

Outline Drawing of Braking Unit and Braking Resistor

BRD-E3-55K

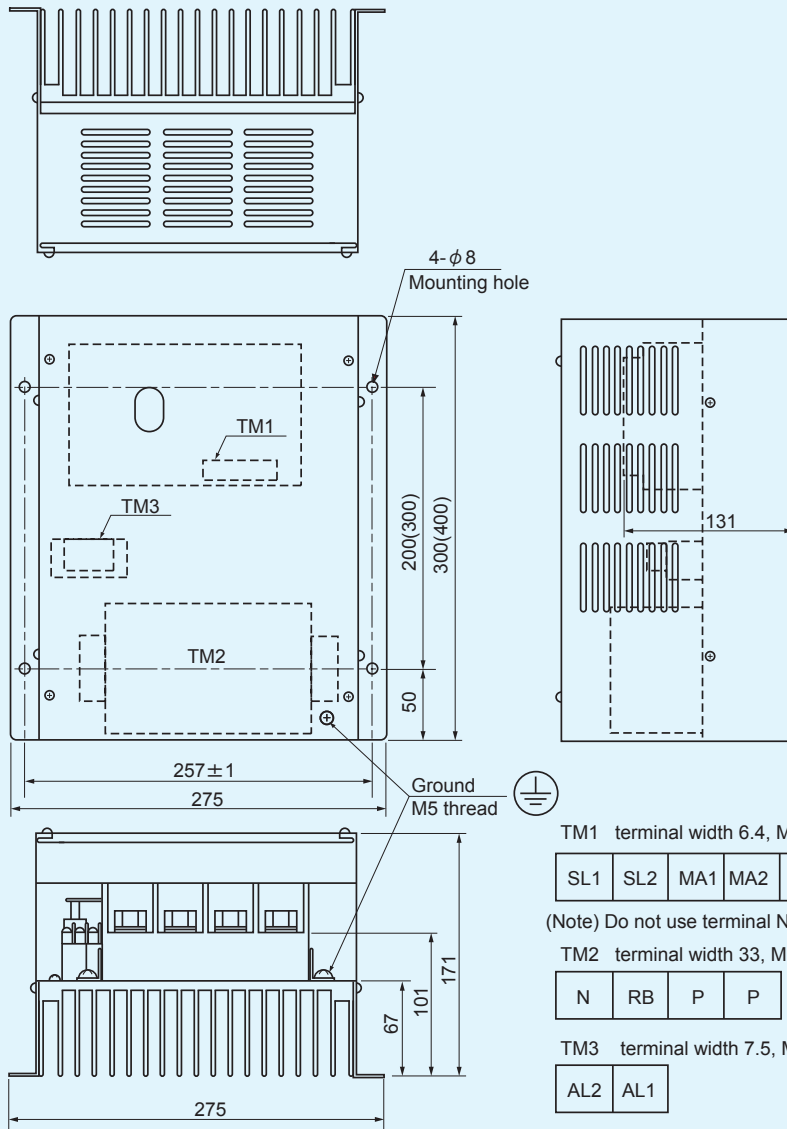

Braking Resistor

750W

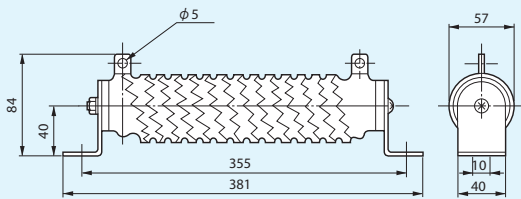

400W

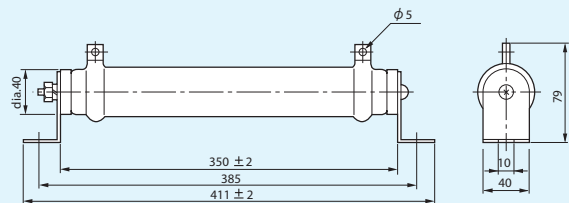

300W

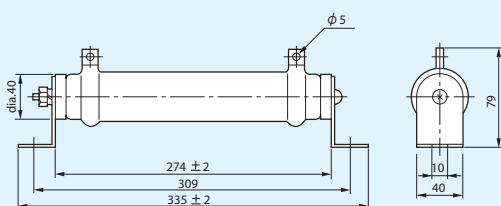

Note. When mounting the braking resistor, keep at least a 50mm clearance around the resistor.



External Options

[Installation]

When the inverter installation conditions are as follows, install an AC reactor on the primary side:

- (1) The capacity of the power transformer exceeds 500 kV.
- (2) The capacity of the power transformer exceeds 30 times the inverter capacity. AC current with a large peak value flows through the primary side of the inverter. This peak current increases in proportion to the capacity of the power transformer, leading to failure of the converter section in some cases. For prevention of such failure, an AC reactor must be installed. Especially in the case of a 400 V class power supply, care must be exercised because operation with a large capacity transformer is common.
- (3) Sudden change in supply voltage is expected.
(Example) When the phase advancing capacitor is changed over (charge/release) on the high voltage side.
- (4) Large-capacity thyristor Leonard equipment or other phase control equipment is installed on the same power supply system as the inverter.
- (5) The unbalance in the supply voltage is large
- (6) A phase advancing capacitor is installed in the same power supply system as the inverter.
- (7) Power factor improvement is necessary. Power factor can be improved by using AC or DC reactors on the inverter input side.
- (8) Harmonic suppression is necessary.

AC Reactor

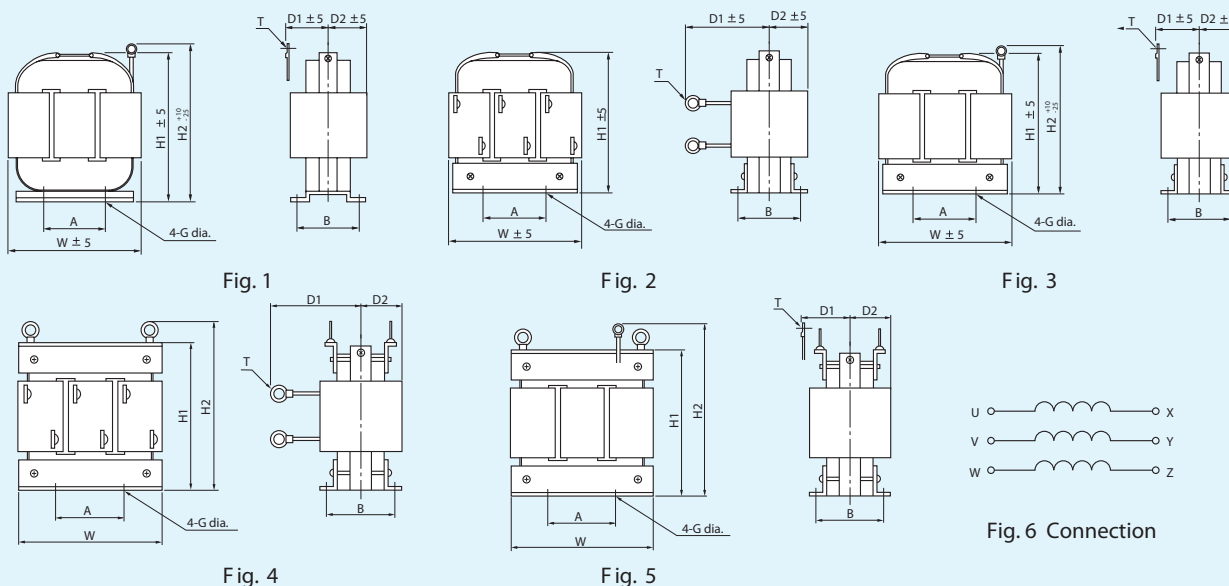

	Applicable rating (kW)	Specifications		Item No. Y220CA	W	D1	D2	H1	H2	A	B	G	T	Weight (kg)	Insulation	Figure
		Current (A)	L (mH)													
200V series	5.5	24	0.5	058	155	45	40	150	180	80	50	5	M5	3.9	F	1
	7.5	33	0.4	059	155	45	40	150	185	80	50	5	M6	4.4	F	
	11	47	0.3	060	155	50	45	150	185	80	50	5	M6	5.4	F	
	15	63	0.2	061	185	60	55	175	215	80	65	6	M6	7.2	F	
	22	92	0.15	063	185	53	48	175	220	80	65	6	M8	8.6	F	
	30	130	0.1	064	185	60	55	175	230	80	80	6	M10	10.5	F	2
	37	155	0.08	065	220	130	55	205	-	90	85	7	M10	13.0	F	
	45	190	0.07	066	220	150	65	205	240	90	100	7	M10	16.0	F	4
55	220	0.06	067	220	150	65	205	240	90	100	7	M12	19.0	F		

	Applicable rating (kW)	Specifications		Item No. Y220CA	W	D1	D2	H1	H2	A	B	G	T	Weight (kg)	Insulation	Figure
		Current (A)	L (mH)													
400V series	5.5	13	2.0	085	155	45	40	150	175	80	50	5	M4	4.2	B	1
	7.5	17	1.5	086	155	45	40	150	175	80	50	5	M5	4.5	B	
	11	25	1.0	087	155	50	45	150	180	80	55	5	M5	5.5	F	
	15	33	0.7	088	185	53	48	175	210	80	65	6	M6	6.3	F	
	22	48	0.5	090	185	60	55	175	215	80	80	6	M6	9.0	F	
	30	66	0.4	091	185	60	55	175	215	80	80	6	M6	11.0	F	3
	37	80	0.3	092	185	70	60	175	220	80	95	6	M8	12.0	F	
	45	100	0.25	093	220	60	55	205	250	90	85	7	M8	14.0	F	5
55	120	0.21	094	220	75	65	205	265	90	100	7	M10	17.0	F		

External Options

■ DC Reactor

- Remove the shorting bar from the reactor connection terminal of the inverter, and connect the DC reactor before use.
- Determine the place of installation so that the wiring distance from the inverter will be as short as possible.
- As with any harmonic suppression techniques, using the DC reactor in combination with AC reactor will improve overall noise suppression.
- When installing in a location with substantial vibration, use vibration absorbing mounts or a stabilizer to dampen vibration to the reactor.

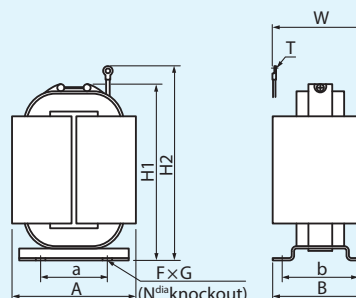

	Applicable rating (kW)	Specifications		Item No. Y220DA	Dimension (mm)									N	T	Weight (kg)
		Current (A)	L (mH)		A	a	B	b	H ₁	H ₂	W	F	G			
200V series	5.5	28.0	1.47	038	90	60	62	52	140	170	75	-	-	dia.5	M5	2.4
	7.5	38.0	1.11	039	100	80	95	80	140	170	95	5.5	7	-	M5	3.5
	11	55.0	0.79	040	100	80	95	80	140	175	100	5.5	7	-	M6	4.1
	15	75.0	0.59	041	125	105	105	80	142	175	120	5.5	7	-	M6	5.3
	22	110.0	0.40	043	140	120	110	90	150	205	135	6.5	9	-	M8	7.5
	30	150.0	0.30	044	150	120	120	100	150	215	145	6.5	9	-	M8	9.4
	37	190.0	0.25	045	160	130	135	115	170	240	170	6.5	9	-	M10	12.3
	45	230.0	0.20	046	170	130	135	115	173	255	170	6.5	9	-	M10	13.3
	55	280.0	0.17	047	180	150	145	120	190	270	170	-	-	dia.8	M12	15.9

	Applicable rating (kW)	Specifications		Item No. Y220CA	Dimension (mm)									N	T	Weight (kg)
		Current (A)	L (mH)		A	a	B	b	H ₁	H ₂	W	F	G			
400V series	5.5	14.0	5.87	008	90	60	62	52	140	165	75	-	-	dia.5	M5	1.5
	7.5	19.0	4.46	009	100	80	95	80	140	165	95	5.5	7	-	M5	3.5
	11	27.5	3.13	010	100	80	95	80	140	165	100	5.5	7	-	M5	3.9
	15	37.5	2.35	011	125	105	105	80	142	175	120	5.5	7	-	M6	5.3
	22	55.0	1.60	013	140	120	110	90	150	185	135	6.5	9	-	M6	7.3
	30	75.0	1.22	014	150	120	120	100	150	205	145	6.5	9	-	M8	9.2
	37	92.5	0.99	015	160	130	135	115	170	225	170	6.5	9	-	M8	12.0
	45	113.0	0.81	016	170	130	135	115	170	230	170	6.5	9	-	M8	13.0
	55	138.0	0.66	017	180	150	145	120	170	255	170	-	-	dia.8	M8	15.3

External Options

Frequency setting unit : VR-07 [1kΩ, 2W]
 Model No. VR07
 Unit : mm

Bakelite plate (0.8t)
 Mounting panel
 Control: 3 k Ω; 2 W
 Panel cut

% Speed meter: DCF-12NB [10V F.S.]
 0 - 100% ; 50divisions (X525AA048)
 Unit : mm

M4 (M5) Terminal screw thread
 M4 mounting bolt
 Panel cut
 4-dia.5 hole

AC Ammeter: ACF-12NB
 The CT directly detects the current of the secondary side of the inverter.
 Unit : mm

ACF-12NB
 COMA-15
 COM-15-26

Table of combination of AC ammeter (ACF-12NB) and current transformer

Motor capacity (kW)	200V class					400V class				
	Part No.	Meter		CT Type	Number of primary through holes	Part No.	Meter		CT Type	Number of primary through holes
		Rated current [A]	Max. scale [A]				Rated current [A]	Max. scale [A]		
5.5	X525AA042	5	50	COM-15-26 50/5A	3	X525AA082	5	20	COMA-15 20/5A	-
7.5	X525AA042	5	50	COM-15-26 50/5A	3	X525AA083	5	30	COMA-15 30/5A	-
11	X525AA043	5	75	COM-15-26 75/5A	2	X525AA042	5	50	COM-15-26 50/5A	3
15	X525AA116	5	100	COM-15-30 100/5A	2	X525AA042	5	50	COM-15-26 50/5A	3
22	X525AA044	5	150	COM-15-26 150/5A	1	X525AA043	5	75	COM-15-26 75/5A	2
30	X525AA045	5	200	COM-15-30 200/5A	1	X525AA116	5	100	COM-15-30 100/5A	2
37	X525AA046	5	250	COM-15-30 250/5A	1	X525AA044	5	150	COM-15-26 150/5A	1
45	X525AA047	5	300	COM-15-30 300/5A	1	X525AA044	5	150	COM-15-26 150/5A	1
55	X525AA121	5	400	COM-15-30 400/5A	1	X525AA045	5	200	COM-15-30 200/5A	1

Construction of current transformer (CT) COMA-15 type: Totally molded current transformer with primary winding
 COM-15-26 type: Totally molded current transformer, throughholes type
 COM-15-30 type: Totally molded current transformer, throughholes type
 Install the current transformer (CT) on the output side of the inverter.

External Options

Dimensional Drawing of LC Filter

Fig.1

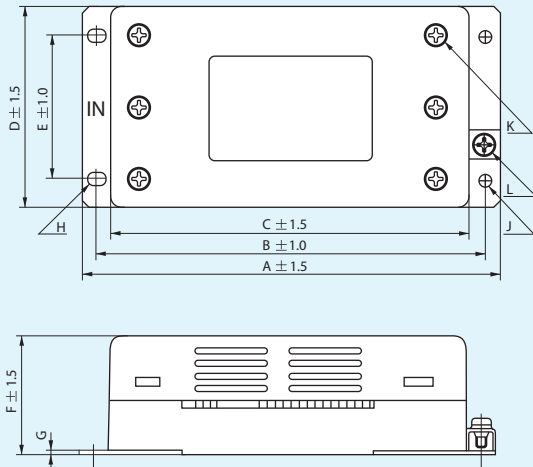

Model	Type	A	B	C	D	E	F	G	H	J	K	L
X480AC291	NF3030A-VZ	145	135	125	70	50	42	1.0	4.5×6	dia. 4.5	M4	
X480AC292	NF3040A-VZ	179	167	155	90	70	54	1.6			M5	
X480AC296	NF3010C-VZ	128	118	108	63	43	42	1.0			M4	
X480AC297	NF3020C-VZ										M4	
X480AC298	NF3030C-VZ	145	135	125	70	50					M5	
X480AC299	NF3040C-VZ	179	167	155	90	54	54	1.6				

Fig.2

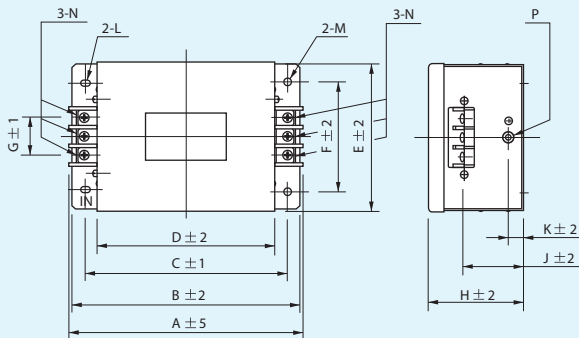

Model	Type	A	B	C	D	E	F	G	H	J	K	L	M	N	P
X480AC293	NF3080A-RQ2	217	200	185	170	120	90	44	115	85	20	5.5×7	dia.5.5	M6	M4
X480AC294	NF3150A-RQ2	314	300	280	260	200	170	57	130	90	35	6.5×8	dia.6.5	M8	M6
X480AC300	NF3080C-RQ2	217	200	185	170	120	90	44	115	85	20	5.5×7	dia.5.5	M6	M4
X480AC301	NF3100C-RQ2	254	230	215	200	150	120	57	115	80	30	6.5×8	dia.6.5	M8	M6
X480AC302	NF3150C-RQ2	314	300	280	260	200	170	57	130	90	35	6.5×8	dia.6.5	M8	M6

Fig.3

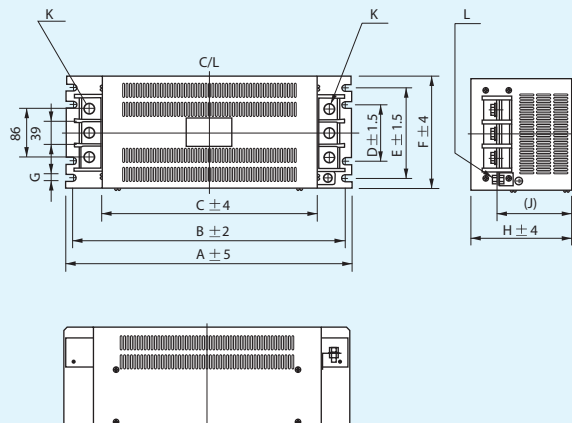

Model	Type	A	B	C	D	E	F	G	H	J	K	L
X480AC295	NF3200A-RQ2	450	430	338	100	190	230	7	180	(133)	M10	M8
X480AC308	NF3250A-RQ2											

(Connection method)

- (1) Install the filter between the power supply and inverter input terminal. Make the connection wire between the inverter and filter as short as possible.
- (2) Use thick short grounding wire as much as possible. Connect the grounding wire correctly.
- (3) Separate the input/output lines of the filter.
- (4) The filter cannot be used on the inverter output (motor) side.

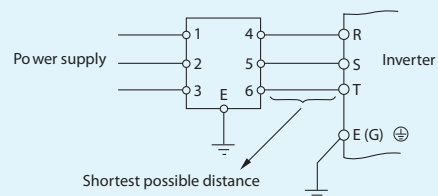

External Options

Input/Output side filter

Noise filter

Install input/output side filters in order to lower the noise level from the inverter and protect peripheral equipment from the adverse effects of noise. The standard input-side filters are the LC-type noise filter, zero-phase reactor, and capacitive (XY) filter, while the standard output-side filter is the zero-phase reactor. When filters that conform to the noise control regulations is desired, contact our Sales Division.

LC filter : Substantially attenuates noise from the inverter.

Zero-phase reactor : Lowers the level of noise transmitted from the power supply side or output side

Capacitive filter : Lowers the level of noise in the AM radio frequency band.

1. Zero-phase reactor: RC9129 (X480AC192)

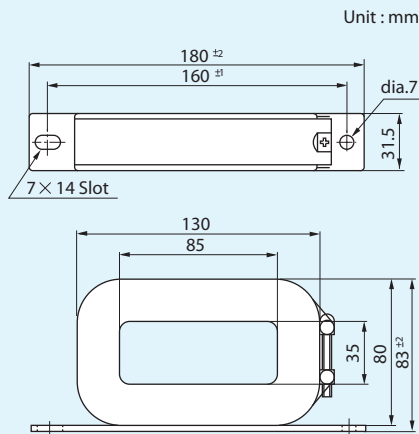

[Method of connection]

- (1) It can be used on both inverter input (power supply) side and output (motor) side.
- (2) Wind the three wires of respective phases on the input or output side more than three times (4 turns) in the same direction. When winding wires more than three times (4 turns) is impossible because the wire is too thick, install two or more zerophase reactors side by side to reduce the number of turns.
- (3) Make the gap between the cable and core as small as possible.

Wire size (Note)	14 mm ² or less	14–30mm ²	22mm ² –
Winding turns	3 times (4T)	Once (2T)	Through (1T)
Qty	1 pc	2 pcs	4 pcs
Winding method			

Note: The size of wire differs according to the kind of wire (flexibly).

2. LC filter (High attenuation filter)

Contact our agency for the general-purpose filter, output-side LC filter, and filters (installed on the output side) that conform to various standards (VCCI, FCC, and VDE).

List of LC filters

Applicable motor (kW)	Model	200V input side	Fig.
		Type	
5.5	X480AC291	NF3030A-VZ	Fig.1
7.5	X480AC292	NF3040A-VZ	
11	X480AC293	NF3080A-RQ2	Fig.2
15			
22	X480AC294	NF3150A-RQ2	Fig.3
-37	X480AC295	NF3200A-RQ2	
-55	X480AC308	NF3250A-RQ2	

Note: Ground the LC filter with its own ground connection

Applicable motor (kW)	Model	400V input side	Fig.
		Type	
5.5	X480AC297	NF3020C-VZ	Fig.1
7.5			
11	X480AC298	NF3030C-VZ	
15	X480AC299	NF3040C-VZ	
22	X480AC300	NF3080C-RQ2	Fig.2
30			
37	X480AC301	NF3100C-RQ2	
-55	X480AC303	NF3150C-RQ2	

External Options

3. Capacitive Filter (XY Filter)

[Applicable type]

Common to all ratings; 200/400 V common 3XYHB-105104 X480AC185

[Method of connection]

- (1) Connect it directly to the inverter input (power supply) terminal.
Make the connection line as short as possible.
- (2) Ensure correct grounding. (Grounding resistance: 100 Ω or less)
- (3) Do not use on the inverter output (motor) side.

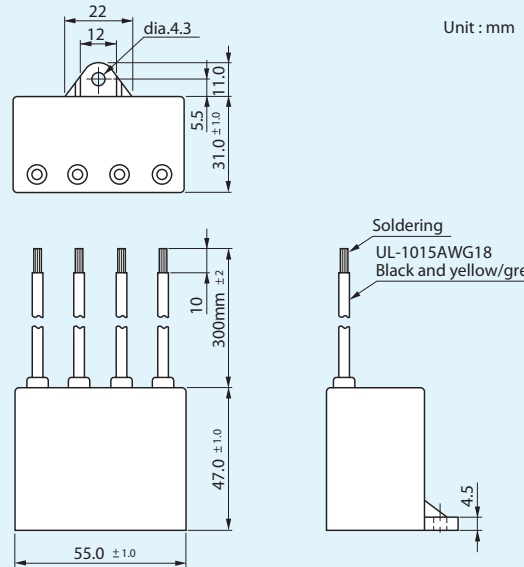
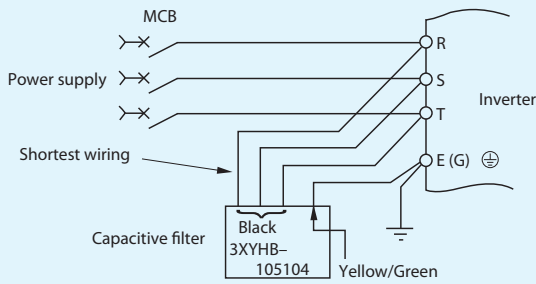

Application for Noise Filter

When AM Radio Picks Up Noise

Take possible measures among the following in the order of 1 to 12. Each measure will improve noise reduction.

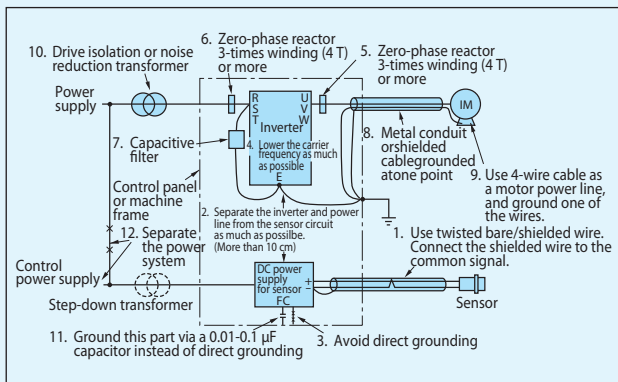

6. Install an LC filter on the input side of the inverter. (Type: FS)
7. Install a capacitive filter on the input side of the inverter. (Type: 3XYHB-105104)
8. Use a metal conduit or shielded cable for power supply wiring.
9. Use 4-wire cable as a motor power line, and ground one of the wires.
10. Install a drive isolation or noise reduction transformer for the inverter power supply.
11. Ground the power supply for the sensor via a 0.01-0.1 μF (630V).
12. Separate the inverter power supply from the sensor power supply system.

Corrective measures

1. Use twisted pair/shielded wire as a sensor signal line, and connect the shielded wire to common.
2. Separate the inverter and power line from the sensor circuit as much as possible. (More than 10 cm desirable)
3. Remove the grounding wire when the power supply for the sensor is grounded.
4. Lower the carrier frequency as much as possible. Up to approx. 10 kHz when low-noise operation is necessary.
5. Install a zero-phase reactor on the output side of the inverter. (Type: RC5078, RC9129)

Connection of zero-phase reactors and a capacitive filter

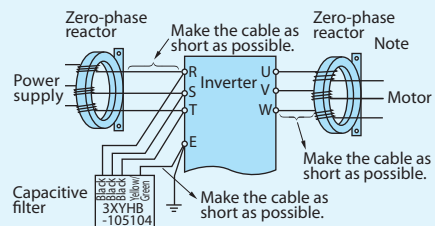

Note: Turn wires the same number of times for all phases of the zero-phase reactor. 3 times (4 T) or more. Increase the number of zero-phase reactors when the cable is too thick to wind correctly.

External Options

■ When AM Radio Picks Up Noise

1. When noise level is high

Take possible measures among the following in the order of 1 to 7. Each measure will improve noise reduction.

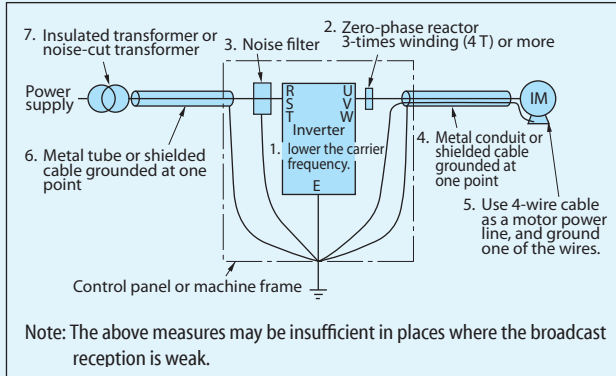

■ Corrective measures

1. Lower the carrier frequency as much as possible. Up to approx. 10 kHz when low-noise operation is necessary.
2. Install a zero-phase reactor on the output side of the inverter. (Type: RC9129)
3. Install an Noise filter on the input side of the inverter. (NF3 □□□□ -VZ)
4. Connect the inverter and motor with a metal conduit or shielded cable.
5. Use 4-wire cable as a motor power line, and ground one of the wires.
6. Connect the inverter and power with a metal conduit or shielded cable.
7. Install a drive isolation or noise reduction transformer for the power supply. □□□□ differs according to the inverter capacity and voltage.

■ Connection of a zero-phase reactor and a noise filter

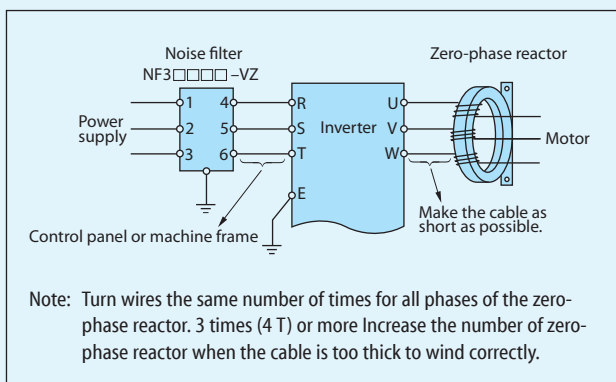

2. When noise level is low

Take possible measures among the following in the order of 1 to 6. Each measure will improve noise reduction.

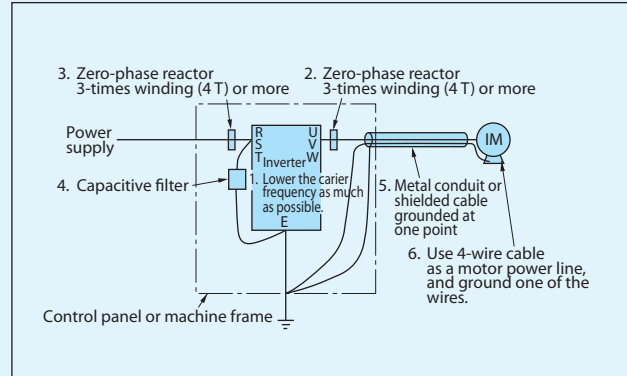

■ Corrective measures

1. Lower the carrier frequency as much as possible. Up to approx. 10 kHz when low-noise operation is necessary.
2. Install a zero-phase reactor on the output side of the inverter. (Type: RC9129)
3. Install a zero-phase reactor on the input side the inverter. (Type: RC9129)
4. Install a capacitive filter on the input side of the inverter. (Type: 3XYHB-105104)
5. Connect the inverter and motor with a metal conduit or shielded cable.
6. Use 4-wire cable as a motor power line, and ground one of the wires.

■ Connection of zero-phase reactors and a capacitive filter

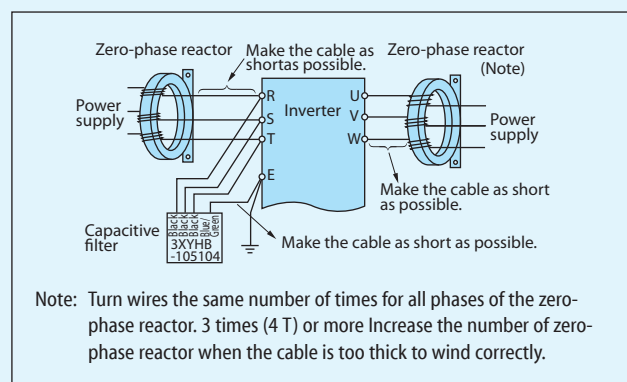

Notes to Inverter Users

■ Precautions for Application of Inverter

● Power supply

1. When the inverter is connected directly to a large-capacity power supply (especially in a 400 V line), excessively large peak will flow in, breaking the inverter unit. In such a case, install an AC reactor (option) on the input side of the inverter unit.
2. Install an AC reactor in the following cases as well.
 - 1) There is a possibility of surge voltage generated in the power supply system: When surge energy flows into the inverter, OV tripping may result.
 - 2) When a large-capacity thyristor Leonard or other phase control units are installed
3. When the inverter is operated by a private power generator, secure a sufficiently large generation capacity for the inverter kVA in consideration of the influence of higher harmonic current on the generator.

● Installation

1. Do not install the inverter in places with poor environmental conditions subjected to dust, oil mist, corrosive gas, or inflammable gas.
2. In places where there is suspended matter in the air, install the inverter inside a "closed-type" panel to prevent entry of suspended matter. Determine the cooling method and dimensions of the panel so that the ambient temperature around the inverter will be lower than the allowable temperature.
3. Vertically install the inverter on a wall. Do not install it on wood or other inflammable products.

● Handling

1. Do not connect the output terminal UVW of the inverter to the power supply; otherwise the inverter will be broken. Carefully check the wiring for correct arrangement before turning on the power.
2. It takes some time for the internal capacitors to discharge completely after the power is turned off. Check that the charge lamp on the printed circuit board is OFF before inspection.

● Operation

1. Do not start and stop the inverter frequently by means of an electromagnetic contactor (MC) installed on the input side of the inverter; otherwise failure of the inverter will result.
2. When more than one motor is operated by one inverter, select the inverter capacity so that 1.1 times the total rated current of the motors will not exceed the rated output current of the inverter.
3. When an error occurs, the protective function is activated and the inverter trips and stops operation. In that case, motors will not stop immediately. When emergency stop is desired, use mechanical brakes as well.
4. The acceleration time of the motor is subject to the inertial moment of the motor and load, motor torque, and load torque.
 - 1) When the acceleration time setting is too short, the stall prevention function is activated, and the setting time is elongated automatically. For stable acceleration and deceleration, set longer time so that the stall prevention function will not be activated.
 - 2) When the deceleration time is too short, the stall prevention function is activated or OV tripping will result. Set longer deceleration time or install a braking unit/braking resistor.

■ When Operating 400 V Class Standard Motor

When the inverter is used to drive a standard motor (general-purpose motor), a high carrier frequency type inverter (e.g. IGBT) requiring high input voltage (more than 400 V) is necessary. When the wiring distance is long, the withstand voltage of the motor must be taken into consideration. Contact us in such cases.

■ Continuous Operation Torque Characteristics

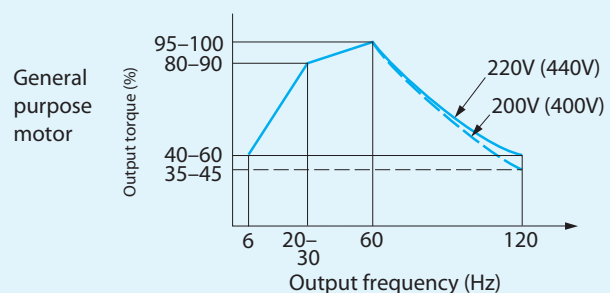
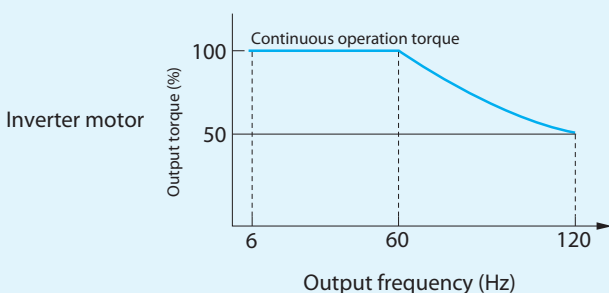

Notes to Inverter Users

■ Motor Temperature Rise

When a general-purpose motor is used in variable-speed operation with an inverter, the temperature rise of the motor will be slightly greater than in cases where commercial power is used. The causes are shown below:

Influence of output waveform	Unlike commercial power, the output waveform of an inverter is not a perfect sine wave, and contains higher harmonics. Therefore, the motor loss increases and the temperature is slightly higher.
Reduction in the motor cooling effect	Motors are cooled by the fan on the motor itself. When the motor speed is reduced by an inverter, the cooling effect will decrease.

Therefore, lower the load torque or use an inverter motor to control temperature rise when the frequency is below the frequency of commercial power.

The inverter described in this brochure is used for variable-speed operation of 3-phase induction motors for general industry use.



- ▼The inverter described in this brochure is not designed and manufactured for use in equipment or a system used under the following conditions that will directly lead to death or injury : atomic energy control, aerospace equipment, traffic equipment, medical instrument and all kinds of safety devices. When our products are applied to the above equipment or system, be sure to consult us.
- ▼Our products are manufactured under stringent quality control. However, install a safety device on the equipment side in order to prevent serious accidents or loss when our products are applied to equipment that may cause serious accidents or loss due to failure or malfunction.
- ▼Do not use the inverter for any load other than 3-phase induction motors.
- ▼When an explosion-proof motor is selected, pay attention to the installation environment, because the inverter is not of an explosion-proof type.
- ▼Carefully read the "Operation Manual" before use for correct operation.
Read the manual carefully also for long-term storage.
- ▼Electrical work is necessary for installation of the inverter. Leave the electric work to specialists.

The cautions to special motor application

<Pole change motor>

Since the pole change motor differs from ampere rating, the maximum current of the motor is checked and an inverter is selected.

Please be sure to perform the change of the number of poles, after stopping the motor.

If it carries out, over voltage or over current protection will operate, and the motor will serve as a free run.

<Motor with the brake>

The power supply for the brake is certainly connected to the primary side of an inverter.

Please shut down an inverter output at the time of the brake operation (at the time of the motor stop).

In the kind of brake, the sound of lining may come out in a low-speed.

<Single-phase motor>

The single-phase motor does not fit an inverter drive.

There is a possibility of current flowing and destroying a capacitor and the thing of phase-splitting starting and rebounding starting is internal centrifugally.

In order that the power switch may not operate, there is a possibility of damaging a starting coil by fire.

Warranty

■ Warranty Policy on Inverter

Warranty period	The warranty shall be 18 months from date of shipment or 12 months after initial operation, whichever is shorter.
Warranty condition	In the event that any problem or damage to the Product arises during the "Warranty Period" from defects in the Product whenever the Product is properly installed and combined with the Buyer's equipment or machines maintained as specified in the maintenance manual, and properly operated under the conditions described in the catalog or as otherwise agreed upon in writing between the Seller and the Buyer or its customers; the Seller will provide, at its sole discretion, appropriate repair or replacement of the Product without charge at a designated facility, except as stipulated in the "Warranty Exclusions" as described below. However, if the Product is installed or integrated into the Buyer's equipment or machines, the Seller shall not reimburse the cost of: removal or re-installation of the Product or other incidental costs related thereto, any lost opportunity, any profit loss or other incidental or consequential losses or damages incurred by the Buyer or its customers.
Warranty exclusion	Notwithstanding the above warranty, the warranty as set forth herein shall not apply to any problem or damage to the Product that is caused by: <ol style="list-style-type: none"> 1. Installation, connection, combination or integration of the Product in or to the other equipment or machine that rendered by any person or entity other than the Seller; 2. Insufficient maintenance or improper operation by the Buyer or its customers such that the Product is not maintained in accordance with the maintenance manual provided or designated by the Seller; 3. Improper use or operation of the Product by the Buyer or its customers that is not informed to the Seller, including, without limitation, the Buyer's or its customers' operation of the Product not in conformity with the specifications; 4. Any problem or damage on any equipment or machine to which the Product is installed, connected or combined or any specifications particular to the Buyer or its customers; 5. Any changes, modifications, improvements or alterations to the Product or those functions that are rendered on the Product by any person or entity other than the Seller; 6. Any parts in the Product that are supplied or designated by the Buyer or its customers; 7. Earthquake, fire, flood, salt air, gas, lightning, acts of God or any other reasons beyond the control of the Seller; 8. Normal wear and tear, or deterioration of the Product's parts, such as the cooling fan bearings; 9. Any other troubles, problems or damage to the Product that are not attributable to the Seller.
Others	The Seller will not be responsible for the installation and removal of the inverter. Any inverter transportation cost shall be borne by both Seller and Buyer.

■ Warranty Policy on Repaired and Returned Products

Warranty period	The warranty shall be 6 months from date of repair and shipment.
Warranty condition	Warranty on repaired Product will apply only on the replacement parts used in the repair done or authorized by the Seller. All other aspects conform to the Warranty Conditions described in item 1.
Warranty exclusion	Please refer to Warranty Exclusions described in item 1.
Others	Please refer to Others described in item 1.