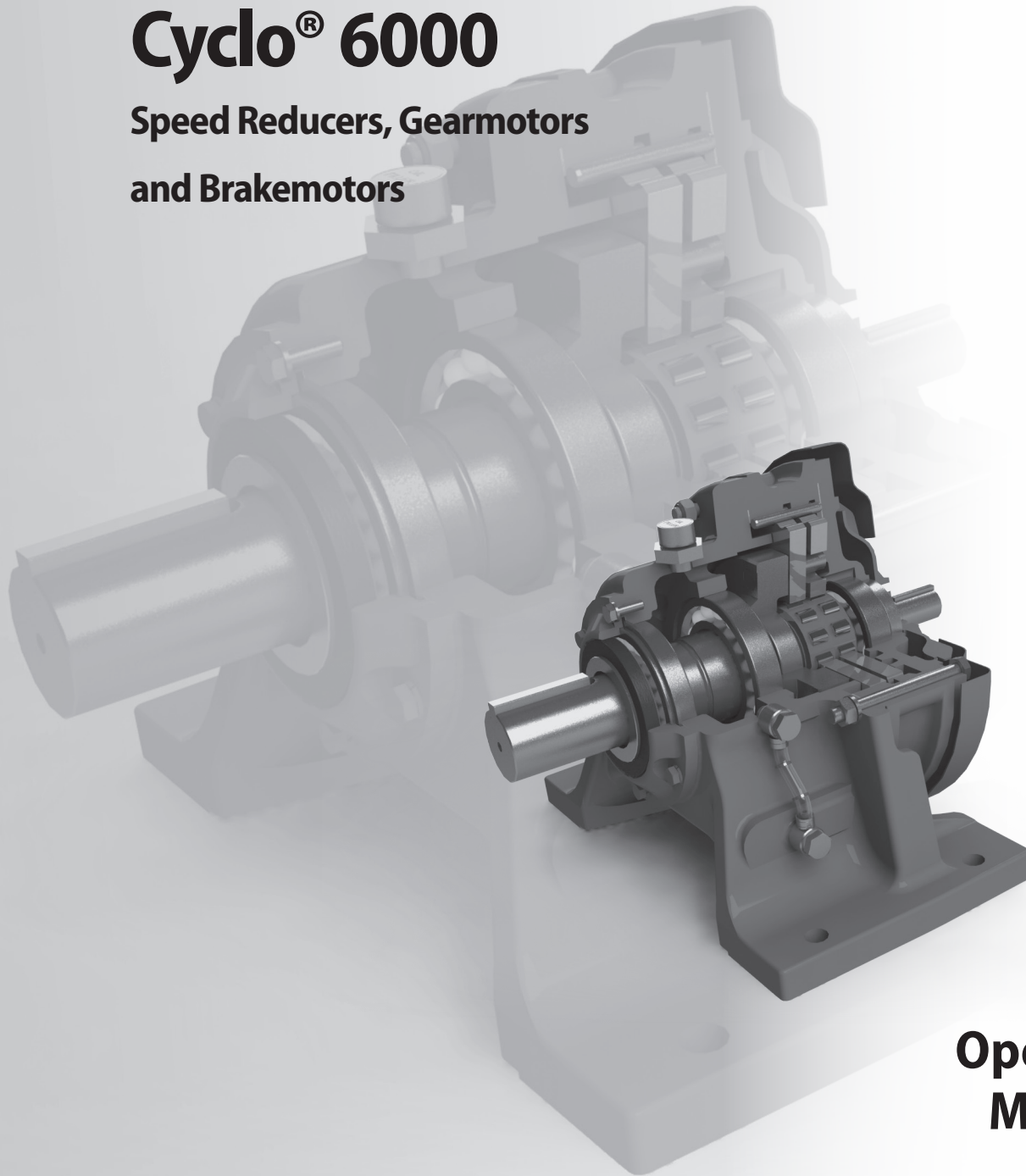


# Cyclo<sup>®</sup> 6000

Speed Reducers, Gearmotors  
and Brakemotors



## Operation and Maintenance Manual

# TABLE OF CONTENTS

---

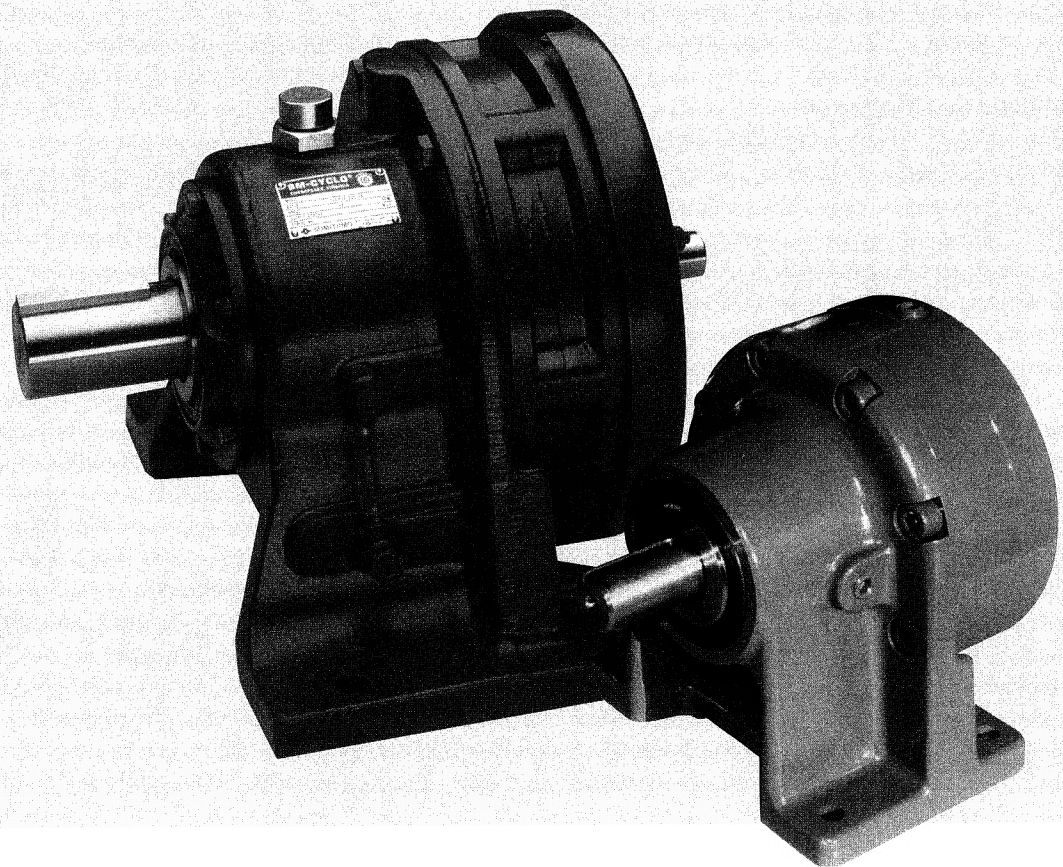
	Page
<b>SM-CYCLO SPEED REDUCERS</b>	
Mounting .....	A-2
General Construction .....	A-3
Lubrication .....	A-5
Bearings, Oil Seals, Gaskets .....	A-11
Disassembly, Assembly .....	A-14
Daily Inspection, Ordering Replacement Units or Parts, Storage .....	A-16
Troubleshooting and Repair .....	A-17
<b>SM-CYCLO GEARMOTORS</b>	
Mounting .....	B-2
General Construction .....	B-3
Lubrication .....	B-5
Bearings, Oil Seals, Gaskets .....	B-11
Electric Motor .....	B-14
General Construction of Motor .....	B-15
Motor Inspection and Start-up .....	B-16
Motor Bearings and Oil Seals .....	B-17
Gearmotor Disassembly, Assembly .....	B-20
Troubleshooting and Repair .....	B-22
Maintenance, Inspection, Ordering Replacement Units or Parts, Storage .....	B-24
<b>SM-CYCLO BRAKEMOTORS</b>	
General Construction .....	C-3
FB Models Standard Specifications .....	C-4
FB Models Construction, Operation & Maintenance .....	C-5
FB Models Wiring Diagrams .....	C-10
FB Models Troubleshooting .....	C-12
Model CMB-20 .....	C-13
<b>APPENDIX</b>	
Grease Quantities for Units Having Optional Grease Lubrication.....	D-2
Food-Grade Lubricants .....	D-3

## WARNINGS

- Consult factory if SM-Cyclo speed reducers are driven by D.C. motors, variable frequency A.C. drives, or speeds other than standard catalog input speeds.
- Be sure to install and operate SM-Cyclo speed reducers, gearmotors and brakemotors in compliance with applicable local and national safety codes. Appropriate guards for rotating shafts should be used and are available from the factory.
- When using SM-Cyclo speed reducers, gearmotors or brakemotors in a system for human transport, install a secondary safety device in order to minimize the risk of accidents that may result in personal injury, death or equipment damage.

---

# SM-CYCLO<sup>®</sup> SPEED REDUCERS



# SECTION A CONTENTS

Mounting . . . . .	A-2	Allowable Oil Viscosity . . . . .	A-9
General Construction . . . . .	A-3, 4	Oil Change . . . . .	A-9
Lubrication . . . . .	A-5~10	Forced Lubrication . . . . .	A-9
Grease Units . . . . .	A-7, 8	Oil Level Dimensions . . . . .	A-10
Designated Greases . . . . .	A-7	Bearings, Oil Seals & Gaskets . . . . .	A-11~13
Grease Replenishment & Change . . . . .	A-7	Dissassembly, Assembly . . . . .	A-14, 15
Quantities of Grease . . . . .	A-7, 8	Daily Inspection . . . . .	A-16
Oil Units . . . . .	A-8 ~ 10	Ordering Correct Replacement Units & Parts . . . . .	A-16
Oil Fill Procedure, Oil Gauge . . . . .	A-8	Storage & Operation After Storage . . . . .	A-16
Standard Oils . . . . .	A-8	Trouble Shooting . . . . .	A-17
Oil Quantities . . . . .	A-9	Notes . . . . .	A-18

## Mounting

### 1. Mounting on Exact Planes

The Horizontal Type oil-lubricated units must be mounted on horizontal surfaces. Where they are mounted on inclined surfaces, some modifications may be necessary. Specify mounting plane inclination at time of ordering.

### 2. Accurate Alignment

Where the reducer is connected to the motor and the driven machine through couplings, align the shafts accurately. Where the reducer is connected through V pulleys or sprockets, insure that the belts or chains are neither too tight nor too slack.

### 3. Overhung Load Positions

Overhung loads should be located as close to the bearing as possible. (See the SM-CYCLO® 6000 Series Catalog page E-8.)

### 4. Foundations

Foundations must be rugged enough to withstand shock and stress applied from the load side through the reducer.

### 5. Secure Housing

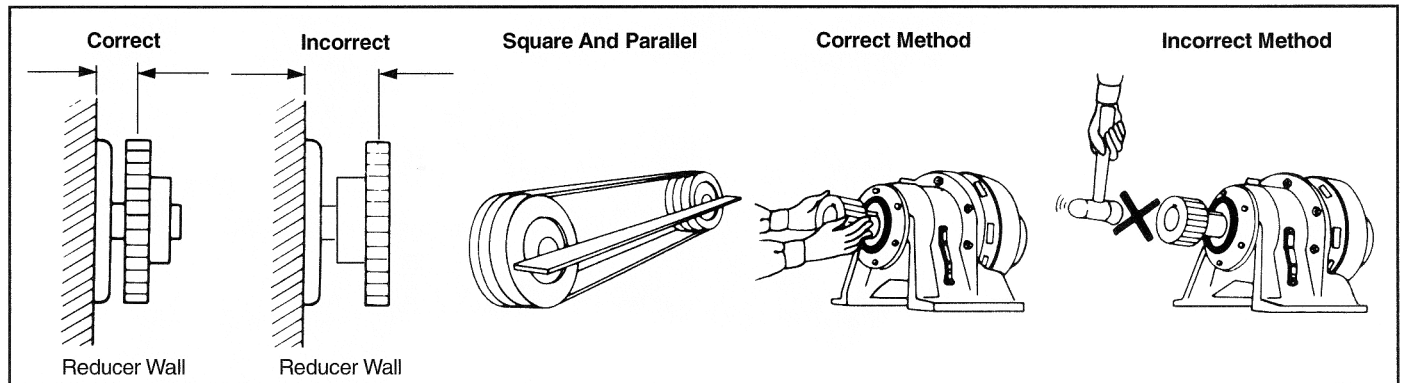
Where the reduction units are operated under conditions of vibration and/or frequent starts and stops, it is recommended to secure them on their mounting surfaces by inserting dowel pins into the knock-holes provided on the foot of the casing. This will insure that bending or shearing forces are reduced on the mounting bolts. Pins must be securely inserted, particularly when the units are to be operated under conditions of severe recurrent peak loads.

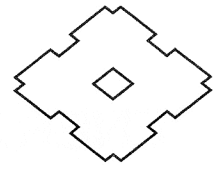
### 6. Mounting Accessibility

The reduction units must be mounted in locations with easy accessibility for lubrication maintenance purposes.

### 7. Ventilation

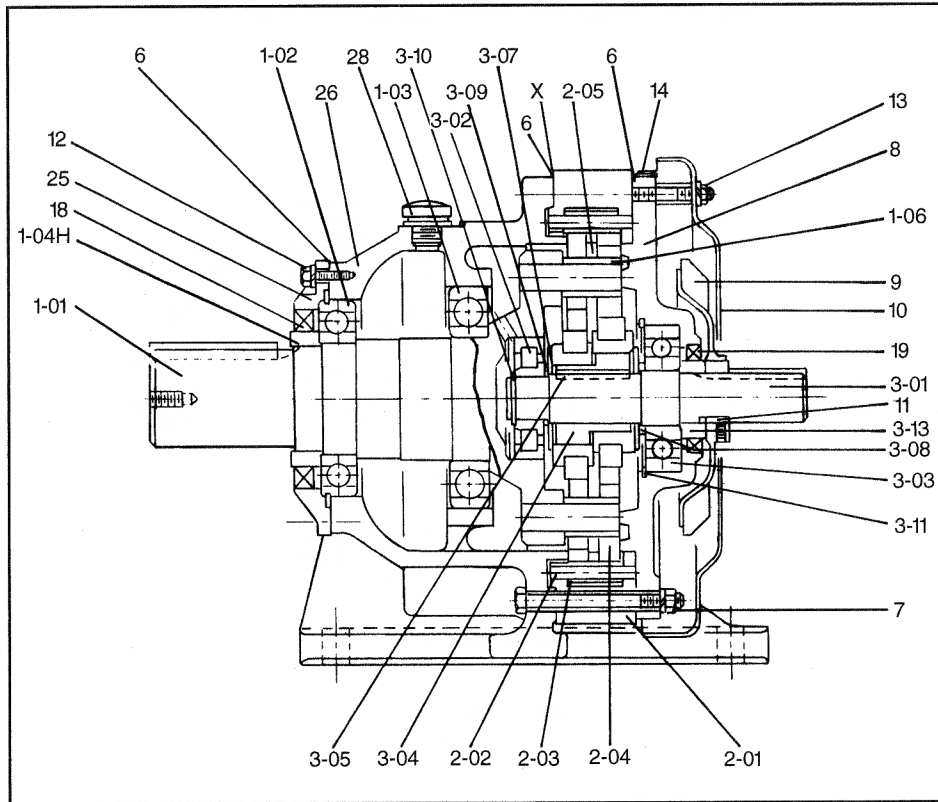
When the SM-CYCLO® Speed Reducer is mounted in a separate enclosure, be sure that adequate ventilation is provided.



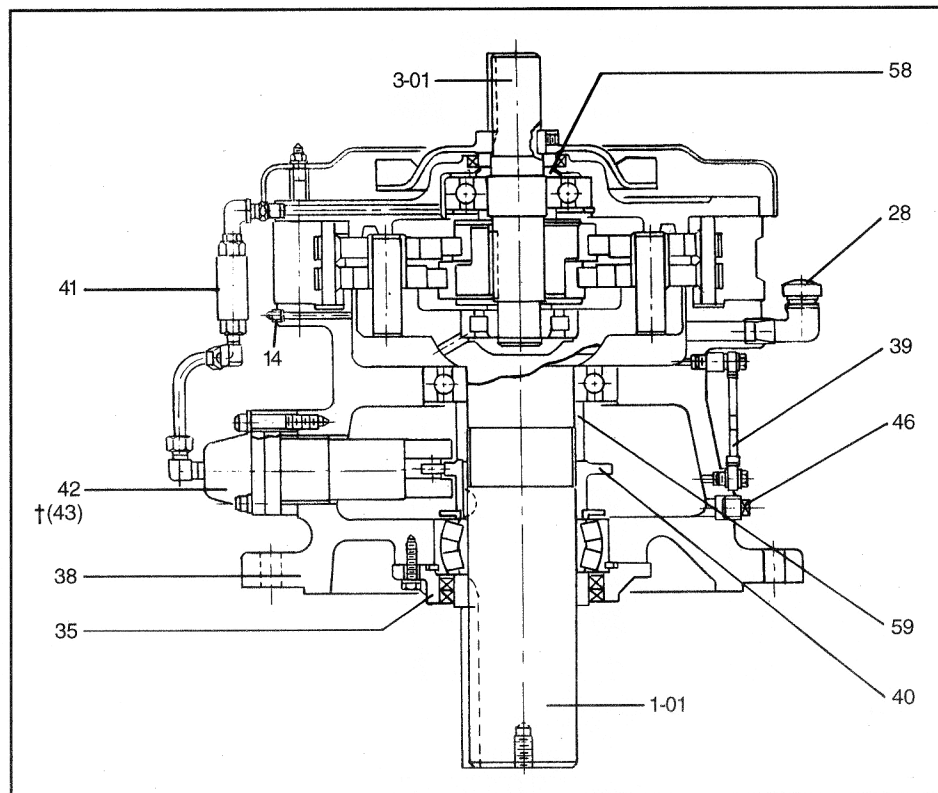


# GENERAL CONSTRUCTION

**Fig. A-1 Speed Reducer – Horizontal Foot Mount, Single Reduction**



**Fig. A-2 Speed Reducer – Vertical Base Mount, Single Reduction**



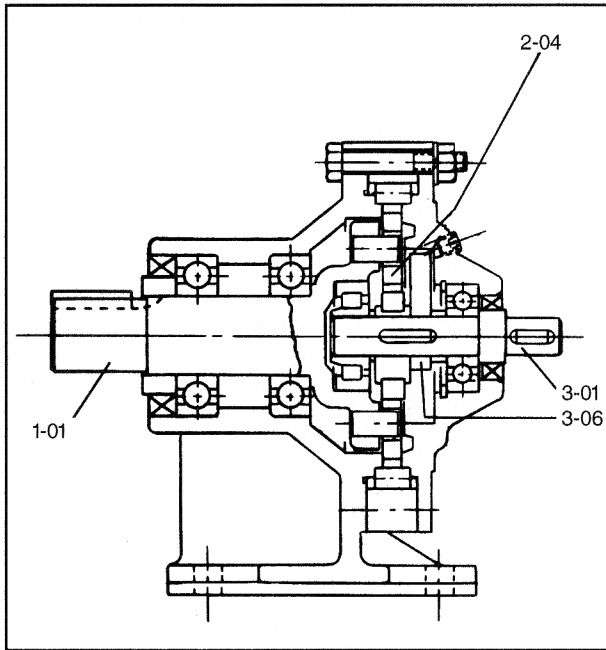
**Table A-1. Speed Reducer Main Parts**

Part No.	Part Name
1-01	Slow Speed Shaft w/pins
1-02	Bearing A
1-03	Bearing B
1-04H	Oil Seal Collar—Horizontal
1-06	Slow Speed Shaft Rollers
2-01	Ring Gear Housing
2-02	Ring Gear Pins
2-03	Ring Gear Rollers
2-04	Cyclo Disc
2-05	Spacer Ring
3-01	High Speed Shaft
3-02	Bearing C
3-03	Bearing D
3-04	Eccentric Bearing Assembly
3-05	Eccentric Key
**3-06	Balance Weight
3-07	Spacer
3-08	Spacer
3-09	Spacer
3-10	Retaining Ring
3-11	Retaining Ring
3-13	Collar
† 5-01	Intermediate Shaft w/Pins
† 5-02	Bearing F
† 5-03	Bearing G
† 5-04	Eccentric Bearing Assembly
6	Gasket Set
7	Casing Nuts & Bolts
8	High Speed End Shield
9	Cooling Fan & Set Screw
10	Fan Cover
11	Fan Key
12	Bolts For SS Oil Seal Housing
13	Bolts, Spacers For Fan Cover
14	Plug
† 15	Grease Nipple
18	Slow Speed Output Oil Seal
19	High Speed Input Oil Seal
25	Horizontal Oil Seal Housing
26	Horizontal Case
28	Oil Fill Plug
29	Oil Gauge—Horizontal Unit
35	Vertical Oil Seal Housing
38	Vertical Case (Integral V Type)
39	Oil Gauge—Vertical Unit
40	Cam
41	Piping Set & Oil Signal
42	Plunger Pump
43	Positive Displacement Pump
46	Drain Plug
† 55	Intermediate Cover
† 57	Eye Bolt
*58	Oil Slinger
*59	Spacer

Note: For details of oil seals, bearings or gaskets, refer to A-11 ~ 13.  
 †Refer to Table A-16 on Pg. A-9 for units which require a positive displacement pump.  
 \*Pt. No. 58 — frame sizes 6195-6275 only; Pt. No. 59 — frame sizes 6205-6275 only.  
 \*\*See Fig. A-3, Page A-4; † See Fig. A-4, Page A-4.

# GENERAL CONSTRUCTION

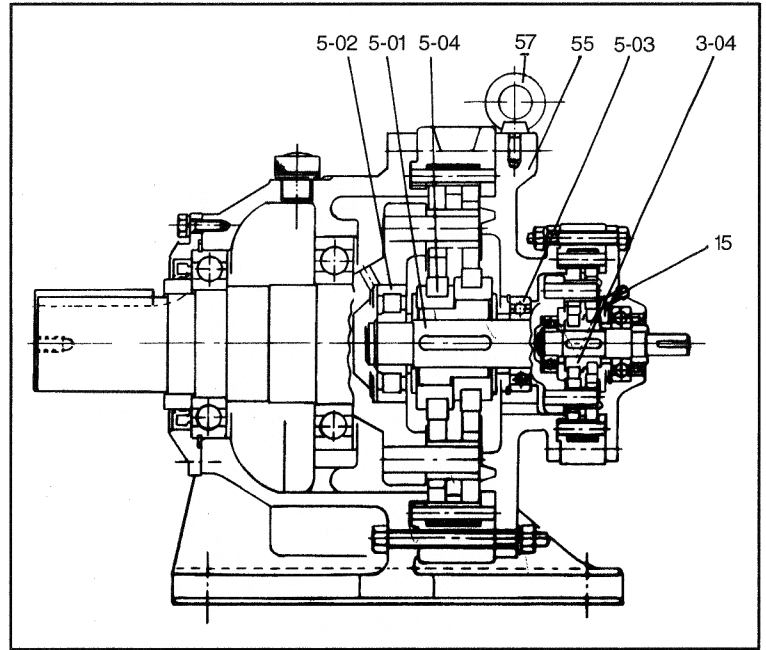
**Fig. A-3 Speed Reducer/Single Disc Type (Frame Size 6060-6095)**



**Speed Reducer — Single Disc**

SM-CYCLO® single reduction, Models No. 6060-6095, employ the use of a single planetary gear (Cycloid Disc) and a balance weight.

**Fig. A-4 Speed Reducer/Double Reduction**



**Multiple Reduction Reducers**

Multiple reduction SM-CYCLO® Reducers are a combination of standard reduction mechanism assemblies connected using an intermediate shaft (Part No. 5-01) and intermediate cover (Part No. 55) between them.

**Table A-2. Frame Sizes and Ratio Combination of Double Reduction Models**

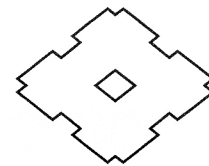
Frame Size Combination

Frame Size	Second Stage	First Stage
6060DA	6060	6060
6065DA	6065	6065
6070DA	6070	6065
6075DA	6075	6065
6090DA	6090	6075
6095DA	6095	6075
6100DA	6100	6075
6105DA	6105	6075
6120DA	6120	6075
6120DB	6120	6095
6125DA	6125	6075
6125DB	6125	6095
6130DA	6130	6075
6130DB	6130	6095
6130DC	6130	6105
6135DA	6135	6075
6135DB	6135	6095
6135DC	6135	6105
6140DA	6140	6075
6140DB	6140	6095
6140DC	6140	6105
6145DA	6145	6075
6145DB	6145	6095
6145DC	6145	6105
6160DA	6160	6095
6160DB	6160	6105
6160DC	6160	6125
6165DA	6165	6095
6165DB	6165	6105

Reduction Ratio Combination

Total Ratio	Second Stage Ratio	First Stage Ratio
104	13	8
121	11	11
143	13	11
165	15	11
195	15	13
231	21	11
273	21	13
319	29	11
377	29	13
473	43	11
559	43	13
649	59	11
731	43	17
841	29	29
1003	59	17
1247	43	29
1479	87	17
1849	43	43
2065	59	35
2537	59	43
3045	87	35
3481	59	59
4437	87	51
5133 <sup>[1]</sup>	87	59
6177	87	71
7569	87	87

Note: [1] For frame sizes 6205DA, DB or DC ~ 6265DA, DB or DC, second stage ratio is 59 and first stage ratio is 87.



# LUBRICATION

## Standard Type Mounted Reducer (Slow Speed Shaft Horizontal)<sup>[1,2]</sup>

Table A-3. Horizontal Mounted Single Reduction Reducers

Reduction Ratio / Frame Size	3	5	6	8	11	13	15	17	21	25	29	35	43	51	59	71	87	119	
6060 6065	Grease Lubricated (G)																		
6070 6075																			
6080 6085																			
6090 6095																			
6100 6105 610H																			
6110 6115																			
6120 6125 612H	Oil Bath Lubrication (PB)																		
6130 6135																			
6140 6145 614H																			
6160 6165 616H																			
6170 6175																			
6180 6185																			
6190 6195																			
6205																			
6215																			
6225																			
6235																			
6245																			
6255																			
6265																			
6275																			

Table A-4. Horizontal Mounted Double Reduction Reducers

Reduction Ratio / Frame Size	104	121	143	165	195	231	273	319	377	473	559	649	731	841	1003	1015	1247	1479	1849	2065	2537	3045	3481	4437	5133	6177	7569	
6060DA 6065DA	Maintenance-Free Grease Lubrication (MF)																											
6070DA 6075DA																												
6090DA 6095DA																												
6100DA 6105DA																												
6120DA 6120DB																												
6125DA 6125DB																												
6130DA 6135DA	Grease Lubrication (G)																											
6130DB 6135DB																												
6130DC 6135DC																												
6140DA 6140DB 6140DC																												
6145DA 6145DB 6145DC																												
6160DA 6165DA																												
6160DB 6165DB																												
6170DA 6175DA																												
6170DB 6175DB																												
6180DA 6185DA																												
6160DC 6165DC	Oil Bath Lubrication (PB)																											
6170DC 6175DC																												
6180DB 6185DB																												
6190DA 6195DA																												
6190DB 6195DB																												
6205DA 6205DB																												
6215DA 6215DB																												
6225DA 6225DB																												
6235DA 6235DB																												
6245DA 6245DB																												
6255DA 6255DB																												
6265DA																												
6275DA																												

Notes: [1] Tables A-3 and A-4 show the standard lubrication method when the Cyclo drive is driven at the standard input speed.  
 [2] Ratios shown in white in Tables A-3 and A-4 are unavailable for the given unit sizes.

# LUBRICATION

## Standard Vertical Mounted Reducer (Slow Speed Shaft Vertical)<sup>[1,2,3]</sup>

Table A-5. Vertical Mounted Single Reduction Reducer

Reduction Ratio / Frame Size	3	5	6	8	11	13	15	17	21	25	29	35	43	51	59	71	87	119															
6060 6065	Grease Lubricated (G)		Maintenance-Free Grease Lubrication (MF)													59																	
6070 6075																87																	
6080 6085																																	
6090 6095																																	
6100 6105																																	
6110 6115																																	
6120 6125																																	
6130 6135																																	
6140 6145																																	
6160 6165																																	
6170 6175																																	
6180 6185																																	
6190 6195																																	
6205																																	
6215																																	
6225																																	
6235																																	
6245																																	
6255																																	
6265																																	
6275													TP		TP		TP		TP														

TP: Positive Displacement Pump Lubrication (see Table A-16.)

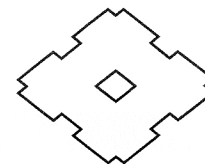
Table A-6. Vertical Mounted Double Reduction Reducer

Reduction Ratio / Frame Size	104	121	143	165	195	231	273	319	377	473	559	649	731	841	1003	1015	1247	1479	1849	2065	2537	3045	3481	4437	5133	6177	7569	
6060DA 6065DA																												
6070DA 6075DA																												
6090DA 6095DA																												
6100DA 6105DA																												
6120DA 6120DB 6125DA 6125DB																												
6130DA 6135DA																												
6130DB 6135DB																												
6130DC 6135DC																												
6140DA 6140DB 6140DC																												
6145DA 6145DB 6145DC																												
6160DA 6165DA																												
6160DB 6165DB																												
6170DA 6175DA																												
6170DB 6175DB																												
6180DA 6185DA																												
6160DC 6165DC										473																		
6170DC 6175DC														841														
6180DB 6185DB																												
6190DA 6195DA																												
6190DB 6195DB																												
6205DA 6205DB																												
6215DA 6215DB		121																										
6225DA 6225DB																												
6235DA 6235DB																												
6245DA 6245DB																												
6255DA 6255DB																												
6265DA																												
6275DA																												

TP: Positive Displacement Pump Lubrication (see Table A-16)

- Notes: [1] Please consult the factory for applications where the slow speed shaft is up.
- [2] Tables A-5 and A-6 show the standard lubrication method when the Cyclo drive is driven at the standard input speed.
- [3] Ratios shown in white in Tables A-5 and A-6 are unavailable for the given unit sizes.





## Lubricants

### Grease Lubricated Models

Those models listed in Tables A-3 ~ A-6 as grease lubricated are filled with grease before shipment to the customer and are ready for use.

**Table A-7. Standard Greases<sup>[1]</sup>**

Ambient Temperature <sup>[2]</sup>		Cyclo® Disc-Type	Cyclo® Planetary-Type
°F	°C		
14 to 122	-10 to 50	Exxon Unirex N2 Grease	Shell Gadus S2 V220 0 Grease

**Table A-8. Grease Replenishment and Change Interval**

Model	Condition	Interval <sup>[3]</sup>	
Maintenance Free Type: Single (6060 to 6125) Double Reduction (6065DA to 6125DB)	Replenishment	NOT REQUIRED	
	Overhaul <sup>[4]</sup>	Every 20,000 Hours or Every 4 ~ 5 Years	
Non- Maintenance Free Type	Replenishment	Less Than 10 Hours Per Day Operation	Every 3 ~ 6 Months
		10 ~ 24 Hours Per Day Operation	Every 500 ~ 1000
	Change	Speed Reducer Mechanism, High Speed Shaft Bearings (Speed Reducer Type)	Every 2 ~ 3 Years
		Slow Speed Shaft Bearings	Every 3 ~ 5 Years

### Replenishment and Change Guidelines

Those units designated as maintenance free in Tables A-3 ~ A-6 do not require replenishment when supplied with standard greases. Certain optional greases do require replenishment. Those units will have a Zerk fitting either on the high speed endshield or near the input shaft bearing housing.

Replenish grease to the reduction mechanism with 1/3 to 1/2 of the quantity listed in Table A-9 or A-10 at the interval recommended in Table A-8. Remove the drain plug from gearbox output section. Replenish grease through the Zerk fitting. After inserting the recommended amount of grease run the unit for five or 10 minutes to circulate the grease and purge any excess. Replace the drain plug and return to service.

When the unit is disassembled for overhauling, refill with the grease quantities indicated in Table A-9 or A-10. Or alternatively, 80% of the space around the reduction mechanism and slow speed shaft

bearings of single reduction units, and 50% around the reduction mechanism of both the first and second stage of double reduction units.

Apply grease liberally to the central part (i.e., around the eccentric bearings) of the mechanism. Apply grease to both the slow speed and high speed shaft bearings as you would to ordinary bearings at the time or re-assembly.

If excessive grease is added, agitation heating of the grease will raise the operating temperature of the unit. Avoid excessive greasing, but do not supply an insufficient amount of grease. When the grease is insufficient, it will raise the unit's operating temperature due to breakdown of the lubrication films on the eccentric bearing. In this case, if the operating temperature rises, supply grease immediately.

**Table A-9. Single Reduction Grease Quantities<sup>[5]</sup> oz. (g.)**

Frame Size	6060 6065	6070 6075	6080 6085	6090 6095	6100 6105 610H	6110 6115	6120 6125 612H
Speed Reduction Mechanism	0.9 (25)	1.4 (40)	2.1 (60)	4.2 (120)	6.7 (190)	8.8 (250)	
Slow Speed Shaft Bearing	0.5 (15)	0.9 (25)	1.1 (30)	1.1 (30)	1.6 (45)	1.9 (55)	

Notes: [1] Avoid the use of grease other than shown in Table A-7. For Food-Grade Lubricants, see Appendix D-3.

[2] Consult the factory when the drives are used under widely fluctuating temperatures, ambient temperatures other than those listed in Table A-7, or any other special conditions.

[3] Single reduction frame sizes 6060 ~ 612H and double reduction frame sizes 6060DA ~ 6125DB are maintenance free units. Grease replenishment is not necessary. Where longer life of the drive is expected or if re-lubricating is preferred before the recommended interval, refer to Tables A-7, A-8, A-9 and A-10.

[4] Overhauling consists of disassembling the unit, replacing the seals and gaskets, cleaning the internal parts and then repacking the unit with designated grease.

[5] For non-standard grease units, refer to page Appendix D-2 for grease quantities

# LUBRICATION

**Table A-10. Double Reduction Grease Quantities – oz. (g.)**

Frame Size	6060DA 6065DA	6070DA 6075DA	6090DA 6095DA	6100DA 6105DA	6120DA 6125DA	6120DB 6125DB	6130DA 6135DA	6130DB 6135DB	6130DC 6135DC	6140DA 6145DA	6140DB 6145DB	6140DC 6145DC
Speed Reduction Mechanism (1st stage)	0.9 (25)					2.1 (60)	0.9 (25)	2.1 (60)		0.9 (25)	2.1 (60)	4.2 (120)
Speed Reduction Mechanism (2nd stage)	0.9 (25)		2.1 (60)	4.2 (120)	8.8 (250)		15.9 (450)					
Slow Speed Shaft Bearing (2nd stage)	0.5 (15)	0.5 (15)	1.1 (30)	1.1 (30)	1.9 (55)		10.6 (300)					

Frame Size	6160DA 6165DA	6160DB 6165DB	6160DC 6165DC	6170DA 6175DA	6170DB 6175DB	6170DC 6175DC	6180DA 6185DA	6180DB 6185DB	6190DA 6195DA	6190DB 6195DB	6205DA	6205DB
Speed Reduction Mechanism (1st stage)	2.1 (60)	4.2 (120)	8.8 (250)	2.1 (60)	4.2 (120)	8.8 (250)	4.2 (120)	15.9 (450)	11.6 (330)	15.9 (450)	11.6 (330)	15.9 (450)
Speed Reduction Mechanism (2nd stage)	26.5 (750)			35.3 (1000)			38.8 (1100)		52.9 (1500)			
Slow Speed Shaft Bearing (2nd stage)	10.6 (300)			17.6 (500)			21.2 (600)		24.7 (700)			

Frame Size	6215DA	6215DB	6225DA	6225DB	6235DA	6235DB	6245DA	6245DB	6255DA	6255DB	6265DA
Speed Reduction Mechanism (1st stage)	15.9 (450)	26.5 (750)	15.9 (450)	35.3 (1000)	26.5 (750)	35.3 (1000)	26.5 (750)	38.8 (1100)	35.3 (1000)	52.9 (1500)	52.9 (1500)
Speed Reduction Mechanism (2nd stage)	70.5 (2000)		88.2 (2500)		141.1 (4000)		158.7 (4500)		211.6 (6000)		282.2 (8000)
Slow Speed Shaft Bearing (2nd stage)	28.2 (800)		31.7 (900)		35.3 (1000)		38.8 (1100)		42.3 (1200)		45.9 (1300)

## Oil Lubricated Models

### Oil Fill Procedure

Oil lubricated models are not filled with oil prior to shipping. Before start-up, remove the oil fill plug (See Pg. A-3, Fig. A-2, Part #28) and fill the reducer with recommended oil. Refer to Tables A-11~A-14 for standard oil, allowable viscosity, quantity, and change interval. The oil level must be to the upper red line on the oil level gauge while the unit is not operating, and above the lower red line during operation. If too much oil is supplied, the unit's operating temperature will rise due to the churning heat of the oil, or oil will leak across the high speed shaft oil seal.

Before filling a vertical base type unit with oil, remove the vent plug (Pg. A-3, Fig. A-2, Part #14). After filling, apply teflon sealing tape to threads of the vent plug before installing.

When draining oil, remove drain plug (Fig. A-5, Part #46) or lower side plug of the oil level gauge.

### Oil Level Gauge

The gauge must be replaced when it becomes difficult to check the oil level due to discoloration of the vinyl hose. Use the standard vinyl oil gauge for a reducer operating in ambient temperature  $-4^{\circ}\text{F}$  to  $100^{\circ}\text{F}$  ( $-20^{\circ}\text{C}$  to  $40^{\circ}\text{C}$ ). Where the reducer is used at ambient temperatures greater than  $100^{\circ}\text{F}$  ( $40^{\circ}\text{C}$ ) or less than  $-4^{\circ}\text{F}$  ( $-20^{\circ}\text{C}$ ), a glass gauge set or a dipstick is recommended.

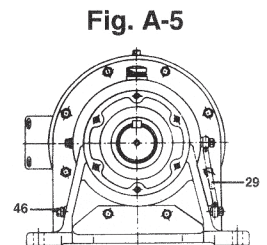
The oil level gauge can be attached on either side of the casing on horizontal units. Attach on the side that is most convenient for checking the oil level. (The oil level gauge is usually attached on the right side when viewed from the slow speed shaft end.)

Planetary-type units use the same oil as that of a Disc-type unit. The grease type differs between Planetary-type units and Disc-type units. Planetary units use Gadus S2 V220 0 grease, while Disc units use standard Unirex N2 grease.

**Table A-11. Approved Oils** <sup>[3]</sup> Oil lubricated reducers must be filled with oil prior to operation. Fill the reducer to the correct level with the recommended oil.

<b>ExxonMobil</b>	Spartan EP	<b>Idemitsu</b>	Daphne Super Gear Oil	<b>BP</b>	Energol GR-XP	<b>Total</b>	Carter EP
<b>Mobil</b>	Mobilgear 600XP	<b>Kluber</b>	Kluberoil GEM1	<b>Castrol</b>	Alpha SP		
<b>Shell</b>	Omala S2 G	<b>Caltex</b>	Meropa	<b>Gulf</b>	EP Lubricant HD		

Ambient Temperature	
$^{\circ}\text{F}$	14      32      50      68      86      104      122
$^{\circ}\text{C}$	-10      0      10      20      30      40      50
<b>ISO VG</b>	68
	100 / 150
	220 / 320 / 460

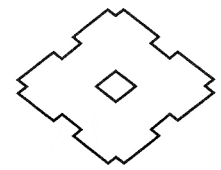


Notes: [1] Use the lower viscosity oil specified for each ambient temperature range for use in winter or relatively low ambient temperatures.

[2] Please consult the factory for consistent use in ambient temperatures other than  $32^{\circ}\text{F}$  -  $104^{\circ}\text{F}$  ( $0^{\circ}\text{C}$  -  $40^{\circ}\text{C}$ ).

[3] For Food-Grade Lubricants, see Appendix D-3.

[4] For approved Synthetic Oils, minimum AGMA Service Factor should be 1.4.



**Table A-12. Oil Fill Quantities<sup>[1]</sup>**

Single Reduction					Double Reduction				
Frame Size	Mounting Configuration				Frame Size	Mounting Configuration			
	Horizontal		Vertical			Horizontal		Vertical	
	U.S. gal.	liter	U.S. gal.	liter		U.S. gal.	liter	U.S. gal.	liter
6130, 6135	0.18	0.7	0.29	1.1	6160DC, 6165DC	0.40	1.5	0.26	1.0
6140, 6145, 614H	0.18	0.7	0.29	1.1	6170DC, 6175DC	0.63	2.4	0.50	1.9
6160, 6165, 616H	0.37	1.4	0.26	1.0	6180DB, 6185DB	0.92	3.5	0.53	2.0
6170, 6175	0.50	1.9	0.50	1.9	6190DA, 6195DA	1.5	5.8	0.71	2.7
6180, 6185	0.66	2.5	0.53	2.0	6190DB, 6195DB	1.6	6.0	0.71	2.7
6190, 6195	1.1	4.0	0.71	2.7	6205DA, 6205DB	1.6	6.0	2.9	11
6205	1.5	5.5	1.5	5.7	6215DA, 6215DB	2.6	10	3.7	14
6215	2.2	8.5	2.0	7.5	6225DA, 6225DB	2.9	11	4.8	18
6225	2.6	10	2.6	10	6235DA, 6235DB	4.5	17	6.1	23
6235	4.0	15	3.2	12	6245DA, 6245DB	4.8	18	7.7	29
6245	4.2	16	4.0	15	6255DA, 6255DB	6.1	23	11.1	42
6255	5.5	21	11.1	42	6265DA	8.5	32	13.5	51
6265	7.7	29	13.5	51	6275DA	15.9	60	(15.9)	(60)
6275	14.8	56	(15.9)	(60)					

( ) with trochoid pump

**Table A-13. Allowable Oil Viscosity**

Minimum Allowable Viscosity To Maintain Lubricating Oil Film		80 SUS During Operation	
Maximum Allowable Viscosity To Allow Easy Starting	Oil Bath	20,000 SUS At Operation Start	
	Forced Oil Lubrication	10,000 SUS At Operation Start	

**Table A-14. Oil Change Interval**

Oil Change Interval		Operation Condition
Initial Oil Change	After 500 Hours of Primary Operation	Under Every Condition
Subsequent Oil Change	Every 6 Months	Less Than 10 Hours/Day Operation
	Every 2,500 Hours	10 ~ 24 Hours/Day Operation
	Every 1 ~ 3 Months	High Ambient Temperature, High Humidity or Atmosphere of Active Gas

**Forced Lubrication For Vertical Units**

**Table A-15. Plunger Pump Type**

Small Size Pump		Large Size Pump	
Frame Size	Ratio	Frame Size	Ratio
6160, 6165, 6170, 6175, 6180, 6185, 6190, 6195	See Table A-5	6205, 6215, 6225, 6235, 6245, 6255, 6265, 6275	See Table A-5
6160DC, 6165DC, 6170DC, 6175DC, 6180DB, 6185DB, 6190DA, 6195DA, 6190DB, 6195DB	See Table A-6	6205DA, 6205DB, 6215DA, 6215DB, 6225DA, 6225DB, 6235DA, 6235DB, 6245DA, 6245DB, 6255DA, 6255DB, 6265DA	See Table A-6

**Plunger Pump Lubrication**

The plunger pump (Fig. A-2, Part #42) is automatically operated by a cam (Fig. A-2, Part #40) fitted on the slow speed shaft (Fig. A-2, Part #1-01). The number of pumping cam teeth required is in direct relation to the reduction ratio and frame size. Please consult the factory for input speeds other than standard.

**Table A-16. Positive Displacement (Trochoid) Pump Type**

Cyclo Drive			Trochoid Pump <sup>[2,3]</sup>									
Type	Frame Size	Reduction Ratio	Pump Type	Pump Motor	50 Hz Zone				60 Hz Zone			
					Flow		Max. Pressure		Flow		Max. Pressure	
					gal/min	l/min	psi	kgf/cm <sup>2</sup>	gal/min	l/min	psi	kgf/cm <sup>2</sup>
Vertical Shaft	6275	29, 43, 59, 87	TOP216HA-VB3	1 HP (0.75 kW) 4P	6.3	24.0	113.8	8	7.6	28.8	71.1	5.0
	6275DA	All	TOP204HA-VB3	1/2 HP (0.4 kW) 4P	1.6	6.0	227.6	16	1.9	7.2	163.6	11.5

**Positive Displacement (Trochoid) Pump Lubrication**

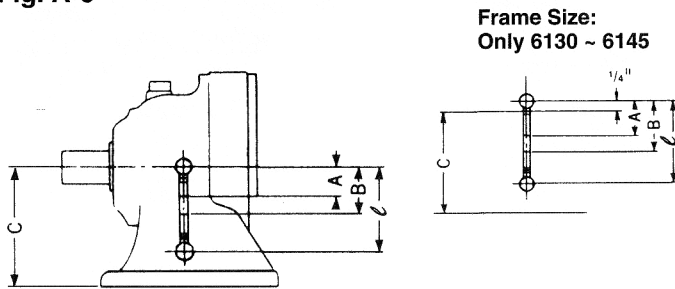
Forced oil lubrication is accomplished by using a positive displacement pump and motor that requires an additional electric power source. It is recommended that the main

motor be interlocked with the pump motor to avoid operation without lubrication. The pump must be started 30 seconds or longer before the main motor is operated.

Notes: [1] Please consult the factory for oil quantities when the reducer/gearmotor is mounted in any other position or angle.  
 [2] Consult the factory when using an inverter.  
 [3] A relief valve, pressure set at 42.7 psi (3 kgf/cm<sup>2</sup>), is a standard attachment on the trochoid pump.

# OIL LEVEL DIMENSIONS

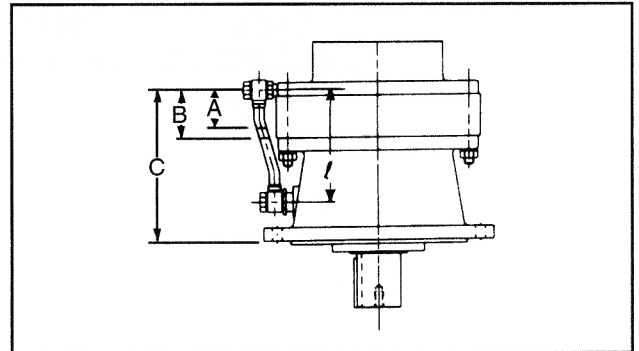
**Foot Mount Horizontal Type**  
Fig. A-6



**Table A-17. Oil Level Dimensions (Inches)**

Frame Size	A	B	C	ℓ
6130-6135	1.38	2.17	5.91	4.65
6140, 6145, (614H)	1.38	2.17	5.91 (6.30)	4.65
6160-6165, (616H)	1.57	2.76	6.30 (7.87)	3.70
6160DC-6165DC	1.18	1.77	6.30	3.70
6170-6175	1.97	3.35	7.87	4.96
6170DC-6175DC	1.18	1.77	7.87	4.96
6180-6185	2.17	3.94	8.66	5.91
6180DB-6185DB	1.38	2.17	8.66	5.91
6190-6195	2.26	3.25	9.84	6.61
6190DA-6195DA	1.18	1.77	9.84	6.61
6190DB-6195DB	1.38	2.18	9.84	6.61
6205	2.12	3.19	9.84	6.06
6205DA	1.26	1.93	9.84	6.06
6205DB	1.26	2.13	9.84	6.06
6215	2.05	3.03	10.84	6.85
6215DA	1.18	1.97	10.43	6.85
6215DB	1.57	2.76	10.43	6.85
6225	2.25	3.43	11.03	6.85
6225DA	1.26	2.05	11.03	6.85
6225DB	1.85	3.43	11.03	6.85
6235	2.48	3.47	11.81	7.64
6235DA	1.57	2.75	11.81	7.64
6235DB	1.97	3.35	11.81	7.64
6245	2.76	3.78	13.19	8.46
6245DA	1.65	2.72	13.19	8.46
6245DB	2.00	3.35	13.19	8.46
6255	3.19	4.17	14.76	9.02
6255DA	1.97	3.35	14.76	9.02
6255DB	2.05	3.23	14.76	9.02
6265	3.23	4.21	15.75	10.16
6265DA	2.28	3.27	15.75	10.16
6275	3.35	4.53	21.26	11.22
6275DA	2.26	3.25	21.26	11.22

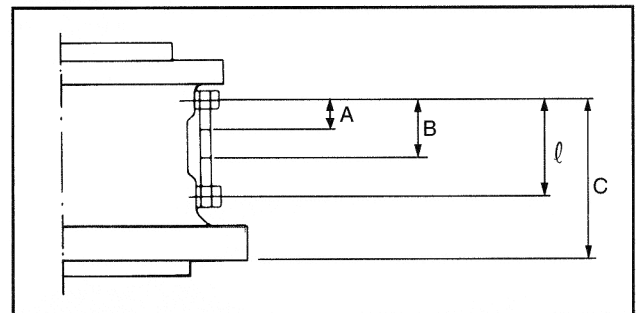
**Base Mount Vertical Type**  
Frame Size: 6130 ~ 614H  
Fig. A-7



**Base Mount Vertical Type**  
**Table A-18. Oil Level Dimensions (Inches)**  
Frame Size: 6130 ~ 614H

Frame Size	A	B	C	ℓ
6130-614H	1.85	2.72	7.52	5.79

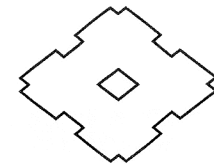
**Base Mount Vertical Type**  
Frame Size: 6160 ~ 6275  
Fig. A-8



**Base Mount Vertical Type**  
**Table A-19. Oil Level Dimensions (Inches)**  
Frame Size: 6160 ~ 6275

Frame Size	A	B	C	ℓ
6160-6165, 616H	1.02	1.42	4.68	2.72
6170-6175	1.69	2.48	6.02	3.78
6180-6185	1.93	2.72	6.81	4.25
6190-6195	2.09	3.27	7.87	5.47
6205	1.46	2.05	7.09	3.54
6215	1.46	2.05	7.09	3.54
6225	1.46	2.05	7.87	3.54
6235	1.46	2.05	7.72	3.54
6245	1.46	2.05	7.96	3.54
*6255	4.33	4.92	19.76	6.57
*6265	4.65	5.24	21.69	7.17
6275	1.97	2.76	13.39	5.51

\*Note: V6255 & V6265 Oil Gauge is on the Ring Gear Housing instead of V-Casing.



# BEARINGS, OIL SEALS, GASKETS

Fig. A-9

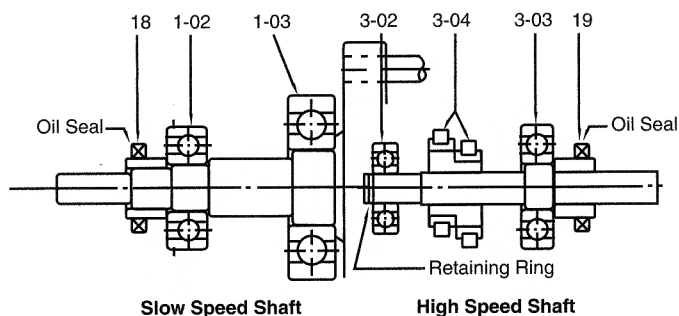


Table A-20. Slow Speed Shaft Bearing

Frame Size		Slow Speed Shaft	
Single Reduction	Double Reduction	Bearing A Part #1-02	Bearing B Part #1-03
6060, 6065	6060DA, 6065DA	6204Z	6909
6070, 6075	6070DA, 6075DA	6204Z	6909
6080, 6085	-	6305Z	6009
6090, 6095	6090DA, 6095DA	6306Z	16011
6100, 6105, 610H	6100DA, 6105DA	6306Z	16011
6110, 6115	-	6307Z	6011
6120, 6125, 612H	6120DA, 6125DA, 6120DB, 6125DB	6308Z	6013
6130, 6135	6130DA, 6135DA, 6130DB, 6135DB, 6130DC, 6135DC	6211NR	6213
6140, 6145, 614H	6140DA, 6145DA, 6140DB, 6145DB, 6140DC, 6145DC	22211EXNR	6213
6160, 6165	6160DA, 6165DA, 6160DB, 6165DB, 6160DC, 6165DC	3TM-6213NR <sup>[1]</sup>	6215 <sup>[1]</sup>
6170, 6175	6170DA, 6175DA, 6170DB, 6175DB, 6170DC, 6175DC	6216NR <sup>[1]</sup>	6218 <sup>[1]</sup>
6180, 6185	6180DA, 6185DA, 6180DB, 6185DB	6218NR <sup>[1]</sup>	6220 <sup>[1]</sup>
6190, 6195	6190DA, 6195DA, 6190DB, 6195DB	6221NR <sup>[1]</sup>	6026 <sup>[1]</sup>
6205	6205DA, 6205DB	22220BNRC2	6222C2
6215	6215DA, 6215DB	23022BNRC2	6224C2
6225	6225DA, 6225DB	23024BNRC2	6226C2
6235	6235DA, 6235DB	23026BNRC2	NUP228C2
6245	6245DA, 6245DB	23028BNRC2	NUP230C2
6255	6255DA, 6255DB	23032BNRC2	NUP234C2
6265	6265DA	23034BNRC2	NUP236C2
6275	6275DA	23136BNXR	6340

Table A-21. High Speed Shaft Bearing

Frame Size		High Speed Shaft			Qty.
Single Reduction	Double Reduction	Bearing C Part #3-02	Bearing D Part #3-03	Eccentric Part #3-04	
6060, 6065	6060DA, 6065DA, 6070DA, 6075DA	6301	6301Z	607YXX	1
6070, 6075	6090DA, 6095DA, 6100DA, 6105DA, 6120DA, 6125DA, 6130DA, 6135DA, 6140DA, 6145DA	6301	6301Z	607YXX	1
6080, 6085	-	6301SH	6302Z	6004RSH2ZZC3	1
6090, 6095	6120DB, 6125DB, 6130DB, 6135DB, 6140DB, 6145DB, 6160DA, 6165DA, 6170DA, 6175DA	6302RSH2	6302Z	Refer to Table A-22	1
6100, 6105, 610H	6130DC, 6135DC, 6140DC, 6145DC, 6160DB, 6165DB, 6170DB, 6175DB, 6180DA, 6185DA	6302RSH2	6302Z		
6110, 6115	-	6302RSH2	6302Z	611YSS, 611GSS	2
6120, 6125, 612H	6160DC, 6165DC, 6170DC, 6175DC, 6190DA, 6195DA, 6205DA	6304	6305Z	Refer to Table A-22	1
6130, 6135	6180DB, 6185DB, 6190DB, 6195DB, 6205DB, 6215DA, 6225DA	6305	6306		
6140, 6145, 614H	-	6305R	6306		
6160, 6165, 616H	6215DB, 6235DA, 6245DA	6307R	6308		
6170, 6175	6255DA, 6255DB	6406	6407	617YSX	2
6180, 6185	6235DB, 6245DB	6407	6409	618YSX	2
6190, 6195	6255DB, 6265DA, 6275DA	6408	6411	619YSX	2
6205	-	NJ310EV7	21311V1	620GXX	2
6215	-	NJ311EV16	21311V1	621GXX	2
6225	-	NJ312EV11	21312V1	622GXX	2
6235	-	NJ313EV11	21314V1	623GXX	2
6245	-	NJ314EV7	21315V1	624GXX	2
6255	-	NJ316EV1	21318V1	625GXX	2
6265	-	NJ317EV1	21318V1	626GXX	2
6275	-	NJ417	22222BL1	627GXX	2

Note: [1] For grease lubricated models, a sealed bearing should be used, which changes the following letters in the part number to those shown in bold: NR (Std.) - **ZNR**; NXR - **ZNXR**; None - add **Z**.

# BEARINGS, OIL SEALS, GASKETS

Fig. A-10

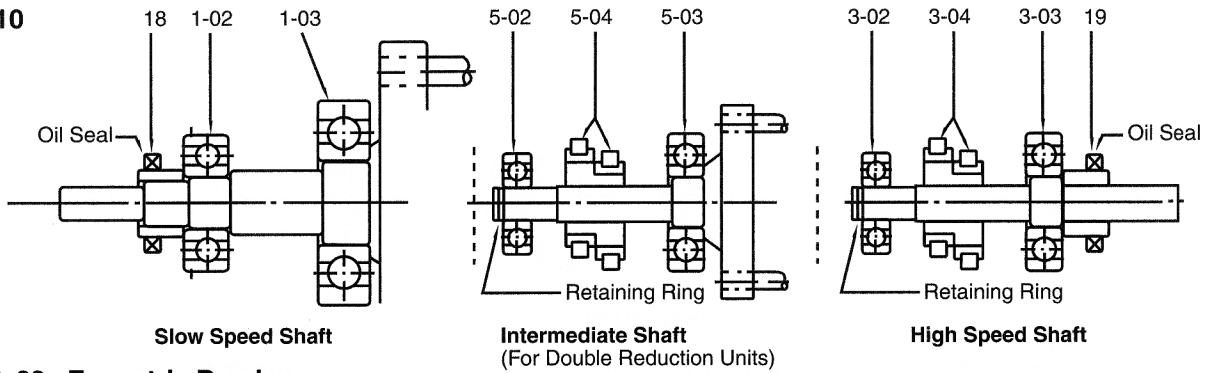
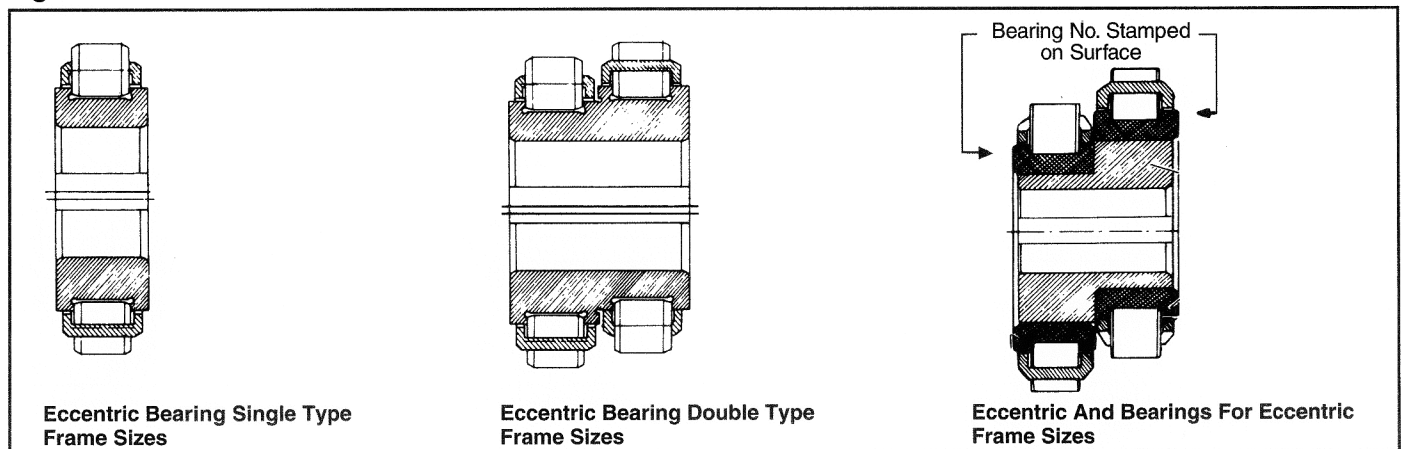
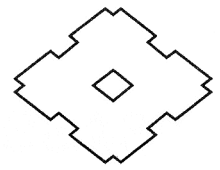


Table A-22. Eccentric Bearing

		Frame Size					
High Speed Shaft, Motor Shaft Part #3-04	6090, 6095	6100, 6105	6120, 6125	6130, 6135	6140, 6145	6160, 6165	
Intermediate Shaft Part #5-04	6090DA 6095DA	6100DA 6105DA	6120DA, 6125DA 6120DB, 6125DB	6130DA, 6135DA 6130DB, 6135DB 6130DC, 6135DC	6140DA, 6145DA 6140DB, 6145DB 6140DC, 6145DC	6160DA, 6165DA 6160DB, 6165DB 6160DC, 6165DC	
Reduction Ratio							
6	60906YRX	6100608YRX	6120608YRX	61406-11YSX	61406-11YSX	6160608YRX2	
8	60908-15YSX	6100608YRX	6120608YRX	61406-11YSX	61406-11YSX	6160608YRX2	
11	60908-15YSX	61011-15YRX	6121115YSX	61406-11YSX	61406-11YSX	61611-15YSX	
13	60908-15YSX	61011-15YRX	6121317YSX	61413-17YSX	61413-17YSX	61611-15YSX	
15	60908-15YSX	61011-15YRX	6121115YSX	61413-17YSX	61413-17YSX	61611-15YSX	
17	60917YSX	61017YSX	6121317YSX	61413-17YSX	61413-17YSX	61617-25YSX	
21	60921YSX	61021YRX	61221YRX	6142125YSX	6142125YSX	61617-25YSX	
25	6092529YSX	6102529YRX	6122529YSX	6142125YSX	6142125YSX	61617-25YSX	
29	6092529YSX	6102529YRX	6122529YSX	6142935YSX	6142935YSX	6162935YSX	
35	60935YSX	61035YRX	61235YRX	6142935YSX	6142935YSX	6162935YSX	
43	60943YSX	61043YSX	61243YSX	61443-59YSX	61443-59YSX	6164351YSX	
51	60951YRX	61051YRX	6125159YSX	61443-59YSX	61443-59YSX	6164351YSX	
59	60959YSX	61059YRX	6125159YSX	61443-59YSX	61443-59YSX	61659YSX	
71	60971YRX	61071YRX	6127187YSX	6147187YSX	6147187YSX	61671YRX2	
87	60987YSX	61087YRX	6127187YSX	6147187YSX	6147187YSX	61687YSX	
119	609119YSX	610119YSX	-	-	-	-	

Fig. A-11





**Table A-23. Intermediate Shaft Bearing**

Frame Size	Intermediate Shaft				Frame Size	Intermediate Shaft				
	Bearing F Part #5-02	Bearing G Part #5-03	Eccentric Bearing Part #5-04	Qty.		Bearing F Part #5-02	Bearing G Part #5-03	Eccentric Bearing Part #5-04	Qty.	
6060DA, 6065DA	6301	6909	607YXX	1	6180DA, 6185DA	6407	6208	618YSX	2	
6070DA, 6075DA	6301	6909	607YXX	1	6180DB, 6185DB	6407	6213	618YSX	2	
6090DA, 6095DA	6302RSH2	6007	Refer to Table A-22	1	6190DA, 6195DA	6408	6210	619YSX	2	
6100DA, 6105DA	6302RSH2	6007			6190DB, 6195DB	6408	6213	619YSX	2	
6120DA, 6125DA	6304	6007			6205DA	NJ310EV7	6210	620GXX	2	
6120DB, 6125DB	6304	6205			6205DB	NJ310EV7	6310	620GXX	2	
6130DA, 6135DA	6305	6007			6215DA, 6215DB	NJ311EV16	6311	621GXX	2	
6130DB, 6135DB	6305	6206			6225DA, 6225DB	NJ312EV11	6313	622GXX	2	
6130DC, 6135DC	6305	6206			6235DA, 6235DB	NJ313EV11	6314	623GXX	2	
6140DA, 6145DA	6305	6007			6245DA	NJ314EV7	6315	624GXX	2	
6140DB, 6145DB	6305	6206			6245DB	NJ314EV7	6316	624GXX	2	
6140DC, 6145DC	6305	6206			6255DA, 6255DB	NJ316EV1	6318	625GXX	2	
6160DA, 6165DA	6307R	6207			6265DA	NJ317EV1	6320	626GXX	2	
6160DB, 6165DB					6275DA	NJ417	22220RH	627GXX	2	
6160DC, 6165DC	6307R	6208								
6170DA, 6175DA	6406	6207			617YSX	2				
6170DB, 6175DB										
6170DC, 6175DC	6406	6208			617YSX	2				

**Table A-24. Oil Seals**

Frame Size	Slow Speed Shaft Part #18				High Speed Shaft Part #19		
	Type <sup>[1]</sup>	Dimension (mm)	Quantity		Type <sup>[1]</sup>	Dimension (mm)	Quantity
		(I.D. x O.D. x W)	Horizontal Shaft	Vertical Shaft		(I.D. x O.D. x W)	
6060, 6065	D	30 x 47 x 8	1	1	S	17 x 30 x 6	1
6070, 6075	D	30 x 47 x 8	1	1	S	17 x 30 x 6	1
6080, 6085	D	45 x 62 x 9	1	1	S	17 x 30 x 6	1
6090, 6095	D	50 x 72 x 12	1	1	S	20 x 35 x 7	1
6100, 6105	D	50 x 72 x 12	1	1	S	20 x 35 x 7	1
6110, 6115	D	55 x 80 x 12	1	1	S	20 x 35 x 7	1
6120, 6125	D	65 x 90 x 13	1	1	D	32 x 52 x 8	1
6130, 6135	D	68 x 88 x 12	1	2	D	38 x 58 x 11	1
6140, 6145	D	65 x 88 x 12	1	2	D	38 x 58 x 11	1
6160, 6165	D	85 x 110 x 13	1	2	D	55 x 78 x 12	1
6170, 6175	D	95 x 130 x 15	1	2	D	60 x 82 x 12	1
6180, 6185	D	110 x 145 x 15	1	2	D	65 x 88 x 12	1
6190, 6195	D	120 x 155 x 16	1	2	S	70 x 88 x 10	1
6205	D	120 x 155 x 16	1	2	S	70 x 88 x 10	1
6215	D	130 x 160 x 14	1	2	S	75 x 100 x 13	1
6225	D	145 x 175 x 14	1	2	S	75 x 100 x 13	1
6235	D	160 x 190 x 16	1	2	S	85 x 110 x 13	1
6245	D	170 x 200 x 16	1	2	S	95 x 120 x 13	1
6255	D	190 x 225 x 16	1	2	S	110 x 140 x 14	1
6265	D	200 x 240 x 20	1	2	S	110 x 140 x 14	1
6275	D	230 x 270 x 20	1	2	S	120 x 150 x 14	1

Note: [1] D indicates lip (dust proof and seal lip) type.

# DISASSEMBLY/ASSEMBLY

---

## Disassembly

SM-CYCLO® Reducers are designed to provide maximum ease when disassembling and reassembling; they require no special maintenance skills.

1. Remove the complete SM-CYCLO® Reducer with adaptor (motorized type) from the driven machine.
  2. Remove the plug at the bottom of the oil gauge to drain all oil from the unit.
  3. Remove the cooling fan cover and fan from those Speed Reducers (not motorized) equipped with a cooling fan, and stand the unit on a solid base with its high speed shaft side down. Remove the through bolts for the high speed end shield, ring gear housing, and lift the slow speed side, thus separating the unit into two parts so that the inner mechanism can be removed (Figs. A-12 ~ A17).
- Note:** If the reducer is motorized (C-adaptor and coupling) remove the motor and coupling before following the procedure outlined above. As a final step, remove the adaptor and cooling fan.
4. If the unit will not separate easily, gently drive a wedge at the line X shown in Fig. A-1 on page A-3 (if this produces a burr, be sure to remove it before reassembly).
  5. To lift the slow speed side, attach an eyebolt to the tapped hole on the end of the slow speed shaft and use a hoist or chain block (Fig. A-12).
  6. Take out the slow speed shaft rollers, item 1-06, page A-3 (Fig. A-13). Check the slow speed shaft pins (1-01) to see whether any rollers have adhered to them.
  7. Using both hands, lift out the top cycloid disc (2-04) on the slow speed side (Fig. A-14).

8. Remove the spacer ring (2-05).
  9. The eccentric (3-04) can be removed from the input shaft (3-01) after taking out the retaining ring (3-10) and the inner bearing raceway (Figs. A-15, A-16).
- Note:** In certain sizes, the eccentric bearings are roller bearings without a retainer. Remove bearings of the top disc before proceeding with the next step.
10. Take out the second disc located on the motor side. (Also remove second disc bearings and eccentric with inner bearing raceway if required.)
  11. Remove the ring gear housing (2-01).
  12. Follow these steps to remove the slow speed shaft (1-01) with its bearings from the casing (26): (a) Remove the horizontal oil seal housing (25). (b) With a wooden or hard rubber mallet, rap the inner end of the slow speed shaft to expose the retaining ring\* from the outer raceway of the bearing. (c) Remove the retaining ring. (d) Rap the outer end of the slow speed shaft with a wooden or hard rubber mallet, and remove it from the casing.
  13. The high speed shaft (3-01) with bearings is removed from the high speed shaft end shield (8) by tapping the shaft end after first taking off the retaining ring (3-11).
  14. The cycloid disc is made from heat-treated bearing steel and the spacer ring is cast iron. Take care not to strike them together while handling.
- The above instructions cover complete disassembly. In ordinary cases, however, only the removal of the cycloid discs and the eccentric, and removal of the slow speed shaft from the slow speed end cap is necessary.
- \*Note:** Retaining ring is part of bearing A (Part No. 1-02).

---

## Assembly

SM-CYCLO® Reducers are reassembled by reversing the disassembly procedure. Care must be taken to exclude dust or foreign matter from the moving parts, and to see that gaskets are properly placed to make the assembly oil-tight.

Following are some helpful points to remember when assembling SM-CYCLO® Reducers.

1. Set the ring gear housing and insert the ring gear pins and rollers; then test-rotate the pins and rollers by hand. (Apply grease liberally to the ring gear pins and rollers before they are inserted in grease lubricated SM-CYCLO® Reducers.)
2. Cycloid discs are a matched pair. Each carries the same number stamped on one side of the disc.
3. Set the cycloid disc with the stamped number face up as shown in Fig. A-17.
4. Insert the spacer (3-07) and then insert the eccentric with bearings by rapping with a wooden or hard rubber mallet (Fig. A-16).
5. Insert the other spacer and the inner bearing raceway. Secure them with the retaining ring (Fig. A-15).
6. Set the spacer ring in place.
7. **Insert top disc in such a way that the mark is 180° opposed to the mark on the bottom disc (Fig. A-13).**
8. Insert slow speed shaft rollers (Fig. A-13).
9. Put the slow speed shaft pins into the rollers (Fig. A-12). The above instructions are for **eccentric bearings with retainer**. Following are the instructions suggested for **roller bearings without retainer**.
  - a. First insert the eccentric with inner raceways of bearings by rapping with a wooden or hard rubber mallet.



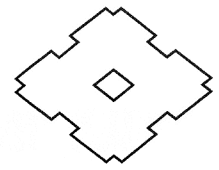


Fig. A-12

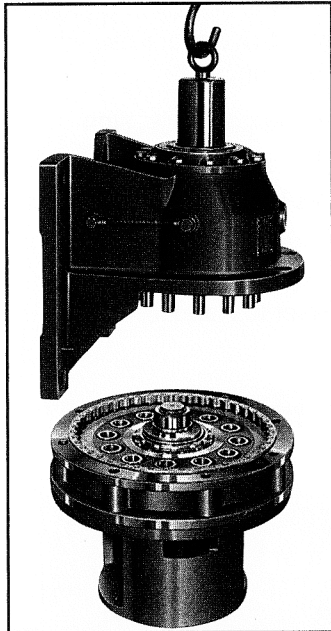


Fig. A-13

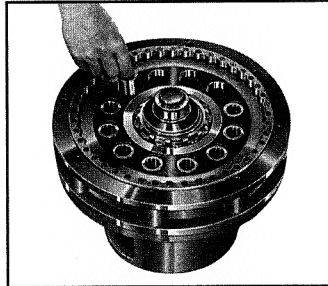


Fig. A-16

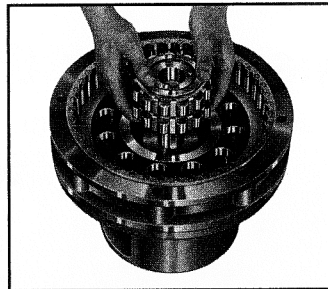


Fig. A-14

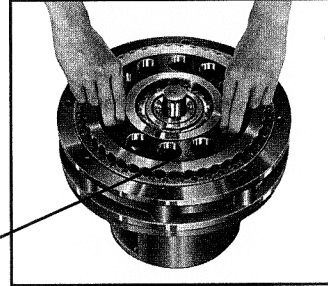


Fig. A-15

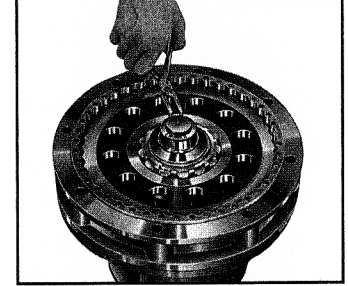
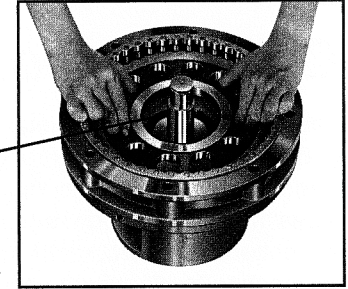


Fig. A-17



**Note:** Insert second disc with number facing slow speed side, exactly 180° opposed to number on first disc.

**Note:** Set disc with number facing slow speed side.

- b. Apply grease to the raceway of the eccentric on the disc. Fix the rollers and set disc in place.
- c. Insert the spacer ring and set second disc in such a way that mark is 180° opposed to mark on the bottom disc.

#### Eccentric Bearing Replacement Precautions

The eccentric bearings are specially designed for installation on SM-CYCLO® Reducers. They are special roller bearings without outer raceways (refer to the list of bearings on pages A-12 ~ A-13).

It is necessary to insert replacement bearings with numbered surfaces of the inner raceways facing outward. Note that incorrect insertion of the bearings (i.e., insertion of bearings with numbered surfaces inside) causes trouble.

#### Disassembly and Assembly of Sizes 6060-6095 SM-CYCLO® Reducers

Small sizes 6060-6095 have a single disc system, so they differ in construction from larger sizes in the following ways:

1. A balance weight is provided in lieu of the two-disc system. Refer to figure A-18.
2. The balance weight must be positioned exactly 180° as opposed to that of the eccentric.
3. There are no end plates on either side of the eccentric. In all other respects, 6060-6095 have exactly the same construction as the larger sizes. Follow the instructions given under "Disassembly and Assembly".

#### Disassembly Of Output Side (6060-612H)

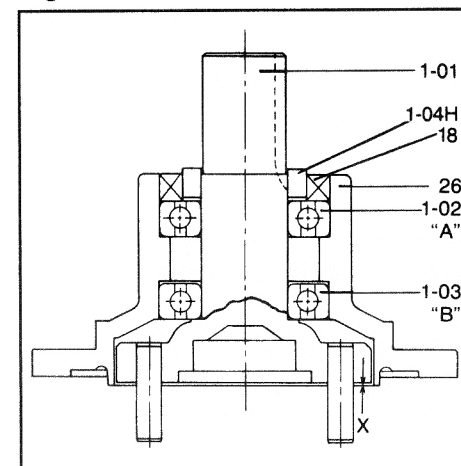
1. With casing supported, tap output shaft until it is disengaged from casing.
2. Remove bearing "A" by using pulling tool.
3. Replace all bearings, gaskets and seals when reassembling. (Pages A-11 ~ A-13).

#### Assembly Of Output Side (6060-612H)

1. Assemble the "B" bearing (Part No. 1-03) on the slow speed shaft (Part No. 1-01). Heating of "B" bearing is recommended for easier assembly.
- Note:** Do not exceed temperature of 200°F.
2. Assemble the casing (Part No. 26) over the slow speed shaft (Part No. 1-01), being sure to maintain "X" (Fig. A-18).
3. Carefully tap bearing "A" (Part No. 1-02) onto the slow speed shaft (Part No. 1-01) until the bearing is flush with the shoulder of the casing.
4. Place the collar (Part No. 1-04H) onto the slow speed shaft (Part No. 1-01). Heating the collar is recommended for easier assembly.
5. Insert the oil seal (Part No. 18), lip in, into the casing (Part No. 26).

**Note:** Measure for dimension "X" preferably in 3 places to insure proper spacing.

Fig. A-18



X" Dimension (inches)

Frame Size	Dimension
6060/65	0.046 ± 0.007
6070/75 6080/85	0.042 ± 0.007
6090/95	0.046 ± 0.007
6100/05 610H	0.046 ± 0.007
6110/15/20/ 25, 612H	0.042 ± 0.007

# DAILY INSPECTION

1. Visually check the oil level gauge on the vertical unit, forced-lubricated type. Check lubrication flow by viewing piping set and oil signal (Part No. 41). Faulty operation is caused by a lack of lubrication oil, damage to the plunger pump (Part No. 42) or the positive displacement pump (Part No. 43) or the clogging of pipes, etc. In case of faulty operation, stop and inspect the unit immediately.

2. A temperature rise of approximately 105°F (40.6°C) above ambient on the surface of the ring gear housing (Part No. 2-01) is allowable if the temperature

fluctuation is small. If temperature rises rapidly from a stable condition, add the recommended oil or grease (Tables A-7 and A-11). A rapid temperature rise may be caused from a lack of lubrication.

If after lubricating unit, the problem persists, stop operation and consult factory.

3. When an abnormal sound is heard from inside the unit, stop operation and inspect the unit.



4. If the lubrication oil leaks, replace the damaged or worn part with a new one. (Refer to Part No. 1-04H, Page A-3.)

## Ordering Correct Replacement Units Or Parts

The SM-CYCLO® is fully standardized to offer maximum part interchangeability among models of the same frame size. However, there are many frame sizes, models and types in the production range of SM-CYCLO®. Therefore to get correct replacement units or parts, proper information to identify the speed reducer in question is essential. The name plate, which is secured to the body of the drive, provides this identifying data.

Please give the full description shown on the name plate to your distributor. Be sure to include the *SERIAL NUMBER* and *MODEL NUMBER*. This information, along with our production records, will enable us to provide you with the correct replacement unit or parts.

Name Plate on SM-CYCLO®

		
MODEL		
RATIO		SERVICE FACTOR
INPUT	HP	RPM
OUTPUT TORQUE		IN-LB
SERIAL NO.		
		

## Storage And Operation After Storage

### Storage 6 Months–1 Year

#### Oil-Lubricated

1. Completely fill unit(s) with a rust-preventive oil (NP20 or equivalent) or a circulating oil (Shell VSI No. 100 or equivalent).

2. At approximately 3 month intervals, rotate the input shaft a sufficient number of times to insure all internal components remain coated. (The higher the ratio, the greater the amount of rotations needed for proper lubrication.)

#### Grease-Lubricated

Grease-lubricated models do not require any special attention during storage. (Inspect unit before operation.)

**Note:** For both the *Oil-Lubricated* and *Grease-Lubricated* models, if units are to be stored for a period exceeding 1 year, consult factory.

### Operation After Storage 6 Months–1 Year

#### Oil-Lubricated

1. Completely drain the rust preventive, or circulating oil from unit.

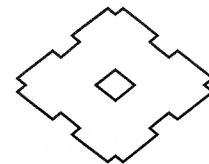
2. Flush unit with the recommended operating oil as shown in Table A-11.

3. After flushing, fill the unit to the proper oil level with the recommended lubricating oil.

#### Grease-Lubricated

Add ½ of the recommended quantity of new grease as shown in Table A-10.

**Note:** Consult the factory before operating units stored for periods greater than 1 year.



# TROUBLESHOOTING AND REPAIR

This troubleshooting guide is to help you identify and overcome common problems of reducers. If you have a problem not listed below, please consult factory.

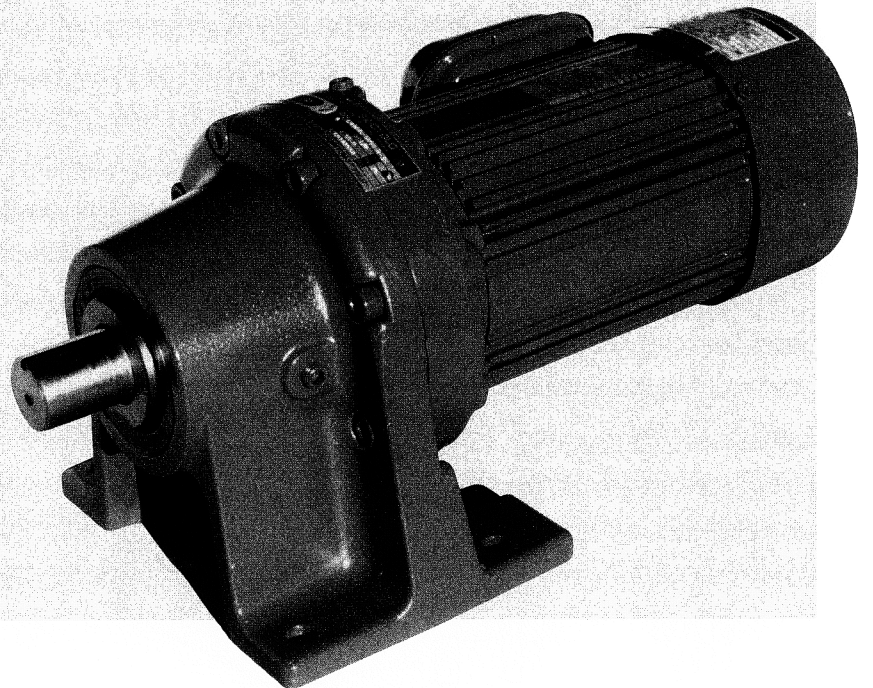
PROBLEM WITH THE REDUCER		POSSIBLE CAUSES	SUGGESTED REMEDY
Runs Hot	Overloading	Load exceeds the capacity of the reducer.	Check rated capacity of reducer, replace with unit of sufficient capacity or reduce load.
	Improper Lubrication	Insufficient lubrication.	Check lubricant level and adjust up to recommended levels.
		Excessive lubrication.	Check lubricant level and adjust down to recommended level.
		Wrong lubricant.	Flush out and refill with correct lubricant as recommended.
Runs Noisy	Loose Foundation Bolts	Weak mounting structure.	Inspect mounting of reducer. Tighten loose bolts and/or reinforce mounting and structure.
		Loose hold down bolts.	Tighten bolts.
	Worn Disc	Overloading unit may result in damage to disc.	Disassemble and replace disc. Recheck rated capacity of reducer.
	Failure of Bearings	May be due to lack of lubricant.	Replace bearing. Clean and flush reducer and fill with recommended lubricant.
		Overload.	Check rated capacity of reducer, replace with unit of sufficient capacity or reduce load.
	Insufficient Lubricant	Level of lubricant in the reducer not properly maintained.	Check lubricant level and adjust to factory-recommended level.
Damaged Pins & Rollers	Overloading of reducer.	Disassemble and replace ring gear pins and rollers. Check load on reducer.	
Output Shaft Does Not Turn	Input Shaft Broken	Overloading of reducer can cause damage.	Replace broken shaft. Check rated capacity of reducer.
		Key missing or sheared off on input shaft.	Replace key.
	Eccentric Bearing Broken	Lack of lubricant.	Replace eccentric bearing. Flush and refill with recommended lubricant.
		Coupling loose or disconnected.	Properly align reducer and coupling. Tighten coupling.
Oil Leakage	Worn Seals	Caused by dirt or grit entering seal.	Replace seals. Breather filter may be clogged. Replace or clean filter.
		Overfilled reducer.	Check lubricant level and adjust to recommended level.
		Vent clogged.	Clean or replace element, being sure to prevent any dirt from falling into the reducer.
	Improper mounting position, such as wall or ceiling mount of horizontal reducer.	Mount horizontally or rework reducer to wall or ceiling mount.	

# NOTES

---

---

# SM-CYCLO® GEARMOTORS



# SECTION B CONTENTS

Mounting of Gearmotor . . . . .	B-2	General Inspection of Motor . . . . .	B-16
General Construction . . . . .	B-3, 4	Pre-Start Up Inspection . . . . .	B-16
SM-CYCLO® Reducer . . . . .	B-5 ~ 13	Preparation and Start-Up . . . . .	B-16
Lubrication . . . . .	B-5 ~ 10	Bearings, Oil Seals for Motor . . . . .	B-17 ~ 19
Grease . . . . .	B-7, 8	Designated Grease . . . . .	B-17
Designated Grease . . . . .	B-7	Intervals and Quantities of Grease . . . . .	B-17
Grease Replenishment and Change . . . . .	B-7	Grease Replenishment Procedure . . . . .	B-17
Quantities of Grease . . . . .	B-7, 8	Oil Seals . . . . .	B-17 ~ 19
Oil Units . . . . .	B-8 ~ 10	Single Lip Type, Slinger Type . . . . .	B-17
Oil Fill Procedure, Oil Gauge . . . . .	B-8	Bearing and Oil Seal Sizes . . . . .	B-18, 19
Standard Oils . . . . .	B-8	SM-CYCLO Gearmotor . . . . .	B-20 ~ 24
Oil Quantities . . . . .	B-9	Disassembly/Assembly . . . . .	B-20, 21
Allowable Oil Viscosity . . . . .	B-9	Troubleshooting-Reducer . . . . .	B-22
Oil Change Interval . . . . .	B-9	Troubleshooting-Motor . . . . .	B-23
Forced Lubrication . . . . .	B-9	Gearmotor Maintenance and Inspection . . . . .	B-24
Oil Level Dimensions . . . . .	B-10	Ordering Correct Replacement Parts . . . . .	B-24
Bearings, Oil Seals and Gaskets . . . . .	B-11 ~ 13	Storage and Operation After Storage . . . . .	B-24
SM-CYCLO Motor . . . . .	B-14 ~ 19		
General Construction . . . . .	B-15		

## Mounting

### 1. Mounting on Exact Planes

The Horizontal Type oil-lubricated units must be mounted on horizontal surfaces. Where they are mounted on inclined surfaces, some modifications may be necessary. Specify mounting plane inclination at time of ordering.

### 2. Accurate Alignment

Where the gearmotor is connected to the driven machine through coupling, align the shafts accurately. Where the gearmotor is connected through V pulleys or sprockets, insure that the belts or chains are neither too tight nor too slack.

### 3. Overhung Load Positions

Overhung loads should be located as close to the bearing as possible. (See the SM-Cyclo 6000 Series Catalog page E-8.)

### 4. Foundations

Foundations must be rugged enough to withstand shock and stress applied from the load side through the gearmotor.

### 5. Secure Housing

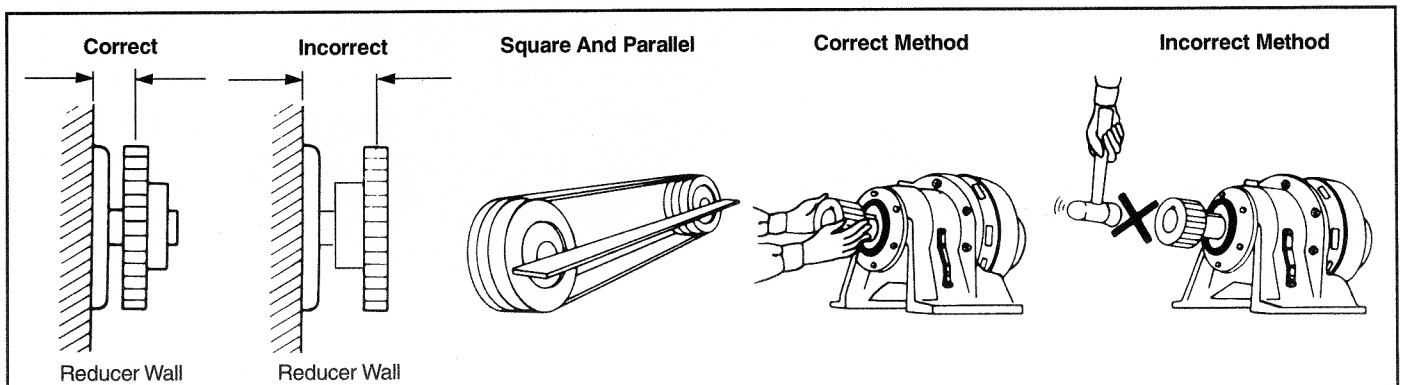
Where the reduction units are operated under conditions of vibration and/or frequent starts and stops, it is recommended to secure them on their mounting surfaces by inserting dowel pins into the knock-holes provided on the foot of the casing. This will insure that bending or shearing forces are reduced on the mounting bolts. Pins must be securely inserted, particularly when the units are to be operated under conditions of severe recurrent peak loads.

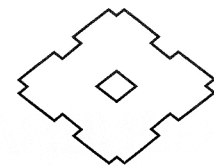
### 6. Mounting Accessibility

The reduction units must be mounted on places with easy accessibility for lubrication maintenance purposes and ease of inspection.

### 7. Ventilation

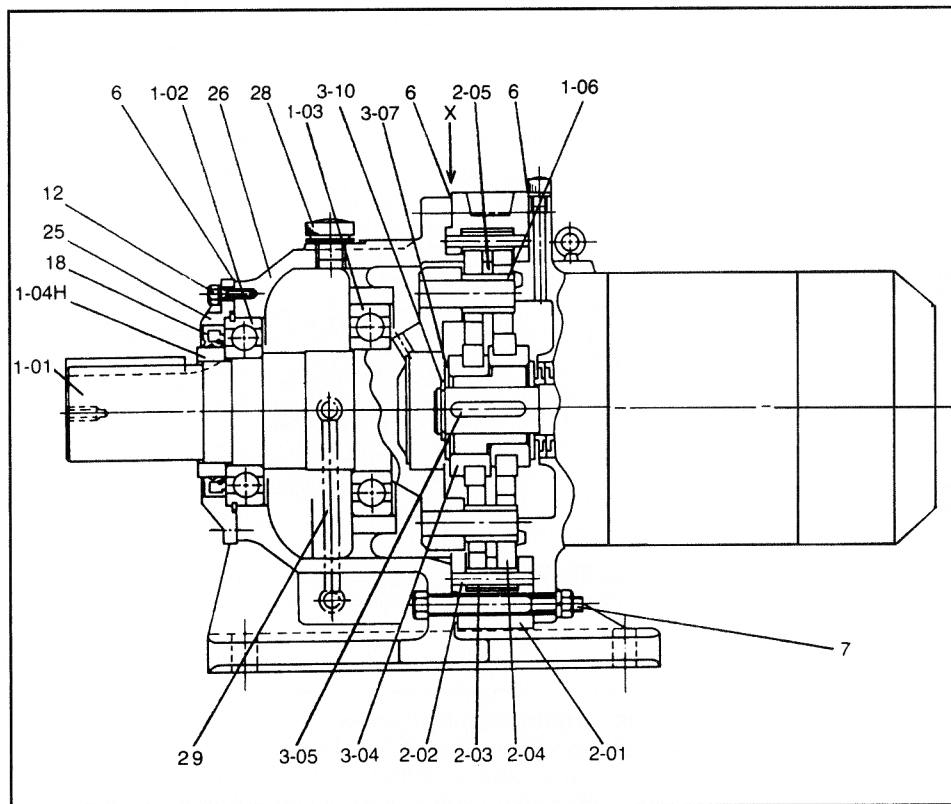
Avoid installation in places where the humidity is high, dust is considerable, or where the gearmotor will be in contact with water or oil. Select a clean, dry location with good ventilation.





# GENERAL CONSTRUCTION

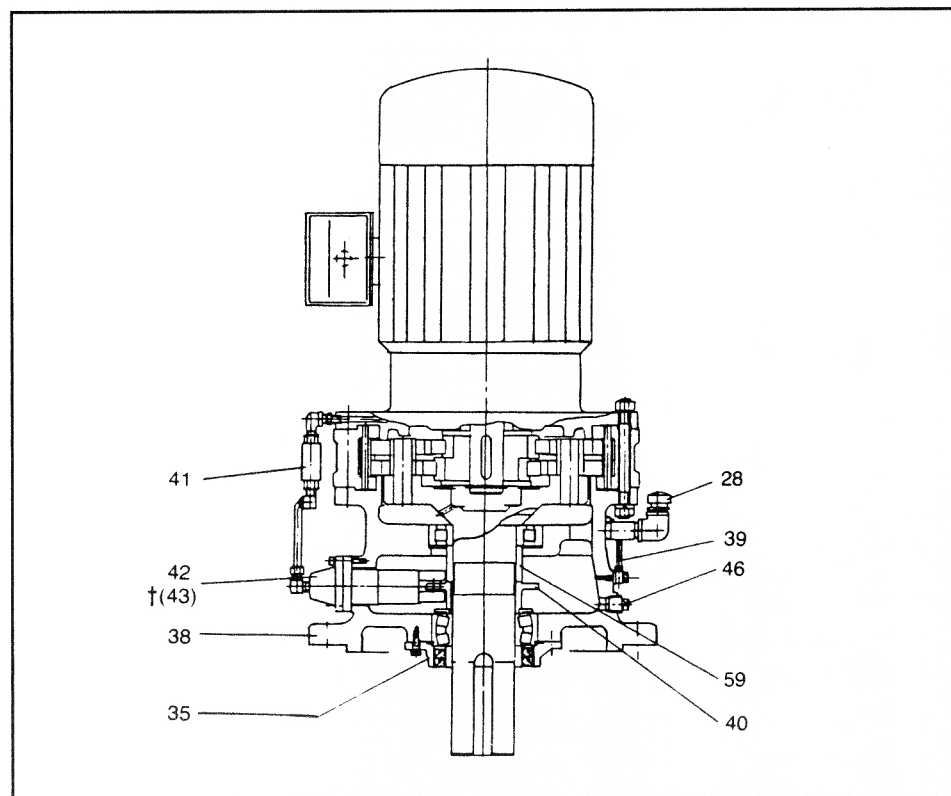
**Fig. B-1 Single Reduction (Horizontal Foot Mount)**



**Table B-1 Main Parts**

Part No.	Part Name
1-01	Slow Speed Shaft w/pins
1-02	Bearing A
1-03	Bearing B
1-04H	Oil Seal Collar—Horizontal
1-06	Slow Speed Shaft Rollers
2-01	Ring Gear Housing
2-02	Ring Gear Pins
2-03	Ring Gear Rollers
2-04	Cyclo Disc
2-05	Spacer Ring
3-04	Eccentric Bearing Assembly
3-05	Eccentric Key
**3-06	Balance Weight
3-07	Spacer
3-10	Retaining Ring
‡5-01	Intermediate Shaft w/Pins
‡5-02	Bearing F
‡5-03	Bearing G
‡5-04	Eccentric Bearing Assembly
6	Gasket Set
7	Casing Nuts & Bolts
12	Bolts For SS Oil Seal Housing
‡15	Grease Nipple
18	Slow Speed Output Oil Seal
25	Horizontal Oil Seal Housing
26	Horizontal Case
28	Oil Fill Plug
29	Oil Gauge—Horizontal Unit
35	Vertical Oil Seal Housing
38	Vertical Case (Integral V Type)
39	Oil Gauge—Vertical Unit
40	Cam
41	Piping Set & Oil Signal
42	Plunger Pump
†43	Positive Displacement Pump
46	Drain Plug
‡55	Intermediate Cover
‡57	Eye Bolt
*59	Spacer

**Fig. B-2 Single Reduction (Vertical Base Mount)**



\* Pt. No. 59 — frame sizes 6205-6275 only.

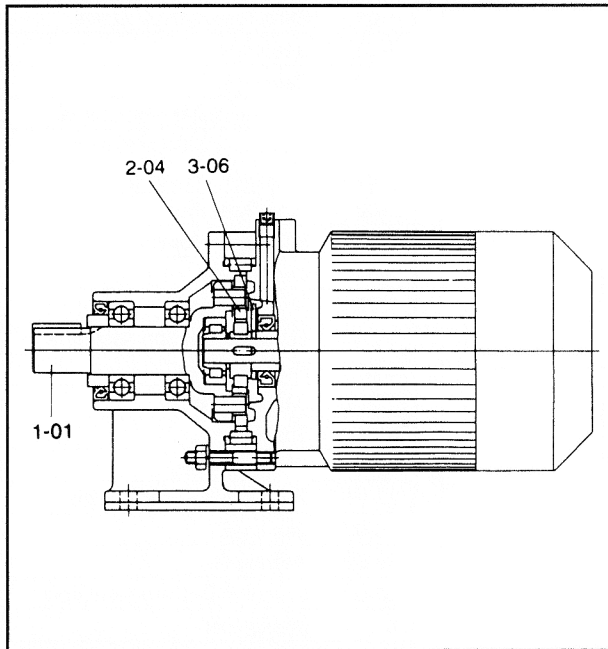
\*\* See Fig. B-3, Page B-4.

‡ See Fig. B-4, Page B-4.

Note: For details of oil seals, bearings or gaskets, refer to pages B-10 and B-11.  
 †Refer to Table B-13 on Pg. B-9 for units that require a positive displacement pump.

# GENERAL CONSTRUCTION

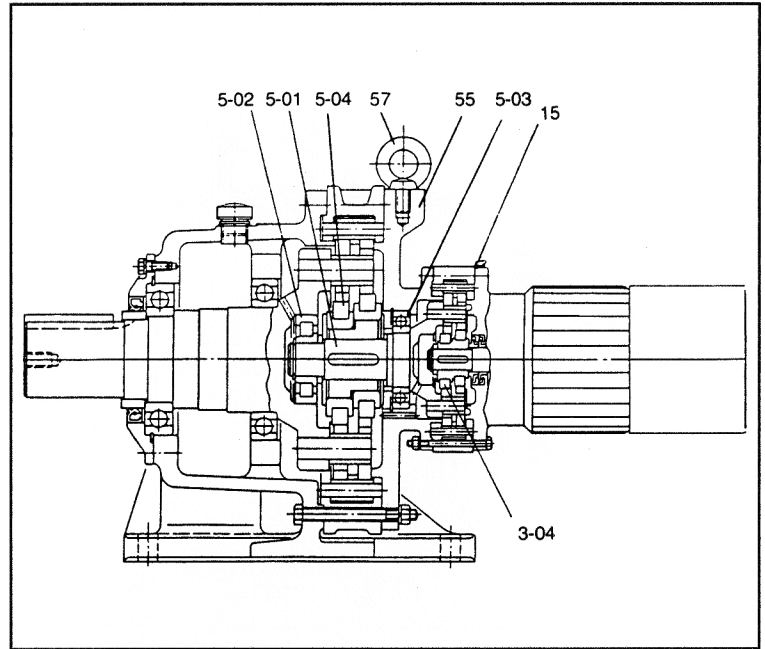
**Fig. B-3 Gearmotor/Single Disc Type (Frame Size 6060-6095)**



**Speed Reducer — Single Disc**

SM-CYCLO single reduction, Models No. 6060-6095 employ the use of a single planetary gear (Cycloid Disc) and a balance weight.

**Fig. B-4 Gearmotor/Double Reduction**



**Multiple Reduction Reducers**

Multiple reduction SM-CYCLO Reducers are a combination of standard reduction mechanism assemblies connected using an intermediate shaft (Part No. 5-01) and intermediate cover (Part No. 55) between them.

**Table B-2. Frame Sizes and Ratio Combination of Double Reduction Models**

**Frame Size Combination**

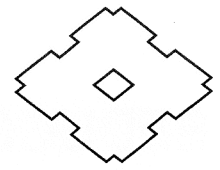
Frame Size	Second Stage	First Stage
6060DA	6060	6060
6065DA	6065	6065
6070DA	6070	6065
6075DA	6075	6065
6090DA	6090	6075
6095DA	6095	6075
6100DA	6100	6075
6105DA	6105	6075
6120DA	6120	6075
6120DB	6120	6095
6125DA	6125	6075
6125DB	6125	6095
6130DA	6130	6075
6130DB	6130	6095
6130DC	6130	6105
6135DA	6135	6075
6135DB	6135	6095
6135DC	6135	6105
6140DA	6140	6075
6140DB	6140	6095
6140DC	6140	6105
6145DA	6145	6075
6145DB	6145	6095
6145DC	6145	6105
6160DA	6160	6095
6160DB	6160	6105
6160DC	6160	6125
6165DA	6165	6095
6165DB	6165	6105

**Reduction Ratio Combination**

Total Ratio	Second Stage Ratio	First Stage Ratio
104	13	8
121	11	11
143	13	11
165	15	11
195	15	13
231	21	11
273	21	13
319	29	11
377	29	13
473	43	11
559	43	13
649	59	11
731	43	17
841	29	29
1003	59	17
1247	43	29
1479	87	17
1849	43	43
2065	59	35
2537	59	43
3045	87	35
3481	59	59
4437	87	51
5133 <sup>[1]</sup>	87	59
6177	87	71
7569	87	87

Note: [1] For frame sizes 6205DA, DB or DC ~ 6265DA, DB or DC, second stage ratio is 59 and first stage ratio is 87.





# REDUCER LUBRICATION

## Standard Type Mounted Reducer (Slow Speed Shaft Horizontal)<sup>[1,2]</sup>

**Table B-3. Horizontal Mounted Single Reduction Reducers**

Reduction Ratio / Frame Size	3	5	6	8	11	13	15	17	21	25	29	35	43	51	59	71	87	119	
6060 6065	Grease Lubricated (G)																		
6070 6075																			
6080 6085																			
6090 6095																			
6100 6105 610H																			
6110 6115																			
6120 6125 612H	Oil Bath Lubrication (PB)																		
6130 6135																			
6140 6145 614H																			
6160 6165 616H																			
6170 6175																			
6180 6185																			
6190 6195																			
6205																			
6215																			
6225																			
6235																			
6245																			
6255																			
6265																			
6275																			

**Table B-4. Horizontal Mounted Double Reduction Reducers**

Reduction Ratio / Frame Size	104	121	143	165	195	231	273	319	377	473	559	649	731	841	1003	1015	1247	1479	1849	2065	2537	3045	3481	4437	5133	6177	7569																											
6060DA 6065DA	Maintenance-Free Grease Lubrication (MF)																																																					
6070DA 6075DA																																																						
6090DA 6095DA																																																						
6100DA 6105DA																																																						
6120DA 6120DB																																																						
6125DA 6125DB																																																						
6130DA 6135DA	Grease Lubrication (G)																																																					
6130DB 6135DB																																																						
6130DC 6135DC																																																						
6140DA 6140DB 6140DC																																																						
6145DA 6145DB 6145DC																																																						
6160DA 6165DA																																																						
6160DB 6165DB																																																						
6170DA 6175DA																																																						
6170DB 6175DB																																																						
6180DA 6185DA																																																						
6160DC 6165DC																												Oil Bath Lubrication (PB)																										
6170DC 6175DC																																																						
6180DB 6185DB																																																						
6190DA 6195DA																																																						
6190DB 6195DB																																																						
6205DA 6205DB																																																						
6215DA 6215DB																																																						
6225DA 6225DB																																																						
6235DA 6235DB																																																						
6245DA 6245DB																																																						
6255DA 6255DB																																																						
6265DA																																																						
6275DA																																																						

Notes: [1] Tables B-3 and B-4 show the standard lubrication method when the Cyclo drive is driven at the standard input speed.  
 [2] Ratios shown in white in Tables B-3 and B-4 are unavailable for the given unit sizes.

# REDUCER LUBRICATION

## Standard Vertical Mounted Reducer (Slow Speed Shaft Vertical)<sup>[1,2,3]</sup>

**Table B-5. Vertical Mounted Single Reduction Reducer**

Reduction Ratio	3	5	6	8	11	13	15	17	21	25	29	35	43	51	59	71	87	119		
Frame Size																				
6060 6065	Grease Lubricated (G)																			
6070 6075																				59
6080 6085																				87
6090 6095																				
6100 6105																				
6110 6115																				
6120 6125																				
6130 6135																				
6140 6145																				
6160 6165																				
6170 6175																				
6180 6185																				
6190 6195																				
6205																				
6215																				
6225																				
6235																				
6245																				
6255																				
6265																				
6275												TP		TP		TP		TP		

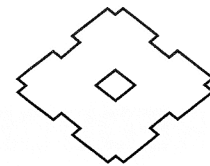
TP: Positive Displacement Pump Lubrication (see Table B-16.)

**Table B-6. Vertical Mounted Double Reduction Reducer**

Reduction Ratio	104	121	143	165	195	231	273	319	377	473	559	649	731	841	1003	1015	1247	1479	1849	2065	2537	3045	3481	4437	5133	6177	7569	
Frame Size																												
6060DA 6065DA	Maintenance-Free Grease Lubrication (MF)																											
6070DA 6075DA																												2537
6090DA 6095DA																												5133
6100DA 6105DA																												
6120DA 6120DB																												
6125DA 6125DB																												
6130DA 6135DA																												
6130DB 6135DB																												
6130DC 6135DC																												
6140DA 6140DB																												
6140DC																												
6145DA 6145DB																												
6145DC																												
6160DA 6165DA																												
6160DB 6165DB																												
6170DA 6175DA																												
6170DB 6175DB																												
6180DA 6185DA																												
6160DC 6165DC																												
6170DC 6175DC																												
6180DB 6185DB																												
6190DA 6195DA																												
6190DB 6195DB																												
6205DA 6205DB																												
6215DA 6215DB		121																										
6225DA 6225DB																												
6235DA 6235DB																												
6245DA 6245DB																												
6255DA 6255DB																												
6265DA																												
6275DA																												

TP: Positive Displacement Pump Lubrication (see Table B-16)

- Notes: [1] Please consult the factory for applications where the slow speed shaft is up.
- [2] Tables B-5 and B-6 show the standard lubrication method when the Cyclo drive is driven at the standard input speed.
- [3] Ratios shown in white in Tables B-5 and B-6 are unavailable for the given unit sizes.



# REDUCER LUBRICATION

## Lubricants

### Grease Lubricated Models

Those models listed in Tables B-3 ~ B-6 as grease lubricated are filled with grease before shipment to the customer and are ready for use.

**Table B-7. Standard Greases<sup>[1]</sup>**

Ambient Temperature <sup>[2]</sup>		Cyclo <sup>®</sup> Disc-Type	Cyclo <sup>®</sup> Planetary-Type
°F	°C		
14 to 122	-10 to 50	Exxon Unirex N2 Grease	Shell Gadus S2 V220 0 Grease

**Table B-8. Grease Replenishment and Change Interval**

Model	Condition	Interval <sup>[3]</sup>	
Single and Double Reduction Maintenance Free Type	Replenishment	NOT REQUIRED	
	Overhaul <sup>[4]</sup>	Every 20,000 Hours or Every 4 ~ 5 Years	
Double Reduction	Replenishment	Less Than 10 Hours Per Day Operation	Every 3 ~ 6 Months
		10 ~ 24 Hours Per Day Operation	Every 500 ~ 1000
	Change	Speed Reducer Mechanism, High Speed Shaft Bearings (Speed Reducer Type)	Every 2 ~ 3 Years
		Slow Speed Shaft Bearings	Every 3 ~ 5 Years

## Replenishment and Change Guidelines

Those units designated as maintenance free in Tables B-3 ~ B-6 do not require replenishment when supplied with standard greases. Certain optional greases do require replenishment. Those units will have a Zerk fitting either on the high speed endshield or near the input shaft bearing housing.

Replenish grease to the reduction mechanism with 1/3 to 1/2 of the quantity listed in Table B-9 or B-10 at the interval recommended in Table B-8. Remove the drain plug from gearbox output section. Replenish grease through the Zerk fitting. After inserting the recommended amount of grease run the unit for five or 10 minutes to circulate the grease and purge any excess. Replace the drain plug and return to service.

When the unit is disassembled for overhauling, refill with the grease quantities indicated in Table B-9 or B-10. Or alternatively, 80% of the space around the reduction mechanism and slow speed shaft

bearings of single reduction units, and 50% around the reduction mechanism of both the first and second stage of double reduction units.

Apply grease liberally to the central part (i.e., around the eccentric bearings) of the mechanism. Apply grease to both the slow speed and high speed shaft bearings as you would to ordinary bearings at the time or re-assembly.

If excessive grease is added, agitation heating of the grease will raise the operating temperature of the unit. Avoid excessive greasing, but do not supply an insufficient amount of grease. When the grease is insufficient, it will raise the unit's operating temperature due to breakdown of the lubrication films on the eccentric bearing. In this case, if the operating temperature rises, supply grease immediately.

**Table B-9. Single Reduction Grease Quantities<sup>[5]</sup> oz. (g.)**

Frame Size	6060 6065	6070 6075	6080 6085	6090 6095	6100 6105 610H	6110 6115	6120 6125 612H
Speed Reduction Mechanism	0.9 (25)		1.4 (40)	2.1 (60)	4.2 (120)	6.7 (190)	8.8 (250)
Slow Speed Shaft Bearing	0.5 (15)		0.9 (25)	1.1 (30)	1.1 (30)	1.6 (45)	1.9 (55)

Notes: [1] Avoid the use of grease other than shown in Table B-7. For Food-Grade Lubricants, see Appendix D-3.

[2] Consult the factory when the drives are used under widely fluctuating temperatures, ambient temperatures other than those listed in Table B-7, or any other special conditions.

[3] Single reduction frame sizes 6060 ~ 612H and double reduction frame sizes 6060DA ~ 6125DB are maintenance free units. Grease replenishment is not necessary. Where longer life of the drive is expected or if re-lubricating is preferred before the recommended interval, refer to Tables B-7, B-8, B-9 and B-10.

[4] Overhauling consists of disassembling the unit, replacing the seals and gaskets, cleaning the internal parts and then repacking the unit with designated grease.

[5] For non-standard grease units, refer to page Appendix D-2 for grease quantities

# REDUCER LUBRICATION

**Table B-10. Double Reduction Grease Quantities – oz. (g.)**

Frame Size	6060DA 6065DA	6070DA 6075DA	6090DA 6095DA	6100DA 6105DA	6120DA 6125DA	6120DB 6125DB	6130DA 6135DA	6130DB 6135DB	6130DC 6135DC	6140DA 6145DA	6140DB 6145DB	6140DC 6145DC
Speed Reduction Mechanism (1st stage)	0.9 (25)					2.1 (60)	0.9 (25)	2.1 (60)		0.9 (25)	2.1 (60)	4.2 (120)
Speed Reduction Mechanism (2nd stage)	0.9 (25)		2.1 (60)	4.2 (120)	8.8 (250)		15.9 (450)					
Slow Speed Shaft Bearing (2nd stage)	0.5 (15)	0.5 (15)	1.1 (30)	1.1 (30)	1.9 (55)		10.6 (300)					

Frame Size	6160DA 6165DA	6160DB 6165DB	6160DC 6165DC	6170DA 6175DA	6170DB 6175DB	6170DC 6175DC	6180DA 6185DA	6180DB 6185DB	6190DA 6195DA	6190DB 6195DB	6205DA	6205DB
Speed Reduction Mechanism (1st stage)	2.1 (60)	4.2 (120)	8.8 (250)	2.1 (60)	4.2 (120)	8.8 (250)	4.2 (120)	15.9 (450)	11.6 (330)	15.9 (450)	11.6 (330)	15.9 (450)
Speed Reduction Mechanism (2nd stage)	26.5 (750)			35.3 (1000)			38.8 (1100)		52.9 (1500)			
Slow Speed Shaft Bearing (2nd stage)	10.6 (300)			17.6 (500)			21.2 (600)		24.7 (700)			

Frame Size	6215DA	6215DB	6225DA	6225DB	6235DA	6235DB	6245DA	6245DB	6255DA	6255DB	6265DA
Speed Reduction Mechanism (1st stage)	15.9 (450)	26.5 (750)	15.9 (450)	35.3 (1000)	26.5 (750)	35.3 (1000)	26.5 (750)	38.8 (1100)	35.3 (1000)	52.9 (1500)	52.9 (1500)
Speed Reduction Mechanism (2nd stage)	70.5 (2000)		88.2 (2500)		141.1 (4000)		158.7 (4500)		211.6 (6000)		282.2 (8000)
Slow Speed Shaft Bearing (2nd stage)	28.2 (800)		31.7 (900)		35.3 (1000)		38.8 (1100)		42.3 (1200)		45.9 (1300)

## Oil Lubricated Models

### Oil Fill Procedure

Oil lubricated models **are not** filled with oil prior to shipping. Before start-up, remove the oil fill plug (See Pg. B-3, Fig. B-2, Part #28) and fill the reducer with recommended oil. Refer to Tables B-11 ~ B-14 for standard oil, allowable viscosity, quantity, and change interval. The oil level must be to the upper red line on the oil level gauge while the unit is not operating, and above the lower red line during operation. If too much oil is supplied, the unit's operating temperature will rise due to the churning heat of the oil, or oil will leak across the high speed shaft oil seal.

Before filling a vertical base type unit with oil, remove the vent plug (Pg. B-3, Fig. B-2, Part #14). After filling, apply teflon sealing tape to threads of the vent plug before installing.

When draining oil, remove drain plug (Fig. B-5, Part #46) or lower side plug of the oil level gauge.

### Oil Level Gauge

The gauge must be replaced when it becomes difficult to check the oil level due to discoloration of the vinyl hose. Use the standard vinyl oil gauge for a reducer operating in ambient temperature  $-4^{\circ}\text{F}$  to  $100^{\circ}\text{F}$  ( $-20^{\circ}\text{C}$  to  $40^{\circ}\text{C}$ ). Where the reducer is used at ambient temperatures greater than  $100^{\circ}\text{F}$  ( $40^{\circ}\text{C}$ ) or less than  $-4^{\circ}\text{F}$  ( $-20^{\circ}\text{C}$ ), a glass gauge set or a dipstick is recommended.

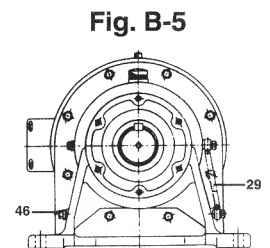
The oil level gauge can be attached on either side of the casing on horizontal units. Attach on the side that is most convenient for checking the oil level. (The oil level gauge is usually attached on the right side when viewed from the slow speed shaft end.)

Planetary-type units use the same oil as that of a Disc-type unit. The grease type differs between Planetary-type units and Disc-type units. Planetary units use Gadus S2 V220 0 grease, while Disc units use standard Unirex N2 grease.

**Table B-11. Approved Oils** <sup>[3]</sup> Oil lubricated reducers must be filled with oil prior to operation. Fill the reducer to the correct level with the recommended oil.

<b>ExxonMobil</b>	Spartan EP	<b>Idemitsu</b>	Daphne Super Gear Oil	<b>BP</b>	Energol GR-XP	<b>Total</b>	Carter EP
<b>Mobil</b>	Mobilgear 600XP	<b>Kluber</b>	Kluberoil GEM1	<b>Castrol</b>	Alpha SP		
<b>Shell</b>	Omala S2 G	<b>Caltex</b>	Meropa	<b>Gulf</b>	EP Lubricant HD		

Ambient Temperature	
<b>°F</b>	14      32      50      68      86      104      122
<b>°C</b>	-10      0      10      20      30      40      50
<b>ISO VG</b>	68
	100 / 150
	220 / 320 / 460

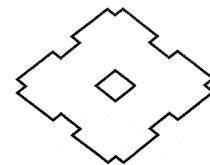


Notes: [1] Use the lower viscosity oil specified for each ambient temperature range for use in winter or relatively low ambient temperatures.

[2] Please consult the factory for consistent use in ambient temperatures other than  $32^{\circ}\text{F}$  -  $104^{\circ}\text{F}$  ( $0^{\circ}\text{C}$  -  $40^{\circ}\text{C}$ ).

[3] For Food-Grade Lubricants, see Appendix D-3.

[4] For approved Synthetic Oils, minimum AGMA Service Factor should be 1.4.



**Table B-12. Oil Fill Quantities<sup>[1]</sup>**

Single Reduction					Double Reduction				
Frame Size	Mounting Configuration				Frame Size	Mounting Configuration			
	Horizontal		Vertical			Horizontal		Vertical	
	U.S. gal.	liter	U.S. gal.	liter		U.S. gal.	liter	U.S. gal.	liter
6130, 6135	0.18	0.7	0.29	1.1	6160DC, 6165DC	0.40	1.5	0.26	1.0
6140, 6145, 614H	0.18	0.7	0.29	1.1	6170DC, 6175DC	0.63	2.4	0.50	1.9
6160, 6165, 616H	0.37	1.4	0.26	1.0	6180DB, 6185DB	0.92	3.5	0.53	2.0
6170, 6175	0.50	1.9	0.50	1.9	6190DA, 6195DA	1.5	5.8	0.71	2.7
6180, 6185	0.66	2.5	0.53	2.0	6190DB, 6195DB	1.6	6.0	0.71	2.7
6190, 6195	1.1	4.0	0.71	2.7	6205DA, 6205DB	1.6	6.0	2.9	11
6205	1.5	5.5	1.5	5.7	6215DA, 6215DB	2.6	10	3.7	14
6215	2.2	8.5	2.0	7.5	6225DA, 6225DB	2.9	11	4.8	18
6225	2.6	10	2.6	10	6235DA, 6235DB	4.5	17	6.1	23
6235	4.0	15	3.2	12	6245DA, 6245DB	4.8	18	7.7	29
6245	4.2	16	4.0	15	6255DA, 6255DB	6.1	23	11.1	42
6255	5.5	21	11.1	42	6265DA	8.5	32	13.5	51
6265	7.7	29	13.5	51	6275DA	15.9	60	(15.9)	(60)
6275	14.8	56	(15.9)	(60)					

( ) with trochoid pump

**Table B-13. Allowable Oil Viscosity**

Minimum Allowable Viscosity To Maintain Lubricating Oil Film		80 SUS During Operation	
Maximum Allowable Viscosity To Allow Easy Starting	Oil Bath	20,000 SUS At Operation Start	
	Forced Oil Lubrication	10,000 SUS At Operation Start	

**Table B-14. Oil Change Interval**

Oil Change Interval		Operation Condition
Initial Oil Change	After 500 Hours of Primary Operation	Under Every Condition
Subsequent Oil Change	Every 6 Months	Less Than 10 Hours/Day Operation
	Every 2,500 Hours	10 ~ 24 Hours/Day Operation
	Every 1 ~ 3 Months	High Ambient Temperature, High Humidity or Atmosphere of Active Gas

**Forced Lubrication For Vertical Units**

**Table B-15. Plunger Pump Type**

Small Size Pump		Large Size Pump	
Frame Size	Ratio	Frame Size	Ratio
6160, 6165, 6170, 6175, 6180, 6185, 6190, 6195	See Table B-5	6205, 6215, 6225, 6235, 6245, 6255, 6265, 6275	See Table B-5
6160DC, 6165DC, 6170DC, 6175DC, 6180DB, 6185DB, 6190DA, 6195DA, 6190DB, 6195DB	See Table B-6	6205DA, 6205DB, 6215DA, 6215DB, 6225DA, 6225DB, 6235DA, 6235DB, 6245DA, 6245DB, 6255DA, 6255DB, 6265DA	See Table B-6

**Plunger Pump Lubrication**

The plunger pump (Fig. B-2, Part #42) is automatically operated by a cam (Fig. B-2, Part #40) fitted on the slow speed shaft (Fig. B-2, Part #1-01). The number of pumping cam teeth required is in direct relation to the reduction ratio and frame size. Please consult the factory for input speeds other than standard.

**Table A-16. Positive Displacement (Trochoid) Pump Type**

Cyclo Drive			Trochoid Pump <sup>[2,3]</sup>									
Type	Frame Size	Reduction Ratio	Pump Type	Pump Motor	50 Hz Zone				60 Hz Zone			
					Flow		Max. Pressure		Flow		Max. Pressure	
					gal/min	l/min	psi	kgf/cm <sup>2</sup>	gal/min	l/min	psi	kgf/cm <sup>2</sup>
Vertical Shaft	6275	29, 43, 59, 87	TOP216HA-VB3	1 HP (0.75 kW) 4P	6.3	24.0	113.8	8	7.6	28.8	71.1	5.0
	6275DA	All	TOP204HA-VB3	1/2 HP (0.4 kW) 4P	1.6	6.0	227.6	16	1.9	7.2	163.6	11.5

**Positive Displacement (Trochoid) Pump Lubrication**

Forced oil lubrication is accomplished by using a positive displacement pump and motor that requires an additional electric power source. It is recommended that the main

motor be interlocked with the pump motor to avoid operation without lubrication. The pump must be started 30 seconds or longer before the main motor is operated.

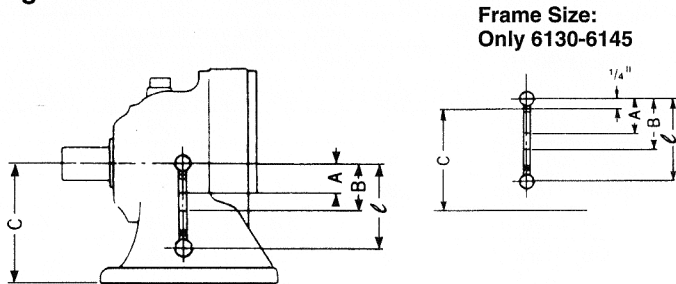
Notes: [1] Please consult the factory for oil quantities when the reducer/gearmotor is mounted in any other position or angle.

[2] Consult the factory when using an inverter.

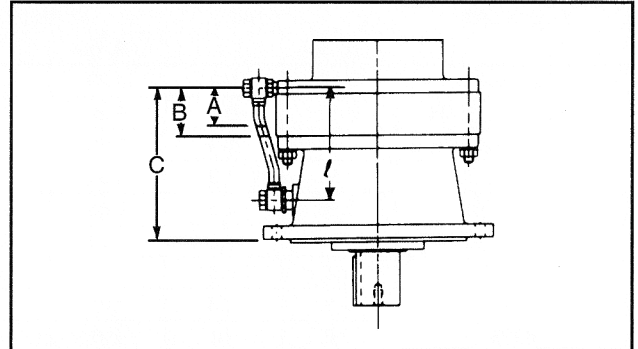
[3] A relief valve, pressure set at 42.7 psi (3 kgf/cm<sup>2</sup>), is a standard attachment on the trochoid pump.

# REDUCER OIL LEVEL DIMENSIONS

**Foot Mount Horizontal Type**  
Fig. B-6



**Base Mount Vertical Type**  
Frame Size: 6130 ~ 614H  
Fig. B-7



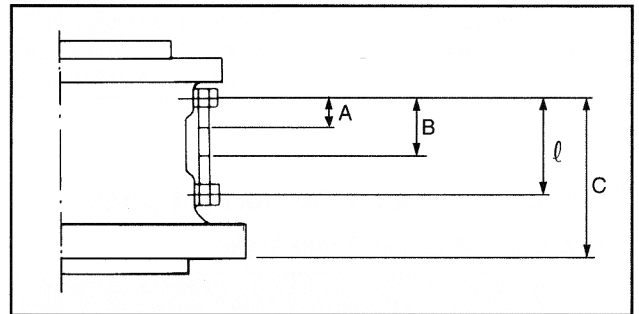
**Table B-17. Oil Level Dimensions (Inches)**

Frame Size	A	B	C	ℓ
6130-6135	1.38	2.17	5.91	4.65
6140-6145, (614H)	1.38	2.17	5.91 (6.30)	4.65
6160-6165, (616H)	1.57	2.76	6.30 (7.87)	3.70
6160DC-6165DC	1.18	1.77	6.30	3.70
6170-6175	1.97	3.35	7.87	4.96
6170DC-6175DC	1.18	1.77	7.87	4.96
6180-6185	2.17	3.94	8.66	5.91
6180DB-6185DB	1.38	2.17	8.66	5.91
6190-6195	2.26	3.25	9.84	6.61
6190DA-6195DA	1.18	1.77	9.84	6.61
6190DB-6195DB	1.38	2.18	9.84	6.61
6205	2.12	3.19	9.84	6.06
6205DA	1.26	1.93	9.84	6.06
6205DB	1.26	2.13	9.84	6.06
6215	2.05	3.03	10.84	6.85
6215DA	1.18	1.97	10.43	6.85
6215DB	1.57	2.76	10.43	6.85
6225	2.25	3.43	11.03	6.85
6225DA	1.26	2.05	11.03	6.85
6225DB	1.85	3.43	11.03	6.85
6235	2.48	3.47	11.81	7.64
6235DA	1.57	2.75	11.81	7.64
6235DB	1.97	3.35	11.81	7.64
6245	2.76	3.78	13.19	8.46
6245DA	1.65	2.72	13.19	8.46
6245DB	2.00	3.35	13.19	8.46
6255	3.19	4.17	14.76	9.02
6255DA	1.97	3.35	14.76	9.02
6255DB	2.05	3.23	14.76	9.02
6265	3.23	4.21	15.75	10.16
6265DA	2.28	3.27	15.75	10.16
6275	3.35	4.53	21.26	11.22
6275DA	2.26	3.25	21.26	11.22

**Base Mount Vertical Type**  
Table B-18. Oil Level Dimensions (Inches)  
Frame Size: 6130 ~ 614H

Frame Size	A	B	C	ℓ
6130-614H	1.85	2.72	7.52	5.79

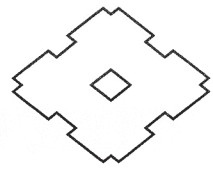
**Base Mount Vertical Type**  
Frame Size: 6160 ~ 6275  
Fig. B-8



**Base Mount Vertical Type**  
Table B-19. Oil Level Dimensions (Inches)  
Frame Size: 6160 ~ 6275

Frame Size	A	B	C	ℓ
6160-6165, 616H	1.02	1.42	4.68	2.72
6170-6175	1.69	2.48	6.02	3.78
6180-6185	1.93	2.72	6.81	4.25
6190-6195	2.09	3.27	7.87	5.47
6205	1.46	2.05	7.09	3.54
6215	1.46	2.05	7.09	3.54
6225	1.46	2.05	7.87	3.54
6235	1.46	2.05	7.72	3.54
6245	1.46	2.05	7.96	3.54
*6255	4.33	4.92	19.76	6.57
*6265	4.65	5.24	21.69	7.17
6275	1.97	2.76	13.39	5.51

\*Note: V6255 & V6265 Oil Gauge is on the Ring Gear Housing instead of V-Casing.



# REDUCER BEARINGS, OIL SEALS, GASKETS

Fig. B-9

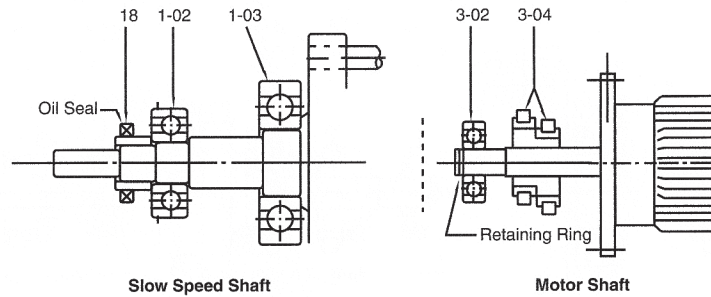


Table B-20. Slow Speed Shaft Bearing

Frame Size		Slow Speed Shaft	
Single Reduction	Double Reduction	Bearing A Part #1-02	Bearing B Part #1-03
6060, 6065	6060DA, 6065DA	6204Z	6909
6070, 6075	6070DA, 6075DA	6204Z	6909
6080, 6085	-	6305Z	6009
6090, 6095	6090DA, 6095DA	6306Z	16011
6100, 6105, 610H	6100DA, 6105DA	6306Z	16011
6110, 6115	-	6307Z	6011
6120, 6125, 612H	6120DA, 6125DA, 6120DB, 6125DB	6308Z	6013
6130, 6135	6130DA, 6135DA, 6130DB, 6135DB, 6130DC, 6135DC	6211NR	6213
6140, 6145, 614H	6140DA, 6145DA, 6140DB, 6145DB, 6140DC, 6145DC	22211EXNR	6213
6160, 6165	6160DA, 6165DA, 6160DB, 6165DB, 6160DC, 6165DC	3TM-6213NR <sup>[1]</sup>	6215 <sup>[1]</sup>
6170, 6175	6170DA, 6175DA, 6170DB, 6175DB, 6170DC, 6175DC	6216NR <sup>[1]</sup>	6218 <sup>[1]</sup>
6180, 6185	6180DA, 6185DA, 6180DB, 6185DB	6218NR <sup>[1]</sup>	6220 <sup>[1]</sup>
6190, 6195	6190DA, 6195DA, 6190DB, 6195DB	6221NR <sup>[1]</sup>	6026 <sup>[1]</sup>
6205	6205DA, 6205DB	22220BNRC2	6222C2
6215	6215DA, 6215DB	23022BNRC2	6224C2
6225	6225DA, 6225DB	23024BNRC2	6226C2
6235	6235DA, 6235DB	23026BNRC2	NUP228C2
6245	6245DA, 6245DB	23028BNRC2	NUP230C2
6255	6255DA, 6255DB	23032BNRC2	NUP234C2
6265	6265DA	23034BNRC2	NUP236C2
6275	6275DA	23136BNXR	6340

Table B-21. Motor Shaft Bearing

Frame Size		High Speed Shaft		
Single Reduction	Double Reduction	Bearing C Part #3-02	Eccentric Part #3-04	Qty.
6060, 6065	6060DA, 6065DA, 6070DA, 6075DA	6301	607YXX	1
6070, 6075	6090DA, 6095DA, 6100DA, 6105DA, 6120DA, 6125DA, 6130DA, 6135DA, 6140DA, 6145DA	6301	607YXX	1
6080, 6085	-	6301SH	6004RSH2ZZC3	1
6090, 6095	6120DB, 6125DB, 6130DB, 6135DB, 6140DB, 6145DB, 6160DA, 6165DA, 6170DA, 6175DA	6302RSH2	Refer to Table B-22	1
6100, 6105, 610H	6130DC, 6135DC, 6140DC, 6145DC, 6160DB, 6165DB, 6170DB, 6175DB, 6180DA, 6185DA	6302RSH2		
6110, 6115	-	6302RSH2	611YSS, 611GSS	2
6120, 6125, 612H	6160DC, 6165DC, 6170DC, 6175DC, 6190DA, 6195DA, 6205DA	<b>Bearing 3-02 is not used in these unit sizes</b>	Refer to Table B-22	1
6130, 6135	6180DB, 6185DB, 6190DB, 6195DB, 6205DB, 6215DA, 6225DA			
6140, 6145, 614H	-			
6160, 6165, 616H	6215DB, 6235DA, 6245DA			
6170, 6175	6255DA, 6255DB			
6180, 6185	6235DB, 6245DB			
6190, 6195	6255DB, 6265DA, 6275DA			
6205	-			
6215	-			
6225	-			
6235	-			
6245	-			
6255	-			
6265	-			
6275	-			
			617YSX	2
			618YSX	2
			619YSX	2
			620GXX	2
			621GXX	2
			622GXX	2
			623GXX	2
			624GXX	2
			625GXX	2
			626GXX	2
			627GXX	2

Note: [1] For grease lubricated models, a sealed bearing should be used, which changes the following letters in the part number to those shown in bold: NR (Std.) – **ZNR**; NXR – **ZNXR**; None – add **Z**.

# REDUCER BEARINGS, OIL SEALS, GASKETS

Fig. B-10

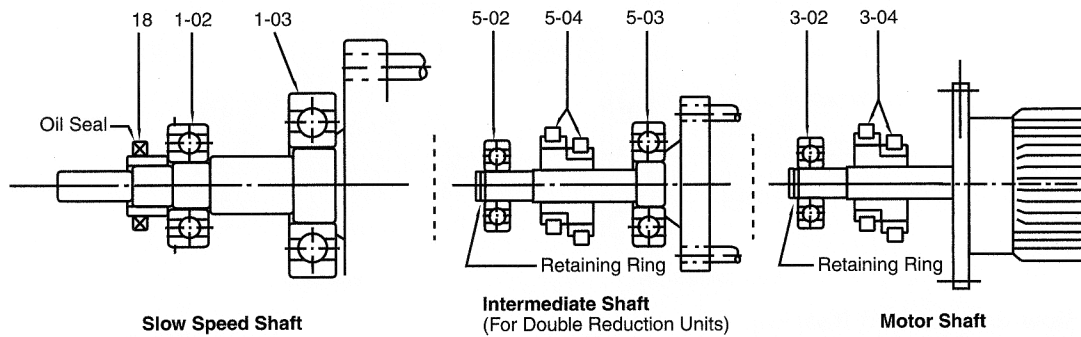
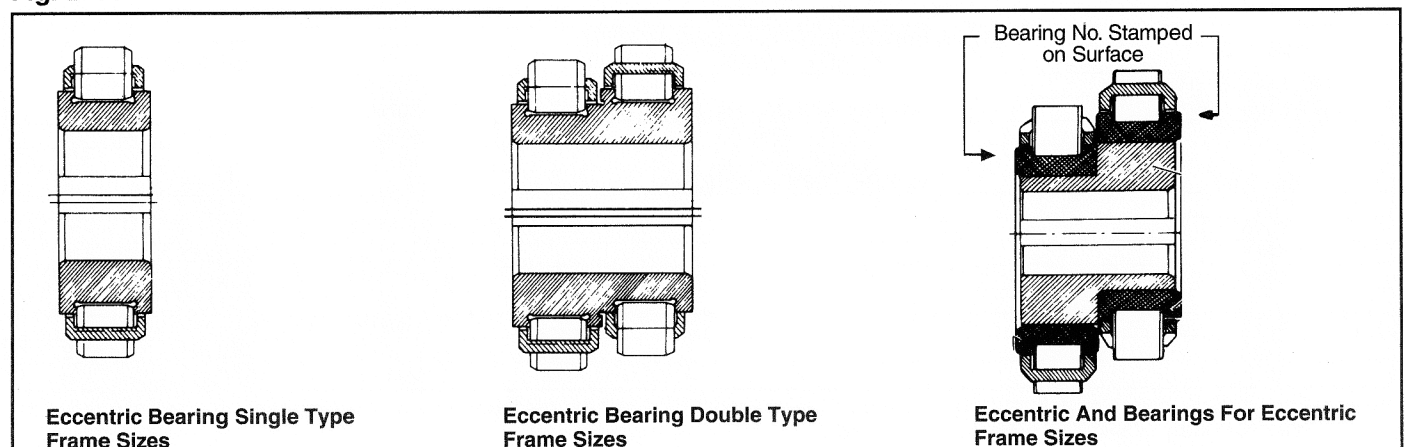


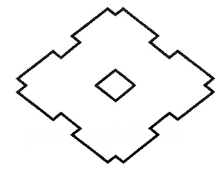
Table B-22. Eccentric Bearing

High Speed Shaft, Motor Shaft Part #3-04	Frame Size					
	6090, 6095	6100, 6105	6120, 6125	6130, 6135	6140, 6145	6160, 6165
Intermediate Shaft Part #5-04	6090DA 6095DA	6100DA 6105DA	6120DA, 6125DA 6120DB, 6125DB	6130DA, 6135DA 6130DB, 6135DB 6130DC, 6135DC	6140DA, 6145DA 6140DB, 6145DB 6140DC, 6145DC	6160DA, 6165DA 6160DB, 6165DB 6160DC, 6165DC
Reduction Ratio						
6	60906YRX	6100608YRX	6120608YRX	61406-11YSX	61406-11YSX	6160608YRX2
8	60908-15YSX	6100608YRX	6120608YRX	61406-11YSX	61406-11YSX	6160608YRX2
11	60908-15YSX	61011-15YRX	6121115YSX	61406-11YSX	61406-11YSX	61611-15YSX
13	60908-15YSX	61011-15YRX	6121317YSX	61413-17YSX	61413-17YSX	61611-15YSX
15	60908-15YSX	61011-15YRX	6121115YSX	61413-17YSX	61413-17YSX	61611-15YSX
17	60917YSX	61017YSX	6121317YSX	61413-17YSX	61413-17YSX	61617-25YSX
21	60921YSX	61021YRX	61221YRX	6142125YSX	6142125YSX	61617-25YSX
25	6092529YSX	6102529YRX	6122529YSX	6142125YSX	6142125YSX	61617-25YSX
29	6092529YSX	6102529YRX	6122529YSX	6142935YSX	6142935YSX	6162935YSX
35	60935YSX	61035YRX	61235YRX	6142935YSX	6142935YSX	6162935YSX
43	60943YSX	61043YSX	61243YSX	61443-59YSX	61443-59YSX	6164351YSX
51	60951YRX	61051YRX	6125159YSX	61443-59YSX	61443-59YSX	6164351YSX
59	60959YSX	61059YRX	6125159YSX	61443-59YSX	61443-59YSX	61659YSX
71	60971YRX	61071YRX	6127187YSX	6147187YSX	6147187YSX	61671YRX2
87	60987YSX	61087YRX	6127187YSX	6147187YSX	6147187YSX	61687YSX
119	609119YSX	610119YSX	-	-	-	-

Fig. B-11







**Table B-23. Intermediate Shaft Bearing**

Frame Size	Intermediate Shaft				Frame Size	Intermediate Shaft			
	Bearing F Part #5-02	Bearing G Part #5-03	Eccentric Bearing Part #5-04	Qty.		Bearing F Part #5-02	Bearing G Part #5-03	Eccentric Bearing Part #5-04	Qty.
6060DA, 6065DA	6301	6909	607YXX	1	6180DA, 6185DA	6407	6208	618YSX	2
6070DA, 6075DA	6301	6909	607YXX	1	6180DB, 6185DB	6407	6213	618YSX	2
6090DA, 6095DA	6302RSH2	6007	Refer to Table B-22	1	6190DA, 6195DA	6408	6210	619YSX	2
6100DA, 6105DA	6302RSH2	6007			6190DB, 6195DB	6408	6213	619YSX	2
6120DA, 6125DA	6304	6007			6205DA	NJ310EV7	6210	620GXX	2
6120DB, 6125DB	6304	6205			6205DB	NJ310EV7	6310	620GXX	2
6130DA, 6135DA	6305	6007			6215DA, 6215DB	NJ311EV16	6311	621GXX	2
6130DB, 6135DB	6305	6206			6225DA, 6225DB	NJ312EV11	6313	622GXX	2
6130DC, 6135DC	6305	6206			6235DA, 6235DB	NJ313EV11	6314	623GXX	2
6140DA, 6145DA	6305	6007			6245DA	NJ314EV7	6315	624GXX	2
6140DB, 6145DB	6305	6206			6245DB	NJ314EV7	6316	624GXX	2
6140DC, 6145DC	6305	6206			6255DA, 6255DB	NJ316EV1	6318	625GXX	2
6160DA, 6165DA	6307R	6207			6265DA	NJ317EV1	6320	626GXX	2
6160DB, 6165DB					6275DA	NJ417	22220RH	627GXX	2
6160DC, 6165DC	6307R	6208							
6170DA, 6175DA	6406	6207			617YSX	2			
6170DB, 6175DB									
6170DC, 6175DC					617YSX	2			

**Table B-24. Oil Seals**

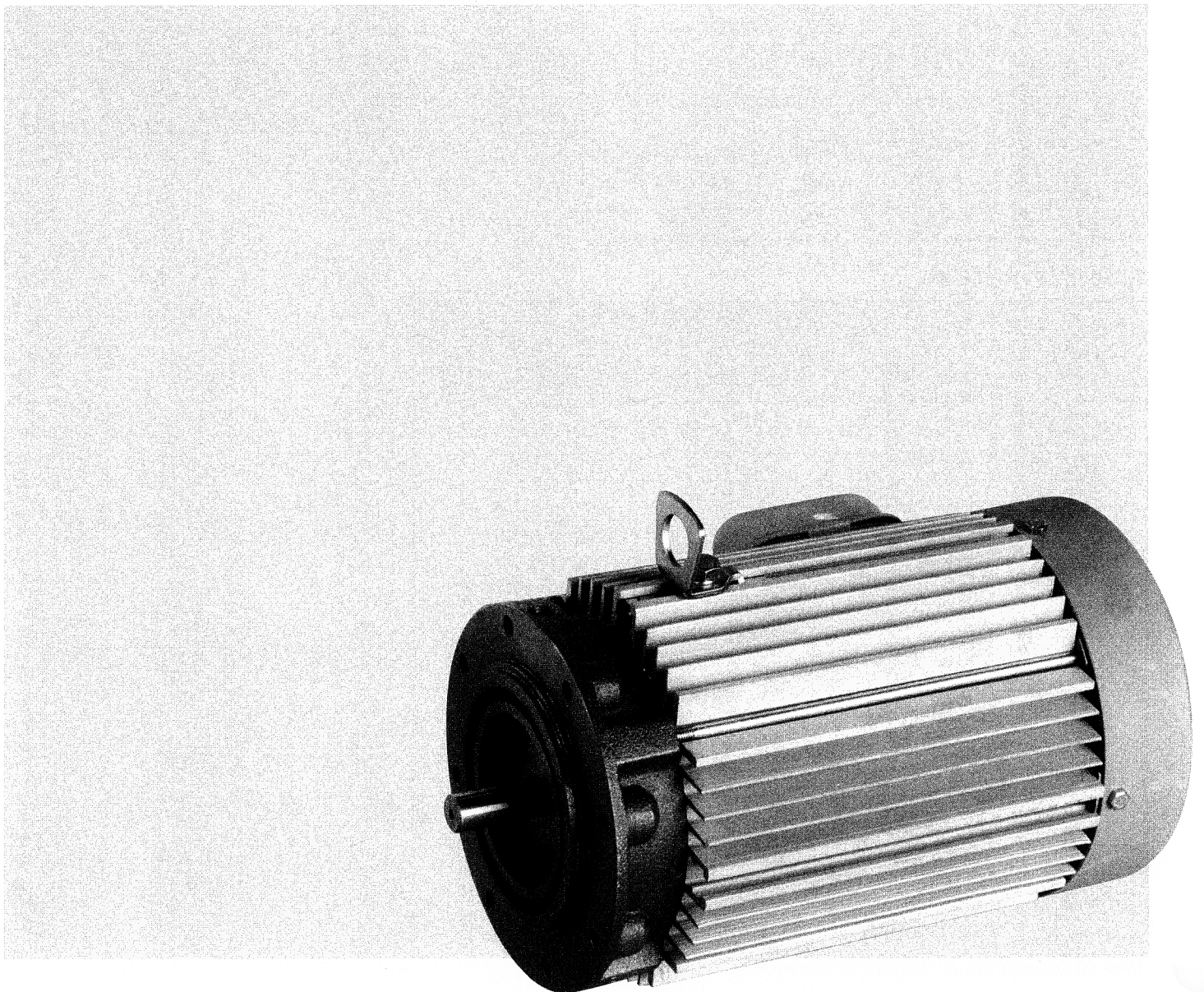
Frame Size	Slow Speed Shaft Part #18			
	Type <sup>[1]</sup>	Dimension (mm)	Quantity	
		(I.D. x O.D. x W)	Horizontal Shaft	Vertical Shaft
6060, 6065	D	30 x 47 x 8	1	1
6070, 6075	D	30 x 47 x 8	1	1
6080, 6085	D	45 x 62 x 9	1	1
6090, 6095	D	50 x 72 x 12	1	1
6100, 6105	D	50 x 72 x 12	1	1
6110, 6115	D	55 x 80 x 12	1	1
6120, 6125	D	65 x 90 x 13	1	1
6130, 6135	D	68 x 88 x 12	1	2
6140, 6145	D	65 x 88 x 12	1	2
6160, 6165	D	85 x 110 x 13	1	2
6170, 6175	D	95 x 130 x 15	1	2
6180, 6185	D	110 x 145 x 15	1	2
6190, 6195	D	120 x 155 x 16	1	2
6205	D	120 x 155 x 16	1	2
6215	D	130 x 160 x 14	1	2
6225	D	145 x 175 x 14	1	2
6235	D	160 x 190 x 16	1	2
6245	D	170 x 200 x 16	1	2
6255	D	190 x 225 x 16	1	2
6265	D	200 x 240 x 20	1	2
6275	D	230 x 270 x 20	1	2

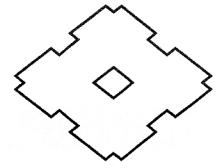
Note: [1] D indicates lip (dust proof and seal lip) type.

---

# ELECTRIC MOTOR

Sumitomo Heavy Industries Electrical Division has been manufacturing its various types of motors since 1913. The motor used with the SM-Cyclo® Gearmotor has been manufactured since 1969 with over 6 million shipped throughout the world.





# GENERAL CONSTRUCTION OF MOTOR

Fig. B-12 Motor construction

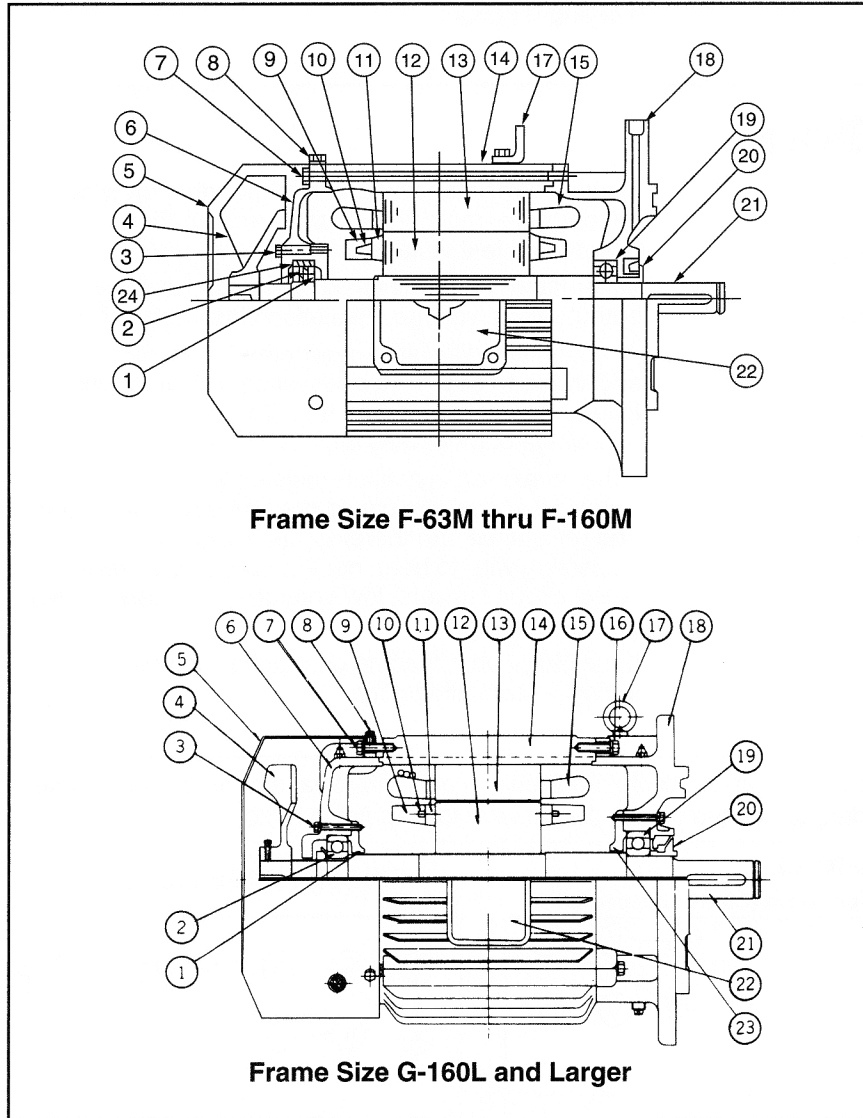


Table B-25. Main Parts  
Part No. Part Name

1	Bearing Cover**
2	Bearing
3	Bolt**
4	Fan*
5	Fan Cover
6	End Bracket
7	Bolt
8	Bolt
9	Internal Fan
10	Hub
11	Short Circuit Ring
12	Rotor Core
13	Stationary Core
14	Stator Frame
15	Stator Winding
16	Bolt
17	Eye Bolt
18	Cyclo Flange Bracket
19	Bearing
20	Slinger/Oil Seal
21	Motor Shaft
22	Conduit Box
23	Bearing Cover
24	Bearing Sleeve

\*No Fan 1/8 H.P., F-63S frame.

\*\*No bearing cover and bolt for frame sizes F-63S ~ F-132S.

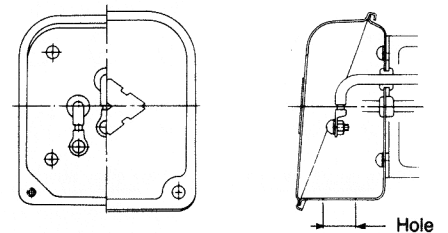


Fig. B-13 Conduit Box-Standard Type

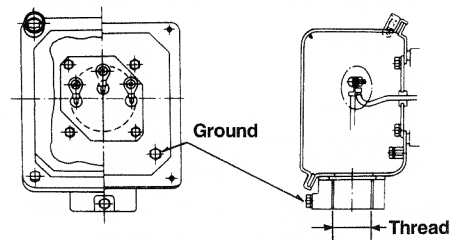


Fig. B-14 Weather-Proof Type

# GENERAL INSPECTION OF MOTOR

The following items should be verified when the motor is received:

1. Check the nameplate horsepower rating (H.P.), number of poles (P), type, voltage (volt) and frequency (Hz).

2. Rotate the motor shaft by hand to check for binding.

3. Check the motor's overall appearance for possible shipping damage.

## Pre-Start Up Inspection

Check the following prior to start-up:

1. **Wiring:** Prior to wiring, refer to the name plate affixed to the motor portion of the gearmotor. Check power supply, interconnects, relays protective starting devices, [i.e., Star (Wye) delta — if reduced voltage starting is required], space heaters, thermal sensors and other accessories.

2. **Grounding: Caution:** The motor frame and conduit box must be properly grounded so as to avoid electrical shock.

3. **Insulation Resistance:** Stator winding measurements are to be made at the motor terminals. Stator windings of less than 600 volts are to be measured with a 500 volts megger.

Insulation resistance will vary depending on winding temperature, moisture, cleanliness, duration of usage, and test voltage and charging period.

Other factors that will affect insulation resistance are: output rating, voltage, insulation class and RPM.

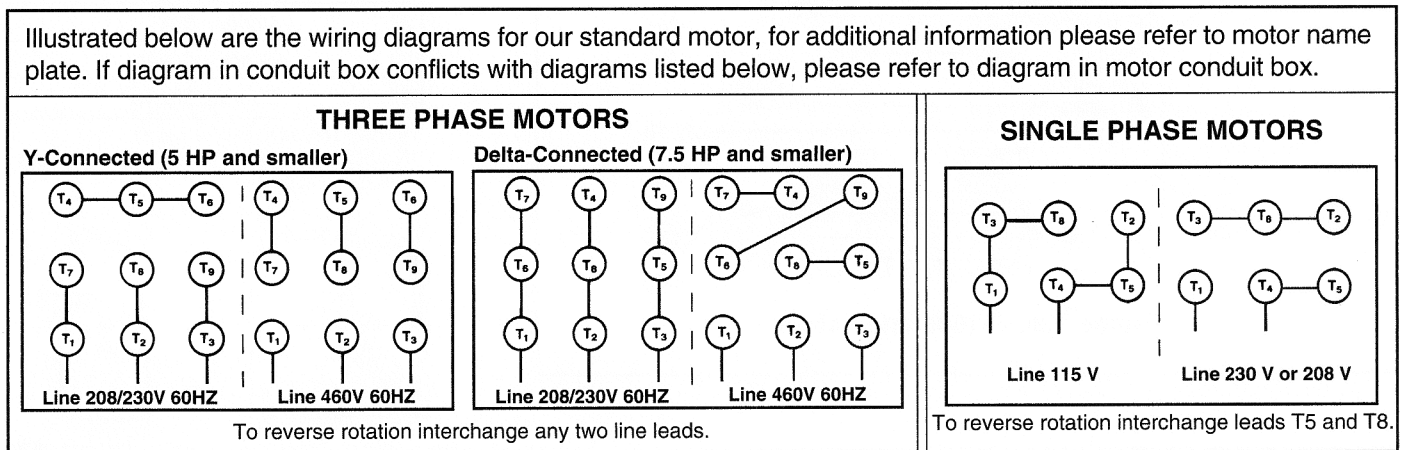
Although it is difficult to determine a minimum value applicable to each and every case, for simplicity the following may be used as a guide:

1 Mega ohm for less than 600 volts

If the measured insulation resistance is less than indicated above, the cause may be due to moisture. The resistance can therefore be increased by subjecting wire to heat, hot air, vacuum, current (short circuit current, low voltage — no load current, or direct current).

If the Mega ohm reading cannot be recovered by drying — consult factory.

Fig. B-15 Typical Wiring Diagrams



## Preparation and Start-up

Prior to start-up, please check the following under no load:

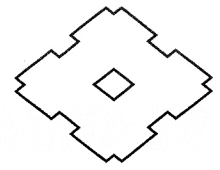
1. The driven load and the SM-Cyclo gearmotor are properly secured prior to operation.
2. The motor bearings are grease packed when shipped from our factory, however, if the motor is operated after long term storage, you must replenish the grease in the open type bearing only. Please refer to page B-17, Table B-27 for correct quantity.
3. Check the direction of rotation. If a reverse direction is

required, simply reverse any two power leads.

4. Check the voltage supply and current (line and phase) to verify balancing for a 3 phase power source.

5. When power is supplied to the motor and the starting is abnormally long, starting is not completed, or any abnormal sound is heard — immediately shut off the power and consult factory.

6. Measure the current draw. The current measured at full load should not exceed the nameplate rating.



# BEARINGS, OIL SEALS FOR MOTOR

## Non-Contact Shield Type Ball Bearings

These bearings do not require grease replenishment, however, it is recommended that they be replaced once every three years when operated under normal conditions, and once a year under severe duty conditions.

## Open Type Ball or Roller Bearing

For interval of grease replenishment, quantities of grease and the type of grease for the open type bearing refer to Tables B-26 and B-27.

**Table B-26. Type of Grease for Open Type Bearings**

Class of Insulation	Grease
B	Shell Alvania No. 2
H, F	Shell Darina No. 2

**Table B-27.**

## Interval and Quantity of Grease Replenishment

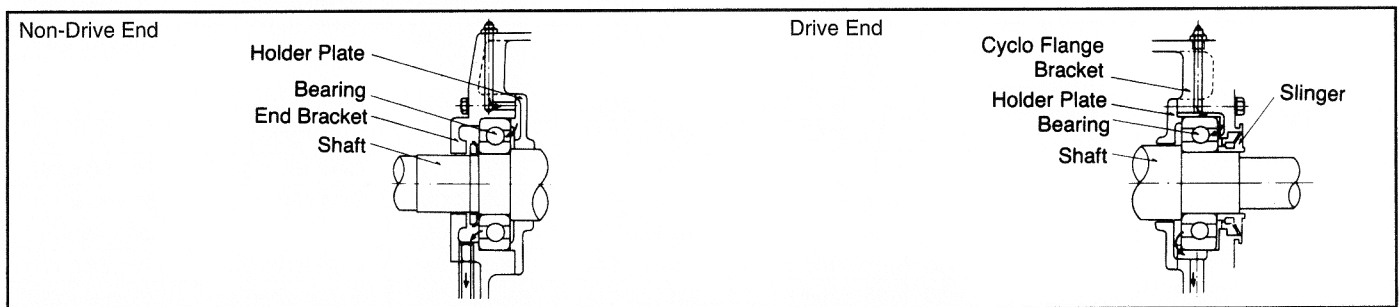
Bearing Size	Replenishment Qty (oz)	Initial Qty (oz)	Interval of Replenishment (HR)		
			900 rpm	1200 rpm	1800 rpm
6314	1.4	7.1	7000	5000	2500
6315	1.6	8.1	6500	4500	2500
6316	1.8	9.2	6500	4500	2500
6317	1.9	10	6000	4000	2000
6318	2.1	12	5500	4000	2000
6319	2.3	14	5500	3500	1500
6320	2.5	16	5000	3500	1500
6321	2.6	18	5000	3000	1500
6322	2.8	19	4500	3000	1000
6324	3.5	25	4000	2500	1000
6412	1.4	7.1	7000	5000	3000
6413	1.6	8.1	6500	4500	2500
6414	1.9	10	6500	4500	2500
NU314	1.4	4.2	3500	2500	—
NU315	1.6	5.3	3000	2000	—
NU316	1.8	7.1	3000	2000	—
NU317	1.9	8.8	3000	2000	—
NU318	2.1	10	2500	2000	—
NU319	2.3	12	2500	1500	—
NU320	2.5	14	2500	1500	—
NU321	2.6	16	2500	1500	—
NU322	2.8	18	2000	1500	—
NU324	3.5	23	2000	1000	—

## Grease Replenishment Procedure

The gearmotor must be running with the drain plug removed. Using a grease gun, inject a quantity of grease until some grease is purged from the drain. Plug the drain approximately 10 minutes after start of operation.

**Note:** Excess grease replenishment may cause overheating or leakage. A lack of grease will cause premature failure.

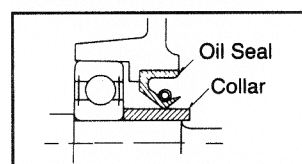
**Fig. B-16 Typical Bearing Assembly**



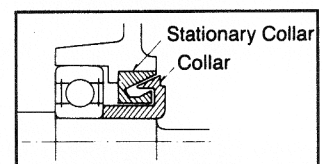
## Oil Seal

The reducer and the motor of the SM-CYCLO® Gear motor are integrally assembled. In grease lubricated units, a single lip seal is installed between the motor section and reducer section as shown in Figure B-17. On oil lubricated units a slinger type oil seal is used — Figure B-18.

**Fig. B-17 Single Lip Type: Grease Lubed Units**



**Fig. B-18 Slinger Type: Oil Lubed Units**



**Note:** For oil seal replacement sizes see Table B-28.

# BEARINGS, OIL SEALS FOR MOTOR

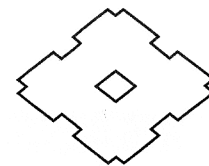
Table B-28. Bearings and Oil Seal Sizes<sup>[1]</sup>

Motor Frame Number	Motor		Cyclo Frame Size	Bearing <sup>[2]</sup>		Oil Slinger Part Number <sup>[3]</sup>	Oil Seal Size <sup>[3]</sup>
	HP	RPM		Non-Drive End	Drive End		
F-63S	1/8	1800	6060, 6065	6202ZZ-CM	6302ZZ-CM	-	20 x 35 x 8
			6070, 6075	6202ZZ-CM	6302ZZ-CM	-	20 x 35 x 8
			6080, 6085	6202ZZ-CM	6302ZZ-CM	-	20 x 35 x 8
			6090, 6095	6202ZZ-CM	6303ZZ-CM	-	22 x 35 x 7
F-63M	1/4	1800	6060, 6065	6202ZZ-CM	6302ZZ-CM	-	20 x 35 x 8
			6070, 6075	6202ZZ-CM	6302ZZ-CM	-	20 x 35 x 8
	6080, 6085		6202ZZ-CM	6302ZZ-CM	-	20 x 35 x 8	
	6090, 6095		6202ZZ-CM	6303ZZ-CM	-	22 x 35 x 7	
	1/3		6100, 6105	6202ZZ-CM	6303ZZ-CM	-	22 x 35 x 7
F-71M	1/2	1800	6070, 6075	6202ZZ-CM	6302ZZ-CM	-	20 x 35 x 8
			6080, 6085	6202ZZ-CM	6302ZZ-CM	-	20 x 35 x 8
			6090, 6095	6202ZZ-CM	6303ZZ-CM	-	22 x 35 x 7
			6100, 6105	6202ZZ-CM	6303ZZ-CM	-	22 x 35 x 7
			6110, 6115	6202ZZ-CM	6303ZZ-CM	-	22 x 35 x 7
			6120, 6125	6202ZZ-CM	6305ZZ-CM	-	30 x 45 x 8
F-80S F-80M	3/4	1800	6080, 6085	6303ZZ-CM	6302ZZ-CM	-	20 x 35 x 8
			6090, 6095	6203ZZ-CM	6303ZZ-CM	-	22 x 35 x 7
	6100, 6105		6203ZZ-CM	6303ZZ-CM	-	22 x 35 x 7	
	6110, 6115		6203ZZ-CM	6303ZZ-CM	-	22 x 35 x 7	
	1		6120, 6125	6203ZZ-CM	6205ZZ-CM	-	30 x 45 x 8
F-90S F-90L	1½	1800	6130, 6135	6203ZZ-CM	6206ZZ-CM	ET713WW-G01	(40 x 62 x 12)
			6095	6204ZZ-CM	6303ZZ-CM	-	25 x 45 x 8
	6100, 6105, 610H		6204ZZ-CM	6204ZZ-CM	-	26 x 42 x 8	
	6110, 6115		6204ZZ-CM	6204ZZ-CM	-	26 x 42 x 8	
	6120, 6125, 612H		6204ZZ-CM	6205ZZ-CM	-	30 x 45 x 8	
	6130, 6135, 6140, 6145, 614H		6204ZZ-CM	6206ZZ-CM	ET713WW-G01	(40 x 62 x 12)	
	6160, 6165		6204ZZ-CM	6307ZZ-CM	ET714WW-G01	(45 x 68 x 12)	
F-100L	3	1800	610H	6205ZZ-CM	6204ZZ-CM	-	26 x 42 x 8
			6110, 6115	6204ZZ-CM	6204ZZ-CM	-	26 x 42 x 8
			6120, 6125, 612H	6205ZZ-CM	6205ZZ-CM	-	30 x 45 x 8
			6130, 6135, 6140, 6145, 614H	6205ZZ-CM	6206ZZ-CM	ET713WW-G01	40 x 62 x 12
			6160, 6165, 616H	6205ZZ-CM	6307ZZ-CM	ET714WW-G01	45 x 68 x 12
F-112M	5	1800	6110, 6115	6205ZZ-CM	6204ZZ-CM	-	26 x 42 x 8
			6120, 6125, 612H	6206ZZ-CM	6305ZZ-CM	-	-
			6130, 6135, 6140, 6145, 614H	6206ZZ-CM	6206ZZ-CM	ET713WW-G01	(40 x 62 x 12)
			6160, 6165, 616H	6206ZZ-CM	6307ZZ-CM	ET714WW-G01	(45 x 68 x 12)
			6170, 6175	6206ZZ-CM	6308ZZ-CM	CD4-4503-G01	(50 x 80 x 14)
			6180, 6185	6206ZZ-CM	6309ZZ-CM	CD4-4504-G01	(55 x 85 x 14)
F-132S	7½	1800	612H	6206ZZ-CM	6206ZZ-CM	-	(30 x 45 x 8)
			6130, 6135, 6140, 6145, 614H	6206ZZ-CM	6206ZZ-CM	ET713WW-G01	(40 x 62 x 12)
			6160, 6165, 616H	6206ZZ-CM	6307ZZ-CM	ET714WW-G01	(45 x 68 x 12)
			6170, 6175	6206ZZ-CM	6308ZZ-CM	CD4-4503-G01	(50 x 80 x 14)
			6180, 6185	6206ZZ-CM	6309ZZ-CM	CD4-4504-G01	(55 x 85 x 14)
			6190, 6195	6206ZZ-CM	6311ZZ-CM	CD4-4269-G01	(60 x 90 x 14)
F-132M	10	1800	6130, 6135, 6140, 6145, 614H	6307ZZ-CM	6306ZZ-CM	ET713WW-G01	(40 x 62 x 12)
			6160, 6165, 616H	6307ZZ-CM	6307ZZ-CM	ET714WW-G01	(45 x 68 x 12)
			6170, 6175	6307ZZ-CM	6309ZZ-CM	CD4-4504-G01	(55 x 85 x 14)
			6180, 6185	6307ZZ-CM	6310ZZ-CM	CD4-4269-G01	(60 x 90 x 14)
			6190, 6195	6307ZZ-CM	6311ZZ-CM	CD4-2814-G01	(65 x 95 x 14)

Notes: [1] For 6 pole motors not shown, please consult factory.

[2] CM indicates radial clearance selected for electric motor application.

[3] Oil slinger, which includes oil seal, is standard on oil lubricated Cyclo gearmotors. Oil seal size shown in ( ) is used only when an oil lubricated Cyclo gearmotor is special ordered as grease lubricated.



**Table B-28. Bearings and Oil Seal Sizes<sup>[1]</sup> (cont.)**

Motor Frame Number	Motor		Cyclo Frame Size	Bearing <sup>[2]</sup>		Oil Slinger Part Number <sup>[3]</sup>	Oil Seal Size <sup>[3]</sup>
	HP	RPM		Non-Drive End	Drive End		
F-160M	15	1800	614H	6307ZZ-CM	6306ZZ-CM	ET713WW-G01	(40 x 62 x 12)
			6160, 6165, 616H	6307ZZ-CM	6307ZZ-CM	ET714WW-G01	(45 x 68 x 12)
			6170, 6175	6307ZZ-CM	6309ZZ-CM	CD4-4504-G01	(55 x 85 x 14)
			6180, 6185	6307ZZ-CM	6310ZZ-CM	CD4-4269-G01	(60 x 90 x 14)
			6190, 6195	6307ZZ-CM	6311ZZ-CM	CD4-2814-G01	(65 x 95 x 14)
			6205	6307ZZ-CM	6311ZZ-CM	CD4-4269-G01	(60 x 90 x 14)
			6215	6307ZZ-CM	6312ZZ-CM	CD4-2814-G01	(65 x 95 x 14)
G-160L	20 15	1800 1200	614H	6309ZZ-CM	6306ZZ-CM	ET713WW-G01	(40 x 62 x 12)
			6160, 6165, 616H	6309ZZ-CM	6308ZZ-CM	ET714WW-G01	(45 x 68 x 12)
			6170, 6175	6309ZZ-CM	6309ZZ-CM	CD4-4504-G01	(55 x 85 x 14)
			6180, 6185	6309ZZ-CM	6311ZZ-CM	CD4-2814-G01	(65 x 95 x 14)
			6190, 6195	6309ZZ-CM	6311ZZ-CM	CD4-2814-G01	(65 x 95 x 14)
			6205	6309ZZ-CM	6312ZZ-CM	CD4-4269-G01	(60 x 90 x 14)
			6215	6309ZZ-CM	6313ZZ-CM	CD4-2814-G01	(65 x 95 x 14)
F-180MG	25, 30 20	1800 1200	6165, 616H	6312ZZ-CM	6308ZZ-CM	ET714WW-G01	(45 x 68 x 12)
			6175	6312ZZ-CM	6309ZZ-CM	CD4-4504-G01	(55 x 85 x 14)
			6180, 6185	6312ZZ-CM	6311ZZ-CM	CD4-2814-G01	(65 x 95 x 14)
			6190, 6195	6312ZZ-CM	6313ZZ-CM	CD4-2816-G01	(80 x 115 x 15)
			6205	6312ZZ-CM	6312ZZ-CM	CD4-4269-G01	(60 x 90 x 14)
			6215	6312ZZ-CM	6313ZZ-CM	CD4-2814-G01	(65 x 95 x 14)
			6225	6312ZZ-CM	6314ZZ-CM	CD4-2815-G01	(75 x 100 x 13)
F-180L	40 25 30	1800 1200	6190, 6195	6312ZZ-CM	6313ZZ-CM	CD4-2816-G01	(80 x 115 x 15)
			6205	6312ZZ-CM	6312ZZ-CM	CD4-4269-G01	(60 x 90 x 14)
			6215	6312ZZ-CM	6313ZZ-CM	CD4-2814-G01	(65 x 95 x 14)
			6225	6312ZZ-CM	6314ZZ-CM	CD4-2815-G01	(75 x 100 x 13)
			6235	6312ZZ-CM	NU314G1	DT218WW-G01	(80 x 115 x 15)
			6245	6312ZZ-CM	NU315G1	CD4-3160-G01	(105 x 130 x 13)
			6205	6312ZZ-CM	6312ZZ-CM	CD4-4269-G01	(60 x 90 x 14)
F-200L	50 60 40 50	1800 1200	6215	6312ZZ-CM	6313ZZ-CM	CD4-2814-G01	(65 x 95 x 14)
			6225	6312ZZ-CM	6314ZZ-CM	CD4-2815-G01	(75 x 100 x 13)
			6235	6312ZZ-CM	NU314G1	DT218WW-G01	(80 x 115 x 15)
			6245	6312ZZ-CM	NU315G1	CD4-3160-G01	(105 x 130 x 13)
			6255	21312	NU317G1	CD4-2817-G01	(110 x 140 x 14)
			6265	21312	NU318G1	CD4-3161-G01	(120 x 150 x 14)
			6215	6314ZZ-CM	6313ZZ-CM	CD4-2814-G01	(65 x 95 x 14)
F-225S	75 60	1800 1200	6225	6314ZZ-CM	6314ZZ-CM	CD4-2815-G01	(75 x 100 x 13)
			6235	6314ZZ-CM	NU314G1	DT218WW-G01	(80 x 115 x 15)
			6245	6314ZZ-CM	NU315G1	CD4-3160-G01	(105 x 130 x 13)
			6255	6314ZZ-CM	NU317G1	CD4-2817-G01	(110 x 140 x 14)
			6265	6314ZZ-CM	NU318G1	CD4-3161-G01	(120 x 150 x 14)
			6235	6314ZZ-CM	NU314G1	DT218WW-G01	(80 x 115 x 15)
F250S	75	1200	6245	6314ZZ-CM	NU315G1	CD4-3160-G01	(105 x 130 x 13)
			6255	6314ZZ-CM	NU317G1	CD4-2817-G01	(110 x 140 x 14)

Notes: [1] For 6 pole motors not shown, please consult factory.

[2] CM indicates radial clearance selected for electric motor application.

[3] Oil slinger, which includes oil seal, is standard on oil lubricated Cyclo gearmotors. Oil seal size shown in ( ) is used only when an oil lubricated Cyclo gearmotor is special ordered as grease lubricated.

# DISASSEMBLY/ASSEMBLY OF GEARMOTOR

---

## Disassembly:

SM-CYCLO® Gearmotors are designed to provide maximum ease in disassembly and reassembly; they require no special maintenance skills.

The following procedures and precautions are recommended at time of disassembly and assembly:

- Perform work in a dust-free, humidity-free area.
  - Use a soft or plastic hammer when required.
  - Take care not to damage parts, i.e., coil, bearings, seals, etc.
  - Inspect all components and replace as necessary.
  - Be extremely careful when handling bearings.
1. Remove the complete SM-CYCLO® Gearmotor from the driven machine.
  2. Place the gearmotor vertically with the output shaft upward.
  3. Remove the through bolts from the motor flange, ring gear housing, and lift the slow speed side, thus separating the unit into two parts so that the inner mechanism can be removed (Fig. B-19 ~ B-24).
  4. If the unit will not separate easily, gently drive a wedge at the line X shown in Fig. B-1 on page B-3 (if this produces a burr, be sure to remove it before reassembly).
  5. To lift the slow speed side, attach an eyebolt to the tapped hole on the end of the slow speed shaft and use a hoist or chain block (Fig. B-19).
  6. Take out the slow speed shaft rollers, item 1-06, page B-3 (Fig. B-20). Check the slow speed shaft pins (1-01) to see whether any rollers have adhered to them.

7. Using both hands, lift out the top cycloid disc (2-04) on the slow speed side (Fig. B-21).

8. Remove the spacer ring (2-05).

9. The eccentric bearing assembly (3-04) can be removed from the motor shaft after taking out the retaining ring (3-10), or the bearings (3-02), figures B-22, B-23.

**Note:** In certain sizes, the eccentric bearings are roller bearings without a retainer. Remove rollers of the top disc and the second disc on the motor side before removing the eccentric.

10. Take out the second disc located on the motor side.

11. Remove the ring gear housing (2-01) from the motor.

12. Follow these steps to remove the slow speed shaft (1-01) with its bearings from the casing (26): (a) Remove the horizontal oil seal housing (25). (b) With a wooden or hard rubber mallet, rap the inner end of the slow speed shaft to expose the retaining ring\* from the outer raceway of the bearing. (c) Remove the retaining ring. (d) Rap the outer end of the slow speed shaft with a wooden or hard rubber mallet, and remove it from the casing.

13. The cycloid disc is made from heat treated bearing steel and the spacer ring is cast iron. Take care not to strike them together while handling.

**\*Note 1:** Retaining ring is part of bearing A. (See Part 1-02)

**2:** If motor is in need of repair, please send to any authorized EASA shop.

---

## Assembly

SM-CYCLO® Gearmotors are reassembled by reversing the disassembly procedure. Care must be taken to exclude dust or foreign matter from the moving parts, and to see that gaskets are properly placed to make the assembly oil-tight.

Following are some helpful points to remember when assembling SM-CYCLO® Gearmotors.

1. Set the ring gear housing and insert the ring gear pins and rollers; then test-rotate the pins and rollers by hand. (Apply grease liberally to the ring gear pins and rollers before they are inserted in grease lubricated SM-CYCLO® Gearmotors).
2. Cycloid discs are a matched pair. Each carries the same number stamped on one side of the disc.
3. Set the cycloid disc with the stamped number face up as shown in figure B-24.

4. Insert the eccentric bearing by rapping with a wooden or hard rubber mallet (Fig. B-23).

5. Insert the spacer and the inner bearing raceway. Secure them with the retaining ring (Fig. B-22).

6. Set the spacer ring in place.

**7. Insert top disc in such a way that the mark is 180° opposed to the mark on the bottom disc (Fig. 20).**

8. Insert slow speed shaft rollers (Fig. B-20).

9. Put the slow speed shaft pins into the rollers (Fig. B-19). The above instructions are for **eccentric bearings with retainer**. Following are the instructions suggested for **roller bearings without retainer**:

a. First insert the eccentric with inner raceways of bearings by rapping with a wooden or hard rubber mallet.



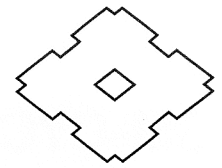


Fig. B-19

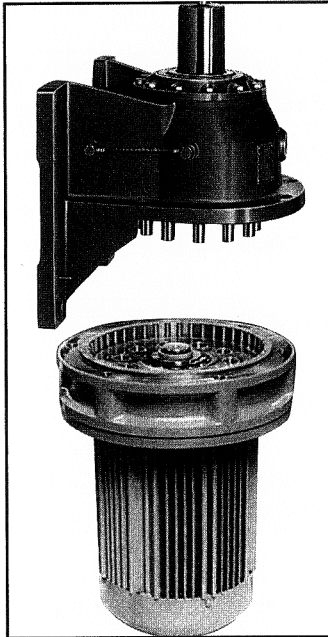


Fig. B-20

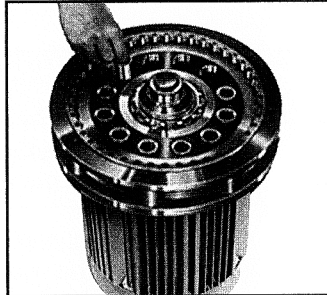


Fig. B-23

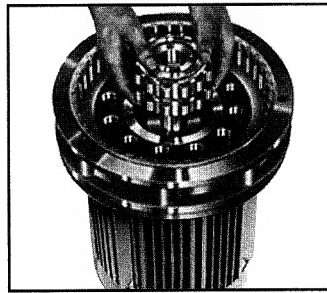


Fig. B-21

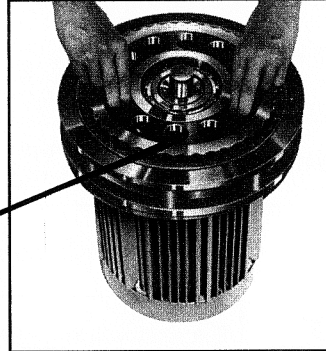


Fig. B-22

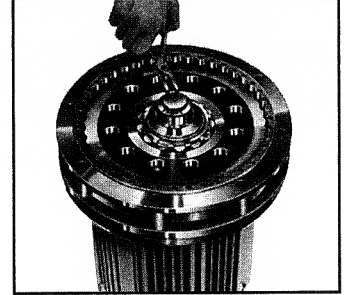
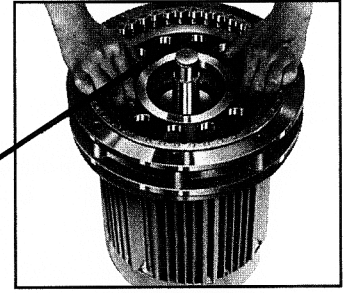


Fig. B-24



**Note:** Insert second disc with number facing slow speed side, exactly 180° opposed to number on first disc.

**Note:** Set disc with number facing slow speed side.

b. Apply grease to the raceway of the eccentric on the disc. Fix the rollers and set disc in place.

c. Insert the spacer ring and set second disc in such a way that mark is 180° opposed to mark on the bottom disc.

**Eccentric Bearing Replacement Precautions**

The eccentric bearings are specially designed for installation on SM-CYCLO® Reducers. They are special roller bearings without outer raceways (refer to the list of bearings on page B-12 ~ B-13).

It is necessary to insert replacement bearings with numbered surfaces of the inner raceways facing outward. Note that incorrect insertion of the bearings (i.e., insertion of bearings with numbered surfaces inside) causes trouble.

**Disassembly and Assembly of Sizes 6060-6095 SM-CYCLO® Reducers**

Small sizes 6060-6095 have a single disc system, so they differ in construction from larger sizes in the following ways:

1. A balance weight is provided in lieu of the two-disc system. Refer to figure B-25.
2. The balance weight keyway must be in line with the eccentric keyway.
3. There are no end plates on either side of the eccentric. In all other respects, they have exactly the same construction as the larger sizes. Follow the instructions given under "Disassembly and Assembly".

**Disassembly Of Output Side (6060-612H)**

1. With casing supported, tap output shaft until it is disengaged from casing.
2. Remove bearing "A" by using pulling tool.
3. Replace all bearings, gaskets and seals when reassembling (Pages B-11 ~ B-13).

**Assembly Of Output Side (6060-612H)**

1. Assemble the "B" Bearing (Part No. 1-03) on the slow speed shaft (Part No. 1-01). Heating of "B" bearing is recommended for easier assembly.

**Note:** Do not exceed temperature of 200°F.

2. Assemble the casing (Part No. 26) over the slow speed shaft (Part No. 1-01), being sure to maintain "x" (Fig. B-25).

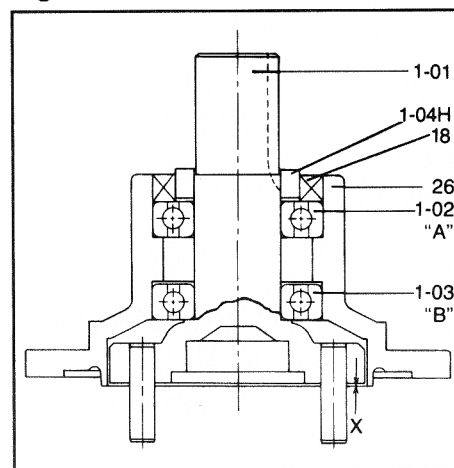
3. Carefully tap bearing "A" (Part No. 1-02) onto the slow speed shaft (Part No. 1-01) until the bearing is flush with the shoulder of the casing.

4. Place the collar (Part No. 1-04H) onto the slow speed shaft (Part No. 1-01). Heating the collar is recommended for easier assembly.

5. Insert the oil seal (Part No. 18), lip in, into the casing (Part No. 26).

**Note:** Measure for dimension "x" preferably in 3 places to insure proper spacing.

Fig. B-25



X" Dimension (inches)

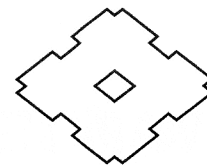
Frame Size	Dimension
6060/65	0.046 ± 0.007
6070/75 6080/85	0.042 ± 0.007
6090/95	0.046 ± 0.007
6100/05 610H	0.046 ± 0.007
6110/15/20/ 25, 612H	0.042 ± 0.007

# SM-CYCLO® Reducer Troubleshooting and Repair

This troubleshooting guide is to help you identify and overcome common problems of reducers and motors. If you have a problem not listed below, please consult factory.

PROBLEM WITH THE REDUCER		POSSIBLE CAUSES	SUGGESTED REMEDY
Runs Hot	Overloading	Load exceeds the capacity of the reducer	Check rated capacity of reducer, replace with unit of sufficient capacity or reduce load.
	Improper Lubrication	Insufficient lubrication	Check lubricant level and adjust up to recommended levels.
		Excessive lubrication	Check lubricant level and adjust down to recommended level.
		Wrong lubricant	Flush out and refill with correct lubricant as recommended.
Vibration or Noise	Loose Foundation Bolts	Weak mounting structure	Inspect mounting of reducer. Tighten loose bolts and/or reinforce mounting & structure.
		Loose hold down bolts	Tighten bolts.
	Worn Disc	Overloading unit may result in damage to disc	Disassemble and replace disc. Re-check rated capacity of reducer.
	Failure of Bearings	May be due to lack of lubricant	Replace bearing. Clean and flush reducer and fill with recommended lubricant.
		Overload	Check rated capacity of reducer, replace with unit of sufficient capacity or reduce load.
	Insufficient Lubricant	Level of lubricant in the reducer not properly maintained	Check lubricant level and adjust to factory-recommended level.
Damaged Pins & Rollers	Overloading of reducer	Disassemble and replace ring gear pins and rollers. Check load on reducer.	
Output Shaft Does Not Turn	Motor Shaft Broken	Overloading of reducer can cause damage	Replace broken shaft. Check rated capacity of reducer.
		Key missing or sheared off on input shaft	Replace key.
	Eccentric Bearing Broken	Lack of lubricant	Replace eccentric bearing. Flush and refill with recommended lubricant.
	Motor Doesn't Turn	Motor	Refer to page B-23.
Oil Leakage	Worn Seals	Caused by dirt or grit entering seal	Replace seals. Breather filter may be clogged. Replace or clean filter.
	Leakage Into Motor	Overfilled reducer	Check lubricant level and adjust to recommended level.
		Vent clogged	Clean or replace element, being sure to prevent any dirt from falling into the reducer.
		Improper mounting position, such as wall or ceiling mount of horizontal reducer	Mount horizontally or rework reducer to wall or ceiling mount.

# SM-CYCLO<sup>®</sup> Motor Troubleshooting and Repair



PROBLEM WITH THE MOTOR		POSSIBLE CAUSES	SUGGESTED REMEDY	
Load is disconnected but motor doesn't rotate	Makes a groaning sound	Faulty switch contact	Adjust the contact.	
		Blown fuse	Replace.	
		One phase wire of the power supply open	Replace.	
		Stator coil open	Repair by rewinding or replacing stator assembly.	
		Stator and rotor touching due to bearing housing wear	Replace the bearing and bracket.	
	Starts in either direction when turned by hand	Three-phase is operating as single-phase	Check the power source with a voltmeter.	
	Doesn't make any noise	Stator coil open	Repair by rewinding or replacing stator assembly.	
Outside the motor Power failure Open connection wire Faulty switch contact Faulty starter contact		Contact the power company. Check the source wiring. Adjust the contact.		
Rotates with the load disconnected, but:	Rotates in the wrong direction	Connection error	Change any two of the three phase source.	
	Fuse blows	Shorted lead wire	Replace.	
	Speed doesn't increase	Faulty starter contact	Adjust.	
	Groans	Overcurrent/ Overheating	Rotor and stator touching.	Repair by rewinding or replacing stator assembly.
		Over-current	One phase of stator coil shorted.	Replace the stator winding.
	Makes a high-pitched metallic noise	Faulty bearing	Replace the bearing.	
Rotates when the load is disconnected but when the load is connected it:	Switch overheated	Insufficient switch capacity	Replace with one having the rated capacity.	
		Overload	Drop to the rated load.	
	Fuse blows	Insufficient fuse capacity	Replace with one having the rated capacity.	
	Overheats	Overload	Drop to the rated load.	
		Voltage drop	Consult with the power company.	
	Speed suddenly drops	Voltage drop	Consult with the power company.	
		Overload	Drop to the rated load.	
	Stops	Bearing damaged by overheat	Replace the bearing.	

# MAINTENANCE AND INSPECTION

To insure long life and trouble-free operation, periodic inspection and maintenance of your gearmotor is recommended.

## Daily Inspection:

1. Check for loose nuts and bolts.
2. Check for cooling fan air obstruction.
3. Listen for abnormal sounds.
4. Check for abnormal temperature and vibration by carefully placing hand on unit (caution: be extremely careful when making direct contact with the unit to avoid burns from abnormal temperatures).
5. Visually check the oil level gauge on the vertical unit, forced-lubricated type. Check lubrication flow by viewing piping set and oil signal (Part No. 41). Faulty operation is caused by a lack of lubrication oil, damage to the plunger pump (Part No. 42) or the positive displacement pump (Part No. 43) or the clogging of pipes, etc. In case of faulty operation, stop and inspect the unit immediately.

6. A temperature rise of approximately 105°F (40.6°C) above ambient on the surface of the ring gear housing (Part No. 2-01) is allowable if the temperature fluctuation is small. If temperature rises rapidly from stable condition, add the recommended oil or grease (Tables B-7 and B-11). A rapid temperature rise may be caused from a lack of lubrication. If after lubricating unit, the problem persists, stop operation and consult factory.

7. When an abnormal sound is heard from inside the unit, stop operation and inspect the unit.

8. If the lubrication oil leaks, replace the damaged or worn part with a new one. (Refer to Part No. 1-04H, Page B-3.)

## Periodic Inspection:



1. Replenish grease in the motor bearings; for quantities, refer to Table B-27, Page B-17.
2. Check installation resistance in accordance with instructions as shown on Page B-16, Step 3.

## Ordering Correct Replacement Units Or Parts

The SM-CYCLO® Gearmotor is fully standardized to offer maximum part interchangeability among models of the same frame size. However there are many frame sizes, models, and types in the production range of SM-CYCLO®. Therefore to get correct replacement units or parts, proper information to identify the speed reducer in question is essential. The name plate, which is secured to the body of the drive, provides this identifying data.

Please give the full description shown on the name plate to your distributor. Be sure to include the *SERIAL NUMBER* and *MODEL NUMBER*. This information, along with our production records, will enable us to provide you with the correct replacement unit or parts.

### Name Plate on SM-CYCLO® Gearmotor

<b>SM-CYCLO®</b>		<b>CHESAPEAKE, VIRGINIA</b>			
MODEL	<input type="text"/>				
MOTOR H.P.	<input type="text"/>	CLASS	<input type="text"/>		
OUTPUT R.P.M.	<input type="text"/>	RATIO	<input type="text"/>		
SERIAL NO.	<input type="text"/>	DATE	<input type="text"/>		
 <b>SUMITOMO</b> MACHINERY CORP. OF AMERICA					

## Storage and Operation After Storage

### Storage 6 Months–1 Year

#### Oil-Lubricated

1. Fill unit(s) with 20% of the recommended quantity as shown in Table B-12, Page B-9 with a rust preventive oil (NP20 or equivalent) or a circulating oil (Shell VSI No. 100 or equivalent).
2. At approximately 3 months interval, change oil as described in No. 1.

#### Grease-Lubricated

Grease lubricated models do not require any special attention during storage. (Inspect unit before operation.)

**Note:** For both the Oil-Lubricated and Grease-Lubricated models, if units are to be stored for a period exceeding 1 year, consult factory.

### Operation After Storage of 6 Months–1 Year

#### Oil-Lubricated

1. Completely drain the rust preventive, or circulating oil from unit.
2. Flush unit with the recommended operating oil as shown in Table B-11.
3. After flushing, fill the unit to the proper oil level with the recommended lubricating oil.

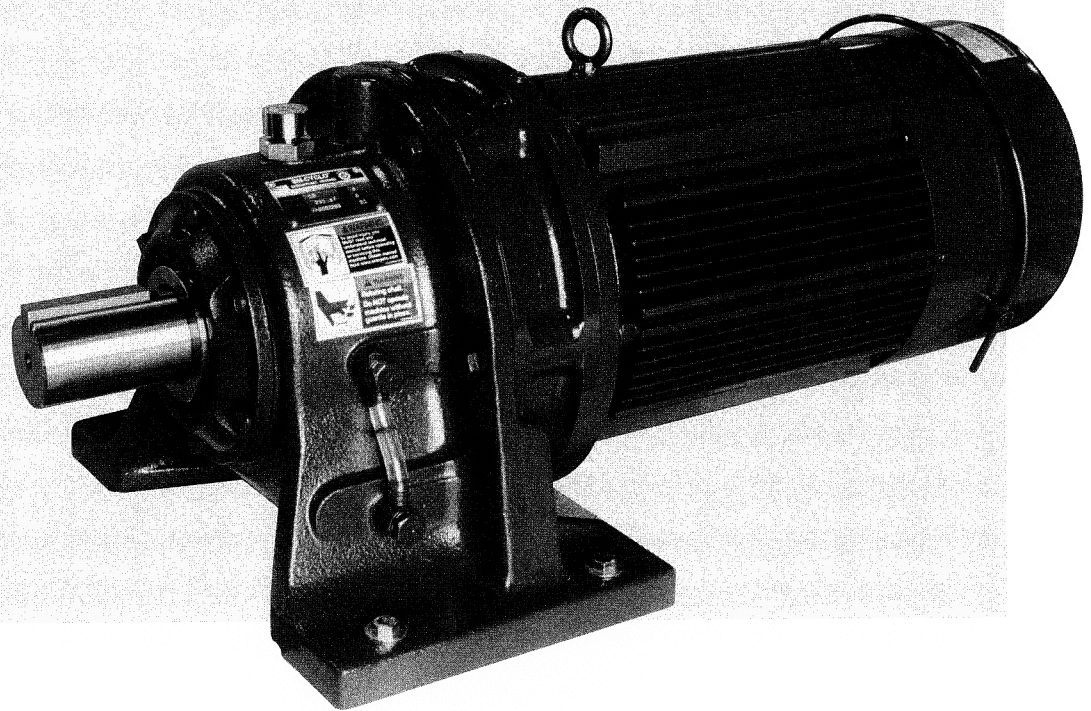
#### Grease-Lubricated

Add 1/2 of the recommended quantity of new grease as shown in Table B-10.

**Note:** Consult the factory before operating units stored for periods greater than 1 year.

---

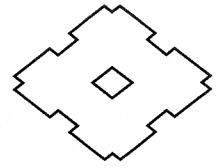
# SM-CYCLO<sup>®</sup> BRAKEMOTORS



# SECTION C CONTENTS

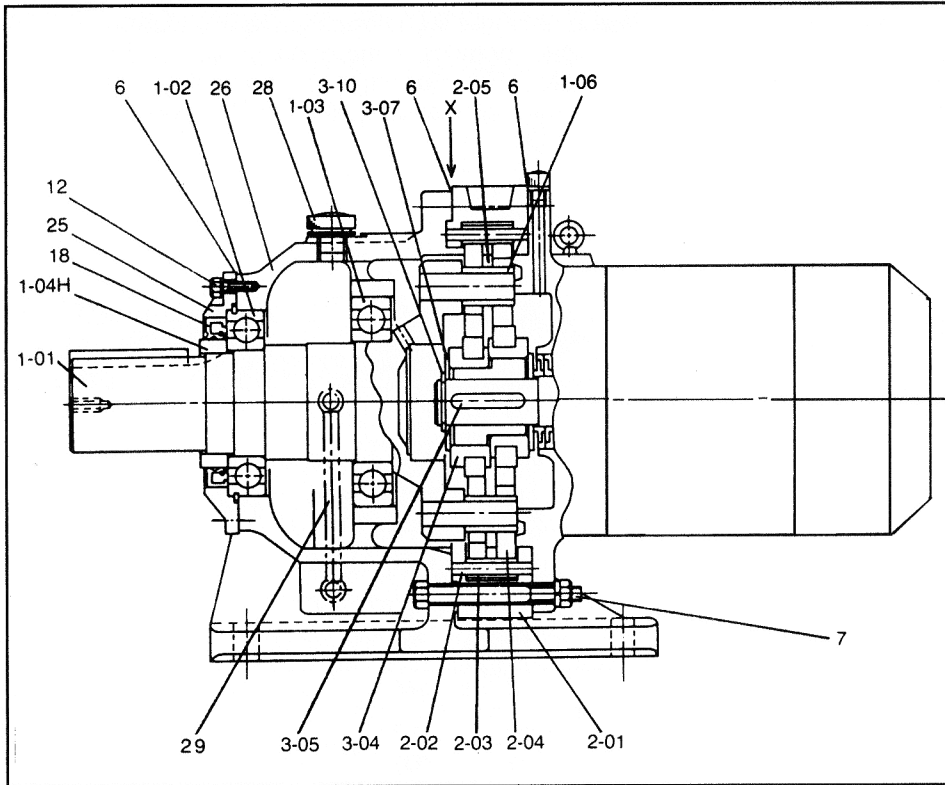
---

	Page
<b>GENERAL CONSTRUCTION</b> .....	C-3
<b>FB MODELS</b> .....	C-4 ~ 12
Standard Specifications .....	C-4
Construction, Operation & Maintenance .....	C-5~9
Models FB-01A, -02A, -05A .....	C-5
Models FB-1B, -2B, -3B .....	C-6, 7
Models FB-5B, -8B, -10B, -15B .....	C-6, 7
Wiring Diagrams .....	C-10, 11
Troubleshooting .....	C-12
<b>MODEL CMB-20</b> .....	C-13 ~ 14
Construction, Operation, Wiring .....	C-13
Wiring, Maintenance, Troubleshooting .....	C-13

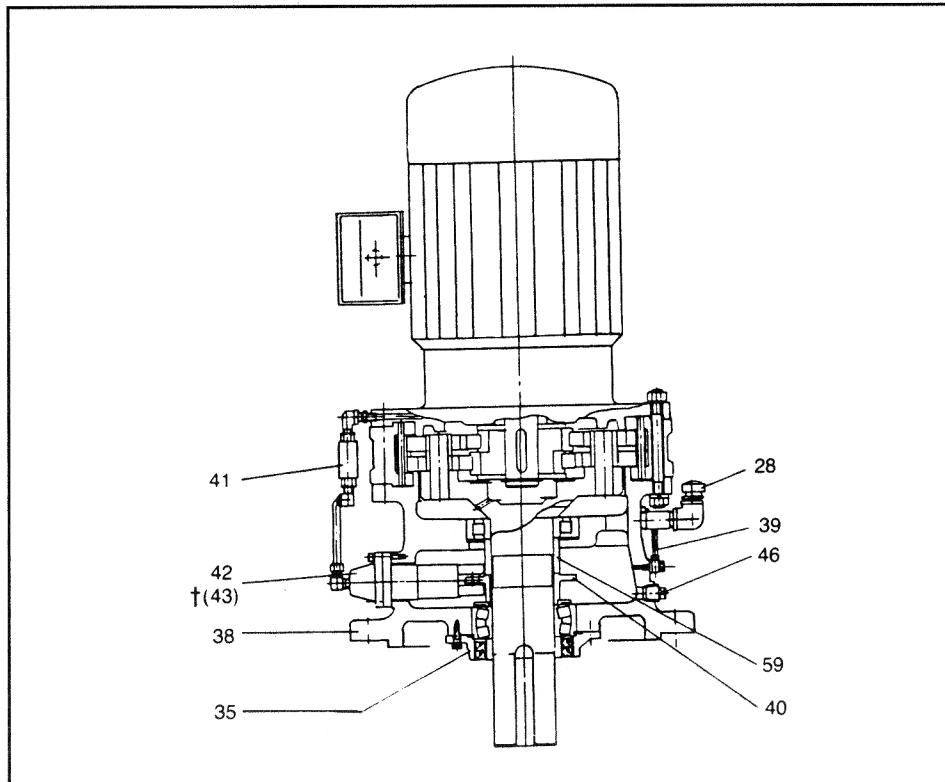


# GENERAL CONSTRUCTION

**Fig. C-1 Single Reduction (Horizontal Foot Mount)**



**Fig. C-2 Single Reduction (Vertical Base Mount)**



**Table C-1. Main Parts**

Part No.	Part Name
1-01	Slow Speed Shaft w/Pins
1-02	Bearing A
1-03	Bearing B
1-04H	Oil Seal Collar—Horizontal
1-06	Slow Speed Shaft Rollers
2-01	Ring Gear Housing
2-02	Ring Gear Pins
2-03	Ring Gear Rollers
2-04	Cyclo Disc
2-05	Spacer Ring
3-04	Eccentric Bearing Assembly
3-05	Eccentric Key
3-06	Balance Weight
3-07	Spacer
3-10	Retaining Ring
5-01	Intermediate Shaft w/Pins
5-02	Bearing F
5-03	Bearing G
5-04	Eccentric Bearing Assembly
6	Gasket Set
7	Casing Nuts & Bolts
12	Bolts for SS Oil Seal Housing
15	Grease Nipple
18	Slow Speed Output Oil Seal
25	Horizontal Oil Seal Housing
26	Horizontal Case
28	Oil Fill Plug
29	Oil Gauge—Horizontal Unit
35	Vertical Oil Seal Housing
38	Vertical Case (Integral V Type)
39	Oil Gauge—Vertical Unit
40	Cam
41	Piping Set & Oil Signal
42	Plunger Pump
†43	Positive Displacement Pump
46	Drain Plug
55	Intermediate Cover
57	Eye Bolt
*59	Spacer

\*Pt. No. 59 — frame sizes 6205-6275 only.

†Refer to Table B-13 on Page B-9 for units that require a positive displacement pump.

# FB MODELS STANDARD SPECIFICATIONS

## Introduction

SM-CYCLO FB series brakemotors were developed to be mechanically rugged in design, electrically reliable and efficient in operation. This manual has been written to provide all the necessary information to insure long and trouble-free service.

Please note that the information in this manual specifically pertains to the brake portion of the gearmotor. For information on the basic gearmotor, please refer to Section B, SM-CYCLO Gearmotors, of this manual.

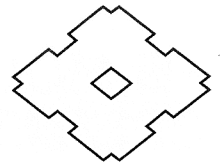
## Standard Brakemotor Specifications Table C-2.

Brake <sup>[1]</sup> Type	Motor HP	Brake Torque ft-lb	Inertia WK <sup>2</sup> lb-ft <sup>2</sup>	Brake Coil	Brake Current (A)		Coil Resis ohms	Brake Delay Time <sup>[2]</sup> (seconds)	
					230V	460V		Normal	Fast
FB-01A	1/8	0.7	0.0083	DC Energized Type, Built-in Rectifier within Conduit Box	0.1	0.06	2700	0.15 ~ 0.2	0.015 ~ 0.02
FB-02A	1/4 1/3	1.4 1.4	0.0131		0.1	0.06	1791	0.15 ~ 0.2	0.015 ~ 0.02
FB-05A	1/2	2.9	0.016		0.1	0.06	1791	0.1 ~ 0.15	0.01 ~ 0.015
FB-1B	3/4 1	5.8 5.8	0.0267 0.0308		0.1	0.1	1470	0.2 ~ 0.3	0.01 ~ 0.02
FB-2B	1.5 2	11 11	0.0504 0.0558		0.3	0.2	589	0.2 ~ 0.3	0.01 ~ 0.02
FB-3B	3	16	0.0884		0.3	0.2	589	0.3 ~ 0.4	0.01 ~ 0.02
FB-5B	5	27	0.227		0.7	0.3	308	0.4 ~ 0.5	0.01 ~ 0.02
FB-8B	7.5	40	0.297		0.7	0.3	308	0.3 ~ 0.4	0.01 ~ 0.02
FB-10B	10	54	0.718		0.9	0.5	207	0.7 ~ 0.8	0.03 ~ 0.04
FB-15B	15	80	0.973		0.9	0.5	207	0.5 ~ 0.6	0.03 ~ 0.04

Notes: [1] Indoor types can be installed in any orientation for use.  
[2] Continuous time rating for both the brake and motor.



# FB MODELS – CONSTRUCTION OPERATION & MAINTENANCE



## MODELS FB-01A, -02A, -05A

### Construction

Fig. 3 illustrates the construction of the brake. The restraining bolt (4) fastens the brake shoe (10) and spacer (2) onto the stationary core (1). The armature plate (11) is kept from rotation by the restraining bolt (4), but moves axially by electromagnetic attraction and the tension of the pressure spring (12). The brake lining (3) is fitted to the hub (5), which is secured to the motor shaft with a key. The solenoid coil (13) is energized via a rectifier provided within the conduit box.

**Table C-3. FB-01A, -02A, -05A Parts**

No.	Part Name	No.	Part Name
1	Stationary Core*	9	Leaf Spring*
2	Spacer*	10	Brake Shoe*
3	Brake Lining*	11	Armature*
4	Restraining Bolt*	12	Pressure Spring*
5	Hub*	13	Solenoid Coil*
6	C-type Retaining Ring	14	Ball Bearing
7	Cover	15	Motor Shaft
8	Fan (TEFC model only)		

\*These parts are included in a complete brake kit.

### Operating Principles

The brake is a (fail safe type) spring actuated type brake that will release the brake mechanism when the solenoid coil is energized and engage when the coil is de-energized.

When power is applied to the unit, the solenoid coil and the electric motor will energize, and the energized coil attracts the armature plate (11) against the tension of the pressure spring (12). As a result, the brake lining (3) will disengage and the motor begins to run.

When the power is disconnected, the solenoid coil and the electric motor is de-energized. This causes the pressure spring (12) to actuate the armature plate (11), which in turn presses the brake lining (3) against the brake shoe (10) and brings the motor to a quick stop.

### Inspection, Adjustment and Maintenance

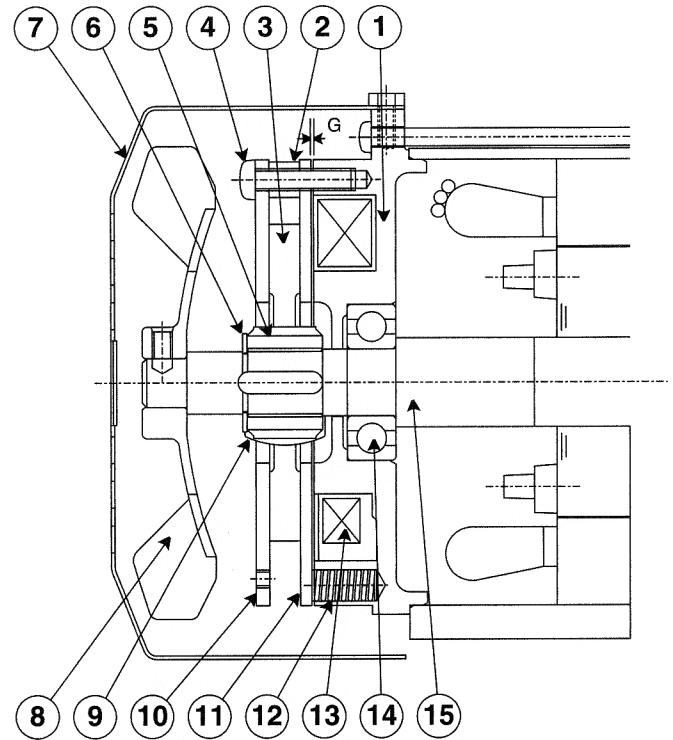
#### Inspection

Check the following points at regular intervals:

- The unit is operating normally.
- The brake lining is not worn excessively (or gap G is normal).
- All the mounting screws are securely tightened.

#### Gap Inspection and Adjustment

The brake lining will wear after the unit has been used for a long period of time. It is necessary to check the brake for gap G from time to time (Fig. C-3). Should gap G become too large, the solenoid coil may fail to pull in the armature plate and hence cannot release the brake, resulting in the unit remaining in a continuously braked condition.



**Fig. C-3 FB-01A, FB-02A, FB-05A Models**

#### Gap Inspection Procedure

- Remove cover (7).
- Insert a gap gage into the gap between stationary core (1) and armature plate (11), and measure the size of the gap. Adjustment is needed if the measured value is close to the allowable limit shown in Table C-4. Gap measurement should be made at three appropriate circumferential points.

#### Gap Adjustment Procedure

**If the brake lining is so heavily worn that gap adjustment is required, proceed as follows:**

- Remove cover (7).
- Loosen restraining bolt (4), rotate the brake shoe completely counterclockwise, and re-tighten the restraining bolt (4). After tightening the restraining bolt, measure the gap G to verify that it falls within the specification value and the allowable limit shown in Table C-4. (This procedure will reduce the gap by about 0.012 inch.)
- Check for brake performance by turning system power on and off a few times.
- Replace cover (7).

**Table C-4. Brake Gap & Brake Lining Size**

Brake Type	Gap value G (in)		Brake Lining Size	
	Spec. Value	Allowable Limit	Lining Dimensions	Initial Thickness
FB-01A	0.006 ~ 0.010	0.020		0.276
FB-02A				
FB-05A				

# FB MODELS – CONSTRUCTION, OPERATION & MAINTENANCE

## Models FB-1B, -2B, -3B

### Construction

Fig. C-4 illustrates the construction of the brake. The restraining bolt (7) fastens the brake shoe (15), gap adjusting sleeves (5) and spacer (4) onto the stationary core (1). The armature plate (16) is kept from rotation by the restraining bolt (7), but moves axially by electromagnetic attraction and the tension of the pressure spring (17). The brake lining (8) is fitted to the hub (10), which is secured to the motor shaft with a key. The solenoid coil (18) is energized via a rectifier provided within the terminal box.

Table C-5. FB-1B, -2B, -3B Parts

No.	Part Name	No.	Part Name
1	Stationary Core*	11	Retaining Ring
2	Brake Release Support	12	Fan Cover
3	Shifting Pin	13	Fan Set Pin
4	Spacer*	14	Fan
5	GAP Adjusting Sleeve*	15	Brake Shoe*
6	Brake Release Lever	16	Armature*
7	Restraining Bolt*	17	Pressure Spring*
8	Brake Lining*	18	Solenoid Coil*
9	Leaf Spring*	19	Fan Side Bearing
10	Hub*	20	Motor Shaft

\*These parts are included in a complete brake kit.

### Operating Principles

The brake is a (fail safe type) spring actuated type brake that will release the brake mechanism when the solenoid coil is energized and engage when the coil is de-energized.

When power is applied to the unit, the solenoid coil and the electric motor will energize, and the energized coil attracts the armature plate (16) against the tension of the pressure spring (17). As a result, the brake lining (8) will disengage and the motor begins to run.

When the power is disconnected, the solenoid coil and the electric motor is de-energized. This causes the pressure spring (17) to actuate the armature plate (16), which in turn presses the brake lining (8) against the brake shoe (15) and brings the motor to a quick stop.

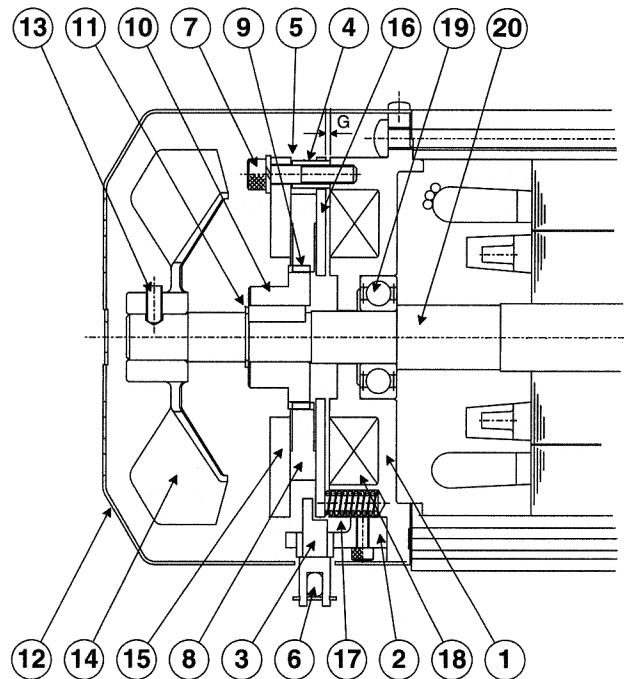


Fig. C-4 FB-1B, -2B, -3B Models

### Inspection, Adjustment and Maintenance

#### Inspection

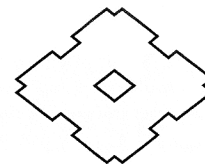
Check the following points at regular intervals:

- The unit is operating normally.
- The brake lining is not worn excessively (or gap G is normal).
- No screws in the unit are loose.

#### Manual brake release procedure

To manually release the brake with power to the unit off, use the brake release mechanism as follows:

FB-1B, -2B, and -3B brakemotors are equipped with a one-touch release mechanism. To disengage brake, pull out the brake release lever from its holder and push it forward toward the reducer. Releasing the lever will re-engage the brake.



## Models FB-1B, -2B, -3B (cont.)

### Gap inspection and adjustment

The brake lining will wear after the unit has been used for a long period of time. It is necessary to check the brake for gap G from time to time (Fig. C-4). Should gap G become too large, the solenoid coil may fail to pull in the armature plate and hence cannot release the brake, resulting in the unit remaining in a continuously braked condition.

### Gap Inspection Procedure

1. Remove fan cover (12).
2. Insert a gap gage into the gap between stationary core (1) and armature plate (16), and measure the size of the gap. Adjustment is needed if the measured value is close to the allowable limit shown in Table C-6. Gap measurement should be made at three appropriate circumferential points.

**Table C-6. Brake Gap Size**

Brake Type	Gap value G (in)	
	Spec. value	Allowable limit
FB-1B	0.008 ~ 0.012	0.020
FB-2B	0.008 ~ 0.012	0.020
FB-3B	0.008 ~ 0.012	0.028

### Gap Adjustment Procedure

**If the brake lining is so heavily worn that gap adjustment is necessary, proceed as follows:**

1. Remove fan cover (12). Measure the gap size to confirm the deviation from the specified value. The minimum adjustable setting is no less than the thickness of the GAP adjusting sleeve, 0.008 in.
2. Loosen set pin (13) and remove fan (14).
3. Slightly loosen restraining bolt (7), remove parts (4), (5), (7), and (15) as a set. Be careful not to remove only bolt (7) and loose sleeves (5).
4. The thickness of one gap adjusting sleeve (5) is 0.008 in. Decrease the number of the sleeves in use according to the degree of the wear. Reassemble parts (4), (5), (7), and (15) as a set.
5. After reassembly, check gap G. If the gap size is still too large, adjust the number of the sleeves again.
6. After completion of gap adjustment, check for brake performance by turning system power on and off a few times.
7. Replace fan (14), set pin (13) and cover (12).

### Brake lining replacement

When the brake lining has been worn to such a degree that its thickness has reached the allowable limit shown in Table C-7, or when sleeve adjustment is no longer an effective means of gap adjustment, replace the brake lining with a new one as follows:

1. Remove fan cover (12), measure gap G. Remove set pin (13) and fan (14).
2. Slightly loosen restraining bolt (7), then remove parts (4), (5), (7), and (15) as a set.
3. Take out brake lining (8) and measure its thickness. During removal of the lining, take care to prevent leaf spring (9) from coming off.
4. Install the new brake lining. Then, check to ensure that the lining moves along the hub (10) smoothly. Take care to ensure that the leaf spring (9) is not damaged or removed during the installation of the lining.
5. Replace the gap adjusting sleeves removed during gap adjustment. Then, reinstall parts (4), (5), (7), (15) as a set.
6. Measure gap G. Readjust if gap is out of the specification value.
7. Check for brake performance by turning system power on and off a few times. If no abnormalities are detected, replace fan (14), set pin (13) and cover (12).

**Table C-7. Brake Lining Size**

Brake Type	Brake lining dimension	Initial thickness $t_0$ (in)	Allowable thickness limit $t_0$ (in)
FB-1B		0.276	0.236
FB-2B		0.322	0.283
FB-3B		0.354	0.315

# FB MODELS – CONSTRUCTION, OPERATION & MAINTENANCE

## Models FB-5B, -8B, -10B, -15B

### Construction

Fig. C-5 and Fig. C-6 illustrate the construction of the brake. Among the brake parts, stationary core (1), solenoid coil (18), and stud bolt (3) constitute an integral sub-assembly unit. The armature plate (16) is kept from rotating by the stud bolt (3), but moves axially by electromagnetic attraction and the tension of the pressure spring (17). The adjusting washer (4) and spring washer (7) hold the brake shoe (15) against the nut (8) at all times. The brake lining (9) is fit to the hub (10), which is secured to the motor shaft with a key. The solenoid coil is energized via a rectifier provided within the terminal box.

Table C-8. FB-5B, -8B, -10B, -15B Parts

No.	Part Name	No.	Part Name
1	Stationary Core*	12	Fan Cover
2	Brake Release Support	13	Fan Set Screw or Pin
3	Stud Bolt*	14	Fan
4	GAP Adjusting Washer*	15	Brake Shoe*
5	Shifting Pin	16	Armature Plate*
6	Brake Release Lever	17	Pressure Spring*
7	Spring Washer*	18	Solenoid Coil*
8	Nut*	19	Fan Side Bearing
9	Brake Lining*	20	Motor Shaft
10	Hub*	21	Bearing Cover
11	Retaining Ring	22	Leaf Spring*

\*These parts are included in a complete brake kit.

### Operating Principles

The brake is a (fail safe type) spring actuated type brake that will release the brake mechanism when the solenoid coil is energized and engage when the coil is de-energized.

When power is applied to the unit, the solenoid coil and the electric motor will energize, and the energized coil attracts the armature plate (16) against the tension of the pressure spring (17). As a result, the brake lining (9) will disengage and the motor begins to run.

When the power is disconnected, the solenoid coil and the electric motor is de-energized. This causes the pressure spring (17) to actuate the armature plate (16), which in turn presses the brake lining (9) against the brake shoe (15) and brings the motor to a quick stop.

### Inspection, Adjustment and Maintenance

#### Inspection

Check the following points at regular intervals:

1. The unit is operating normally.
2. The brake lining is not worn excessively (or gap G is normal).
3. All the mounting screws are securely tightened.

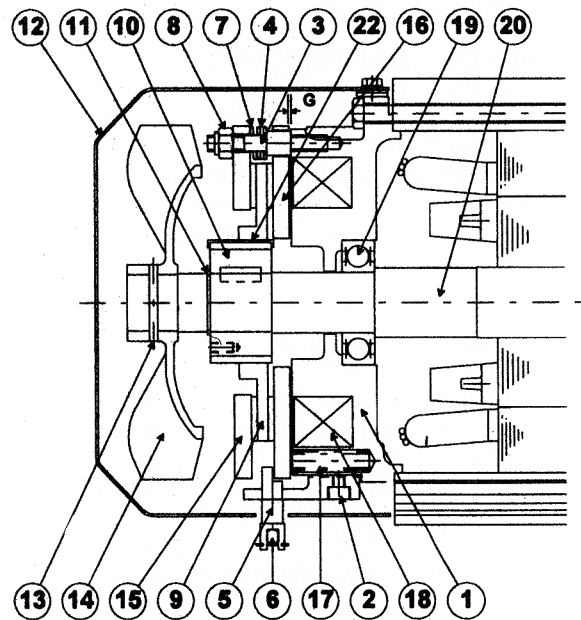


Fig. C-5 FB-5B, FB-8B Models

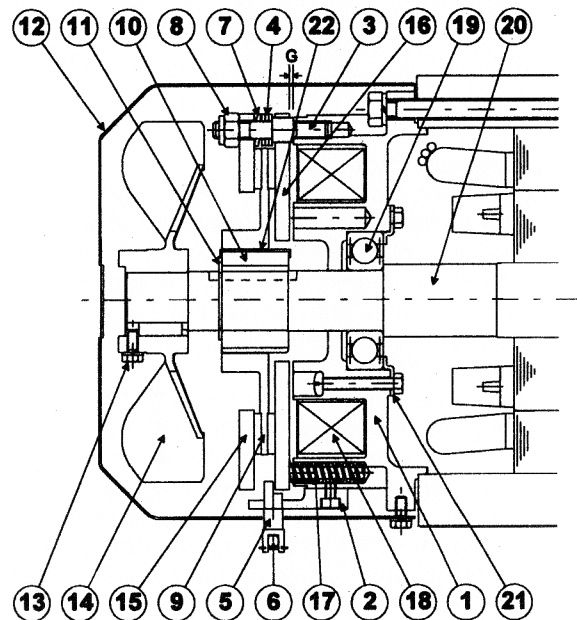
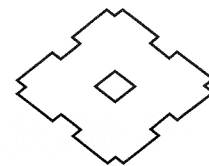


Fig. C-6 FB-10B, FB-15B Models

### Manual brake release procedure

To manually release the brake with power to the unit off, use the brake release mechanism as follows: FB-5B, -8B, -10B, and -15B brakemotors are equipped with a one-touch release mechanism. To disengage brake, pull out the brake release lever from its holder and push it forward toward the reducer. Releasing the lever will re-engage the brake.



## Models FB-5B, -8B, -15B (cont.)

### Gap Inspection and Adjustment

The brake lining will wear after the unit has been used for a long period of time. It is necessary to check the brake for gap G from time to time (Figs. C-5 and C-6). Should gap G become too large, the solenoid coil may fail to pull in the armature plate and hence cannot release the brake, resulting in the unit remaining in a continuously braked condition.

### Gap Inspection Procedure

1. Remove fan cover (12).
2. Insert a gap gage into the gap between stationary core (1) and armature plate (16), and measure the size of the gap. Adjustment is needed if the measured value is close to the allowable limit shown in Table C-9. Gap measurement should be made at three appropriate circumferential points.

**Table C-9. Brake Gap Size**

Brake Type	Gap value G (in)	
	Spec. value	Allowable limit
FB-5B	0.016 ~ 0.020	0.039
FB-8B	0.016 ~ 0.020	0.039
FB-10B	0.016 ~ 0.020	0.047
FB-15B	0.016 ~ 0.020	0.047

### Gap Adjustment Procedure

**If the brake lining is so heavily worn that gap adjustment is required, proceed as follows:**

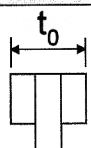
1. Remove fan cover (12).
2. Insert a gap gage into the gap between stationary core (1) and armature plate (16), and rotate the nut (8) at the tip of the stud bolt (3) clockwise until appropriate size is reached. Should gap be too large for this adjustment, decrease the number of adjusting washers in use. The three nuts (8) should be evenly adjusted by turns until the gaps at the three circumferential points are equal in width and fall within specification range shown in Table C-9.
3. Check for brake performance by turning system power on and off a few times.
4. Replace fan (14), set pin or screw (13) and cover (12).

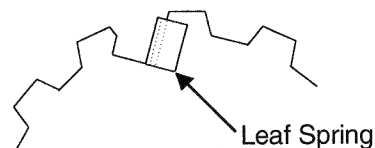
### Brake lining replacement

When the brake lining has been worn to such a degree that its thickness has reached the allowable limit shown in Table C-10, replace the brake lining with a new one as follows:

1. Remove fan cover (12).
2. For models FB-5B and -8B remove set pin (13) and fan (14). For models FB-10B and -15B remove set screw (13) and fan (14).
3. Remove all three nuts (8).
4. Remove brake shoe (15) and take out brake lining (9).
5. Fix leaf spring (22) as shown in Fig. C-7.
6. Apply a small amount of grease along the spline of the lining. Be careful not to apply grease to the wear surface.
7. Fit a new brake lining (9) onto hub (10); check to ensure that the lining moves smoothly. Remove excess grease.
8. After completion of brake assembly, measure gap G. If the gap is out of specification range, adjust by rotating gap adjusting nut (8).
9. Check for brake performance by turning system power on and off a few times. If no abnormalities are detected, replace fan (14), set pin or screw (13) and cover (12).

**Table C-10. Brake Lining Size**

Brake Type	Brake lining dimension	Initial thickness $t_0$ (in)	Allowable thickness limit $t_0$ (in)
FB-5B		0.394	0.237
FB-8B		0.394	0.237
FB-10B		0.433	0.276
FB-15B		0.433	0.276

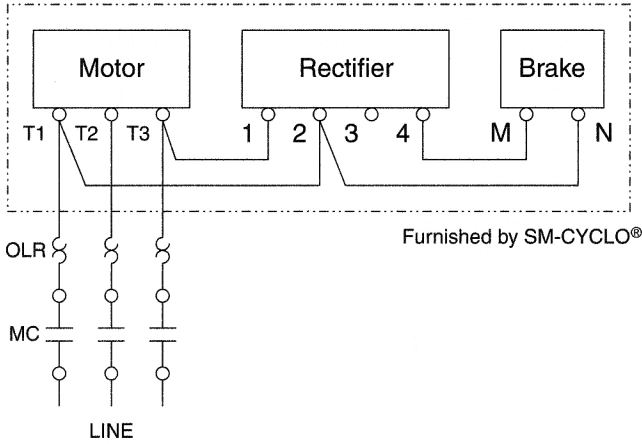


**Fig. C-7**

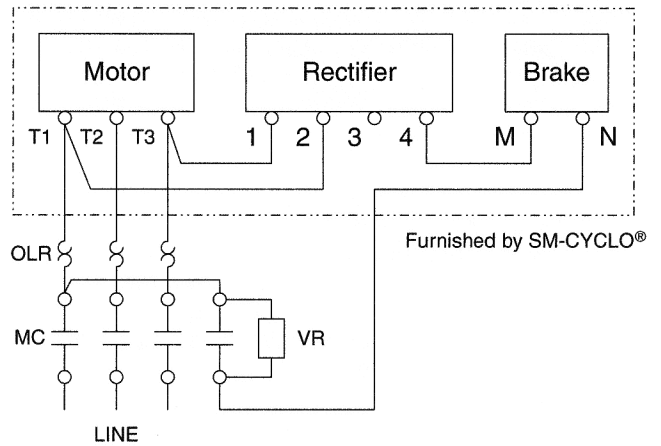
# FB MODELS – WIRING DIAGRAMS

## Standard Wiring Connection, Dual Voltage

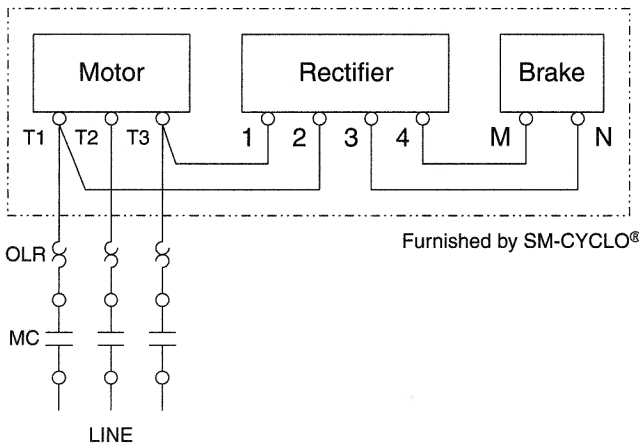
**Fig. C-8a Normal Brake Action, High Voltage**



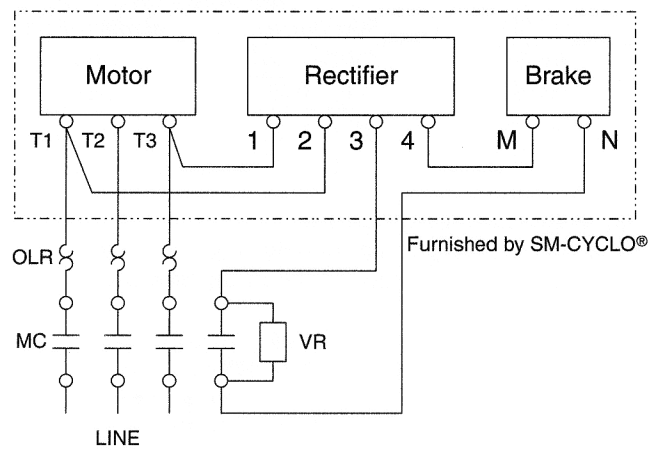
**Fig. C-8b Fast Brake Action, High Voltage**



**Fig. C-8c Normal Brake Action, Low Voltage**

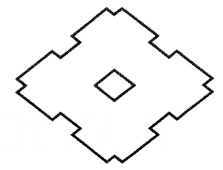


**Fig. C-8d Fast Brake Action, Low Voltage**



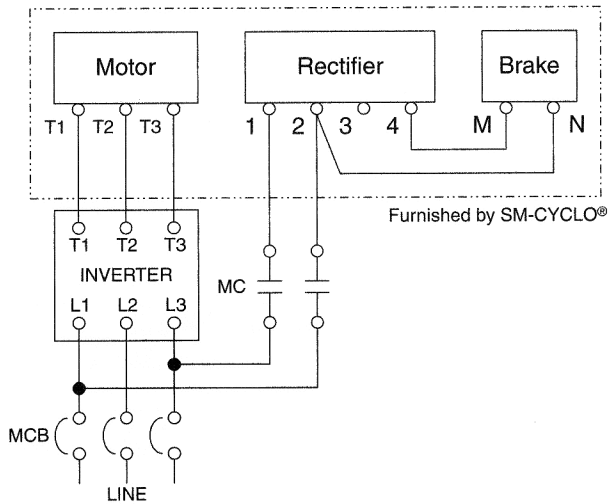
- MC: Electromagnetic contactor
- MCB: Magnetic Circuit Breaker
- OLR: Overload or thermal relay
- VR: Varistor (protective device)

Recommended brake contactor size for fast acting circuit is greater than 5 times rated current shown in Table C-2 on page C-4.

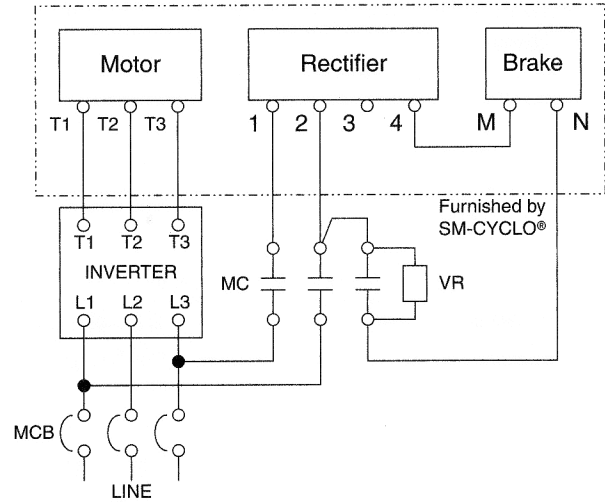


## Inverter Wiring Connection, Dual Voltage

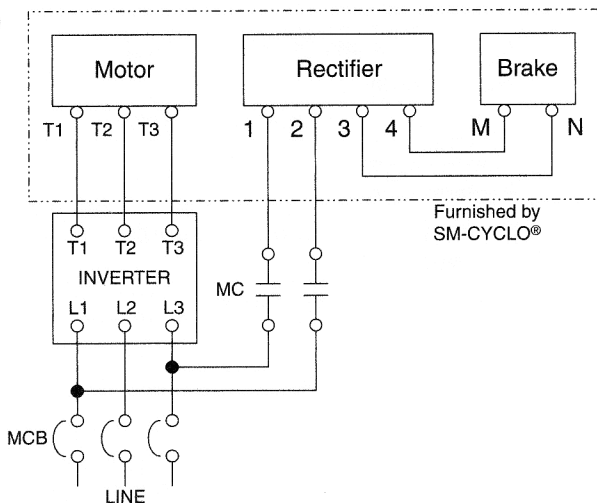
**Fig. C-9a Normal Brake Action, High Voltage**



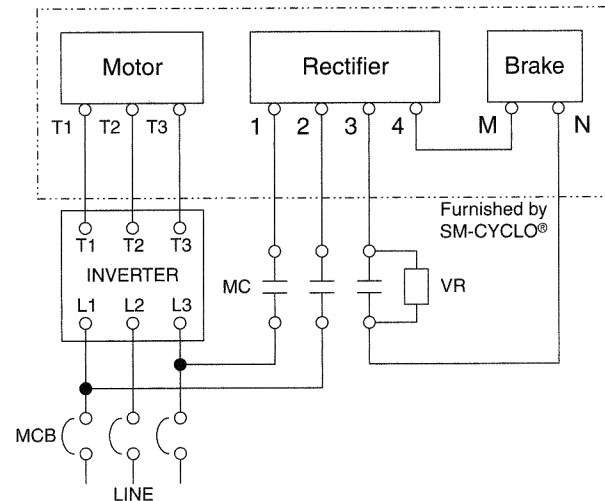
**Fig. C-9b Fast Brake Action, High Voltage**



**Fig. C-9c Normal Brake Action, Low Voltage**



**Fig. C-9d Fast Brake Action, Low Voltage**



- MC: Electromagnetic contactor
- MCB: Magnetic Circuit Breaker
- OLR: Overload or thermal relay
- VR: Varistor (protective device)

Recommended brake contactor size for fast acting circuit is greater than 5 times rated current shown in Table C-2 on page C-4.

**Table C-11. Varistor Specifications**

Operating Voltage		200-230V	380-460V
Var. Rated Voltage		AC260-300V	AC510V
Varistor Voltage		430-470V	820V
Rated Watt	FB-01A, 02A	Over 0.2W	Over 0.4W
	FB-05A	Over 0.2W	Over 0.4W
	FB-1B	Over 0.4W	Over 0.6W
	FB-2B, -3B	Over 0.6W	Over 1.5W
	FB-5B, -8B	Over 0.6W	Over 1.5W
	FB-10B, -15B	Over 1.0W	Over 1.5W

# FB MODELS – TROUBLESHOOTING

## Troubleshooting

The brake is normal when it meets the following criteria:

- a) The motor begins to run immediately after the start switch is pressed to ON.
- b) No abnormal sounds are heard from the unit in operation.
- c) The motor stops running within about 0.5 second after power to the unit is switched off.

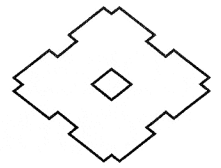
Should you find any abnormality, refer to Table C-12 below and take the appropriate corrective action as soon as possible.

**Table C-12. Quick Troubleshooting Guide**

Problem	Possible Cause	Corrective Action
Gap cannot be set to spec. value	Brake lining wear is too great	Reduce the number of gap adjusting washers
Brake fails to operate	Release lever still engaged	Disengage and lock lever in holder
	Improper adjustment after reassembly	Adjust again
Brake slips (braking time is too long)	Not wired for fast action	Wire for fast action
	Varistor failed	Replace Varistor
	Foreign matter entrapped in brake lining Oil on lining surface	Remove foreign matter and take preventive action. Wipe lining surface with dry cloth
	Worn brake lining	Adjust brake gap or replace lining
	Uneven brake gap	Adjust evenly
	Excessive load	Decrease load or use larger brake
Rotor fails to turn	Faulty electric circuit	Check circuit
	Blown fuse	Replace fuse
	Only single phase available from three phase power supply	Measure power supply voltage and check for defective circuit
	Protective device has tripped	Eliminate cause and reset
	Damaged or burned motor winding	Repair or replace
	Rust on brake friction surface	Clean brake (lining)
	Gap needs adjustment	Readjust gap
	Burned bearing	Replace
	Overload	Check and troubleshoot load and safety device
Abnormal noise	Foreign material inside the brakemotor	Check inside and remove
	Damaged bearing	Replace
	Worn brake lining	Adjust brake gap or replace lining
	Hub leaf spring is off or damaged	Replace
	Burned solenoid coil	Replace
	Damaged rectifier	Replace
Trouble under loaded condition	Voltage drop	Raise voltage to rated level
	Overload	Reduce the load or oversize the brakemotor
	Improper protective device setting	Adjust protective device



# MODEL CMB-20 – CONSTRUCTION, OPERATION, WIRING



## Construction and Operating Principles

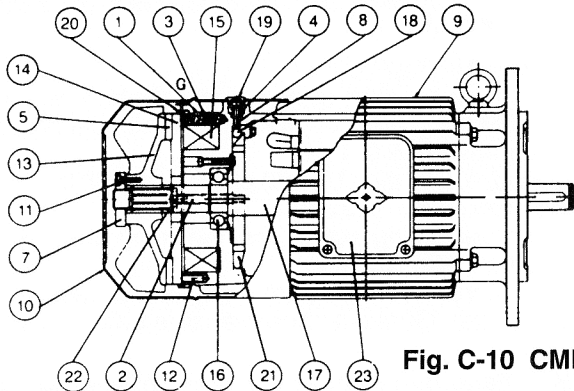


Fig. C-10 CMB-20 Model

Table C-13. CMB-20 Parts

No.	Part Name	No.	Part Name
1	Stationary Core*	13	Brake Wheel*
2	Restraining Bolt*	14	Armature Plate*
3	Pressure Spring*	15	Solenoid Coil*
4	Auxiliary Spring	16	Bearing
5	Brake Lining*	17	Motor Shaft
7	Restraining Nut*	18	Roller*
8	Adjusting Bolt (Not Supplied)	19	Plug*
9	Motor	20	Dust Proof Seal*
10	Fan Cover	21	Shifting Plate*
11	Bolt*	22	Nut*
12	Pin*	23	Conduit Box

\*These parts are included in a complete brake kit.

## Construction

Each brake consists of a solenoid coil (15), armature plate (14), and brake lining (5). The armature plate (14) is free to move axially along the motor shaft (17), but is restrained from rotation by a pin (12). A pressure spring (3) forces the armature plate (14) against the brake wheel (13), which is fixed to the motor shaft (17). The restraining nut (7) restrains the brake wheel against axial motion when braking.

A threaded stud passes through the armature plate (14) and stationary core (1), threading into the shifting plate (21). A nut (22) is installed on one end of the stud.

The brake includes an air gap adjustment mechanism that consists of a roller (18), adjusting bolt (8), auxiliary spring (4), and shifting plate (21).

## Operating Principles

When power is applied, the current flows through the solenoid coil, an electromagnetic force attracts the armature plate — overcomes spring forces — the brake disengages and the motor shaft begins to rotate.

When the power is removed, the current flow through the solenoid coil stops and the electromagnetic force decays. The spring (3) force now moves the armature plate (14) toward the brake wheel (13) pressing the brake lining (5) against the brake wheel and the motor shaft quickly comes to a stop.

## Wiring Connection

NOTE: For single voltage brakemotor 208V, 230V, 460V, 575V, or other special voltages, please refer to the motor mounted connection diagram or refer to the factory.

### Normal Brake Action

Fig. C-11a Low Voltage 200 ~ 230V

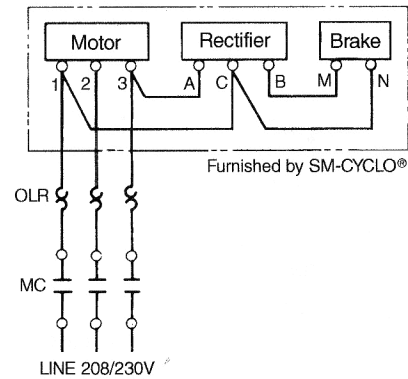
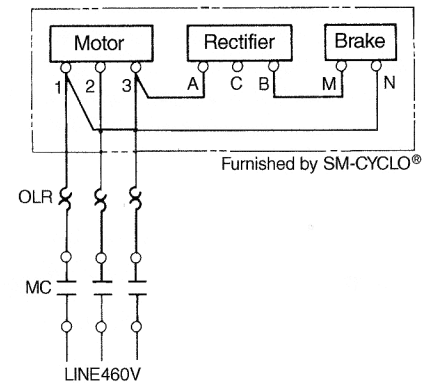
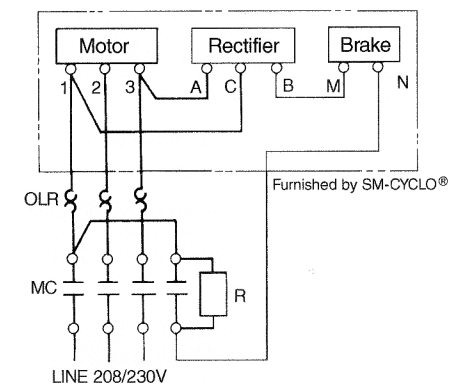


Fig. C-11b High Voltage 400 ~ 460V



### Fast Brake Action

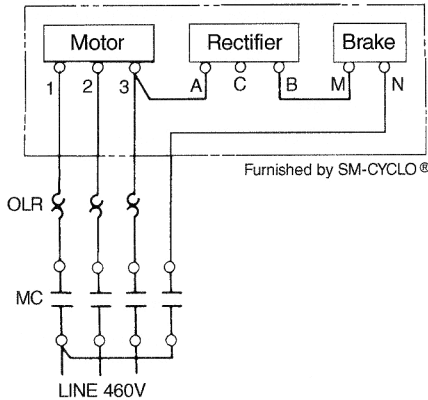
Fig. C-11c Low Voltage 200 ~ 230V



OLR: Overload or thermal relay  
 MC: Electromagnetic contactor  
 R: Resistor (2 watt, 200~300Ω)

# MODEL CMB-20 – WIRING, MAINTENANCE, TROUBLESHOOTING

Fig. C-11d High Voltage 400 ~ 460



## Adjustment and Maintenance

### Brake Lining Inspection

If the brake has been in operation for a long period of time and then starts to operate improperly, check the brake lining for wear. Under normal use the lining will wear after approximately 200,000 engagements.

### Inspection of Air Gap "G"

The air gap "G" will increase as the brake lining wears. It must not exceed .050 inch, or difficulty may be experienced. To check the air gap, proceed as follows:

1. remove the plug (19), cover (10) and the dust proof seal (20).

2. insert a feeler gage between the stationary core and the armature plate. If air gap exceeds .050 inch, adjust the gap as follows:

### Adjustment of Air Gap "G"

1. remove the two bolts (2) using a socket head wrench.
2. install an M8 thread by 30mm long brake adjusting bolt at position #8 Figure C-10.
3. turn the brake adjusting bolt (8) clockwise until the brake is completely released.
4. tighten the restraining nut (7) until the lining (5) nearly contacts the brake wheel.
5. remove the brake adjusting bolts installed in step 4 above. Air Gap "G" should now measure 0.030 inch or less.

**DANGER — Failure to remove the brake adjusting bolt will result in an inoperative brake.**

6. install bolts (2) and tighten.
7. install dust proof seal (20), cover (10), and plug (19).
8. test brakemotor a few times to insure proper operation.

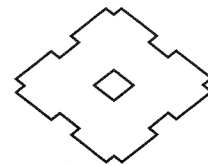
### Troubleshooting

The brake is normal when it meets the following criteria:

1. The motor begins to run immediately after the start switch is pressed to ON.
2. No abnormal sounds are heard from the unit in operation.
3. The motor stops running within approx. 1.5 seconds after the power to the unit is switched off. Should you find any abnormality, refer to Table C-14 below and take the appropriate corrective action as soon as possible.

Table C-14. Quick Troubleshooting Guide (For Model CMB-20)

Problem	Possible Cause	Corrective Action
Brake inoperative	Brake lining excessively worn	Inspect as described in <b>Inspection of Air Gap "G"</b>
	Improperly serviced after assembly	Reservice
Motor does not rotate when power is applied	Air gap G excessively increased	Adjust gap G as described in <b>Adjustment of Air Gap "G"</b>
	Electromagnetic coil opened	Repair it at service shop
	Rectifier damaged	Replace it
	Wiring failure	Wire correctly
	Voltage drop	Contact SUMITOMO
	Retaining nut overtightened in serving	Readjust
Long braking time	Spring overtensioned	Pressure spring correctly
	Fast action circuit not used	Change to fast action (refer to <b>Wiring Connection</b> pg. C-13)
	Air gap G excessive; friction disc comes in contact with nut	Adjust gap G as described in <b>Adjustment of Air Gap "G"</b>
Brake cannot operate continuously due to reset mechanism	Insufficient brake torque	Adjust spring compression
	Restraining nut overtightened	Readjust as described in <b>Adjustment of Air Gap "G"</b>
	Motor protection device improperly adjusted	Reset bolt



## SM-CYCLO 4000 – 6000 SERIES INTERCHANGE TABLE

SINGLE REDUCTION	
4000	6000
–	6060
4075	6065
–	6070
4085	6075
–	6080
–	6085
4090	6090
4095	6095
4097	–
4100	6100
4105	6105
410H	610H
–	6110
–	6115
4110	6120
4115	6125
4125	612H
4130	6130
4135	6135
–	6140
4145	6145
4155	614H
4160	6160
4165	6165
416H	616H
4170	6170
4175	6175
4180	6180
4185	6185
4190	6190
4195	6195
4205	6205
4215	6215
4225	6225
4235	6235
4245	6245
4255	6255
4265	6265
4275	6275

DOUBLE	
4000	6000
–	6060DA
4075DA	6065DA
–	6070DA
4085DA	6075DA
4090DA	6090DA
4095DA	6095DA
4097DA	–
4100DA	6100DA
4105DA	6105DA
4110DA	6120DA
4110DB	6120DB
4115DA	6125DA
4115DB	6125DB
4130DA	6130DA
4130DB	6130DB
4130DC	6130DC
4135DA	6135DA
4135DB	6135DB
4135DC	6135DC
–	6140DA
–	6140DB
–	6140DC
4145DA	6145DA
4145DB	6145DB
4145DC	6145DC
4160DA	6160DA
4160DB	6160DB
4160DC	6160DC
4165DA	6165DA
4165DB	6165DB
4165DC	6165DC
4170DA	6170DA
4170DB	6170DB
4170DC	6170DC
4175DA	6175DA
4175DB	6175DB
4175DC	6175DC
4180DA	6180DA
4180DB	6180DB
4185DA	6185DA
4185DB	6185DB
4190DA	6190DA
4190DB	6190DB
4195DA	6195DA
4195DB	6195DB
4205DA	6205DA
4205DB	6205DB
4215DA	6215DA
4215DB	6215DB
4225DA	6225DA
4225DB	6225DB
4235DA	6235DA
4235DB	6235DB
4245DA	6245DA
4245DB	6245DB
4255DA	6255DA
4255DB	6255DB
4265DA	6265DA
4275DA	6275DA

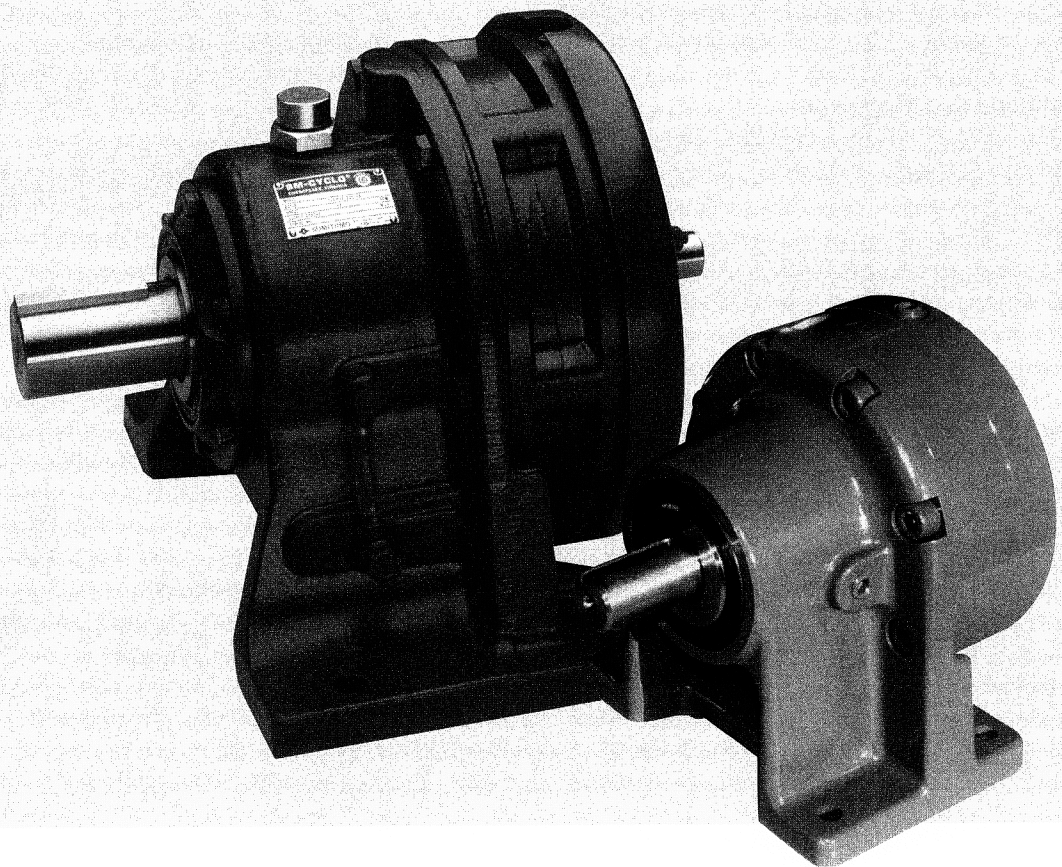
TRIPLE REDUCTION			
4000		6000	
–	6060TA	4190TA	6190TA
4075TA	6065TA	4190TB	6190TB
–	6070TA	4190TC	6190TC
4085TA	6075TA	4190TD	6190TD
–	6090TA	4190TE	6190TE
4095TA	6095TA	4195TA	6195TA
–	6100TA	4195TB	6195TB
4105TA	6105TA	4195TC	6195TC
–	6120TA	4195TD	6195TD
–	6120TB	4195TE	6195TE
4115TA	6125TA	4205TA	6205TA
4115TB	6125TB	4205TB	6205TB
4130TA	6130TA	4205TC	6205TC
4130TB	6130TB	4205TD	6205TD
4130TC	6130TC	4205TE	6205TE
4135TA	6135TA	4215TA	6215TA
4135TB	6135TB	4215TB	6215TB
4135TC	6135TC	4215TC	6215TC
–	6140TA	4215TD	6215TD
–	6140TB	4215TE	6215TE
–	6140TC	4215TF	6215TF
4145TA	6145TA	4225TA	6225TA
4145TB	6145TB	4225TB	6225TB
4145TC	6145TC	4225TC	6225TC
4160TA	6160TA	4225TD	6225TD
4160TB	6160TB	4225TE	6225TE
4160TC	6160TC	4225TF	6225TF
4160TD	6160TD	4235TA	6235TA
4165TA	6165TA	4235TB	6235TB
4165TB	6165TB	4235TC	6235TC
4165TC	6165TC	4235TD	6235TD
4165TD	6165TD	4235TE	6235TE
4170TA	6170TA	4245TA	6245TA
4170TB	6170TB	4245TB	6245TB
4170TC	6170TC	4245TC	6245TC
4170TD	6170TD	4245TD	6245TD
4175TA	6175TA	4245TE	6245TE
4175TB	6175TB	4255TA	6255TA
4175TC	6175TC	4255TB	6255TB
4175TD	6175TD	4255TC	6255TC
4180TA	6180TA	4255TD	6255TD
4180TB	6180TB	4255TE	6255TE
4180TC	6180TC	4265TA	6265TA
4180TD	6180TD	4265TB	6265TB
4185TA	6185TA	4275TA	6275TA
4185TB	6185TB	275TB	6275TB
4185TC	6185TC		
4185TD	6185TD		

# Notes

---

---

# APPENDIX



# APPENDIX CONTENTS

Grease Quantities for Units Having Optional Grease Lubrication . . . . . D-2  
 Food-Grade Lubricants. . . . . D-3

## Grease Quantities for Units Having Optional Grease Lubrication

In the case where a unit that is normally oil-lubricated is supplied with grease lubrication, use the values in Table D-1 and the type of grease in Table D-2 to replenish the grease in the selected unit.

**Table D-1: Grease Quantities for Normally Oil Lubricated Units**

Frame Size	6130 6135 6140 6145	6160 6165	6170 6175	6180 6185	6190 6195	6215	6225	6235	6245	6255	6265
Speed Reduction Mechanism	15.9 (450)	26.5 (750)	35.3 (1000)	36.8 (1100)	52.9 (1500)	70.5 (2000)	88.2 (2500)	141.1 (4000)	158.7 (4500)	211.6 (6000)	282.2 (8000)
Slow Speed Shaft Bearing	10.6 (300)	10.6 (300)	17.6 (500)	21.2 (600)	24.7 (700)	28.2 (800)	31.7 (900)	35.3 (1000)	36.8 (1100)	42.3 (1200)	45.9 (1300)

**Table D-2: Standard Grease for Normally Oil Lubricated Units**

Frame Size	Ambient Temperature		Planetary	Cycloid Discs
	°F	°C		
613 to 616	14 to 122	-10 to 50	Shell Gadus S2 V220 0 (613X to 617X)	Exxon Unirex N2
617 to 626				Shell Gadus S2 V220 2

**Note:** For double and triple reduction units, standard grease is Exxon Unirex N2

# Food-Grade Lubricants

Sumitomo prefills units with state of the art, synthetic NSF H-1 lubricants. These lubricants are suitable for incidental food contact. They also provide higher efficiency and longer life in a wide variety of conditions. In the case where a unit is supplied with Food-Grade lubrication, use the values in Table D-3.

**Table D-3: Food-Grade Lubricants**

Frame Size	Type	Factory Fill
606	PAO Grease	Omnilube FGM-2
607		
608		
609		
610		
611		
612	PAG Oil	Kluber UH1 6-460
613		
614		
616		

Cyclo sizes 613 through 616 are available with PAG oil lubrication only.

# Sumitomo Machinery Corporation of America

## Headquarters & Manufacturing

4200 Holland Boulevard  
Chesapeake, VA 23323  
Tel: 757-485-3355 • 1-800-SMCYCLO  
Fax: 757-485-7490

www.sumitomodrive.com  
E-mail: customercare@suminet.com



***[www.sumitomodrive.com/Cyclo6000](http://www.sumitomodrive.com/Cyclo6000)***

### World Headquarters

Japan  
Sumitomo Heavy Industries, Ltd.  
Power Transmission & Controls Group  
ThinkPark Tower, 1-1, Osaki 2-chome,  
Shinagawa-ku, Tokyo 141-6025 Japan  
Tel: +81-36-737-2511 • Fax: +81-36-866-5160

*For facilities located in the Americas, please visit  
[www.sumitomodrive.com/locations](http://www.sumitomodrive.com/locations)*

*For worldwide locations, please visit  
[www.sumitomodrive.com/worldwide](http://www.sumitomodrive.com/worldwide)*