

Cyclo[®] BBB4 Bevel Buddybox[®]

Right Angle Spiral Bevel Gearbox
with Cyclo[®] Reducer Input

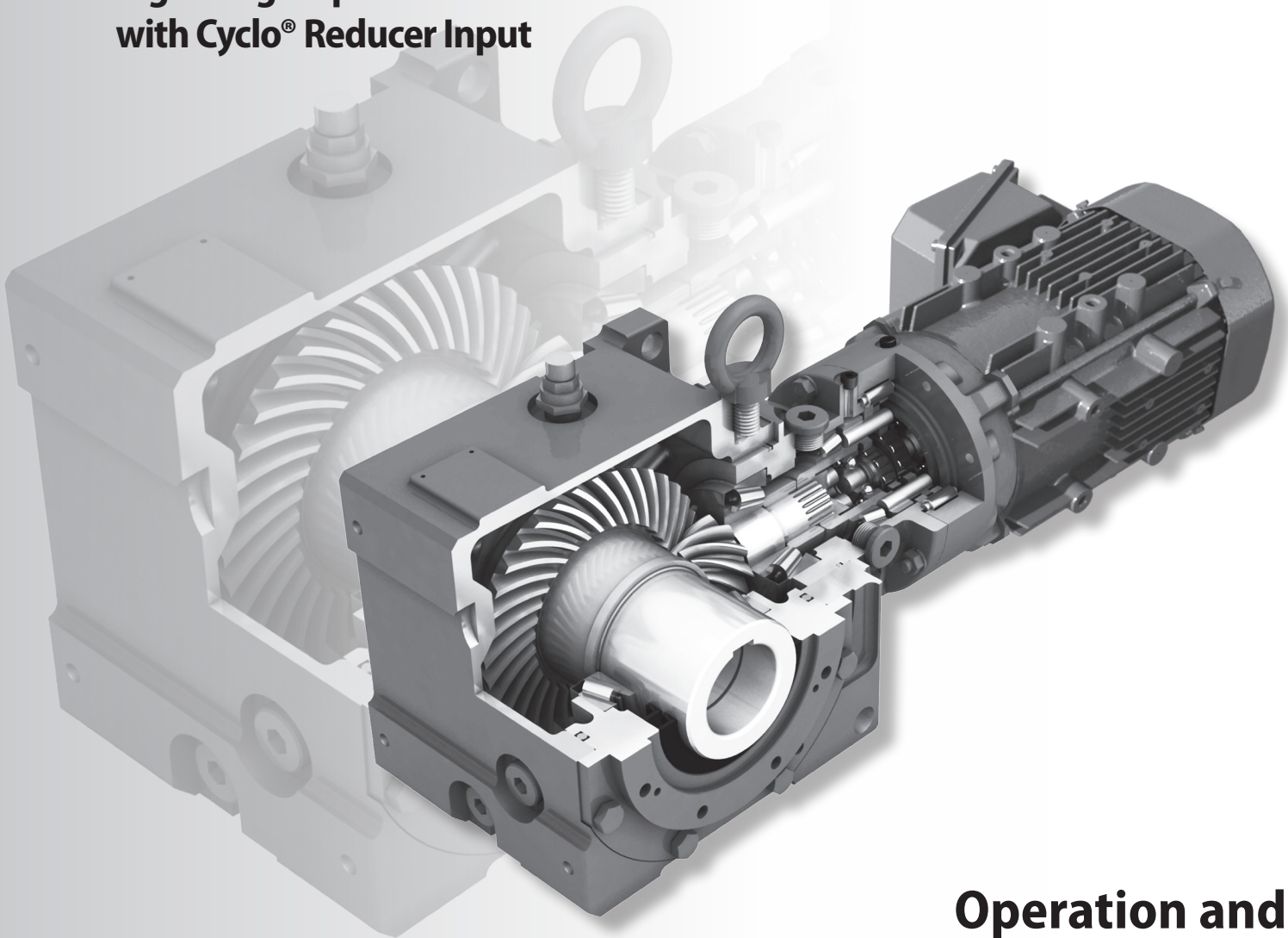

Operation and Maintenance Manual

Table of Contents

Important Notes	2	Motor Wiring Method	42
Safety Symbols	2	Brake Wiring.	43
Safety Precautions	2	Varistor Selection	43
Disposal	2	U.S. Standard and CSA Approved Motor Brake Wiring	44
Delivery	3	CE Motor Brake Wiring	46
Inspection Upon Delivery	3	Brake Rectifiers and Power Modules	48
Nameplate Inspection	3	Parts	49
Lubrication Inspection	3	Cyclo® BBB4 Reducer Parts	49
Nomenclature	4	Cyclo® Planetary Reduction Component Parts	
Storing and Transporting	6	(Cyclo® Ratios 11 – 18:1)	50
Storage Location	6	Cyclo® Reduction Component Parts	
Storage Period	6	(Cyclo® Ratios ≥ 19:1)	51
Operation After Storage	6	Bearings and Oil Seals.	53
Transporting	6	Bevel Gearing Parts and Tooth Count	54
Installation Notes	7	Cyclo® BBB4 Screw Conveyor Options.	55
Installation Precautions.	7	Screw Conveyor Components	55
Installation Location.	7	Screw Conveyor Assembly Instructions	55
Installation Angle	7	Cyclo® Portion Disassembly/Assembly	58
Severe Loading Conditions	7	Cyclo® Portion - General Disassembly	58
Installation onto the Driven Machine	7	Cyclo® Portion - General Reassembly	62
Installation onto Driven Shaft	8	Troubleshooting	64
Taper-Grip® Bushing.	8	Reducer Troubleshooting	64
Keyed Hollow Bore.	12	Motor Troubleshooting	65
Shrink Disc Type Hollow Bore	13		
Torque Arm Installation	16		
Torque Arm Introduction	16		
Turnbuckle Type Torque Arm	16		
Tie Rod Type Torque Arm	18		
Flange Mount (Banjo) Type Torque Arm.	20		
T-Type Torque Arm.	22		
Removal from Driven Shaft	24		
Cyclo® BBB4 with Taper-Grip® Bushing	24		
Cyclo® BBB4 with Keyed Hollow Bore	25		
Cyclo® BBB4 with Shrink Disc	26		
Lubrication	27		
Taconite Seal Lubrication Procedure	27		
Lubrication Introduction	29		
Lubrication Nomenclature	29		
Lubrication Method	30		
Bevel Gear Portion and Cyclo® Portion Recommended Oils	31		
Cyclo® Portion Recommended Greases	31		
Oil Quantities	32		
Oil Supply Procedure	34		
Oil Discharge Procedure	34		
Grease Quantities	35		
Grease Replenishment and Draining Procedures	36		
Grease Replacement	36		
Y2 Oil Fill & Drain Procedures	37		
Motor Wiring	41		
Wiring Guidelines	41		
Measuring Insulation Resistance	41		
Motor Protection.	42		

Important Notes

Safety Symbols

These safety symbols appear throughout this manual to indicate important warnings:



DANGER: Incorrect handling of the unit and/or failure to follow the instructions may cause physical damage, serious personal injury, and/or death.



CAUTION: Incorrect handling of the unit and/or failure to follow the instructions may cause physical damage and/or personal injury.

Safety Precautions

Review and adhere to the instructions in this manual to ensure:

- trouble-free Cyclo® BBB4 operation
- your rights to make a warranty claim.

Read this manual and all accompanying documents thoroughly before use. Understand the machine, information on safety, and all precautions for correct operation. Sumitomo recommends making this manual easily accessible for reference at the machine location.



- **Only properly trained personnel** should transport, install, align, wire, inspect, operate, and maintain the unit.
- When the unit is to be used in a system for transport of human beings, a secondary safety device should be installed to guard against accidents that may result in injury, death, or damage to the system.
- When the unit is to be used for an elevator, install a safety device on the elevator side to prevent it from falling; otherwise, serious injury, death, or damage to the elevator may result.



CAUTION:

- Operate the unit only within its design and performance specifications; otherwise, injury or damage to the system may occur.
- Keep hands and all foreign objects from the internal moving parts of the unit; otherwise, injury or damage to the system may occur.
- Take damaged units off-line immediately and do not resume operation until properly repaired.
- Modifications or alterations of any kind to the unit will void the warranty and all subsequent claims.
- Do not remove the rating plate.

Disposal

Please refer to local, state, and federal regulations governing disposal of:

Steel Scrap:

- Housing (Ductile and Gray Cast Iron)
- Gears
- Shafts
- Bearings

Lubricants:

- Gear Oil
- Grease

Inspection Upon Delivery



- In order to avoid injury, **ensure that the unit is in a stable position** before unpacking.
- **Verify that the unit received matches your order.** Using the incorrect product may cause equipment damage or personal injury.
- **Do not** remove the nameplate from the unit.

Upon delivery, inspect the unit for damage that may have occurred during shipment. Notify the shipping company immediately if you find any damage. **Do not** install or operate a damaged unit.

Upon receipt of the reducer/gearmotor, verify that:

- the model number on the unit nameplate matches the purchase order
- the unit was not damaged during shipping
- all bolts and nuts are fully tightened.

Please consult your Sumitomo agent, distributor, or sales office if you find any defects or if you have any questions.

Nameplate Inspection

When contacting Sumitomo about this product, please be prepared to provide the following information from the reducer/gearmotor nameplate:

- **reducer or gearmotor model number (nomenclature)**
- **reduction ratio**
- **serial number.**

Lubrication Inspection



- **Oil lubricated units are shipped without oil, unless the customer specified otherwise when the unit was ordered.** Always fill the unit with the correct type and quantity of lubricant prior to operation.
- **Certain models must be filled with lubricant in two separate locations,** the Bevel Gear portion (output) and the input portion.

Refer to the lubrication section in this manual for detailed lubrication information.

Metal Reducer Nameplate

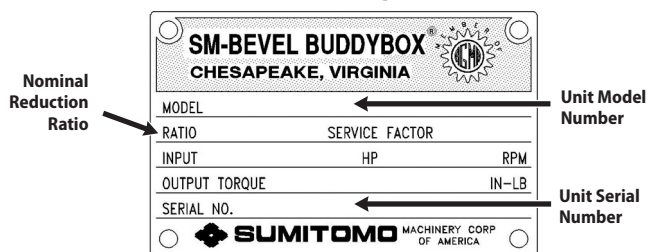

Non-Metallic Nameplate (when Cyclo input is 613 or larger)

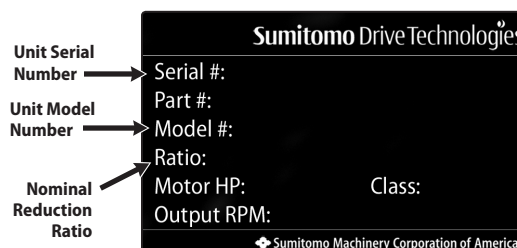

Metal Gearmotor Nameplate

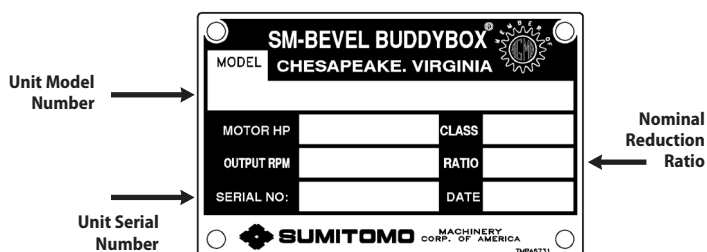

Non-Metallic Nameplate (when Cyclo Input is 6120 or smaller)

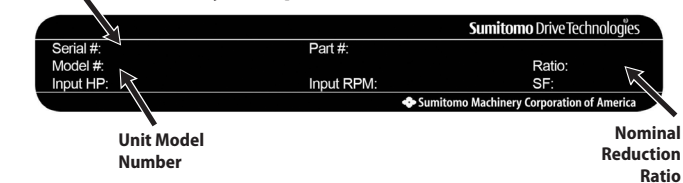

Nomenclature

Nomenclature

Our nomenclature details specific information about our products. Verify that the nomenclature of the unit delivered matches your order.

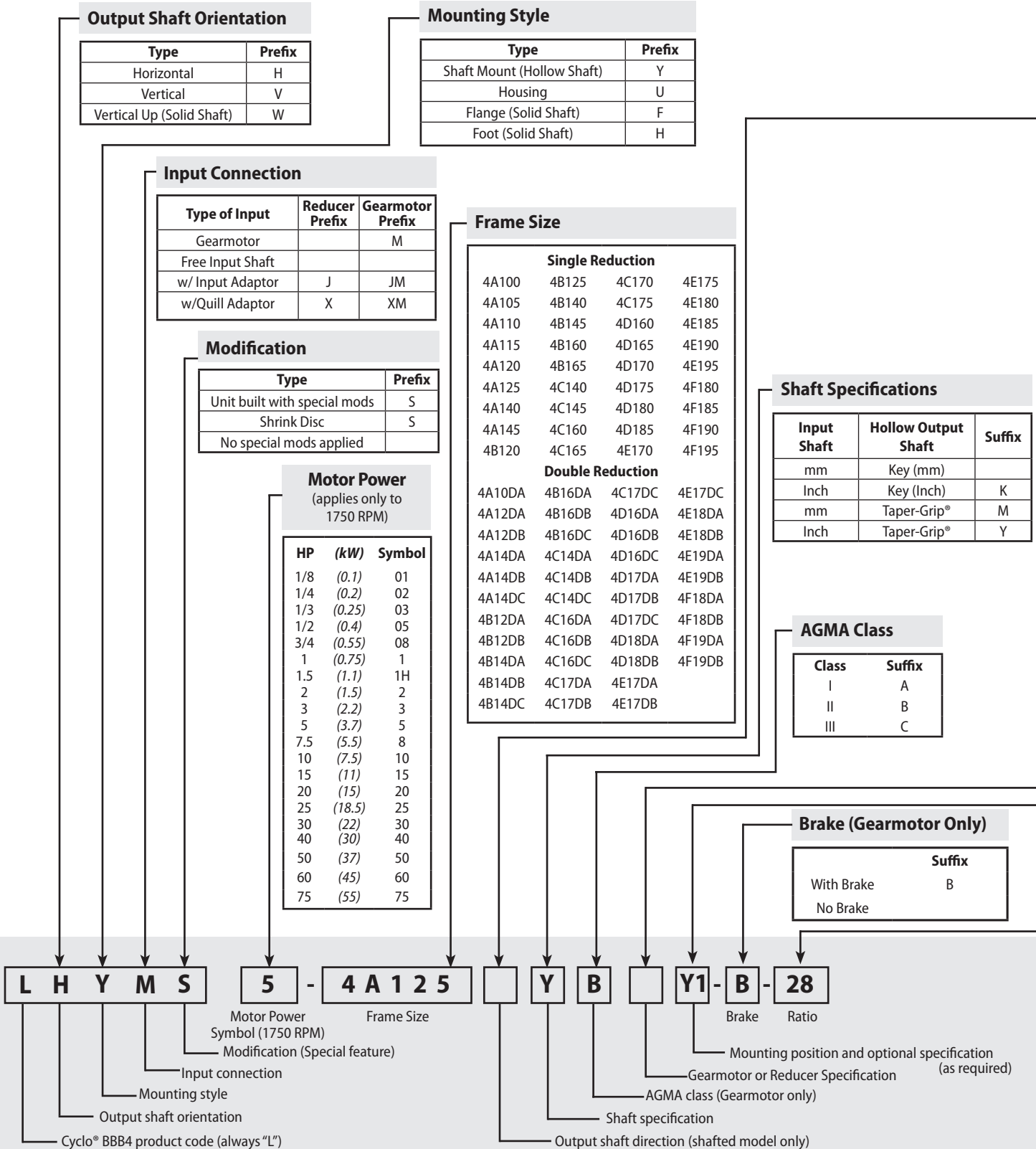

Nomenclature, continued

Output Shaft Direction (shafted model only)

Projects to Left Side	L	
Projects to Right Side	R	
Projects to Both Left/Right Sides	T	

Gearmotor Specification

Specification	Suffix
Three-Phase Motor	
Single-Phase Motor	SG
AF Motor (Adj. Frequency)	AV
Servo Motor	SV
DC Motor	DV
Torque Limiter	TL

Reducer Specification

Type	Suffix
Standard	
Baseplate	BP
Shovel Base	SB
DC Motor	DV

Mounting Positions

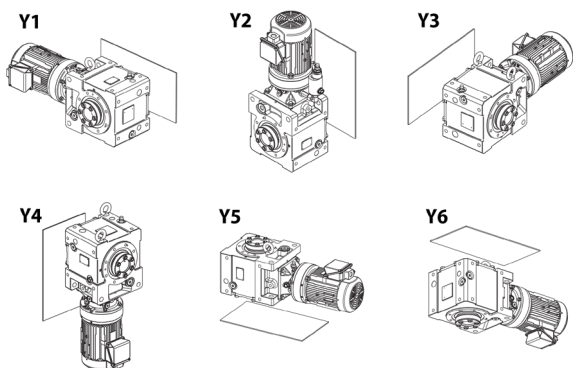

Nomenclature Example: LHYMS-5-4A125-YB1-B-28

- | | |
|--------------------------------|-------------------------------------|
| L - Cyclo® Bevel Buddybox | 4A125 - Frame Size |
| H - Horizontal | Y - Inch Shaft Specification |
| Y - Shaft Mount (Hollow Shaft) | B - AGMA Class |
| M - Gearmotor | Y1 - Mounting Position |
| S - Special Modifications | B - Brake (gearmotor only) |
| 5 - 5 HP (3.7kW), 1750 RPM | 28 - Ratio |

Nominal and Exact Ratio

BBB with Planetary Input				BBB with Cyclo Input			
Nominal Ratio		Frame Size	Exact Ratio	Single Reduction			
Input	Overall			Nominal Ratio		Frame Size	Exact Ratio
				Input	Overall		
3	11	4A10	10.50	All	6	21	21.0
		4A12	10.89		7	22	22.4
		4A14	10.85		8	25	24.5
		4B14	10.85		11	28	28.0
		4B16	10.50		13	35	35.2
		4C16	10.50		15	39	38.5
		4D16	10.82		17	46	45.5
		4D17	10.82		21	53	52.5
		4E17	10.82		25	60	59.5
		4E18	10.82		29	67	67.2
		4F18	10.82		35	74	73.5
		4F19	10.82		41	80	80.0
4	13	4A10	12.99	All	25	88	87.5
		4A12	12.80		29	102	101.5
		4A14	12.95		35	112	112.0
		4B14	12.80		43	123	122.5
		4B16	12.80		51	151	150.5
		4C16	13.09		59	179	178.5
		4D16	13.09		71	207	206.5
		4D17	13.09		87	249	248.5
		4E17	13.01		119	305	304.5
		4E18	13.01		147	351	350.5
		4F18	13.01		175	417	416.5
		4F19	13.01		213	477	476.5
5	14	4A10	14.21	All	104	364	364.0
		4A12	14.00		121	424	423.5
		4A14	14.16		143	501	500.5
		4B14	14.16		165	578	577.5
		4B16	14.00		195	683	682.5
		4C16	14.00		231	809	808.5
		4D16	14.32		273	956	955.5
		4D17	14.32		319	1117	1116.5
		4E17	14.32		377	1320	1319.5
		4E18	14.23		473	1656	1655.5
		4F18	14.23		559	1957	1956.5
		4F19	14.23		649	2272	2271.5
5	16	4A10	15.36	All	731	2559	2558.5
		4A12	15.65		841	2944	2943.5
		4A14	16.00		1003	3511	3510.5
		4B14	16.00		1247	4365	4364.5
		4B16	16.26		1479	5177	5176.5
		4C16	16.26		1849	6472	6471.5
		4D16	16.17		2065	7228	7227.5
		4D17	16.17		2537	8880	8879.5
		4E17	16.17		3045	10658	10657.5
		4E18	15.63		3481	12184	12183.5
		4F18	15.63		4437	15530	15529.5
		4F19	15.47		5133	17966	17965.5
5	18	4A10	16.80	All	6177	21620	21619.5
		4A12	17.12		7569	26492	26491.5
		4A14	17.50				
		4B14	17.50				
		4B16	17.78				
		4C16	17.78				
		4D16	17.78				
		4D17	17.68				
		4E17	17.68				
		4E18	17.10				
		4F18	17.10				
		4F19	16.92				

Storing and Transporting

Storage Location

- Store the unit in a clean, dry area.
- **Do not** store outdoors or in an area with high humidity, dust, sudden temperature changes, or corrosive gases.

Generally, the Cyclo® BBB4 gearbox is to be stored indoors, in an ordinary factory or a warehouse. The unit should be sealed, wrapped in plastic and additionally packed with desiccant. Desiccant should be replaced periodically to keep the inside of the box dry. Use of color changing desiccant will aid in identifying when desiccant should be changed.

Storage Period

- **Do not** store the unit for longer than 3 months without following long-term storage procedures recommended by Sumitomo.
- Consult Sumitomo when storing the unit for more than 3 months. Rust proofing procedures are required.
- Consult Sumitomo when exporting the unit. Rust proofing procedures may be required.

If the Cyclo® BBB4 gearbox will be inactive for a long period of time, long-term storage preparation is required to prevent rust or other degradation to the gearbox.

LONG-TERM STORAGE SPECIFIED WITH ORDER:

If long-term storage is specified at the time of order entry, Shell VSI Circulating Oil #32 or NP-20 [JIS] equivalent rust preventative is already sprayed into the Cyclo® BBB4 reducer and the air vent is replaced with a sealing plug before shipping the reducer from Sumitomo factory. External machined surfaces are coated with a suitable NP-19 [JIS] petroleum base corrosion preventative such as Black Bear Par-Al-Ketone, Houghton Rust Veto 342, Daphne Ever Coat No.1 or equivalent.

Consult Sumitomo for Long Term Storage procedures:

- Storage without factory preparations
- Ongoing maintenance during storage period

Operation After Storage

Before operating the unit after an extended storage period, flush unit of rust preventative and ensure that non-metal parts, i.e., oil seals, o-rings, air breather, have not deteriorated. Non-metal parts may deteriorate easily from exposure to ambient conditions (i.e., extreme temperatures, UV rays). Replace deteriorated parts with new before unit start-up.

After starting the unit, verify that there is no abnormal noise, vibration, and/or temperature rise. Immediately stop the unit and call your local distributor, Original Equipment Manufacturer or Sumitomo directly if you observe any abnormality.

Transporting



- **Do not** stand directly under a unit suspended by a lifting mechanism. Injury or death may occur if the unit is dropped.
- **Before lifting the unit**, determine its weight (refer to catalog, packing list, etc.) and ensure that the moving equipment will support the unit's weight.
- **Never hoist or move a unit that exceeds the moving equipment's rated capacity** or else personal injury and/or equipment damage may occur.
- **Do not** allow the unit to drop or fall while moving. **Always use the eye bolts** attached to the gear housing (and on motor if supplied) when moving the unit. After securing the unit to the machine, remove the moving hooks/straps from the eyebolts.

Installation Precautions



- Do not use the reducer/gearmotor for specifications other than those shown on the nameplate or in the manufacturing specification documents. Personal injury and/or equipment damage may occur.
- Do not place combustible material on or around the unit; fire may occur.
- Do not place any objects around the unit that will prohibit proper ventilation. Inadequate ventilation may lead to high unit temperature and/or fire.
- Do not step on or hang from the unit. Excessive weight may cause component breakage leading to personal injury and/or equipment damage.
- Do not touch the shaft, keyway, or motor fan with bare hands; injury may occur.
- For applications in which lubricant leaks could adversely affect operations (i.e., package handling, food processing), place an oil pan below the unit to protect against contamination that may occur if oil seals become damaged or worn.
- Do not remove the eye-bolt from the motor. Should the eye-bolt need to be removed for any reason, install a replacement bolt in the tapped hole to prevent water from entering the motor.

Installation Location

Ambient Temperature Range ...	14° - 104°F (-10° - 40°C)
Ambient Humidity.....	85% or less
Ambient Conditions.....	14°F minimum
Altitude	3,280 feet (1,000 m) or less
Atmosphere	The location should not contain corrosive gas, explosive gas, or steam. The location should be free of dust and well ventilated.
Location	Indoor – free of dust and water

Consult Sumitomo when the unit will operate in conditions other than those specified above. Special unit modifications may be required.

Units manufactured according to customer specified application requirements (i.e. outdoor modifications, high-temperature modifications) are designed to operate within the specified environment.

Install the unit so inspection and/or maintenance procedures may be easily performed. Install all units that are not shaft mounted on a sufficiently rigid base.

Torque arm clearance with machine structure is required to allow for machine shaft run out. Refer to the Torque Arm Installation section in this manual for additional information.

Installation Angle

Mount the unit in the specified position for which it was ordered. Confirm the mounting position from the gearbox nameplate.

Consult your local distributor, Original Equipment Manufacturer or Sumitomo directly if the mounting angle is to be **other than horizontal or vertical**.

Severe Loading Conditions

For applications with severe vibration and/or frequent starts and stops, Sumitomo recommends the use of high-strength mounting bolts of Grade 8.8 (or greater).

Installation onto the Driven Machine



- Before coupling the reducer/gearmotor to the machine, verify the appropriate/desired rotation of the machine. Differences in the rotational direction may cause personal injury and/or equipment damage.
- Before operating the unit, ensure that all safety guards around the rotating components are in-place and secure. Failure to do so may result in personal injury.
- When joining the reducer or gearmotor to the load, ensure that the center alignment, belt tension, and/or parallelism of the coupling device are within the coupling manufacturer's established recommendations. For applications with a belt, ensure that the belt is properly tensioned to the manufacturer's specification, and the bolts securing the pulley and couplings are sufficiently tightened. Failure to follow these precautions may result in personal injury and/or equipment damage.

Installation onto Driven Shaft

Taper-Grip® Bushing

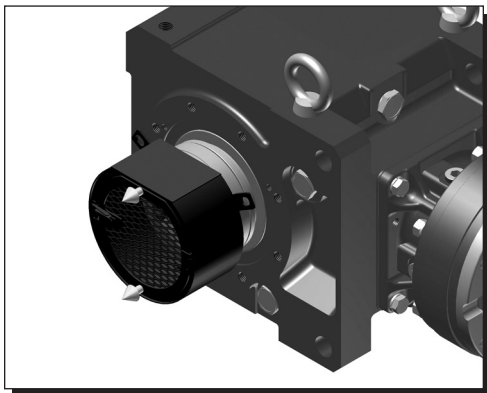
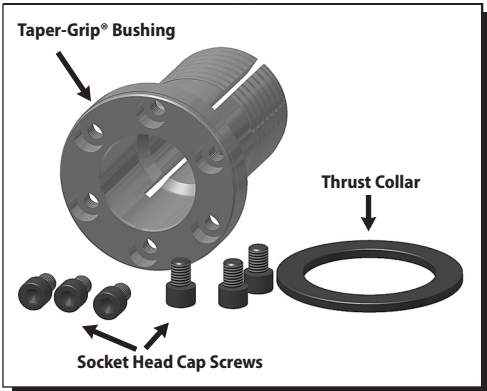
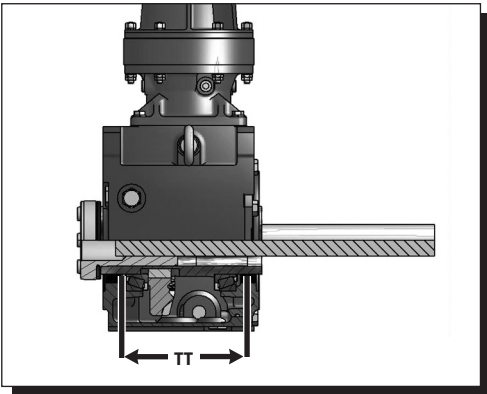
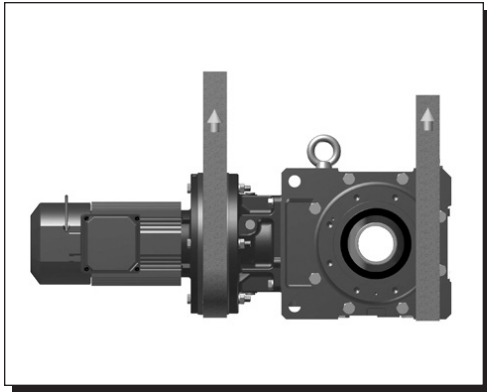

Taper-Grip® Bushing Introduction

The keyless Taper-Grip® bushing system provides a simple and reliable shaft attachment for Sumitomo speed reducers and gearmotors. This system allows bi-directional shaft rotation operation with a powerful, slip-free grip. To assure peak performance of your equipment, please read, understand and follow these installation instructions.



Prior to installation of the Cyclo® BBB4 onto the driven shaft, ensure that the shaft length meets or exceeds the minimum shaft engagement value "TT" detailed in Table 1.



Do not operate unit until the torque arm has been attached to the unit and fixed to a rigid structure. The torque arm prevents counter-rotation during unit operation. Refer to torque arm installation section in this manual for instructions.



CAUTION: The Cyclo® BBB4 must be externally supported prior to insertion of driven shaft into bushing. External support **MUST** be maintained until all bushing socket head cap screws have been tightened to the appropriate operational torque.

Components of Taper-Grip® Bushing

As shown in the figure on the left, the Taper-Grip® bushing includes the **bushing**, **thrust collar**, and **socket head cap screws**.

Table 1. Driven Shaft Tolerance ^[1] and Minimum Shaft Engagement (TT)

Shaft Diameter (in)	Tolerance (in)
1-3/16 – 1-15/16	+0 / -0.0015
2 – 3-1/8	+0 / -0.0018
3-3/16 – 4-11/16	+0 / -0.0021
4-3/4 – 6-1/2	+0 / -0.0025

Shaft Diameter (mm)	Tolerance (µm)
(30 - 50)	(+0 / -39)
(50 - 80)	(+0 / -46)
(80 - 120)	(+0 / -54)
(120 - 180)	(+0 / -63)

Cyclo® BBB4 Size	TT (mm)	TT (in)
4A	(208)	8.19
4B	(242)	9.53
4C	(279)	10.98
4D	(326)	12.83
4E	(359)	14.13
4F	(412)	16.22

Note: [1] Based on ISO/JIS/DIN h8

Taper-Grip® Bushing Installation onto Driven Shaft

1

Remove **bushing cover** if unit was supplied with one.

Installation onto Driven Shaft, continued

Taper-Grip® Bushing

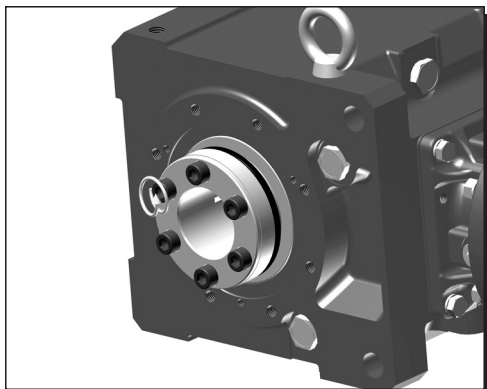

2

Loosen **socket head cap screws**.

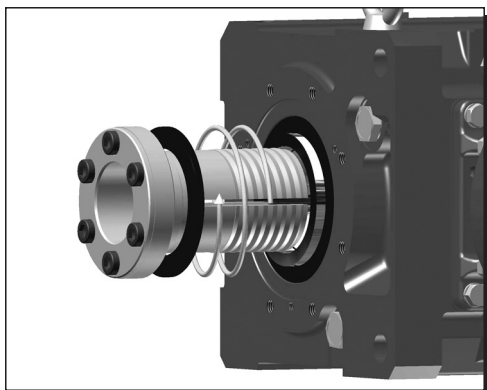

3

Remove (unscrew) Taper-Grip® bushing from the unit.

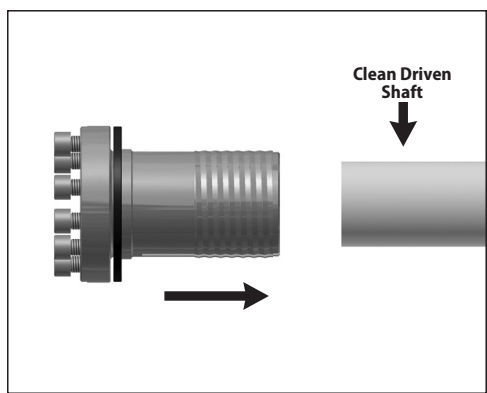

4

Clean all **grease, oil** and/or **anti-seize paste** from the driven shaft. Failure to do so could result in damage to shaft.

Slide Taper-Grip® bushing onto driven shaft.

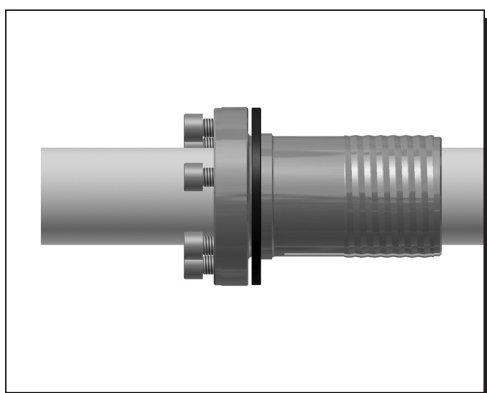

5

Inspect and test Taper-Grip® bushing on shaft.

- Check shaft for **burrs, corrosion, or warp**. Repair or replace shaft as necessary.
- Slide bushing back and forth along shaft, checking for surface irregularities and fit.
- Verify bushing is sized correctly for the shaft diameter.

Installation onto Driven Shaft, continued

Taper-Grip® Bushing

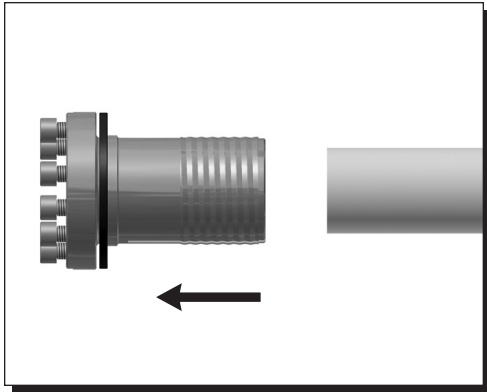

6

Remove Taper-Grip® bushing from driven shaft.

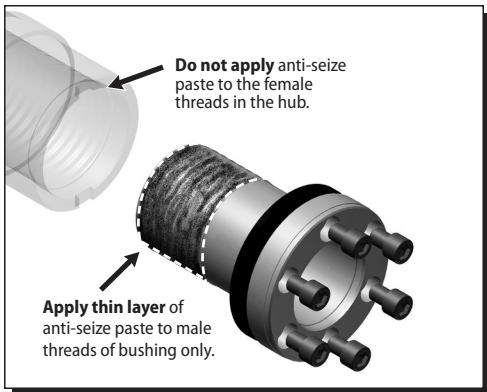

7

Apply a thin layer of anti-seize paste to the male threads of the Taper-Grip® bushing only.



Ensure that the anti-seize paste does not enter the Taper-Grip® bushing bore.

Do not apply anti-seize paste to the female threads in the hub.

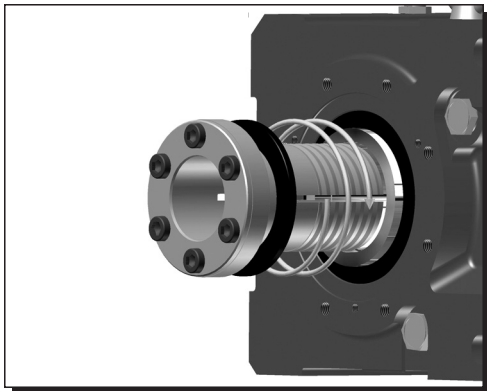

8

Screw Taper-Grip® bushing into Cyclo® BBB4 leaving **approximately 1 mm gap between the bushing flange and thrust collar.**



Do not apply grease, oil, or anti-seize paste to the driven shaft or the bushing bore before placing the unit onto driven shaft. Use of these friction-minimizing products will adversely affect the ability of the unit to transmit torque.



CAUTION: The Cyclo® BBB4 must be externally supported prior to insertion of driven shaft into bushing. External support **MUST** be maintained until all bushing socket head cap screws have been tightened to the appropriate operational torque.

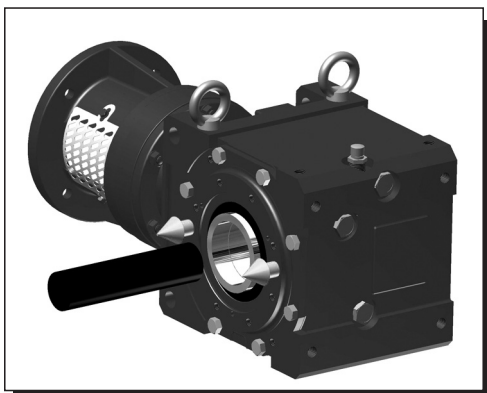

9

Mount or slide the Cyclo® BBB4 onto the driven shaft to the desired location.



Do not rock or pry the unit.

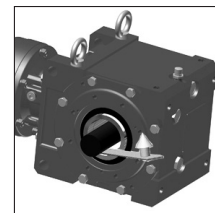
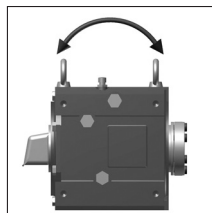

Installation onto Driven Shaft, *continued*

Taper-Grip® Bushing

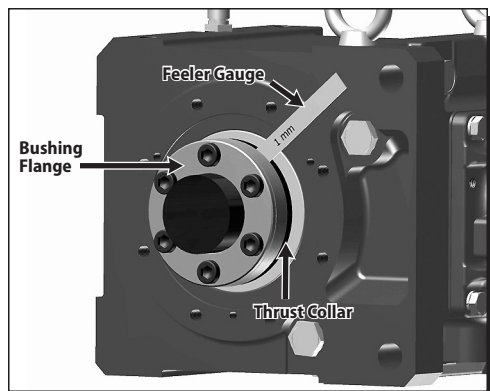
**10**

Screw Bolts into Taper-Grip® bushing.

- Lightly oil threads of each bolt before inserting.
- Finger tighten each bolt to secure in place.
- Be sure to **maintain the 1 mm** (approximate) **gap** between the **thrust collar** and the **bushing flange**.

11

Tighten bushing bolts to the correct torque value.

- Following a star pattern, use a torque wrench to **gradually tighten each socket head cap screw in 20% increments**.
- Refer to **Table 2, Taper-Grip® Bushing Bolt Tightening Torques**, for the correct operational screw torques.

Table 2. Taper-Grip® Bushing Bolt Tightening Torques

Cyclo® BBB4 Size	Screw Qty x Size	Screw Torque	
		lb-ft	(N·m)
4A	6 x M12	56	(75)
4B	6 x M12	104	(140)
4C	6 x M16	185	(250)
4D	6 x M16	223	(300)
4E	8 x M16	223	(300)
4F	10 x M16	223	(300)

12

In order to prevent corrosion, apply grease to the exposed portion of the driven shaft.

- **After installing and tightening** the bushing bolts with a torque wrench, **apply grease or an anti-corrosion product** to the exposed portion of the shaft.

13

After the reducer has been running for 20 to 30 hours, re-torque the screws to the values in Table 2. Screw torques should be subsequently checked at normal service intervals (i.e. every 6 months).

14

For units that include a bushing safety cover, reinstall the guard over the Taper-Grip® bushing.



Do not operate unit until the torque arm has been attached to the unit and fixed to a rigid structure. The torque arm prevents counter-rotation during unit operation. Refer to torque arm Installation section in this manual for instructions.

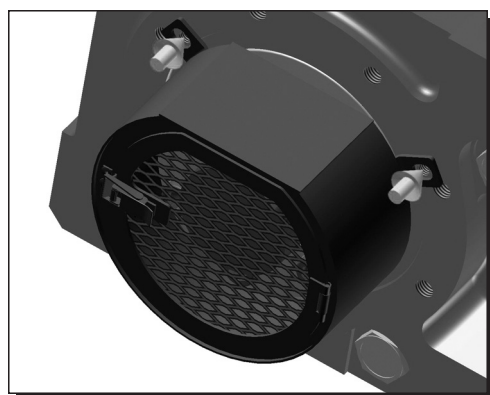
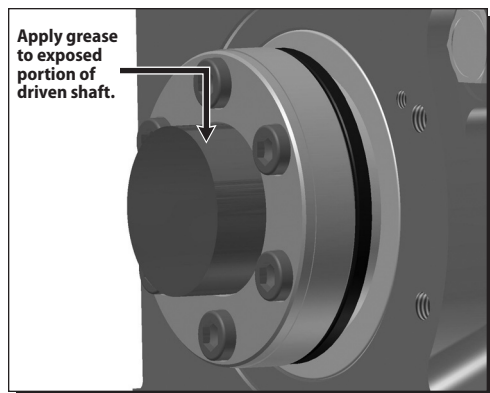
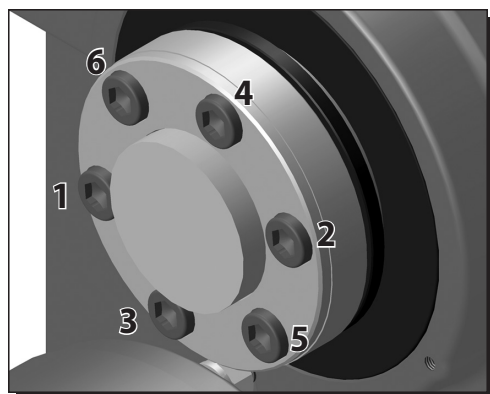

Installation onto Driven Shaft, continued

Keyed Hollow Bore

Keyed Hollow Bore Installation



Do not operate unit until the torque arm has been attached to the unit and fixed to a rigid structure. The torque arm prevents counter-rotation during unit operation. Refer to torque arm Installation section in this manual for instructions.



CAUTION: The Cyclo® BBB4 must be externally supported prior to insertion of driven shaft into hollow bore.

Bore and Shaft Tolerance Specifications

- Unless otherwise specified, the tolerance of the Hollow Shaft Bore conforms to JIS H8.
- If application involves high shock loading and/or large radial loads, a shaft tolerance of JIS js6 or JIS k6 is recommended.

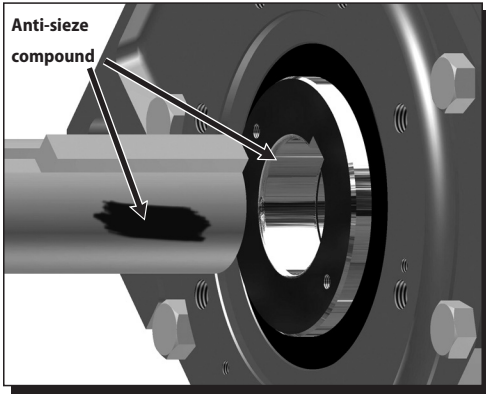

Keyed Hollow Bore Installation onto Driven Shaft

1

Apply anti seize compound to the driven shaft surface and inside the reducer keyed hollow bore.

2

Align the driven shaft with the reducer/gearmotor bore and carefully slide unit onto the driven shaft to the desired location.



If the fit is tight, strike on the keyed hollow bore with a wooden or hard rubber mallet to assist in the assembly.

If using a mallet during installation, strike **only** against the unit's steel keyed hollow bore. Do not strike the reducer housing or oil seal as damage to the bearings, housing and/or seals may occur.

Note: If the fit is tight, use a jig such as the one shown in Table 3 to ease assembly. **Sumitomo does not supply a mounting jig. This information is provided for reference only.**

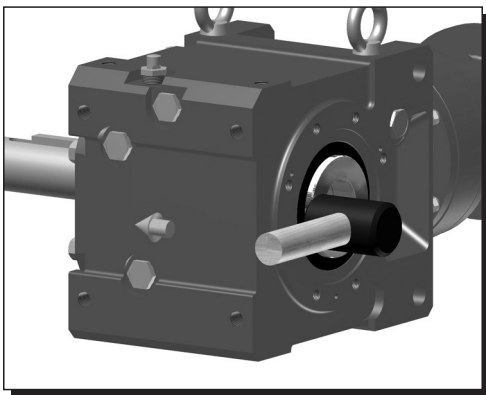

Installation onto Driven Shaft, continued

Keyed Hollow Bore, Shrink Disc Type Hollow Bore

Table 3. Jig Dimensions (mm)

Size	a	b	c	d	e
	CC (ISO/JIS)	A2	Bearing	Nut	Threaded Rod
4A	55	25	51104	M16	M16 x 250
4B	65	25	51105	M20	M20 x 300
4C	75	25	51105	M20	M20 x 300
4D	85	35	51107	M24	M24 x 400
4E	100	35	51107	M24	M24 x 400
4F	120	46	51109	M30	M30 x 450

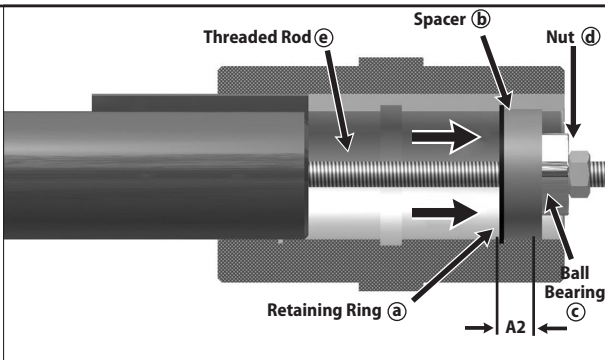
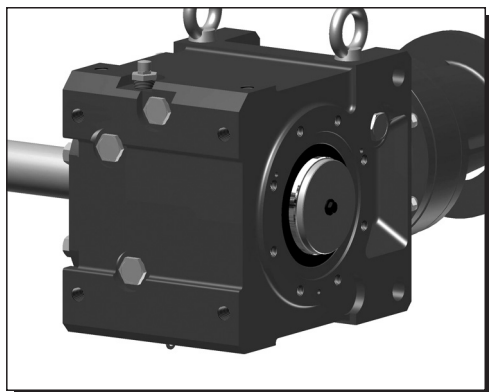
3

Once driven shaft has been completely inserted into the unit's keyed hollow bore, secure the shaft in place using a keeper plate as shown to the left, or some other means of securing the unit to the driven shaft.



Do not operate unit until the torque arm has been attached. Refer to the Torque Arm Installation section in this manual for instructions.

Shrink Disc Type Mounting Introduction

The **keyless Shrink Disc** provides a reliable commodity shaft attachment for Sumitomo speed reducers and gearmotors. This system allows bi-directional shaft rotation operation with a powerful, slip-free grip.

To assure peak performance of your equipment, please read, understand and follow these installation instructions.



Do not operate unit until the torque arm has been attached to the unit and fixed to a rigid structure. The torque arm prevents counter-rotation during unit operation. Refer to torque arm Installation section in this manual for instructions.



CAUTION: The Cyclo® BBB4 must be externally supported prior to insertion of driven shaft into hollow bore. External support **MUST** be maintained until all shrink disc socket head cap screws have been tightened to the appropriate operational torque.

Bore and Shaft Tolerance Specifications

- Refer to the certified outline drawing or Cyclo® BBB4 Catalog for recommended machine shaft dimensions.
- Unless otherwise specified, the tolerance of the Shrink Disc Bore conforms to JIS H8.
- If application involves high shock loading and/or large radial loads, a shaft tolerance of JIS js6 or JIS k6 is recommended.

Installation onto Driven Shaft, continued

Shrink Disc Type Hollow Bore

Shrink Disc Type Hollow Bore Installation onto Shaft

 Before placing unit onto driven shaft, **do not apply grease, oil, or anti-seize paste to the entire driven shaft or to the bore of the shrink disc.** Use of these friction-minimizing products will adversely affect the ability of the unit to transmit torque. Never tighten locking screws before shaft installation. Inner ring may become permanently contracted even at low tightening torques.

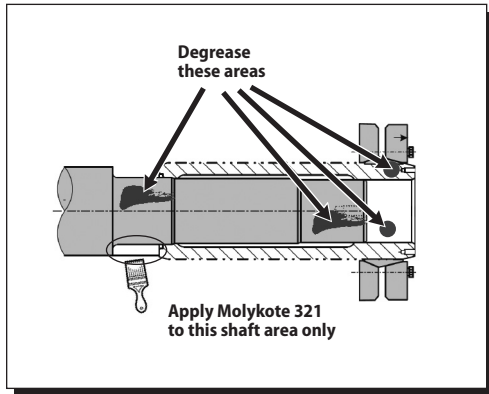

1

Clean and degrease contact surfaces; reducer shaft and bore, and the machine driven shaft.

Apply Molykote 321 or an equivalent dry film lubricant to the driven shaft shoulder opposite from the shrink disc.



Do Not apply any friction minimizing compound to the driven shaft at or near the shrink disc.

2

Align the driven shaft with the bore of reducer/gearmotor bore and carefully slide unit onto the driven shaft to the desired location.

- If the fit is tight, strike on the reducer hollow bore with a mallet to assist in the assembly.



If using a mallet during installation, strike **only** against the unit's steel hollow bore. **Do not** strike the reducer housing or oil seal, as damage to the bearings, housing, and/or seals may occur.

If the fit is tight, use a jig such as the one shown in the Keyed Hollow Bore Installation section to ease assembly. **Sumitomo does not supply a mounting jig. This information is provided for reference only.**

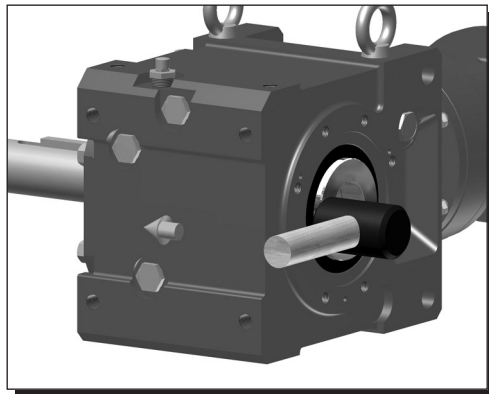
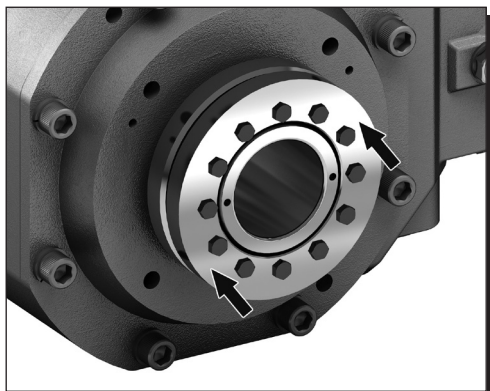

Table 4. Shrink Disc Bolt Tightening Torques

Size	Model (Typical)	Bolt	Bolt Torque	
			lb-ft	(N·m)
4A	TAS-3071-55x68	10 x M6x25 ISO/JIS grade 10.9	9	(12)
4B	TAS-3071-65x80	7 x M8x30 ISO/JIS grade 12.9	26	(34)
4C	TAS-3071-75x100	12 x M8x35 ISO/JIS grade 12.9	26	(34)
4D	TAS-3071-85x110	9 x M10x40 ISO/JIS grade 12.9	51	(68)
4E	TAS-3071-100x140	10 x M12x45 ISO/JIS grade 12.9	87	(118)
4F	TAS-3071-120x165	8 x M16x55 ISO/JIS grade 12.9	214	(290)

Installation onto Driven Shaft, continued

Shrink Disc Type Hollow Bore



3

- Set the (untightened) shrink disc on the reducer shaft.

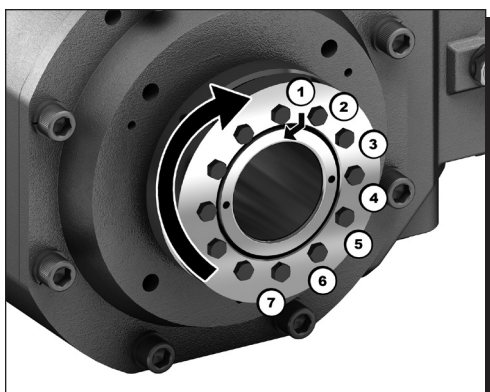

4

Tighten Bolts to the correct torque value.

- For 3-piece design shrink disc, make sure that both plates are parallel when tightening bolts.
- After confirming that the shrink disc is set correctly, tighten the bolts uniformly, in a clockwise pattern while keeping both plates parallel (**not** diagonally or 'star' pattern).
- It is recommended to tighten respective bolts by 30 degrees each time – until the specified torque is reached.

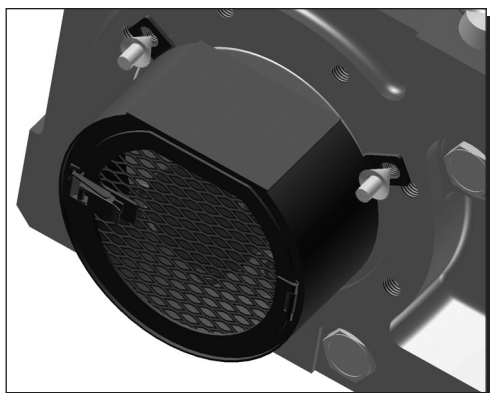

5

For units with a safety cover, install the guard over the **shrink disc**.



Do not operate unit until the torque arm has been attached. Refer to the Torque Arm Installation section in this manual for instructions.

Torque Arm Installation

Torque Arm Introduction, Turnbuckle Type Torque Arm

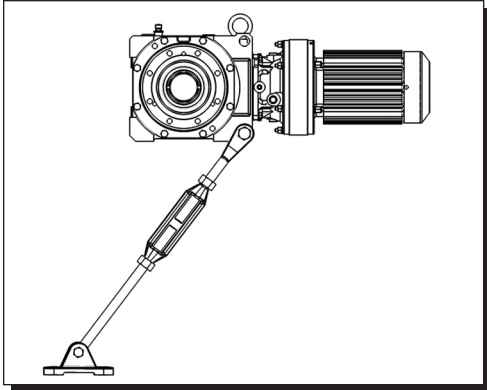

Torque Arm Introduction

A **torque arm** is a device used to prevent counter-rotation of the shaft mounted reducer/gearmotor during operation.



The torque arm **must** be mounted in **tension** when torque arm mounting point is greater than 6 inches (150mm) from machine mounting point or, tie-rod or turn buckle type torque arm is used.

Turnbuckle Type Torque Arm Parts

Figure 1. Turnbuckle Rod Type Torque Arm Parts

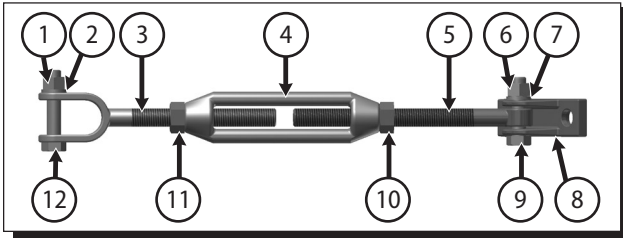
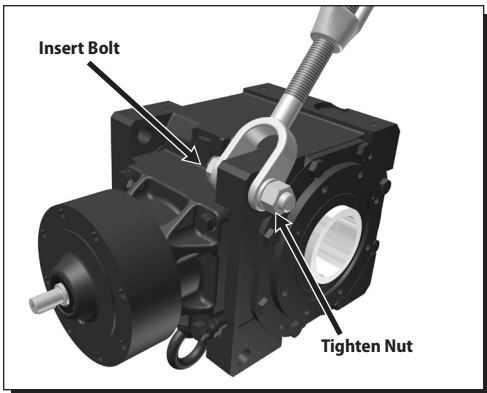

Table 5. Turnbuckle Type Torque Arm Parts

Item Number	Description	Item Number	Description
1	Hex Nut	7	Locke Washer
2	Lock Washer	8	Fulcrum Mounting Bracket
3	Threaded Extension Rod	9	Hex Bolt
4	Turnbuckle	10	Locking Nut (if supplied)
5	Threaded Arm	11	Locking Nut (if supplied)
6	Hex Bolt	12	Hex Bolt



1

Attach the torque arm threaded extension rod to the bevel housing, as shown in Figure 1, at the housing corner eyelet, using the appropriate nut, bolt and lockwasher.

- Insert the bolt through the brackets, torque arm sleeve (if supplied) and reducer housing eyelet.
- Place the lockwasher on the bolt and secure with nut.

Table 6. Bolt Tightening Torques

Unit Size	Bolt Size ^[1]	ft·lb _f	(N·m)
A	M16 x 75	152 – 167	(206 – 227)
B	M20 x 100	290 – 319	(392 – 431)
C	M24 x 105	507 – 558	(686 – 755)
D	M24 x 125	507 – 558	(686 – 755)
E	M24 x 125	507 – 558	(686 – 755)
F	Consult Factory		

Note: [1] Bolt Class equal to ISO/JIS Class 8.8

Torque Arm Installation, continued

Turnbuckle Type Torque Arm

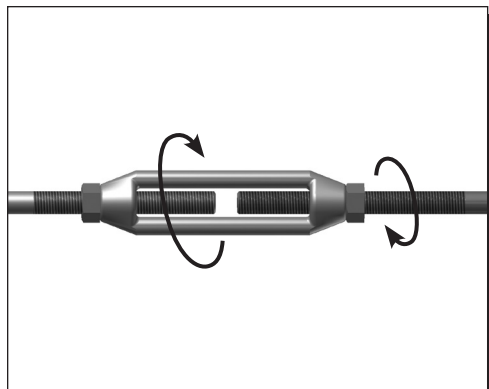

2

Install the turnbuckle onto the threaded extension rod (gearbox side) and then threaded arm (foundation side) to the turnbuckle

If the assembly was supplied with hex nuts to secure the turnbuckle, install the nuts loosely, ensuring the left hand nut is used on the threaded arm, prior to installing the turnbuckle and threaded arm

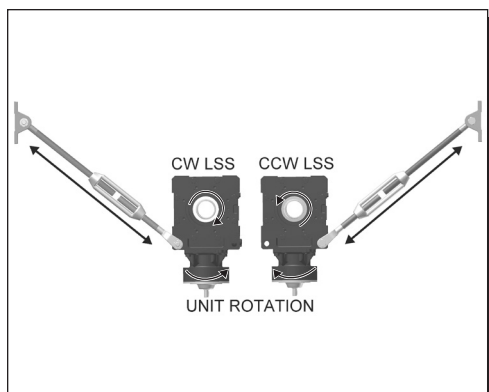

3

Position the torque arm so it will be in tension during unit operation and mount the fulcrum mounting bracket to suitable structure or foundation. Consider installing two torque arms for reversing applications to allow torque arm to be in tension for each direction of rotation.

Mounting hardware for fulcrum mounting bracket are NOT supplied by Sumitomo.

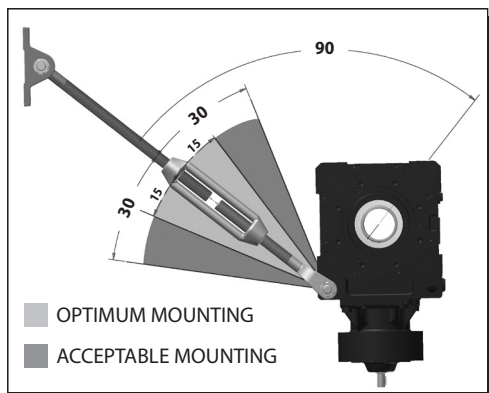

4

Position the torque arm as close as possible to 90° relative to the unit output bore / driven equipment shaft.

Sumitomo does not recommend combining torque arm assemblies to achieve a greater overall length.

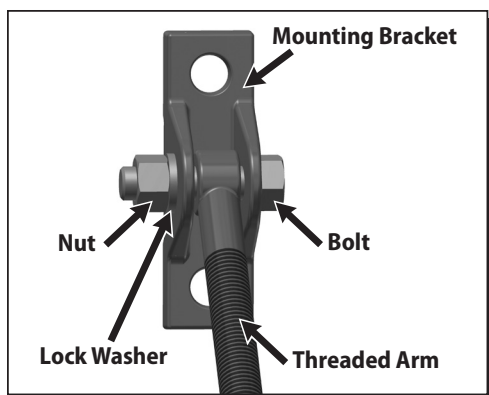

5

Assemble the threaded arm to the fulcrum mounting bracket, as shown.

Some adjustment of the turnbuckle may be required to lengthen or shorten the overall length.

Secure it with the appropriate nut, bolt and lockwasher.

- Insert the bolt through the brackets and threaded arm eyelet.
- Place the lockwasher on the bolt and secure with nut.

Table 7. Bolt Tightening Torques

Unit Size	Bolt Size ^[1]	ft·lb _f	(N·m)
A	M16 x 65	152 – 167	(206 – 227)
B	M16 x 80	152 – 167	(206 – 227)
C	M16 x 80	152 – 167	(206 – 227)
D	M16 x 80	152 – 167	(206 – 227)
E	M16 x 80	152 – 167	(206 – 227)
F	Consult Factory		

Note: [1] Bolt Class equal to ISO/JIS Class 8.8

Torque Arm Installation, continued

Turnbuckle Type Torque Arm, Tie Rod Type Torque Arm

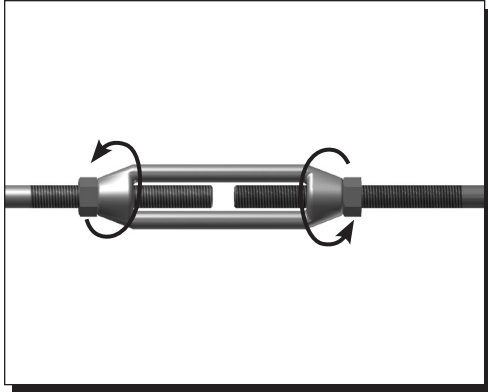

6

If turnbuckle hex nuts were supplied, secure the turnbuckle position by adjusting the previously installed turnbuckle nuts.

Table 8. Nut Tightening Torques

Unit Size	Nut Size ⁽¹⁾	ft·lb _f	(N·m)
A	M20	290 – 319	(392 – 431)
B	M24	507 – 558	(686 – 755)
C	M24	507 – 558	(686 – 755)
D	M24	507 – 558	(686 – 755)
E	M24	507 – 558	(686 – 755)
F	Consult Factory		

Tie Rod Type Torque Arm Parts

Figure 1. Tie Rod Type Torque Arm Parts

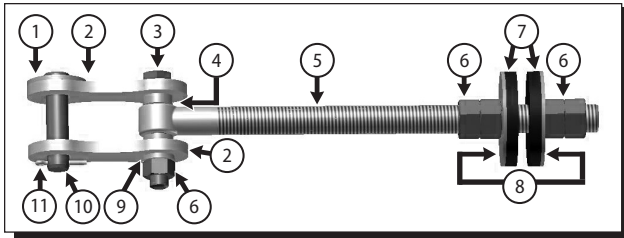
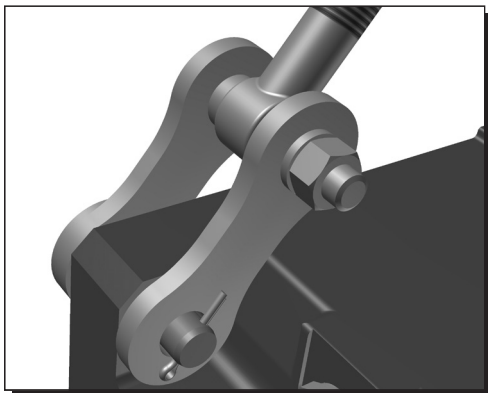

Table 9. Tie Rod Type Torque Arm Parts

Item Number	Description	Item Number	Description
1	Flat Washer	7	Rubber Bushings
2	(2) Mounting Brckts or (1) Clevis	8	Washers
3	Hex Bolt	9	Lock Washer
4	Spacer	10	Clevis Pin
5	Threaded Arm	11	Cotter Pin
6	Hex Nut		



1

Assemble the torque arm mounting brackets or wishbone clevis to the threaded arm, as shown in Figure 1 and attach the torque arm assembly to the bevel housing, at the housing corner eyelet, using the pin and cotter pin.

Tighten mounting bolts according to the values listed in this table:

- Insert the clevis pin through the brackets and housing eyelet.
- Insert the cotter pin into clevis pin and secure assembly.

Table 10. Bolt Tightening Torques

BBB4 Size	Bracket Bolt Size ⁽¹⁾	Torque	
		lb-ft	(N·m)
4A	2 x M16	152 – 167	(206 – 227)
4B	2 x M20	290 – 319	(392 – 431)
4C	2 x M24	507 – 558	(686 – 755)
4D	2 x M24	507 – 558	(686 – 755)
4E	2 x M24	507 – 558	(686 – 755)
4F	Consult Factory		

Note: [1] Bolt Class equal to ISO/JIS Class 8.8

Torque Arm Installation, continued

Tie Rod Type Torque Arm

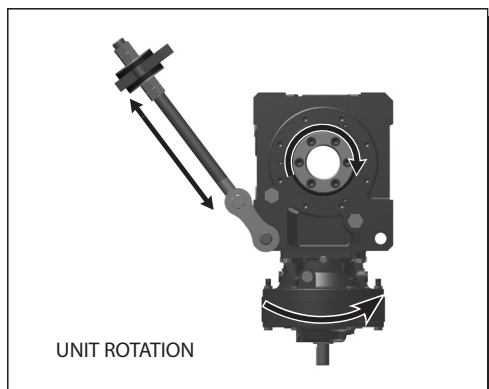

2

Position the torque arm so it will be in tension during unit operation.

Consider installing two torque arms for reversing applications to allow torque arm to be in tension for each direction of rotation.

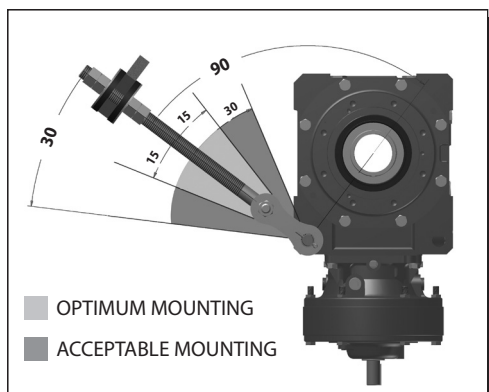

3

Position the torque arm as close as possible to 90° relative to the unit output bore / driven equipment shaft.

Sumitomo does not recommend combining torque arm assemblies to achieve a greater overall length.

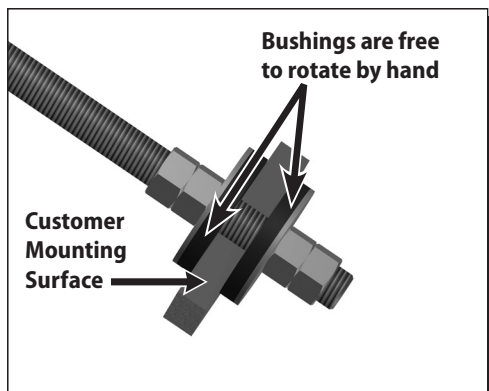

4

After inserting the torque rod into the mounting surface, carefully tighten nuts on either side of torque rod.



Do **not** over tighten nuts. Tighten to point where rubber bushings can still be hand rotated when the unit is turned off.



Before starting unit, verify the following:

- The torque arm will be in tension when the unit is in operation.
- The torque arm is aligned with the reducer housing.
- The torque arm is perpendicular to the axis of the output / driven shaft.
- The threaded arm is not touching the reducer housing.

Torque Arm Installation, continued

Flange Mount (Banjo) Type Torque Arm

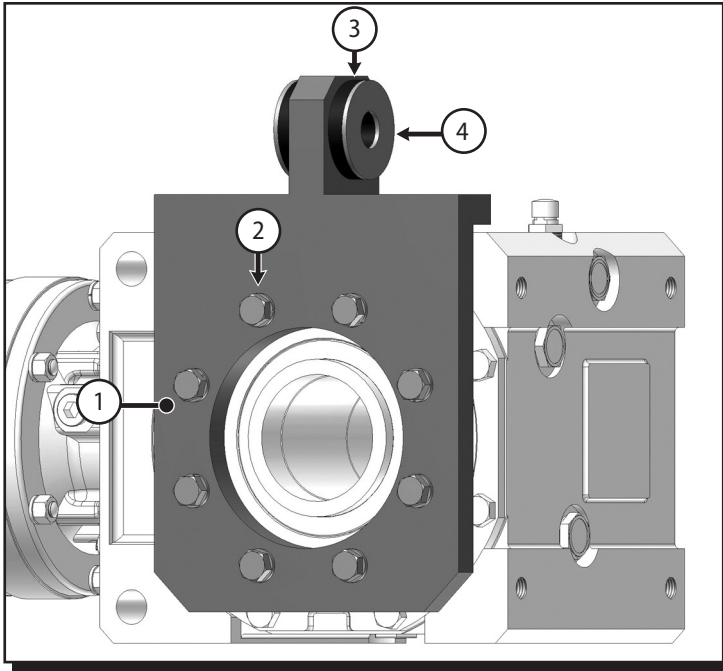

Sumitomo Supplied Components of Flange Mount (Banjo) Type Torque Arm

Table 11. Flange Mount (Banjo) Type Torque Arm Components

Item Number	Description
1	Torque Arm Bracket
2	Bracket Hardware
3	Rubber Bushing (qty 3)
4	Washer (qty 2)

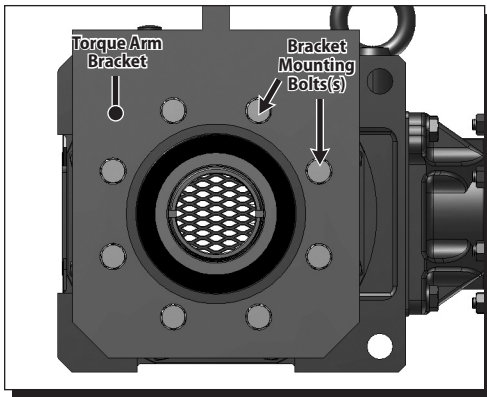

Flange Mount (Banjo) Type Torque Arm Installation Procedure

1

Attach the Flange Mount (Banjo) Torque Arm Bracket to the Cyclo® BBB4 using mounting hardware.

Table 12. Flange Mount (Banjo) Torque Arm Bolt Tightening

Torques Unit Size	Bracket Bolt Size ⁽¹⁾	Torque	
		lb·ft	(N·m)
4A	8 x M10	34 – 38	(46 – 51)
4B	8 x M12	59 – 65	(80 – 88)
4C	8 x M16	152 – 167	(206 – 227)
4D,4E	8 x M20	290 – 319	(392 – 431)
4F	8 x M24	507 – 558	(686 – 755)

Note: [1] Bolt class equal to ISO/JIS Class 8.8

2

Place washer and rubber bushing on bolt.

Insert torque arm bolt (supplied by customer) through mounting tab on Banjo torque arm.



Make sure bolt is parallel to Flange Mount (Banjo) Type Torque Arm surface when fully installed.

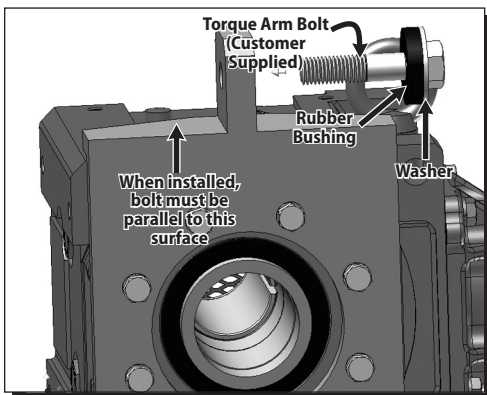

Torque Arm Installation, continued

Flange Mount (Banjo) Type Torque Arm

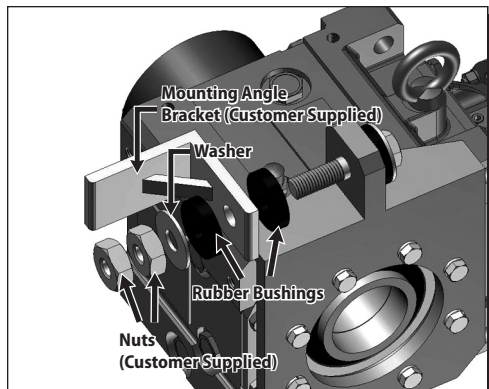

3

Follow these steps to attach the customer supplied mounting bracket.

- Place rubber bushing and mounting angle bracket on bolt.
- Verify that the mounting angle bracket hole is the correct diameter (see Table 13 in Step 1).
- Place remaining bushing, washer and two nuts on the bolt.



Do not over-tighten nuts. Tighten to point where rubber bushings can still be hand rotated.

Table 13. Flange Mount (Banjo) Torque Arm Bolt Dimensions

Unit Size	Bracket Tab Bore	Typical Bolt Size ⁽¹⁾
4A	Ø18mm	M16
4B	Ø18mm	M16
4C	Ø22mm	M20
4D	Ø26mm	M24
4E	Ø33mm	M30
4F	Ø39mm	M36

Note: [1] Bolt class should be greater or equal to ISO/JIS Class 8.8. Application with multiple start/stops and/or shock loading should use ISO/JIS 10.9 at a minimum.

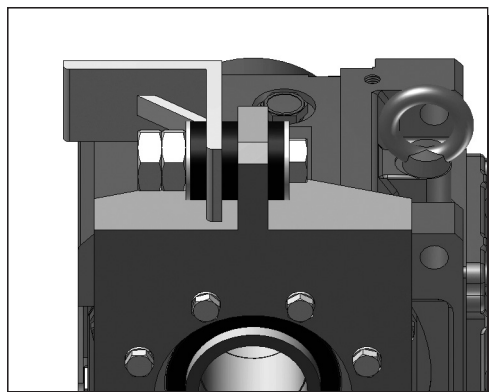

4

Confirm that the rubber bushings can still be rotated by hand. This indicates the bushing has not been over tightened.



Compressed bushings will not allow the bushings to properly absorb the loads of the shaft mounted gearbox. This can lead to premature failure.

Mounting Angle Bracket must be secured to the machine structure.

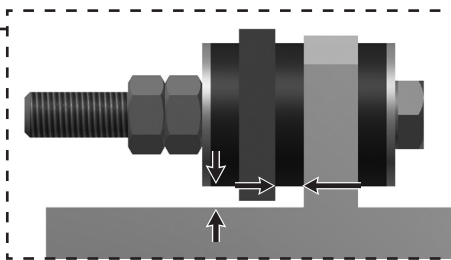
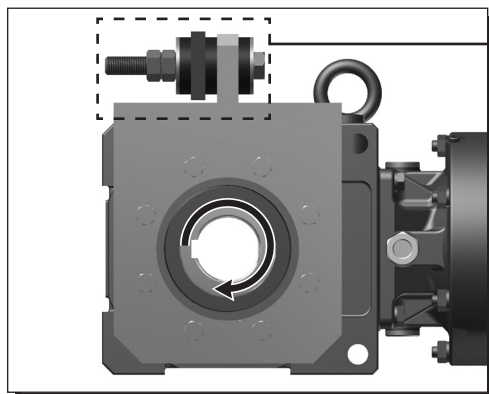

During full rotation of driven shaft, there must be no metal-to-metal contact between mounting angle bracket and torque arm.

5

Confirm the mounting angle bracket does not interfere with the torque arm.

There should be no metal-to-metal contact between the two during a complete revolution of the driven equipment.



Metal-to-Metal contact between these two components may lead to catastrophic failure of the reducer/gearmotor.

Torque Arm Installation, continued

T-Type Torque Arm

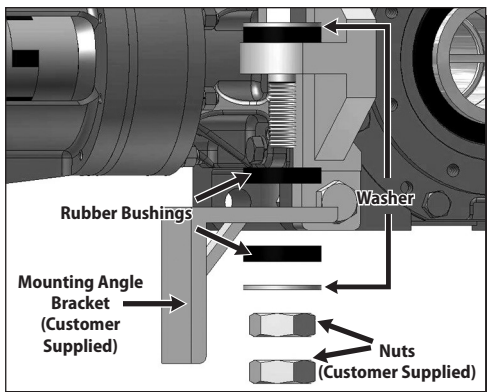
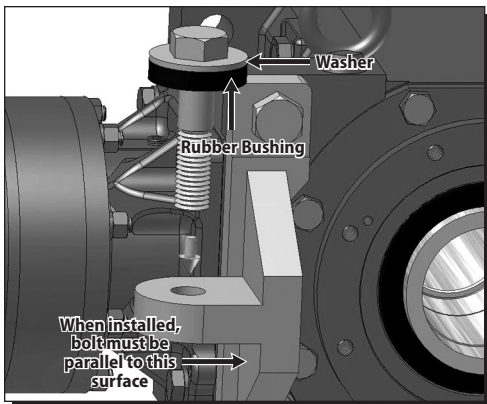
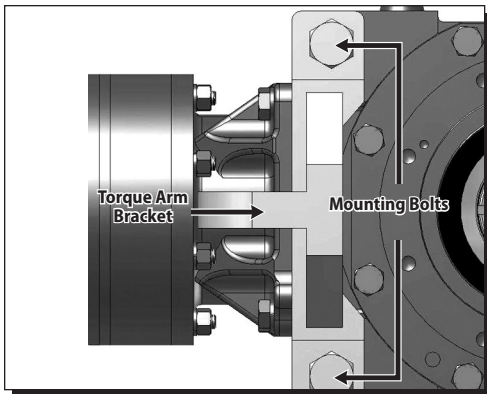
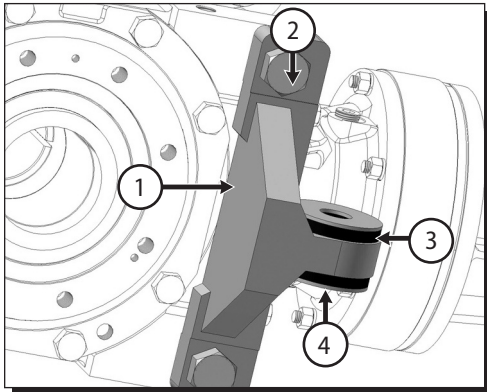

T-Type Torque Arm

Sumitomo Supplied Components for T-Type Torque Arm

Table 14. T-Type Torque Arm Components

Item Number	Description
1	Torque Arm Bracket
2	Bracket Hardware
3	Rubber Bushing (qty 3)
4	Washer (qty 2)

T-Type Torque Arm Installation Procedure

1

Attach the T-Type Torque Arm Bracket to the Cyclo® BBB4 using the supplied mounting hardware.

Tighten mounting bolts according to the values listed in Table 15:

Table 15. T-Bracket Bolt Torques

BBB4 Size	Bracket Bolt Size ^[1]	Torque	
		lb-ft	(N·m)
4A	2 x M16	152 – 167	(206 – 227)
4B	2 x M20	290 – 319	(392 – 431)
4C	2 x M24	507 – 558	(686 – 755)
4D	2 x M30	1014 – 1115	(1373 – 1510)
4E	2 x M30	1014 – 1115	(1373 – 1510)
4F	2 x M36	1844 – 2213	(2500 – 3000)

Note: [1] Bolt class equal to ISO/JIS Class 8.8

2

Place washer and rubber bushing on bolt.

Insert torque arm bolt (supplied by customer) through torque arm mounting tab. T-Type bolt sizes listed in Table 16.



Make sure bolt is parallel to T-Type Torque Arm side when fully installed.

3

Follow these steps to attach the mounting angle bracket:

- Place rubber bushing and mounting angle bracket on bolt.
- Verify that the mounting angle bracket hole is the correct diameter for customer supplied bolt.
- Place remaining bushing, washer and two nuts on the bolt.



Do not over-tighten nuts. Tighten to point where rubber bushings can still be hand rotated.

Torque Arm Installation, *continued*

T-Type Torque Arm

Table 16. T-Type Bolt Dimensions

Unit Size	Bracket Tab Bore	Typical Bolt Size ^[1]
4A	Ø18mm	M16
4B	Ø22mm	M20
4C	Ø26mm	M24
4D	Ø33mm	M30
4E	Ø33mm	M30
4F	Ø39mm	M36

Note: [1] Bolt class should be greater or equal to ISO/JIS Class 8.8. Application with multiple start/stops and/or shock loading should use ISO/JIS 10.9 at a minimum.

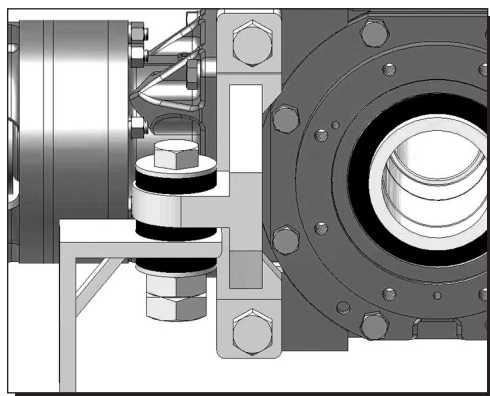

4

Confirm that the **rubber bushings** can still be rotated by hand. This indicates the bushing has not been over tightened.



Compressed bushings will not allow the bushings to properly absorb the loads of the shaft mounted gearbox. This can lead to premature failure.

Mounting angle bracket must be secured to the machine structure.

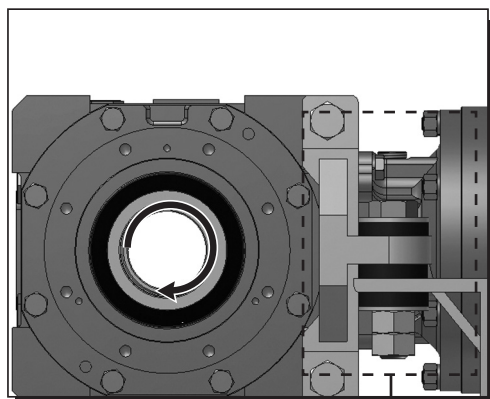

5

Confirm the mounting angle bracket does not interfere with the torque arm.

There should be no metal-to-metal contact between the two during a complete revolution of the driven equipment.



Metal-to-Metal contact between these two components may lead to catastrophic failure of the reducer/ gearmotor.

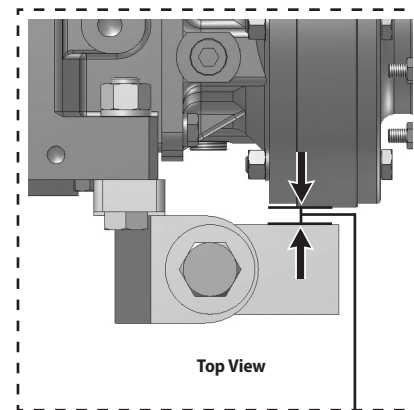
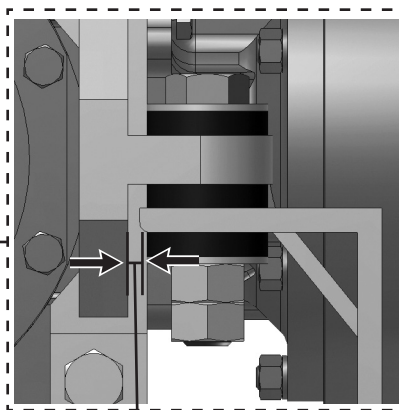

Removal from Driven Shaft

Removal of Cyclo® BBB4 with Taper-Grip® Bushing

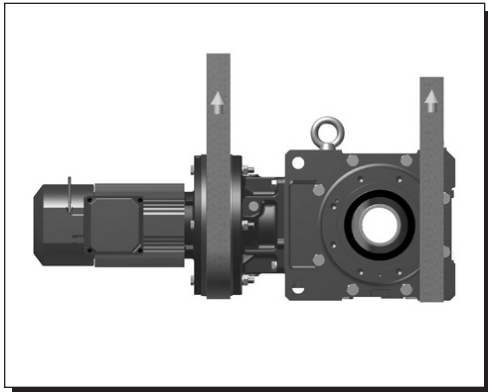

Removal of Cyclo® BBB4 with Taper-Grip® Bushing



Before starting unit removal process, ensure that electrical power to unit has been safely locked out and that electrical connections to the unit have been disconnected.

1

Externally support the Cyclo® BBB4 unit such that all unit weight is removed from the driven shaft.



The weight of the Cyclo® BBB4 must be externally supported throughout the entire removal process.

Do not raise the unit too high. Shaft binding may occur.

2

Remove safety guard from unit. Inspect the Taper-Grip® bushing to ensure that a gap exists between the thrust collar and the bushing flange.

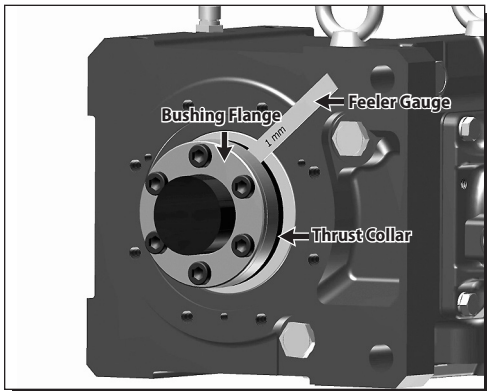

3

Apply a liquid-penetrant onto each of the Taper-Grip® bushing socket-head cap screws. Allow time for the penetrant to settle into the threads of the screws.

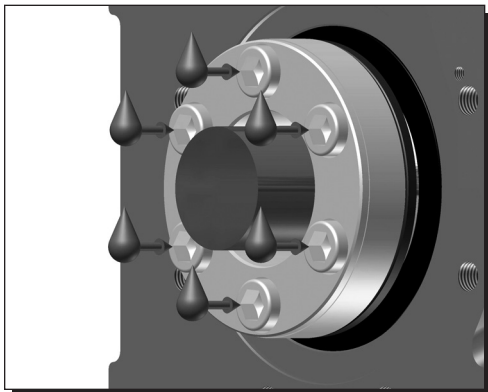

4

After the penetrant has settled, remove the socket head cap screws one at a time.

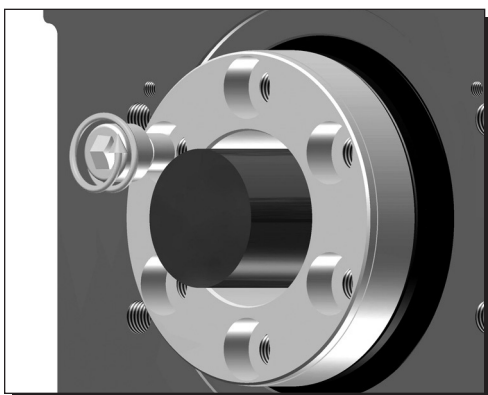

Removal from Driven Shaft, *continued*

Removal of Cyclo® BBB4 with Keyed Hollow Bore

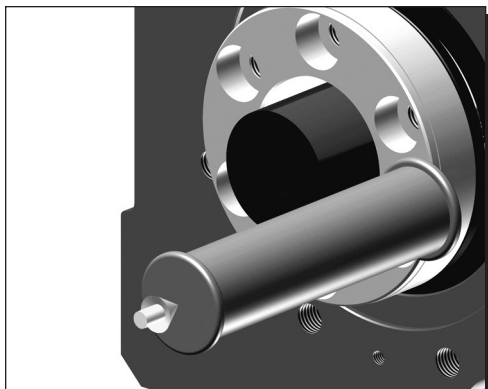

5

Place a soft-metal (i.e. brass) bar against the flange of the Taper-Grip® bushing and carefully strike end of bar with a hammer to release the bushing.

If shaft removal is difficult, a jig such as the one shown in Table 17 may be used to ease the removal process. **Sumitomo does not supply the removal jig.**

This information is supplied for reference only.

Table 17. Removal Jig Dimensions

Size	a	f	g	h
	CC (ISO/JIS)	A3	BOLT	A8
4A	55	19	M24x250	6
4B	65	19	M24x300	6
4C	75	19	M24x300	5
4D	85	24	M30x400	5
4E	100	19	M30x400	5
4F	120	30	M36x450	7

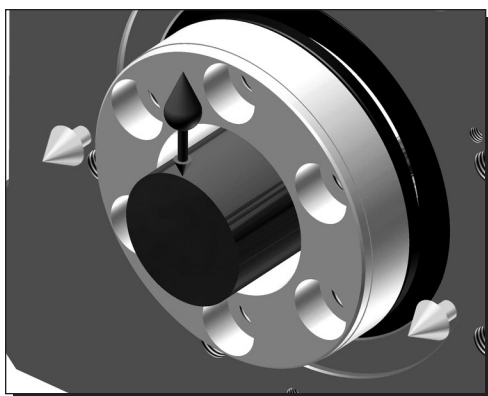

6

Apply a liquid penetrant to the shaft where it contacts the bushing. Allow time for the liquid to settle between the shaft and the bushing wall. Once the penetrant has settled adequately, carefully remove the Cyclo® BBB4 from the driven shaft.

If the Taper-Grip® bushing releases but the unit cannot be removed from the driven shaft, a puller may need to be applied to the bushing flange to pull the unit free from the shaft.

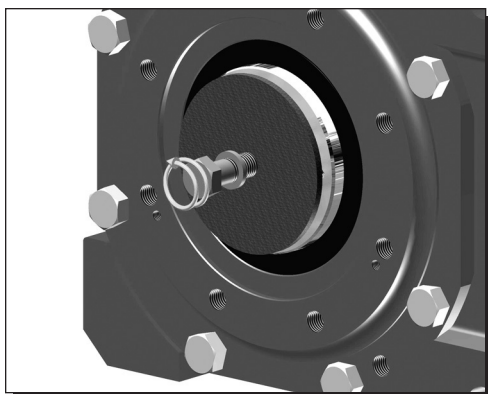

Removal of Cyclo® BBB4 with Keyed Hollow Bore



Before starting unit removal process, ensure that electrical power to unit has been safely locked out and that electrical connections to the unit have been disconnected.

1

Remove safety cover and the shaft-retaining device from the driven shaft.

Removal from Driven Shaft, continued

Removal of Cyclo® BBB4 with Shrink Disc

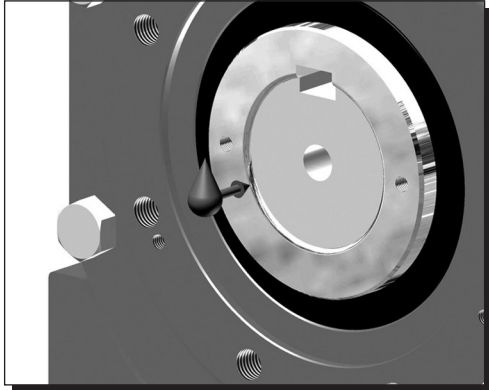

2

Apply a liquid penetrant to the shaft where it contacts the keyed hollow bore. Allow time for the liquid to penetrate between the shaft and the wall of the keyed hollow bore.

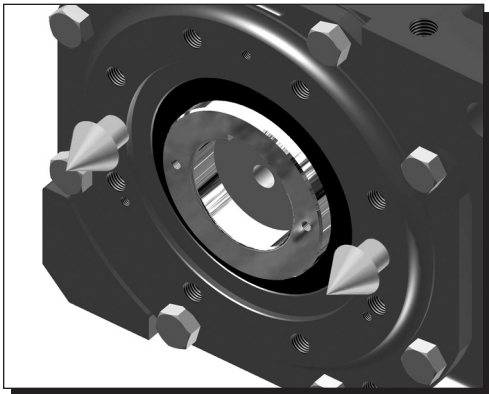

3

Once the penetrant has settled adequately, carefully remove the Cyclo® BBB4 from the driven shaft.

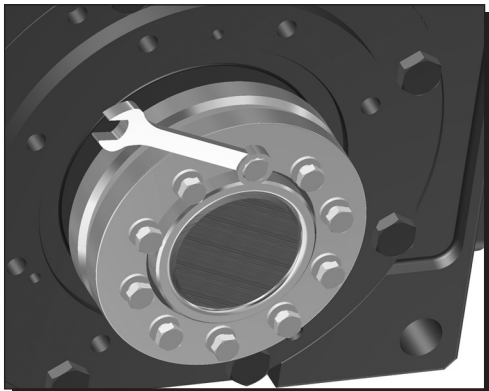

Removal of Cyclo® BBB4 with Shrink Disc



Before starting unit removal process, ensure that electrical power to unit has been safely locked out and that electrical connections to the unit have been disconnected.

1

Remove the safety cover and apply liquid penetrant to the shrink disc bolts and shaft/bore allowing adequate time for proper penetration.

Loosen the locking bolts on the shrink disc.

Complete bolt removal should not be required.

Tapping the shrink disc flanges with a rubber dead blow hammer may be required if any fretting corrosion has occurred.

2

Remove the gearbox from the shaft.

If shaft removal is difficult, a jig such as the one shown in the Removal of Cyclo® BBB4 with Taper-Grip® Bushing section may be used to ease the removal process. **Sumitomo does not supply the removal jig. This information is supplied for reference only.**

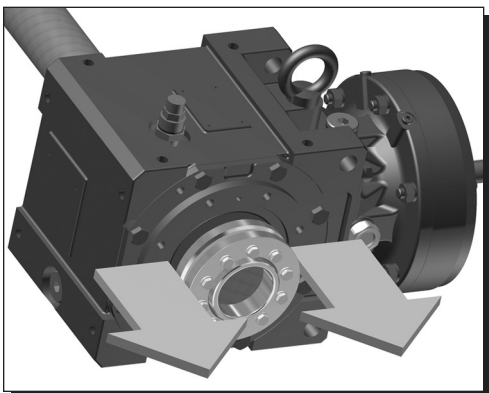

Lubrication

Taconite Seal Lubrication Procedure

Figure 1. Taconite Seal Assembly

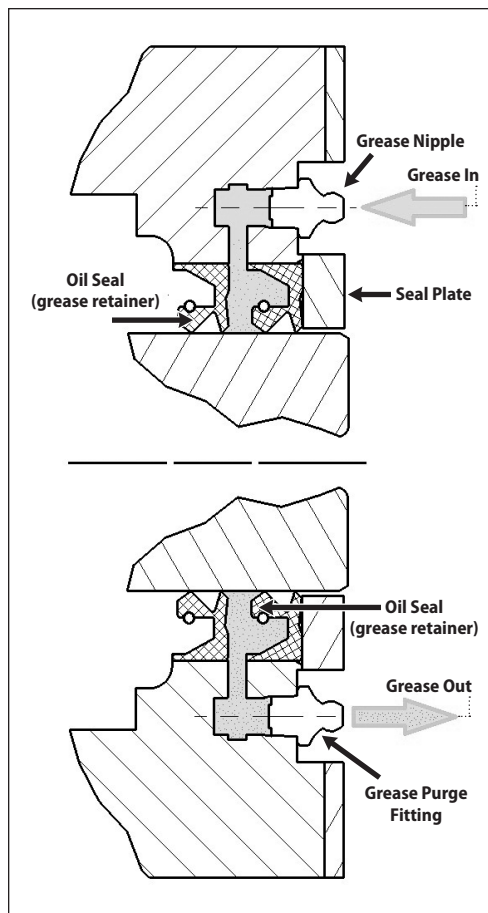

1. Introduction

Taconite seals may be used in high dust operating environments. They use a grease purging system to prevent outside contaminants from entering the speed reducer/gearmotor. Figure 1 to the left details the Taconite Seal assembly as utilized in the 4-Series Bevel Buddybox®.

2. Procedure

Please follow these instructions to maintain lubrication of the Taconite Seal system:

- a. Unless otherwise specified, the Taconite output seals are each packed with NLGI #2 EP mineral grease prior to unit shipment from the factory location.
- b. **Grease does not need to be added to the seals prior to unit start-up.**
- c. Add grease to the seals according to the guidelines indicated in Table 18. Refer to Table 19 for recommended greases.

Table 18. Lubrication Cycle

Output Shaft RPM	Hours of Operation
>200	5,000

Please note that a highly contaminated environment may require a more frequent lubrication cycle.

Table 19. Recommended NLGI#2 Mineral Greases

Grease	BP	Castrol			Chevron/Texaco		Exxon/Mobil		Shell	Total
Mineral	Ener-Grease LS EP2	Spheerol AP3	Olista Longtime 3EP	Tribol 3020/ 1000-2	Duralith Grease EP2	Multifak Grease EP2	Beacon EP2	Mobilux EP2	Alvania EP2	Multis EP2
Food Grade					FM EP2					

Lubrication, continued

Taconite Seal Lubrication Procedure, continued

- d. If the unit will not be operated for a period greater than 6 months, apply a thin layer of grease to the outside surface of the seals to prevent dry-out. Before starting the unit, check the seals' integrity and replace if required. If seal replacement is required, purge and add grease to the newly installed seals prior to unit operation.
- e. Units may be equipped with either a spring loaded grease relief fitting, or a plug in the grease purge port.
 - If your unit has a plug, begin by removing the plug.
 - While rotating the reducer shafts to ensure even grease distribution, **slowly** add grease until new grease begins to come out of the grease purge port. **NOTE: Rotate shafts by hand in this process. Exercise caution in rotating shaft in order to avoid injury.**
 - Wipe away excess grease and reinstall plug if necessary.

Lubrication Introduction



Sumitomo Cyclo® BBB4s units are shipped from the factory **without** lubricating oil, unless the customer specified otherwise when the unit was ordered.

The unit must contain the correct type and amount of lubrication before operating.

For all Y4 motor down mounting configuration models, the Cyclo® portion is filled at the factory with **grease**. For these units, the Cyclo® portion **does not** need to be filled with lubricant before start-up. The Bevel Gear portion of models built for the Y4 mounting configuration requires filling with gear oil before start-up. Refer to the Lubrication Method section for details.

For the Cyclo® BBB4 built for the Y4 mounting configuration, the Cyclo® and the bevel gear portions **must** be filled with lubricant separately and maintained separately. Lubricant **does not** flow from one section to the other.

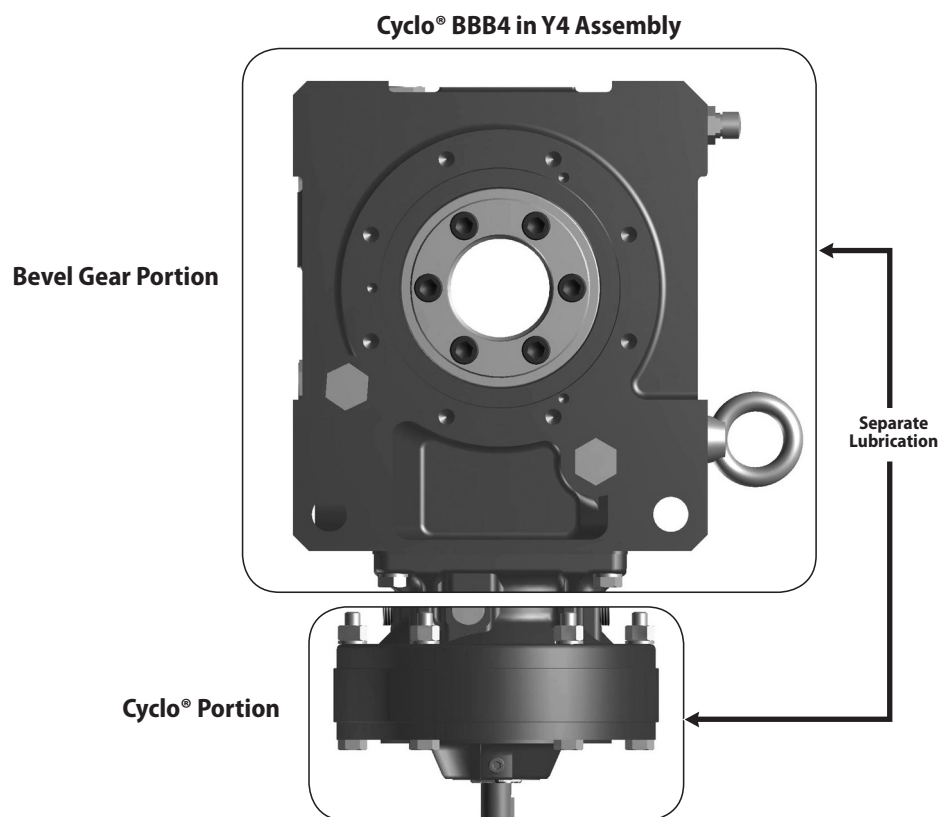

Lubrication Nomenclature

Refer to the **Model** portion of the unit's nameplate to determine the unit size, reduction ratio, and mounting configuration:

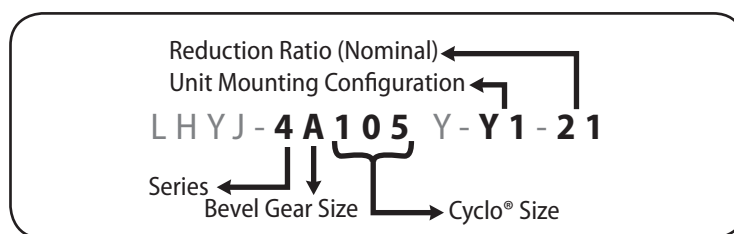

Lubrication, continued

Lubrication Method

Lubrication Method

Using the model number and mounting configuration, refer to Tables 20 and 21 to determine the unit's lubrication method.

Table 20. Lubrication Method for Configurations Y1, Y2, Y3, Y5, Y6



Mounting Configuration	Unit Size		Lubrication Method	
	Bevel Gear Size	Cyclo® Size		
    	4A - 4F	100, 105, 110, 115, 120, 125, 140, 145, 160, 165, 170, 175, 180, 185, 190, 195 10DA, 12DA, 12DB, 14DA, 14DB, 14DC, 16DA, 16DB, 17DA, 17DB, 17DC	Complete Unit (Bevel Gear Portion and Cyclo® Portion)	Common Oil Sump

Table 21. Lubrication Method for Y4 Configuration

Mounting Configuration	Unit Size		Lubrication Method	
	Bevel Gear Size	Cyclo® Size		
	4A-4F	100, 105, 110, 115, 120, 125	Cyclo® Portion	Maintenance Free Grease ^[1]
		10DA, 12DA, 12DB	Bevel Gear Portion	Oil
		140, 145, 160, 165, 170, 175, 180, 185, 190, 195	Cyclo® Portion	Grease ^[2]
		14DA, 14DB, 14DC, 16DA, 16DB, 17DA, 17DB, 17DC, 18DA, 18DB, 19DA, 19DB	Bevel Gear Portion	Oil

Notes: [1] Maintenance Free Grease: the input Cyclo® portion is grease lubricated as standard from the factory and usually does not require replacement or replenishment.

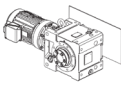
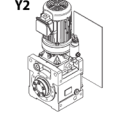
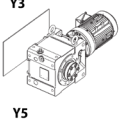
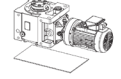
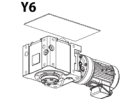
[2] Grease: the input Cyclo® portion is grease lubricated as standard from the factory. Please refer to Tables 27, 28 and 29 for the proper grease replenishment and change interval.

Bevel Gear Portion and Cyclo® Portion Lubricants

Recommended Oils

Table 22, Recommended Oils, lists the oils that may be used to lubricate the Bevel Gear portion of the unit. These oils may also be used in the Cyclo® portion if it is oil lubricated.

ExxonMobil: Spartan EP	Shell Oil: Omala S2 G	Kluber: Kluberol GEM1
ExxonMobil: Mobilgear 600XP	Caltex: Meropa	Idemitsu Oil: Daphane Mechanic
ExxonMobil: Mobil SHC Gear Hi-Shock 150	Castrol: Alpha SP	BP Oil: Energol GR-XP
Food Grade Oil: Klübersynth UH1 6-460	Gulf Oil: EP Lubricant HD	Total: Carter EP

Table 22. Recommended Oils

°F	14	32	50	68	86	104	122
°C	-10	0	10	20	30	40	50
ISO VG	68 (14 °F to 41 °F)		100/150 (32 °F to 95 °F)			220/320/460 (86 °F to 122 °F)	

- Use lubricants with low viscosity for operation during winter or at relatively low temperatures.
- Use lubricant with a viscosity within the range listed in **Table 23, Recommended Oil Viscosity**.

Table 23. Recommended Oil Viscosity

Minimum allowable viscosity	15 cSt (mm^2/s) or more at operating temperature	Viscosity that ensures oil film strength adequate for load transmission.
Maximum allowable viscosity	4300 cSt (mm^2/s) max.	Viscosity that permits start-up of Buddybox®

- Consult local distributor, nearest authorized agent or Sumitomo directly when the unit will be operated in ambient temperatures other than 14° – 104°F (-10° – 40°C). Special unit modifications may be necessary.

Cyclo® Portion Approved Greases

Table 24, Cyclo® Portion Approved Greases, lists the greases that may be used to lubricate the Cyclo® portion if grease is the specified lubrication method (refer to the Lubrication Method section for details).

Table 24. Cyclo® Portion Approved Greases

Ambient Temp. °F (C)	Overall Reduction Ratio	All Unit Sizes
14° – 122°F (-10° – 50°C)	11:1 through 18:1	Shell Gadus S2 V220 NLGI 00
	19:1 and higher	ExxonMobil Unirex N2 grease

Cyclo® portions have unique operating characteristics that require specific lubricant properties. Please consult Sumitomo if alternate lubricants are required.

Lubrication, continued

Oil Quantities

Be sure to check the oil level with the oil gauge. The following listed oil quantities are approximate.

Oil Quantities

Table 25. Single Reduction Approximate Oil Quantity

Units: US liquid gallon (*liter*) **Note: Output = Bevel Gear Portion Input = Cyclo® Portion**

Bevel Gear Unit Size	Mounting Configuration							
	Y1 	Y3 	Y2 	Y4 		Y5 	Y6 	
	Output		Input					
4A10	0.43 (1.62)		0.84 (3.17)		0.30 (1.13)	Grease	0.36 (1.36)	0.49 (1.84)
4A11	0.44 (1.66)		0.86 (3.26)				0.37 (1.40)	0.50 (1.88)
4A12	0.45 (1.71)		0.88 (3.35)				0.38 (1.45)	0.51 (1.93)
4A14	0.50 (1.91)		1.00 (3.77)				0.44 (1.65)	0.56 (2.13)
4B12	0.87 (3.29)		1.72 (6.50)		0.45 (1.72)	Grease	0.88 (3.34)	0.85 (3.23)
4B14	0.92 (3.49)		1.84 (6.97)				0.94 (3.54)	0.91 (3.43)
4B16	1.04 (3.92)		2.01 (7.61)				1.05 (3.97)	1.02 (3.86)
4C14	1.46 (5.52)		2.93 (11.1)				1.40 (5.30)	1.55 (5.88)
4C16	1.57 (5.96)		3.12 (11.8)		0.72 (2.72)	Grease	1.52 (5.74)	1.67 (6.32)
4C17	1.67 (6.34)		3.30 (12.5)				1.62 (6.12)	1.77 (6.70)
4D16	2.67 (10.1)		5.26 (19.9)				2.56 (9.69)	2.75 (10.4)
4D17	2.75 (10.4)		5.42 (20.5)				2.64 (10.0)	2.85 (10.8)
4D18	2.83 (10.7)		5.55 (21.0)		1.22 (4.61)	Grease	2.72 (10.3)	2.93 (11.1)
4E17	3.86 (14.6)		7.61 (28.8)				3.46 (13.1)	4.25 (16.1)
4E18	3.88 (14.7)		7.69 (29.1)				3.49 (13.2)	4.28 (16.2)
4E19	4.15 (15.7)		8.03 (30.4)				3.75 (14.2)	4.54 (17.2)
4F18	5.28 (20.0)		10.41 (39.4)		1.92 (7.28)	Grease	4.89 (18.5)	5.65 (21.4)
4F19	5.49 (20.8)		10.73 (40.6)				5.10 (19.3)	5.86 (22.2)

Table 26. Double Reduction Approximate Oil Quantity

Units: US liquid gallon (*liter*) **Note: Output = Bevel Gear Portion Input = Cyclo® Portion**

Bevel Gear Unit Size	Mounting Configuration							
	Y1 	Y3 	Y2 	Y4 		Y5 	Y6 	
	Output		Input					
4A10DA	0.44 (1.65)		0.85 (3.20)		0.30 (1.13)	Grease	0.37 (1.39)	0.49 (1.87)
4A12DA	0.46 (1.74)		0.89 (3.38)				0.39 (1.48)	0.52 (1.96)
4A12DB	0.47 (1.78)		0.91 (3.43)				0.40 (1.52)	0.53 (2.00)
4B12DA	0.88 (3.32)		1.73 (6.53)				0.89 (3.37)	0.86 (3.26)
4B12DB	0.89 (3.36)		1.74 (6.57)		0.45 (1.72)	Grease	0.90 (3.41)	0.87 (3.30)
4B14DA	0.93 (3.52)		1.85 (7.00)				0.94 (3.57)	0.91 (3.46)
4B14DB	0.94 (3.56)		1.86 (7.04)				0.95 (3.61)	0.92 (3.50)
4B14DC	0.95 (3.61)		1.89 (7.17)				0.97 (3.66)	0.94 (3.55)
4C14DA	1.47 (5.55)		2.96 (11.2)		0.72 (2.72)	Grease	1.41 (5.33)	1.56 (5.91)
4C14DB	1.48 (5.59)		2.96 (11.2)				1.42 (5.37)	1.57 (5.95)
4C14DC	1.49 (5.64)		2.99 (11.3)				1.43 (5.42)	1.59 (6.00)
4C16DA	1.59 (6.03)		3.12 (11.8)				1.53 (5.81)	1.69 (6.39)
4C16DB	1.61 (6.08)		3.14 (11.9)		1.22 (4.61)	Grease	1.55 (5.86)	1.70 (6.44)
4C17DA	1.69 (6.41)		3.33 (12.6)				1.64 (6.19)	1.79 (6.77)
4C17DB	1.70 (6.44)		3.33 (12.60)				1.67 (6.32)	1.80 (6.80)
4C17DC	1.75 (6.64)		3.35 (12.70)				1.70 (6.42)	1.82 (6.90)
4D16DA	2.67 (10.1)		5.28 (20.0)		1.22 (4.61)	Grease	2.58 (9.76)	2.77 (10.5)
4D16DB	2.67 (10.1)		5.28 (20.0)				2.59 (9.81)	2.80 (10.6)
4D16DC	2.72 (10.3)		5.31 (20.1)				2.59 (9.82)	2.83 (10.7)

Table 26. Double Reduction Approximate Oil Quantity, continued

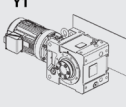
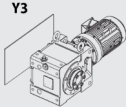
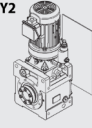
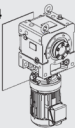
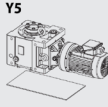
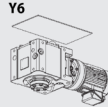
Units: US liquid gallon (*liter*) **Note: Output** = Bevel Gear Portion **Input** = Cyclo® Portion

Bevel Gear Unit Size	Mounting Configuration						
	Y1 	Y3 	Y2 	Y4 	Y5 	Y6 	
			Output		Input		
4D17DA	2.69 (10.2)		5.28 (20.0)	1.22 (4.61)	Grease	2.59 (9.81)	2.80 (10.6)
4D17DB	2.77 (10.5)		5.44 (20.6)			2.69 (10.2)	2.88 (10.9)
4D17DC	2.83 (10.7)		5.47 (20.7)			2.72 (10.3)	2.91 (11.0)
4D18DA	2.85 (10.8)		5.57 (21.1)			2.77 (10.5)	2.96 (11.2)
4D18DB	3.09 (11.7)		5.65 (21.4)			3.01 (11.4)	3.20 (12.1)
4E17DA	3.86 (14.6)		7.61 (28.8)	1.65(6.26)	Grease	3.46 (13.1)	4.25 (16.1)
4E17DB	3.88 (14.7)		7.63 (28.9)			3.49 (13.2)	4.28 (16.2)
4E17DC	3.91 (14.8)		7.66 (29.0)			3.51 (13.3)	4.31 (16.3)
4E18DA	3.91 (14.8)		7.74 (29.3)			3.51 (13.3)	4.31 (16.3)
4E18DB	4.15 (15.7)		7.82 (29.6)			3.75 (14.2)	4.54 (17.2)
4E19DA	4.62 (17.5)		8.19 (31.0)	1.92 (7.28)	Grease	4.23 (16)	5.02 (19.0)
4E19DB	4.68 (17.7)		8.19 (31.0)			4.28 (16.2)	5.07 (19.2)
4F18DA	5.31 (20.1)		10.46 (39.6)			4.91 (18.6)	5.68 (21.5)
4F18DB	5.55 (21.0)		10.54 (39.9)			5.15 (19.5)	5.92 (22.4)
4F19DA	5.97 (22.6)		10.88 (41.2)			5.57 (21.1)	6.34 (24.0)
4F19DB	6.02 (22.8)		10.88 (41.2)	5.63 (21.3)	6.39 (24.2)		

Lubrication, continued

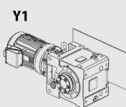
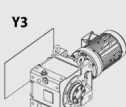
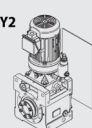
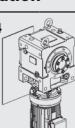
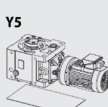
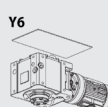
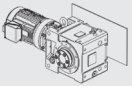
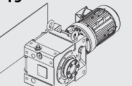
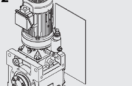
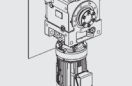
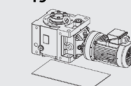
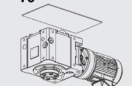
Oil Supply and Discharge Procedures

Oil Supply Procedure



• Always stop the unit before adding oil



- Oil level may drop during operation, depending on the oil viscosity, temperature and direction of rotation. Additional oil is not necessary. Check the oil level when the unit is stopped to ensure that it has the correct amount of oil.
- It may take some time for the oil to settle when the oil viscosity is high. Be careful not to add too much oil.
- There may be two different oil fill locations for some combinations; refer to oil fill/ drain locations figure for details.
- Consider implementing an oil analysis program to ensure lubricant continues to operate at peak performance. Follow your lubrication provider's oil analysis recommendations to ensure reducer performance.
- Always consult factory and warehouses for overhaul of gearmotors and reducers. Familiarity with Cyclo® products is necessary for proper overhaul.

1. Remove the 'Oil filler plug', and 'Oil fill air vent' as referenced in Figure 2.
2. Slowly add oil while checking the level through the oil gauge.
3. After the oil has settled, make sure **the level is visible** in the oil gauge.
4. Re-install 'Oil filler plug', and 'Oil fill air vent' after wrapping it with sealing compound or tape.

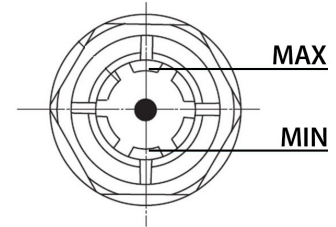
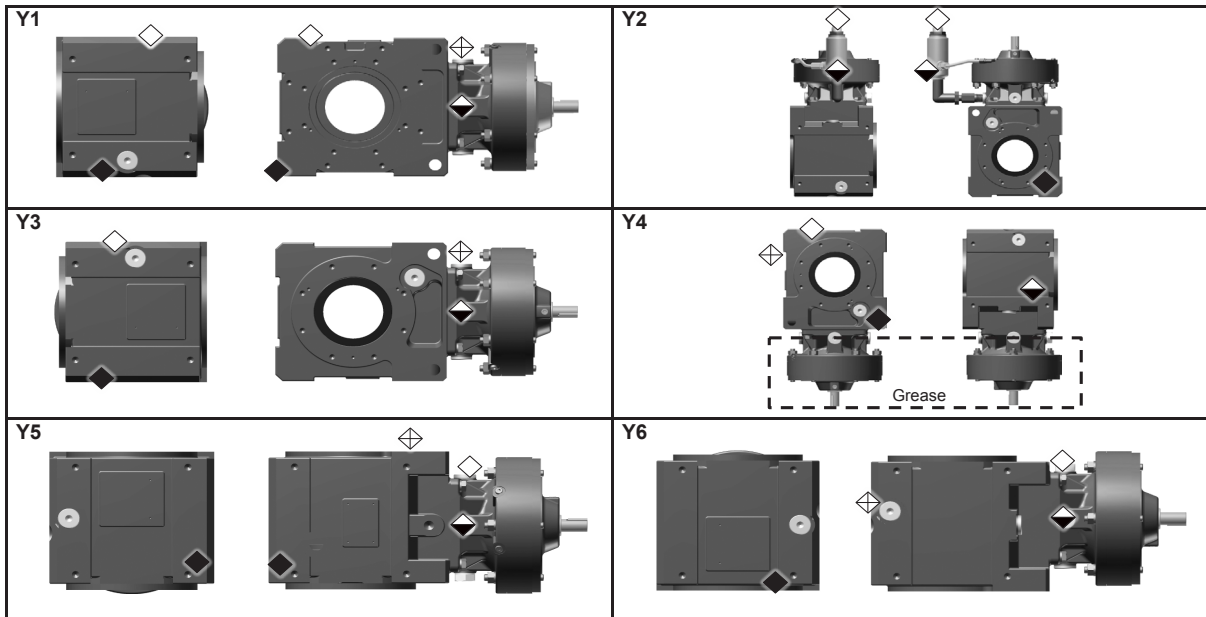

Table 27. Oil Change Intervals

Task	Change interval		Conditions of use
Supply of Oil	At installation		All
Oil Change	First Change	500 hrs operation or 6 months, whichever comes first.	All
	Second change and thereafter	2500 hrs operation or 6 months, whichever comes first. 5000 hrs operation or 1 year, whichever comes first.	When case oil temperature is 158° F (70° C) or higher When case oil temperature is lower than 158° F (70° C)

Note: Units supplied with Mobil SHC Gear Hi-Shock 150 may double the oil change intervals.

Figure 2. Oil Fill/Drain Locations



◇=Oil filler plug ◇=Oil level (Oil gauge) ◆=Oil drain plug ◇=Oil fill air vent

Oil Discharge Procedure

1. Remove the drain plug as shown in Figure 2, to discharge oil.
2. Properly discard or recycle lubricant according to applicable regulations.
3. Replace the drain plug after wrapping it with sealing compound or tape.

Grease Quantities



- Grease quantities listed in this section are for the Cyclo® portion of the reducer/gearmotor.
- The Bevel portion is always oil lubricated unless otherwise specified at time of order entry.
- Refer to the Oil Quantities section, Tables 25 & 26, for Bevel portion oil quantities.
- Installing grease into Bevel Gear portion will result in damage to the unit.

The Cyclo® (input) portion of **only Y4 double reduction** units is grease lubricated at the factory. Additional grease is not required before initial start-up. All assemblies other than Y4 have oil lubricated Cyclo® portions. The following tables are provided for user rebuild or refurbishment reference.

Table 28. Single Reduction Approximate Grease Quantity

Units: ounce (*gram*)

Unit Size	Unit Lubrication Portion	Lube Quantity oz. (<i>gram</i>)
		Y4  only
4A100/105	Cyclo®	4.24 (120)
4A110/115		6.71 (190)
4A120/125		8.83 (250)
4A140/145		15.89 (450)
4B120/125		8.83 (250)
4B140/145		15.89 (450)
4B160/165		26.48 (750)
4C140/145		15.89 (450)
4C160/165		26.48 (750)
4C170/175		35.3 (1000)
4D160/165		26.48 (750)
4D170/175		35.3 (1000)
4E170/175		35.3 (1000)
4F180/185		38.8 (1100)
4F190/195		52.9 (1500)

Table 29. Double Reduction Approximate Grease Quantity

Units: ounce (*gram*)

Unit Size	Cyclo® Stage	Lube Quantity oz. (<i>gram</i>)
		Y4  only
4A10DA	First (Input)	0.88 (25)
	Second	4.24 (120)
4A12DA	First (Input)	0.88 (25)
	Second	8.83 (250)
4A12DB	First (Input)	2.12 (60)
	Second	8.83 (250)
4B12DA	First (Input)	0.88 (25)
	Second	8.83 (250)
4B12DB	First (Input)	2.12 (60)
	Second	8.83 (250)
4B14DA	First (Input)	0.88 (25)
	Second	15.86 (450)
4B14DB	First (Input)	2.12 (60)
	Second	15.86 (450)
4C14DA	First (Input)	0.88 (25)
	Second	15.86 (450)
4C14DB	First (Input)	2.12 (60)
	Second	15.86 (450)
4C14DC	First (Input)	4.24 (120)
	Second	15.86 (450)
4C16DA	First (Input)	2.12 (60)
	Second	26.48 (750)
4C16DB	First (Input)	4.24 (120)
	Second	26.48 (750)

Lubrication, continued

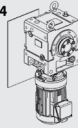
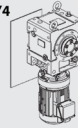
Grease Replenishment and Draining Procedure, Grease Replacement

Grease Replenishment and Draining Procedure

Procedure for adding grease to grease-lubrication models (excluding maintenance-free models)

1. Remove the grease discharge plug from the outside cover.
2. Add grease with a grease gun from the grease nipple in the inside cover section or motor connection cover.
3. Insert the grease discharge plug.



Add grease while manually rotating the input shaft to ensure proper, uniform circulation. Add grease slowly, to prevent internal pressure and possible seal damage. Do not add more grease than the amount shown in Table 28 and 29. Adding too much grease may cause the grease temperature to rise, or force the grease to leak into the motor.

Always consult factory and warehouses for overhaul of gearmotors and reducers. Familiarity with Cyclo® products is necessary for proper overhaul.

Table 30. Grease Replenishment Intervals

Hours of operation	Replenishment interval	Remarks
10 hr. max./day	3 - 6 months	Shorten the supply interval when the operating conditions are severe or the frame size is large
10 - 24 hr. max./day	500 - 1000 hours	

Table 31. Grease Replacement Intervals

Change Interval	Remarks
Every 20,000 hrs or 3-5 years	Shorten the supply interval when the operating conditions are severe or the frame size is large

Grease Replacement

- Maintenance free units may be safely operated for an extended time because it is sealed with maintenance free grease. Tables 28 & 29 are provided for generalized reference.



- Adequate care should be taken to ensure the lubricant continues to meet the specified lubrication characteristics.
- If refurbishment or rebuild is required, do not add more grease than the amount shown in Tables 28 and 29.
- Adding too much grease may cause the grease temperature to rise or force the grease to leak into the motor.



- Consider implementing a lube analysis program to ensure lubricant continues to operate at peak performance.
- Follow your lubrication providers analysis recommendations to ensure reducer performance.
- Always consult factory and warehouses for overhaul of gearmotors and reducers. Experience is necessary for proper overhaul.

Y2 Oil Fill & Drain Procedures

Oil Fill Process

Affected Unit Sizes

This document is intended for all Cyclo® Bevel Buddybox® (BBB) 4 series units built in the Y2 mounting (motor up) configuration. Images contained within the document show a single reduction input stage, however the process remains the same for double and triple reduction product offerings.

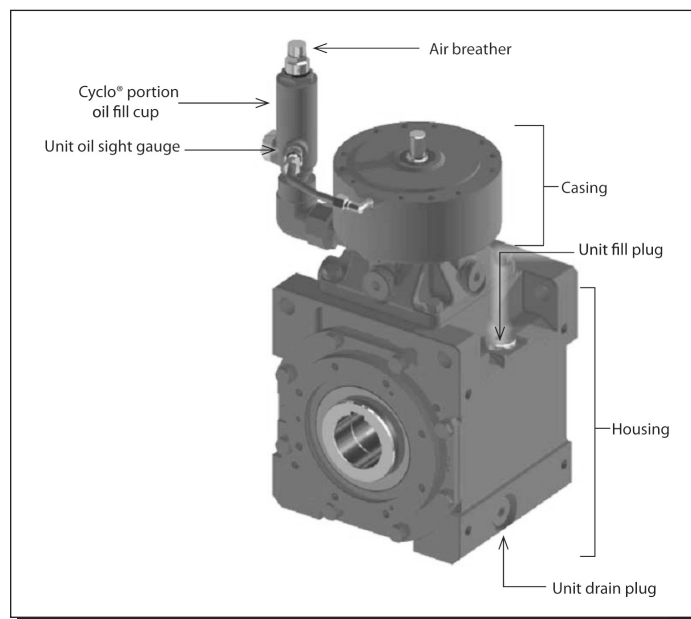

Oil Fill Process

CAUTIONARY NOTE:



- Use only those lubricating oils approved by Sumitomo Drive Technologies for use in the Cyclo® Bevel Buddybox®.
- Use the appropriate grade of lubricating oil based on ambient operating conditions of the application.
- Refer to the Sumitomo product catalog and/or Operating & Maintenance manual for a list of Sumitomo approved lubricating oils.
- Prior to beginning the fill process, ensure the Unit Drain Plug is in place and adequately tightened.

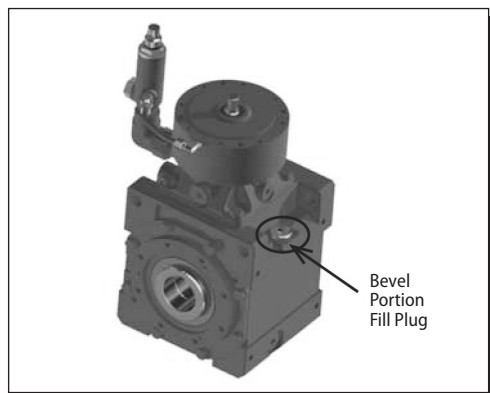

1

Identify the bevel portion oil fill plug on the bevel gear housing. Carefully remove the plug and put aside for reinsertion after oil fill is complete.

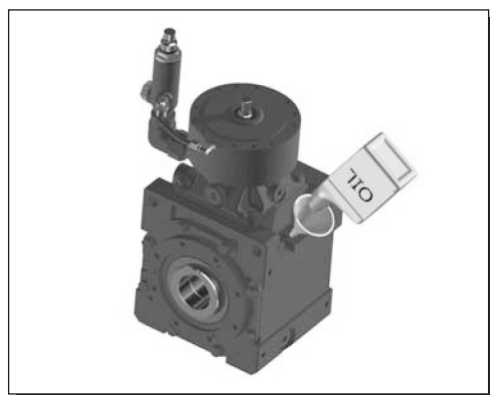

2

Fill the bevel portion with the appropriate type and grade of oil.

The bevel portion is considered full when the oil level reaches the oil fill port.

Once fill is complete, re-install and tighten the oil plug into the fill port

Y2 Oil Fill & Drain Procedures, continued

Oil Fill Process

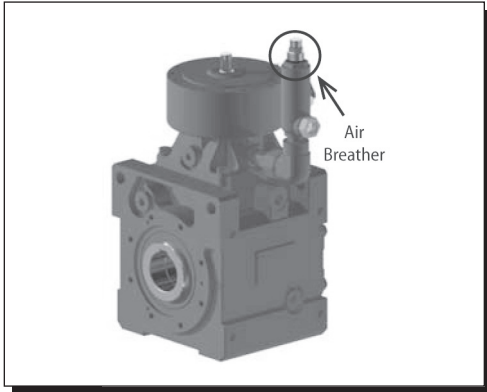

3

Carefully remove the unit Air Breather assembly and put aside for reinsertion after oil fill process is complete.

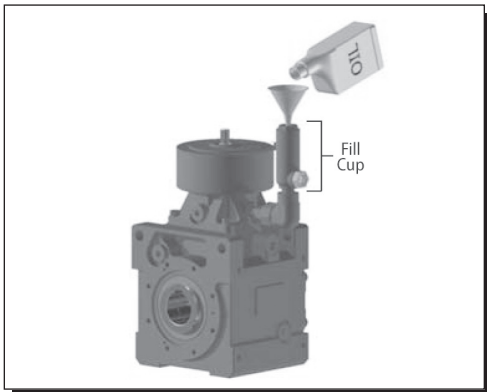

4

Slowly fill the Cyclo® (input) portion with the correct type and grade of oil as used in STEP #2 of this process.

NOTE: The oil fill cup may immediately become full during the process. In such an event, stop the fill process and allow the oil to drain from the cup into the reducer.

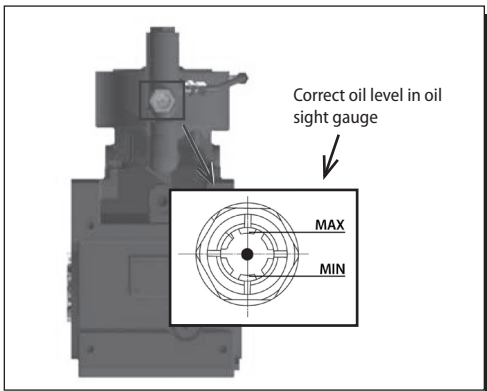

5

The input portion is considered full when the oil level stabilizes in the middle of the oil sight gauge.



Check gauge carefully. Oil film from fill procedure can distort view.

Be sure to check the oil level after a few minutes of operation. Stop equipment and check gauge as shown in step 5. Adjust oil level as required.

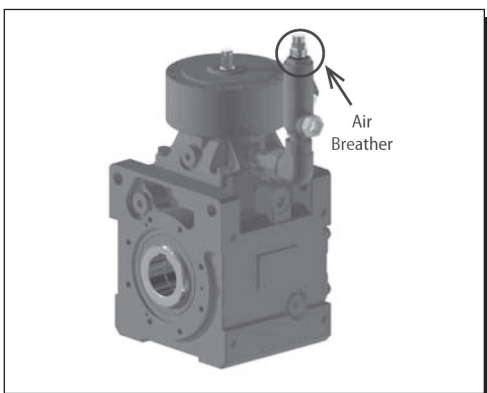

6

Once the input portion of the unit is filled to the correct level with lubricant, carefully reinsert the air breather assembly into the oil fill cup.

Y2 Oil Fill & Drain Procedures, *continued*

Oil Drain Process

Oil Drain Process

CAUTIONARY NOTE:



- Exercise extreme caution when draining the lubricating oil from the Cyclo® Bevel Buddybox® as it may be hot.
- Follow all corporate, local, state and federal government regulations in disposing of the used lubricating oil.

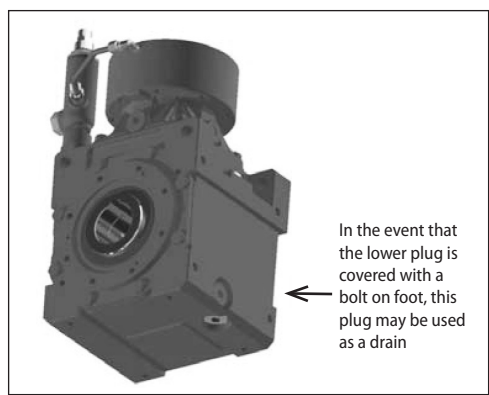

1

Identify the bevel portion oil drain plug on the bevel gear housing.

Carefully remove the plug and put aside for reinsertion after oil fill is complete.

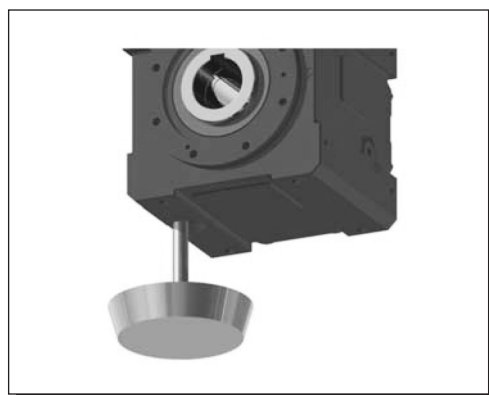

2

Carefully remove the unit air breather assembly and put aside for reinsertion after oil fill process is complete.

Allow used oil to freely flow into an approved lubricant container.

Once the unit is completely drained of oil, reinstall the drain plug and tighten.

Refer to torque tightening values in Table 32.

Table 32. Plug sizes and tightening torque values

Plug Sizes			Torque Value		
Unit Size	Housing	Casing	Size	lb-in	N·m
4A	1/2	1/2	1/2	13.1	17.8
4B	1/2	1/2	3/4	22.1	30.0
4C	3/4	1/2	1	30.4	41.2
4D	3/4	1/2			
4E	3/4	1/2			
4F	3/4	1/2			

Y2 Oil Fill & Drain Procedures, continued

Oil Drain Process

Table 33. BBB4 Y2 Single Reduction Oil Quantity*

Bevel Gear Unit Size	Y2 Configuration Oil Quantity	
	gallon	liter
4A10	0.84	3.17
4A11	0.86	3.26
4A12	0.88	3.35
4A14	1.00	3.77
4B12	1.72	6.50
4B14	1.84	6.97
4B16	2.01	7.61
4C14	2.93	11.1
4C16	3.12	11.8

Bevel Gear Unit Size	Y2 Configuration Oil Quantity	
	gallon	liter
4C17	3.30	12.5
4D16	5.26	19.9
4D17	5.42	20.5
4D18	5.55	21.0
4E17	7.61	28.8
4E18	7.69	29.1
4E19	8.03	30.4
4F18	10.41	39.4
4F19	10.73	40.6

Table 34. BBB4 Y2 Double Reduction Oil Quantity*

Bevel Gear Unit Size	Y2 Configuration Oil Quantity	
	gallon	liter
4A10DA	0.85	3.2
4A12DA	0.89	3.38
4A12DB	0.91	3.43
4B12DA	1.73	6.53
4B12DB	1.74	6.57
4B14DA	1.85	7.00
4B14DB	1.86	7.04
4C14DA	2.96	11.2
4C14DB	2.96	11.2
4C14DC	2.99	11.3

Bevel Gear Unit Size	Y2 Configuration Oil Quantity	
	gallon	liter
4C16DA	3.12	11.8
4C16DB	3.14	11.9
4C17DA	3.33	12.6
4D16DA	5.28	20.0
4D16DB	5.28	20.0
4D17DB	5.44	20.6
4D17DC	5.47	20.7
4E17DA	7.61	28.8
4E17DB	7.63	28.9
4E17DC	7.66	29.0

* All oil quantities are estimates

Wiring Guidelines

This section details wiring for standard Sumitomo three-phase motors and brakemotors. If using a motor manufactured by a company other than Sumitomo, please refer to that manufacturer's instruction manual for wiring, operating and maintenance details. When wiring motors into the power supply, Sumitomo recommends the use of terminal rings to facilitate the connection:

Figure 3. Terminal Ring Wiring Connection

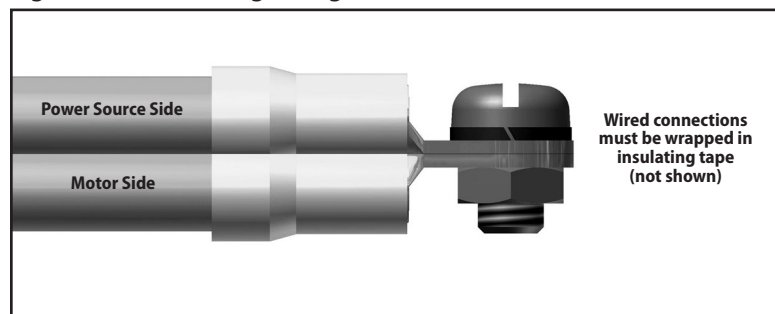

- Do not handle the unit when cables are live. Be sure to turn-off the power; otherwise electric shock may result.
- Connect the power cables to the unit according to the connection diagram shown inside the terminal box or in the maintenance manual; otherwise electric shock or fire may result.
- Correctly ground the grounding bolt; otherwise electric shock may result.
- Keep all wiring and electrical parts dry and moisture free.
- Follow local electrical codes and regulations when wiring; otherwise burning, electrical shock, injury and/or fire may result.
- The motor is not equipped with an overload device. Sumitomo strongly recommends that another protective device (i.e.: ground fault interrupters, etc.), in addition to an overload device, be installed in order to prevent burning, electric shock, personal injury and/or fire.
- For single phase motors, exercise caution so as to not damage the vinyl cover of the starting capacitor, otherwise shock may result.
- For brakemotors, do not electrify a brake coil continuously when the motor is stopped otherwise the brake coil may burn and fire may result.



- For brakemotors, install the rectifier where the temperature is less than 140°F (60°C)
- Long wires cause the voltage to drop. Select cables with appropriate diameter so that the voltage drop will be less than 2%.
- After wiring the motor, check that the terminal box mounting bolts are tight.

Measuring Insulation Resistance

When measuring insulation resistance, disconnect the motor from the control panel. Check the motor separately.



Never touch the terminals when measuring insulation resistance otherwise electrical shock may occur.

Measure the insulation resistance before wiring. Insulation resistance varies according to the motor voltage, insulation type, coil temperature, humidity, length of operation, test electrification time, etc.

Under most conditions, the insulation resistance exceeds the value shown in this table:

Table 35. Insulation Resistance

Mega-Ohm	Insulation Resistance
500V	1M (Ω)

A drop in resistance may be attributed to poor insulation. In such case, do not turn on the power. Contact the nearest Sumitomo representative, distributor, or sales office.

Motor Wiring, continued

Motor Protection, Motor Wiring Method

Motor Protection



- Use a molded case circuit breaker for protection against short circuit.
- Use an overload protection device that protects the unit against voltage surges.

U.S. Standard Motors Motor Wiring Method



- For additional information please refer to the motor name plate.
- Due to changes in design features, this diagram may not always agree with that on the motor.
- In such cases, connection diagram found inside the conduit box of the motor should be used.

1

Based on motor power, determine if motor is **WYE** or **DELTA** type

2

Wire the motor to the power source using the correct connection type:

Table 36. Typical 230/460V, Three-Phase Wiring Configuration by Motor Type

Motor HP (kW) x P	Standard		AF-Motor		EP.NA-Motor
	Non CSA	CSA	Non CSA	CSA	UL/CSA/CE
1/8 (0.1) x 4	WYE	WYE	WYE	WYE	WYE
1/4 (0.2) x 4					
1/3 (0.25) x 4					
1/2 (0.4) x 4					
3/4 (0.55) x 4					
1 (0.75) x 4					
1.5 (1.1) x 4					
2 (1.5) x 4					
3 (2.2) x 4	DELTA	DELTA	DELTA	DELTA	DELTA
5 (3.7) x 4					
7.5 (5.5) x 4					
10 (7.5) x 4					
15 (11) x 4					
20 (15) x 4					
25 (18.5) x 4					
30 (22) x 4					
40 (30) x 4	—	—	—	—	—
50 (37) x 4	—	—	—	—	—
60 (60) x 4	—	—	—	—	—
75 (56) x 4	—	—	—	—	—

Figure 4. Three-Phase WYE Connection Motor

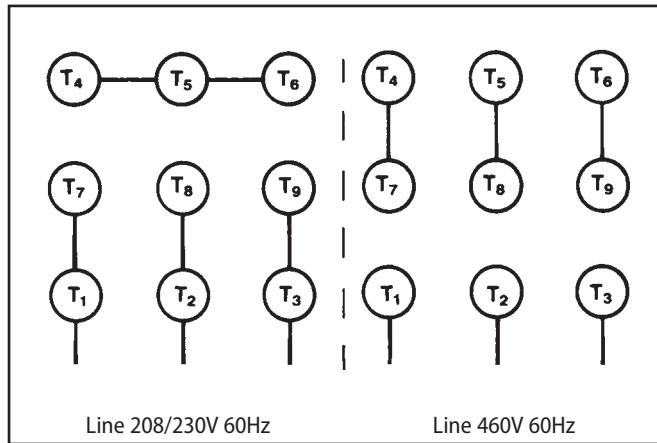

Figure 5. Three-Phase DELTA connection Motor

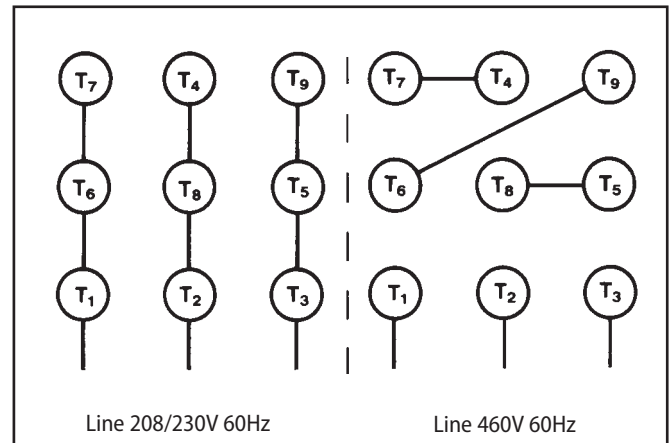

Figure 6. Three-Phase Motor, 575V, 60Hz

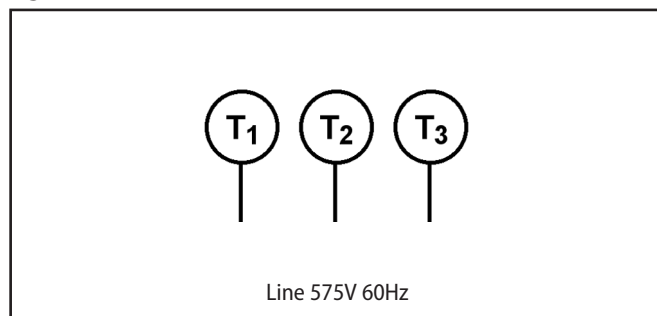
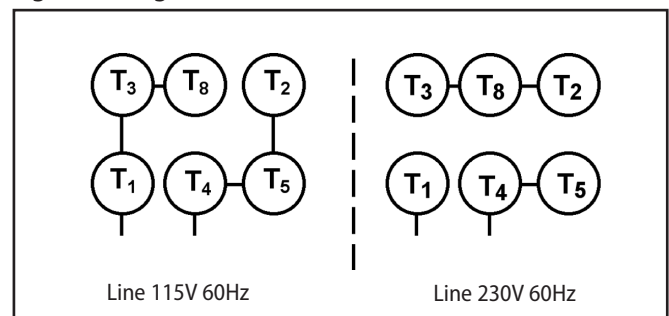

Figure 7. Single-Phase Motor, 115/230V, 60Hz



Motor Wiring, continued**Motor Wiring Method, Brake Wiring****CE Motors****Table 37. Typical 220/380V, Three-Phase Wiring Configuration by Motor Type**

Motor HP (kW) x P	Voltage Configuration	Wiring Configuration
1/8 (0.1) x 4	220/380V, 50Hz Three Phase	DELTA-WYE
1/4 (0.2) x 4		
1/3 (0.25) x 4		
1/2 (0.4) x 4		
3/4 (0.55) x 4		
1 (0.75) x 4		
1.5 (1.1) x 4		
2 (1.5) x 4		
3 (2.2) x 4		
4 (3.0) x 4		
5 (3.7) x 4	380V, 50Hz Three Phase	WYE-Start DELTA-Run
7.5 (5.5) x 4		
10 (7.5) x 4		
15 (11) x 4		
20 (15) x 4		
25 (18.5) x 4		
30 (22) x 4		
40 (30) x 4		

Motor Wiring Method

- For additional information please refer to the motor name plate.
- Due to changes in design features, this diagram may not always agree with that on the motor.
- In such cases, connection diagram found inside the conduit box of the motor should be used.

1Based on motor power, determine if motor is **WYE** or **DELTA** type.**2**

Wire the motor to the power source using the correct connection type:

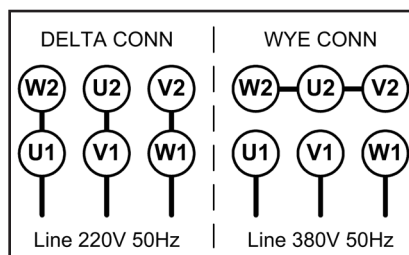
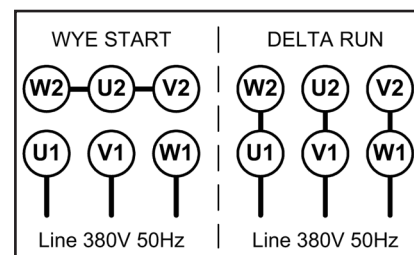
Figure 8. DELTA-WYE Connection Motor**Figure 9. WYE-DELTA Start Connection Motor****Brake Wiring****Varistor Selection**

For wiring of Fast Brake Action, Sumitomo recommends the use of a Varistor (VR). Refer to Table 38 to assist in the selection of the appropriately sized Varistor.

Table 38. Varistor Specifications Table

Operating Voltage		190 - 230V	380-460V	575V
Varistor Rated Voltage Varistor Voltage		AC260-300V 430-470V	AC510V 820V	AC604V 1000V
Rated Watts	FB01A, 02A FB-05A FB-1D, 1E FB-2D, 3D, 1HE, 2E, 3E FB-5B, 8B, 5E, 8E FB10B, 15B, 10B1, 15B1, 10E, 15E	Over 0.4W Over 0.4W Over 0.6W Over 1.5W Over 1.5W Over 1.5W Over 1.5W	Over 0.4W Over 0.4W Over 0.6W Over 1.5W Over 1.5W Over 1.5W Over 1.5W	Over 0.4W Over 0.4W Over 0.6W Over 1.5W Over 1.5W Over 1.5W Over 1.5W
	FB-20, 30			Over 1.5W

Motor Wiring, continued

U.S. Standard and CSA Approved Motor Brake Wiring

U.S. Standard and CSA Approved Motor Brake Wiring

The brake portion (if supplied) of the motor may be wired using one of the following methods

Models FB-01A through FB-15B/FB-15E

Figure 10. Normal Brake Action, 230V, 575V

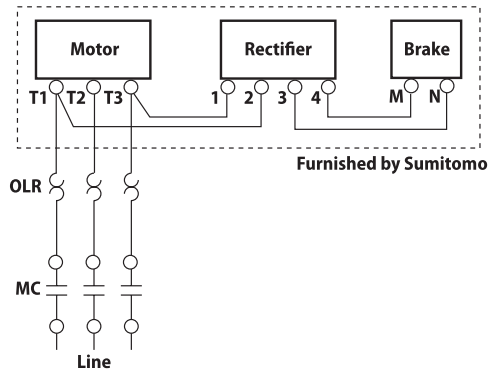

Figure 11. Fast Brake Action, 230V

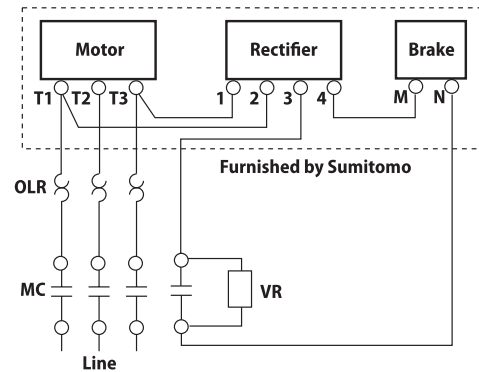

Figure 12. Normal Brake Action, 460V

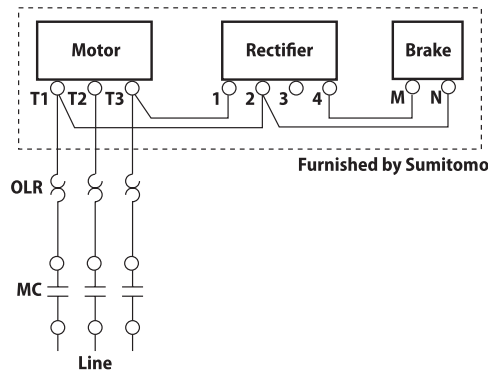
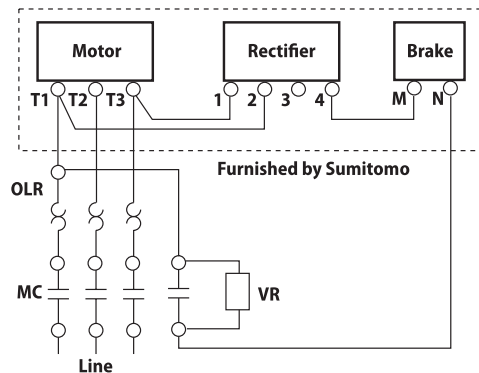

Figure 13. Fast Brake Action, 460V, 575V



- MC: Electromagnetic Relay
- MCB: Magnetic Circuit Breaker
- OLR: Overload or Thermal Relay
- VR: Varistor (protective device)^[1]

Note: [1] Refer to Varistor Specifications Table

U.S. Standard and CSA Approved Motor Brake Wiring

The brake portion (if supplied) of the motor may be wired using one of the following methods

Models FB-01A through FB-15B/FB-15E with Inverter

Figure 14. Normal Brake Action, 230V

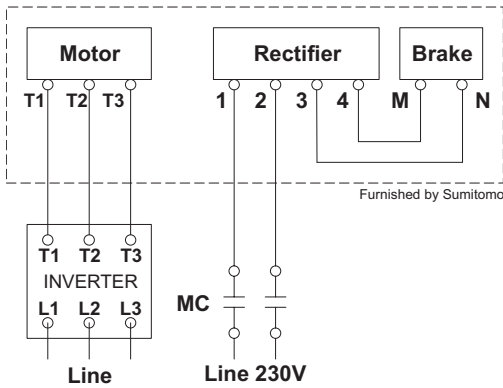

Figure 15. Fast Brake Action, 230V Brake

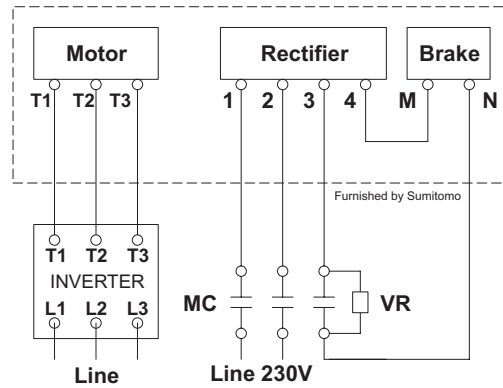

Figure 16. Normal Brake Action, 460V, 575V Brake

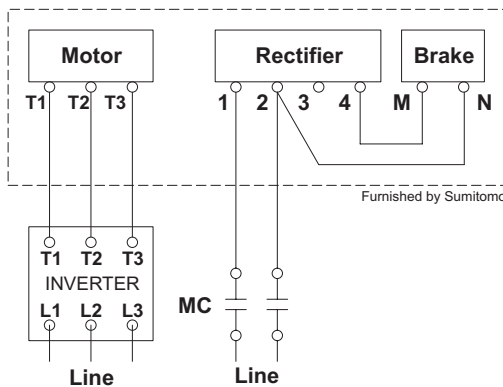
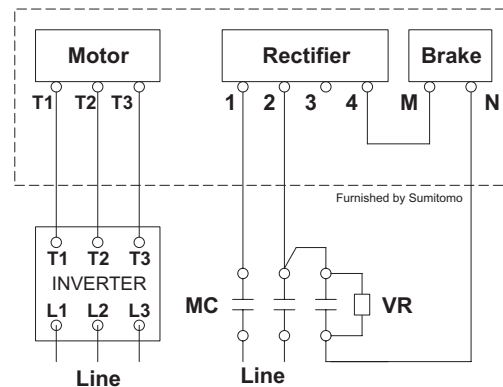
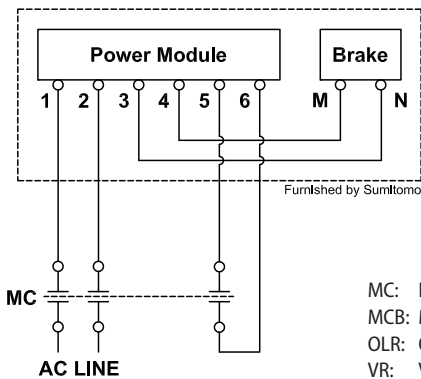

Figure 17. Fast Brake Action, 460V, 575V Brake



Models FB-20 / FB-30

Figure 18. FB-20 and FB-30 Brake Wiring, 480VAC or less



MC: Electromagnetic Relay
 MCB: Magnetic Circuit Breaker
 OLR: Overload or Thermal Relay
 VR: Varistor (protective device)^[1]

Note: [1] Refer to Varistor Specifications Table

Figure 19. FB-20 and FB-30 Brake Wiring, 575VAC

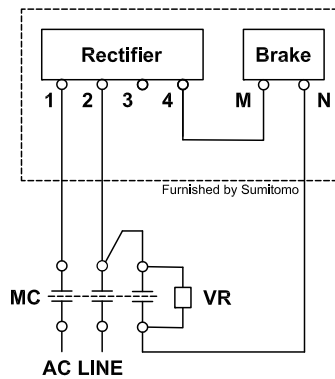

Motor Wiring, continued

CE Motor Brake Wiring

CE Motor Brake Wiring

Models FB-01A through FB-5B/FB-5E, 220/380V, 50Hz

Figure 20. Normal Brake Action, 220V Motor 220V Brake

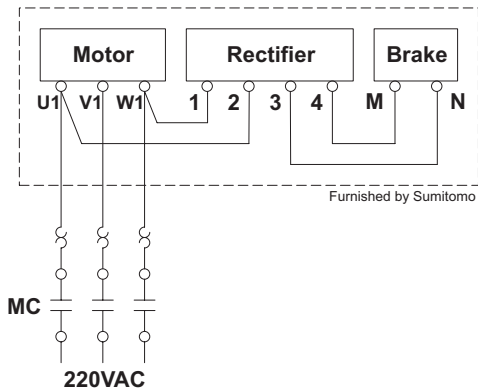

Figure 21. Fast Brake Action, 220V Motor 220V Brake

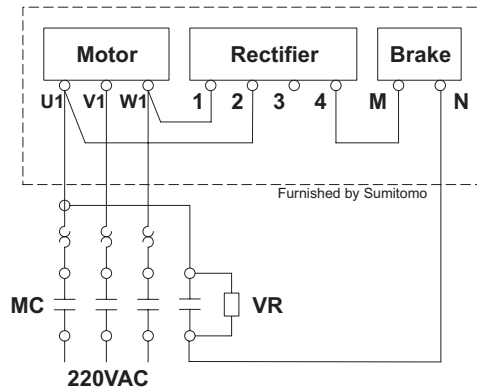

Figure 22. Normal Brake Action, 380V Motor, 220V Brake, Tapped

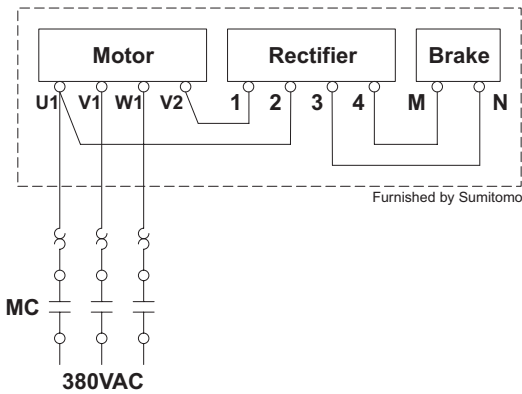

Figure 23. Fast Brake Action, 380V Motor, 220V Brake, Tapped

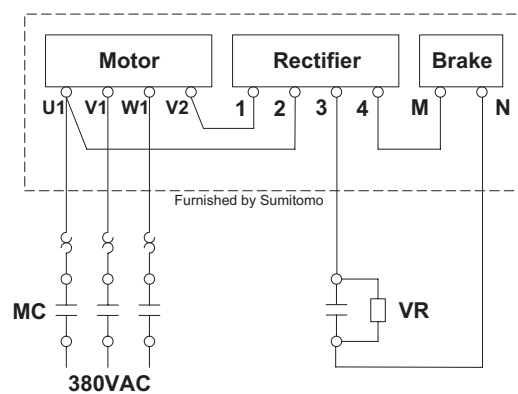

Figure 24. Normal Brake Action, 380V Motor, 220V Brake, Separated

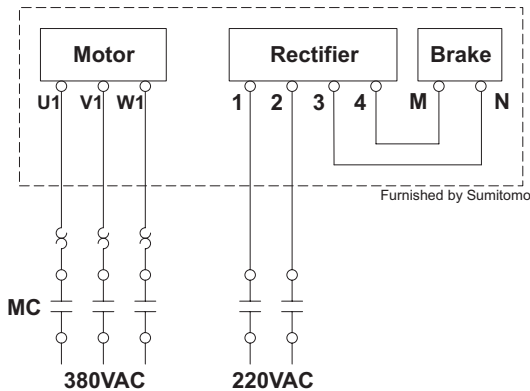
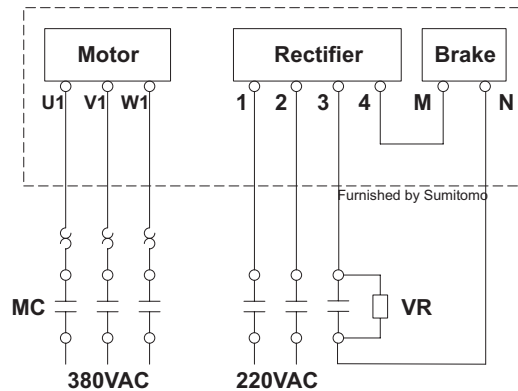

Figure 25. Fast Brake Action, 380V Motor, 220V Brake, Separated



- MC: Electromagnetic Relay
- MCB: Magnetic Circuit Breaker
- OLR: Overload or Thermal Relay
- VR: Varistor (protective device)^[1]

Note: [1] Refer to Varistor Specifications Table

Motor Wiring, continued

CE Motor Brake Wiring

Models FB-8B/FB-8E through FB-15B/FB-5E

Figure 26. Normal Brake Action, 380V Motor, 380V Brake

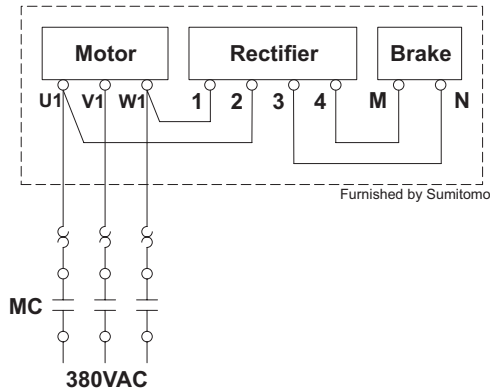
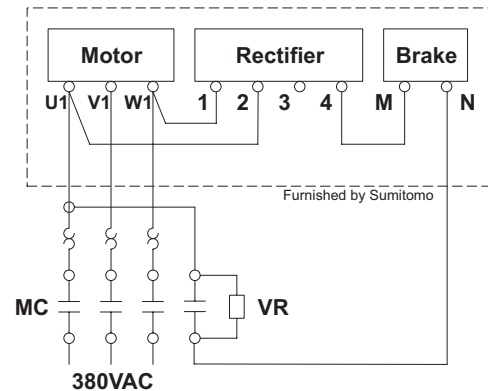

Figure 27. Fast Brake Action, 380V Motor, 380V Brake



CE Motors Models FB-01A through FB-15B/FB-15E with Inverter

Figure 28. Normal Brake Action

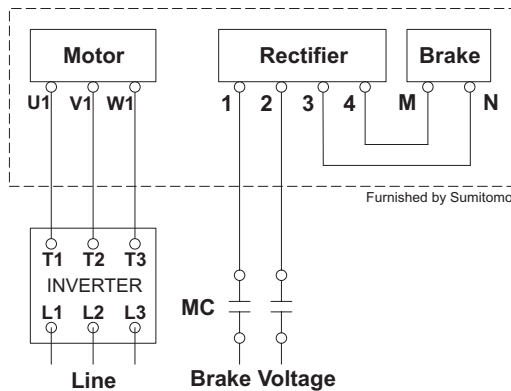
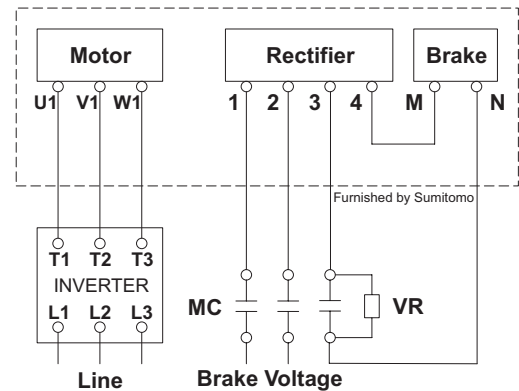

Figure 29. Fast Brake Action



CE Motor Brake Wiring

Models FB-20 / FB-30

Figure 30. FB-20 and FB-30 Brake Wiring, 480VAC or less

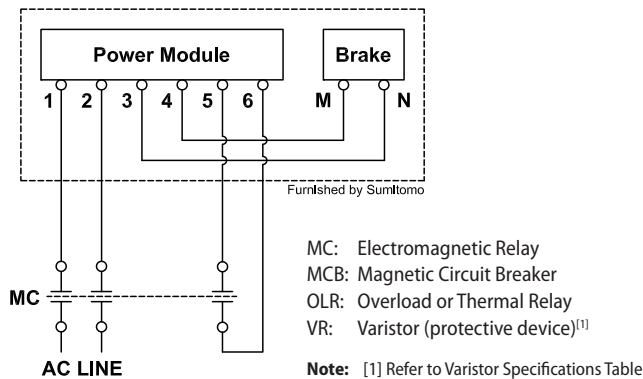

Table 26. Standard CE Motor, Motor / Brake Voltage Table

HP (kW) x P	Brake Model	Motor Voltage	Brake Voltage
1/8 (0.1) x 4	FB-01A	220/380V, 50Hz	220V, 50Hz
1/4 (0.2) x 4	FB-02A		
1/3 (0.25) x 4	FB-05A		
1/2 (0.4) x 4	FB-05A		
3/4 (0.55) x 4	FB-1D/FB-1E		
1 (0.75) x 4	FB-2D/FB-1HE/FB-2E		
1.5 (1.1) x 4			
2 (1.5) x 4	FB-3D/FB-3E		
3 (2.2) x 4	FB-5B/FB-4E/FB-5E		
4 (3) x 4			
5 (3.7) x 4	FB-8B/FB-8E	380V, 50Hz	380V, 50Hz
7.5 (5.5) x 4	FB-10B/FB-10E		
10 (7.5) x 4	FB-15B/FB-15E		
15 (11) x 4	FB-15B/FB-15E		

Motor Wiring, continued**Brake Rectifiers and Power Modules****Brake Rectifiers and Power Modules****Table 40. Standard Brake Rectifiers**

Brake Type	Motor HP (kW) x P	230V/460V Rectifier		575V Rectifier	
		Model Number	Part Number	Model Number	Part Number
FB-01A	1/8 (0.1) x 4	25FW-4FB3	EW107WW-01	10F-6FB3	EW104WW-01
FB-02A	1/4 (0.2) x 4 1/3 (0.25) x 4				
FB-05A	1/2 (0.4) x 4				
FB-1D, 1E	3/4 (0.55) x 4 1 (0.75) x 4				
FB-2D, 1HE, 2E	1.5 (1.1) x 4 2 (1.5) x 4				
FB-3D, 3E	3 (2.2) x 4				
FB-5B, 5E	5 (3.7) x 4				
FB-8B, 8E	7.5 (5.5) x 4				
FB-10B, 10B1, 10E	10 (7.5) x 4				
FB-15B, 15B1, 15E	15 (11) x 4				
FB-20	20 (15) x 4				
FB-30	25 (18.5) x 4 30 (22) x 4 40 (30) x 4				

Table 41. Brake Rectifiers for CE Motors

Brake Type	Motor HP (kW) x P	220V Rectifier		380V Rectifier	
		Model Number	Part Number	Model Number	Part Number
FB-01A	1/8 (0.1) x 4	10F-2FB2	MP983WW-01	Consult Factory	Consult Factory
FB-02A	1/4 (0.2) x 4 1/3 (0.25) x 4				
FB-05A	1/2 (0.4) x 4				
FB-1D, 1E	3/4 (0.55) x 4 1 (0.75) x 4				
FB-2D, 1HE, 2E	1.5 (1.1) x 4 2 (1.5) x 4				
FB-3D, 3E	3 (2.2) x 4				
FB-5B, 4E, 5E	4 (3.0) x 4 5 (3.7) x 4				
FB-8B, 8E	7.5 (5.5) x 4	Consult Factory	Consult Factory	05F-4FB2	MP985WW-01
FB-10B, 10B1, 10E	10 (7.5) x 4			15F-4FB1	EW397WW-01
FB-15B, 15B1, 15E	15 (11) x 4				

Table 42. Brake Power Modules

Brake Type	Motor HP (kW) x P	170 ~ 300VAC Module		380 ~ 480VAC Module	
		Model Number	Part Number	Model Number	Part Number
FB-20	20 (15) x 4	13SR-2	ES075WW-01	10SR-4	MQ003WW-01
FB-30	25 (18.5) x 4 30 (22) x 4 40 (30) x 4				

Figure 31. Cyclo® BBB4 Reducer Parts

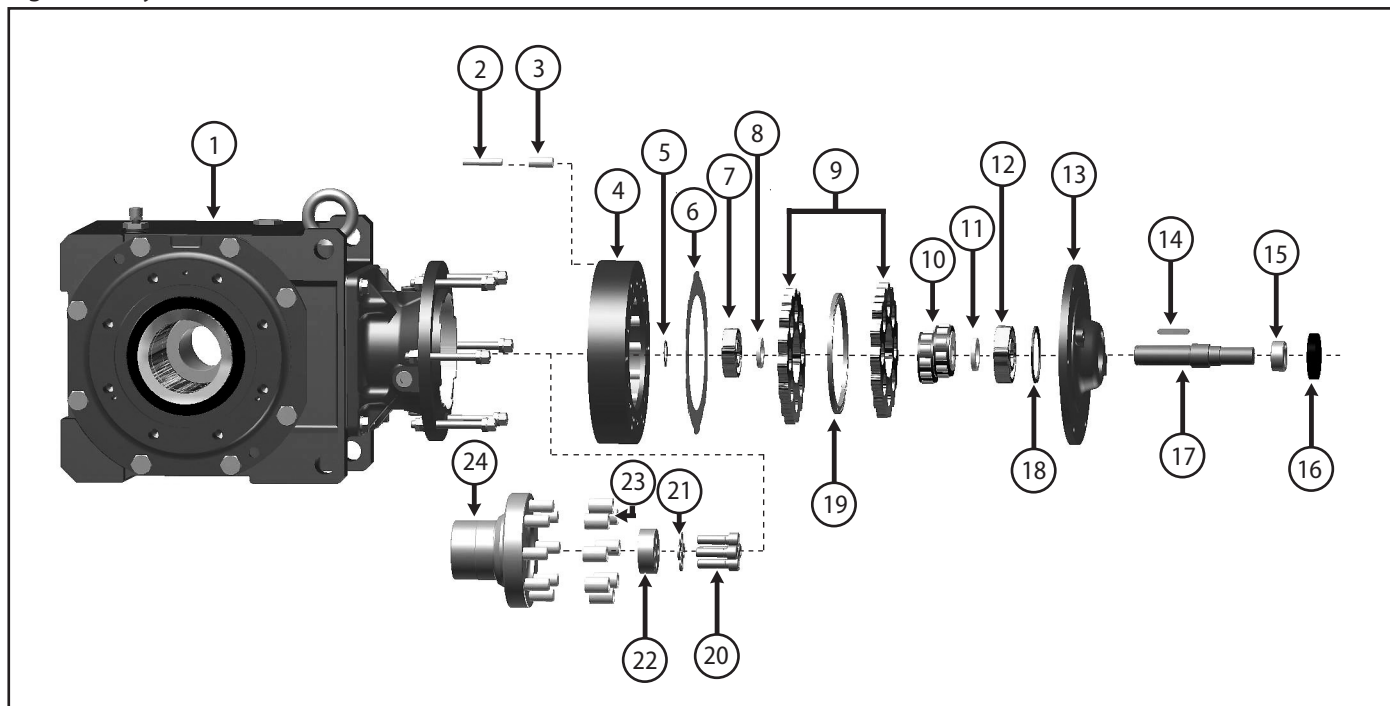

Table 43. Cyclo® BBB4 Reducer Parts

Number	Description
1	BBB4 Gear Assembly
2	Cyclo® Ring Gear Housing Pins
3	Cyclo® Ring Gear Housing Rollers
4	Cyclo® Ring Gear Housing
5	Snap Ring
6	Gasket Set
7	High Speed Shaft A Bearing
8	Spacer
9	Cycloid Discs
10	Cyclo® Eccentric Cam Assembly
11	Spacer
12	High Speed Shaft B Bearing

Number	Description
13	Cyclo® High-Speed End Shield
14	Eccentric Key
15	High Speed Shaft Oil Seal Collar
16	High Speed Shaft Oil Seal
17	High Speed Shaft
18	Snap Ring
19	Cycloid Disc Spacer
20	Retaining Bolts
21	Lock Washers
22	End Plate
23	Pin Carrier Rollers
24	Pin Carrier

Parts, continued

Cyclo® Planetary Reduction Component Parts

Cyclo® Planetary Reduction Component Parts (Cyclo® Ratios 11 - 18:1)

Figure 32. Cyclo® Planetary Reduction Component

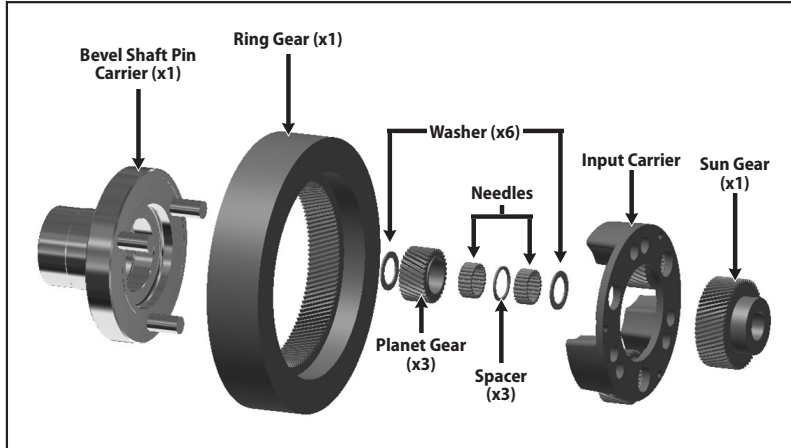

Table 44. Cyclo® Planetary Reduction Component Part Numbers (Ratios 11 - 18:1)

Unit Size	Reduction Ratio (nominal)		Cyclo® Planetary Reduction Part Numbers								
	Overall	Cyclo® Planetary	Reduction Block Set (gears & bearings)	Planet Gear	Ring Gear	Sun Gear	Needles	Spacer	Washer	Input Carrier	Bevel Shaft Pin Carrier
4A100 4A105	11	3:1	931SD610-003G	AN8911G	AN8303G	AN8910G	-	AW5434G	-	-	BL515LG
	13, 14	4:1	931SD610-004G	AN8870G	AN8871G	AN8869G					
	16, 18	5:1	931SD610-005G	AN8305G	AN8306G	AN8304G					
4A120, 4A125 4B120, 4B125	11	3:1	931BB612-003G	AP8712G	CJ584LG	AP8711G	AX2806G-3	AX2543G	AX2761G	CJ244LG	CJ701LG (for 4A) CJ703LG (for 4B)
	13, 14	4:1	931BB612-004G	AP8706G	CJ554LG	AP8705G					
	16, 18	5:1	931BB612-005G	AP8714G	CJ585LG	AP8713G					
4A140, 4A145 4B140, 4B145 4C140, 4C145	11	3:1	931BB614-003G	AP8717G	CJ586LG	AP8716G	AX2807G-3	AX2763G	AX2544G	CJ588LG	CJ702LG (for 4A) CJ704LG (for 4B) CJ706LG (for 4C)
	13, 14	4:1	931BB614-004G	AP8708G	CJ555LG	AP8707G					
	16, 18	5:1	931BB614-005G	AP8719G	CJ587LG	AP8718G					
4B160, 4B165 4C160, 4C165	11	3:1	931BB616-003G	AP8721G	CJ589LG	AP8720G	AX2808G-3	AX2555G	AX2554G	CJ591LG	CJ705LG (for 4B) CJ707LG (for 4C)
	13, 14	4:1	931BB616-004G	AP8710G	CJ556LG	AP8709G					
	16, 18	5:1	931BB616-005G	AP8726G	CJ590LG	AP8722G					
4C170, 4C175 4D170, 4D175 4E170, 4E175	11	3:1	931BB617-003G	AP9278G	CJ993LG	AP9277G	AX3077G-3	AX3061G	AX3060G	CJ996LG	CJ938LG (for 4C) CK009LG (for 4D, 4E)
	13, 14	4:1	931BB617-004G	AP9280G	CJ994LG	AP9279G					
	16, 18	5:1	931BB617-005G	AP9282G	CJ995LG	AP9281G					
4D180, 4D185 4E180, 4E185 4F180, 4F185	11	3:1	931BB618-003G	AP9285G	CJ997LG	AP9284G	AX3077G-3	AX3061G	AX3060G	CK001LG	CJ961LG (for 4D, 4E) CJ965LG (for 4F)
	13, 14	4:1	931BB618-004G	AP9287G		AP9286G				CK002LG	CJ960LG (for 4D, 4E) CJ966LG (for 4F)
	16, 18	5:1	931BB618-005G	AP9289G		AP9288G				CK003LG	CJ959LG (for 4D, 4E) CJ967LG (for 4F)
4E190, 4E195 4F190, 4F195	11	3:1	931BB619-003G	AP9292G	CK004LG	AP9291G	AX3077G-3	AX3061G	AX3060G	CK007LG	CJ962LG (for 4E) CJ968LG (for 4F)
	13, 14	4:1	931BB619-004G	AP9294G		AP9293G				CK006LG	CJ963LG (for 4E) CJ969LG (for 4F)
	16, 18	5:1	931BB619-005G	AP9296G		AP9295G				CK008LG	CJ964LG (for 4E) CJ970LG (for 4F)

Cyclo® BBB4 Reduction Component Part Numbers (Ratios ≥ 19:1)

Figure 34. Cyclo® BBB4 Reduction Components - 4A100 thru 4F195

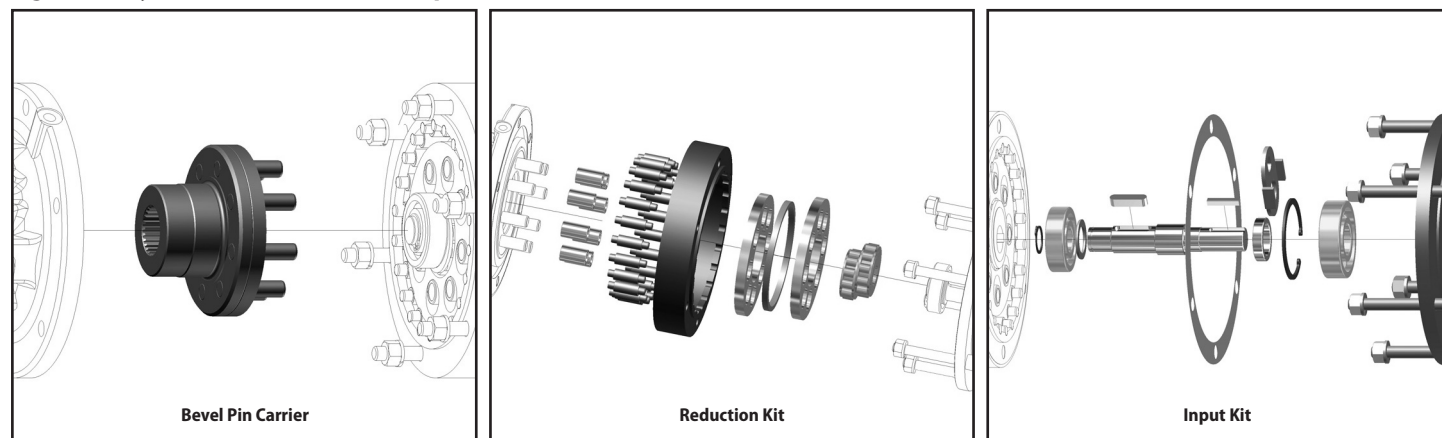

Table 45. Cyclo® BBB4 Reduction Component Part Numbers (Ratios ≥ 19:1)

Unit Size	Reduction Ratio		Part Numbers		
	Overall	Cyclo®	Input Kit	Reduction Kit	Bevel Pin Carrier
4A100 4A105	19, 21	6	D78622	D78675	BL514LG
	22, 25	7		See Note ^[1]	
	26, 28	8		D78676	
	35, 39	11		D78677	
	42, 46	13		D78678	
	48, 53	15		D78679	
	54, 60	17		D78680	
	67, 74	21		D78681	
	80, 88	25		D78682	
	93, 102	29		D78683	
	112, 123	35		D78684	
	138, 151	43		D78685	
	163, 179	51		D78686	
	189, 207	59		D78687	
	227, 249	71		D78688	
	278, 305	89		D78689	
364	104	See Note ^[1]			
364, 417	119	See Note ^[1]			
≥ 424	≥ 121	See Note ^[1]			
4A110 4A115	19, 21	6	D78504	D78520	CJ690LG
	22, 25	7		See Note ^[1]	
	26, 28	8		D78521	
	35, 39	11		D78522	
	42, 46	13		D78523	
	48, 53	15		D78524	
	54, 60	17		D78525	
	67, 74	21		D78526	
	80, 88	25		D78527	
	93, 102	29		D78528	
	112, 123	35		D78529	
	138, 151	43		D78530	
	163, 179	51		D78531	
	189, 207	59		D78532	
	227, 249	71		D78533	
	278, 305	87		D78534	
364	104	See Note ^[1]			
364, 417	119	See Note ^[1]			
≥ 424	≥ 121	See Note ^[1]			

Note: [1] Consult Factory

Parts, continued

Cyclo® Reduction Component Parts

Table 46. Cyclo® BBB4 Reduction Components Part Numbers (Ratios >19:1), continued

Unit Size	Reduction Ratio		Part Numbers			
	Overall	Cyclo®	Input Kit	Reduction Kit	4A12	4B12
					Bevel Pin Carrier	Bevel Pin Carrier
4A120	19, 21	6	D78623	D78690	CJ691LG	CJ693LG
	22, 25	7		See Note ⁽¹⁾		
	26, 28	8		D78691		
	35, 39	11		D78692		
	42, 46	13		D78693		
	48, 53	15		D78694		
	54, 60	17		D78695		
	67, 74	21		D78696		
	80, 88	25		D78697		
	93, 102	29		D78698		
	112, 123	35		D78699		
	138, 151	43		D78700		
	163, 179	51		D78701		
	189, 207	59		D78702		
	227, 249	71		D78703		
	278, 305	89		D78704		
	364	104		See Note ⁽¹⁾		
364, 417	119	See Note ⁽¹⁾				
≥ 424	≥ 121	See Note ⁽¹⁾				

Unit Size	Reduction Ratio		Part Numbers				
	Overall	Cyclo®	Input Kit	Reduction Kit	4A14	4B14	4C14
					Bevel Pin Carrier	Bevel Pin Carrier	Bevel Pin Carrier
4A140	19, 21	6	D78623	D78535	CJ692LG	CJ694LG	CJ696LG
	22, 25	7		See Note ⁽¹⁾			
	26, 28	8		D78536			
	35, 39	11		D78537			
	42, 46	13		D78538			
	48, 53	15		D78539			
	54, 60	17		D78540			
	67, 74	21		D78541			
	80, 88	25		D78542			
	93, 102	29		D78543			
	112, 123	35		D78544			
	138, 151	43		D78545			
	163, 179	51		D78546			
	189, 207	59		D78547			
	227, 249	71		D78548			
	278, 305	89		D78549			
	364	104		See Note ⁽¹⁾			
364, 417	119	See Note ⁽¹⁾					
≥ 424	≥ 121	See Note ⁽¹⁾					

Unit Size	Reduction Ratio		Part Numbers				
	Overall	Cyclo®	Input Kit	Reduction Kit	4B16	4C16	4D16
					Bevel Pin Carrier	Bevel Pin Carrier	Bevel Pin Carrier
4B160	19, 21	6	D78625	D78720	CJ695LG	CJ697LG	CJ699LG
	22, 25	7		See Note ⁽¹⁾			
	26, 28	8		D78721			
	35, 39	11		D78722			
	42, 46	13		D78723			
	48, 53	15		D78724			
	54, 60	17		D78725			
	67, 74	21		D78726			
	80, 88	25		D78727			
	93, 102	29		D78728			
	112, 123	35		D78729			
	138, 151	43		D78730			
	163, 179	51		D78731			
	189, 207	59		D78732			
	227, 249	71		D78733			
	278, 305	89		D78734			
	364	104		See Note ⁽¹⁾			
364, 417	119	See Note ⁽¹⁾					
≥ 424	≥ 121	See Note ⁽¹⁾					

Unit Size	Reduction Ratio		Part Numbers			
	Overall	Cyclo®	Input Kit	Reduction Kit	4C17	4D17, 4E17
					Bevel Pin Carrier	Bevel Pin Carrier
4C170	19, 21	6	D78626	D78735	CJ698LG	CJ700LG
	22, 25	7		See Note ⁽¹⁾		
	26, 28	8		D78794		
	35, 39	11		D78736		
	42, 46	13		D78737		
	48, 53	15		D78738		
	54, 60	17		D78739		
	67, 74	21		D78740		
	80, 88	25		D78741		
	93, 102	29		D78742		
	112, 123	35		D78743		
	138, 151	43		D78744		
	163, 179	51		D78745		
	189, 207	59		D78746		
	227, 249	71		D78747		
	278, 305	89		D78748		
	364	104		See Note ⁽¹⁾		
364, 417	119	See Note ⁽¹⁾				
≥ 424	≥ 121	See Note ⁽¹⁾				

Unit Size	Reduction Ratio		Part Numbers				
	Overall	Cyclo®	Input Kit	Reduction Kit	4D18	4E18	4F18
					Bevel Pin Carrier	Bevel Pin Carrier	Bevel Pin Carrier
4D180	19, 21	6	D78627	See Note ⁽¹⁾	CJ655LG	CJ657LG	
	22, 25	7		See Note ⁽¹⁾			
	26, 28	8		See Note ⁽¹⁾			
	35, 39	11		D78749			
	42, 46	13		D78750			
	48, 53	15		D78751			
	54, 60	17		D78752			
	67, 74	21		D78753			
	80, 88	25		D78754			
	93, 102	29		D78755			
	112, 123	35		D78756			
	138, 151	43		D78757			
	163, 179	51		D78758			
	189, 207	59		D78759			
	227, 249	71		D78760			
	278, 305	87		D78761			

Unit Size	Reduction Ratio		Part Numbers			
	Overall	Cyclo®	Input Kit	Reduction Kit	4E19	4F19
					Bevel Pin Carrier	Bevel Pin Carrier
4E190	19, 21	6	D78628	See Note ⁽¹⁾	CJ956LG	CJ931LG
	22, 25	7		See Note ⁽¹⁾		
	26, 28	8		See Note ⁽¹⁾		
	35, 39	11		D78763		
	42, 46	13		D78763		
	48, 53	15		D78764		
	54, 60	17		D78765		
	67, 74	21		D78766		
	80, 88	25		D78767		
	93, 102	29		D78768		
	112, 123	35		D78769		
	138, 151	43		D78770		
	163, 179	51		D78771		
	189, 207	59		D78772		
	227, 249	71		D78773		
	278, 305	87		D78774		

Note: [1] Consult Factory

Bearings and Oil Seals

Figure 34. Cyclo® BBB4 Bearings and Oil Seals

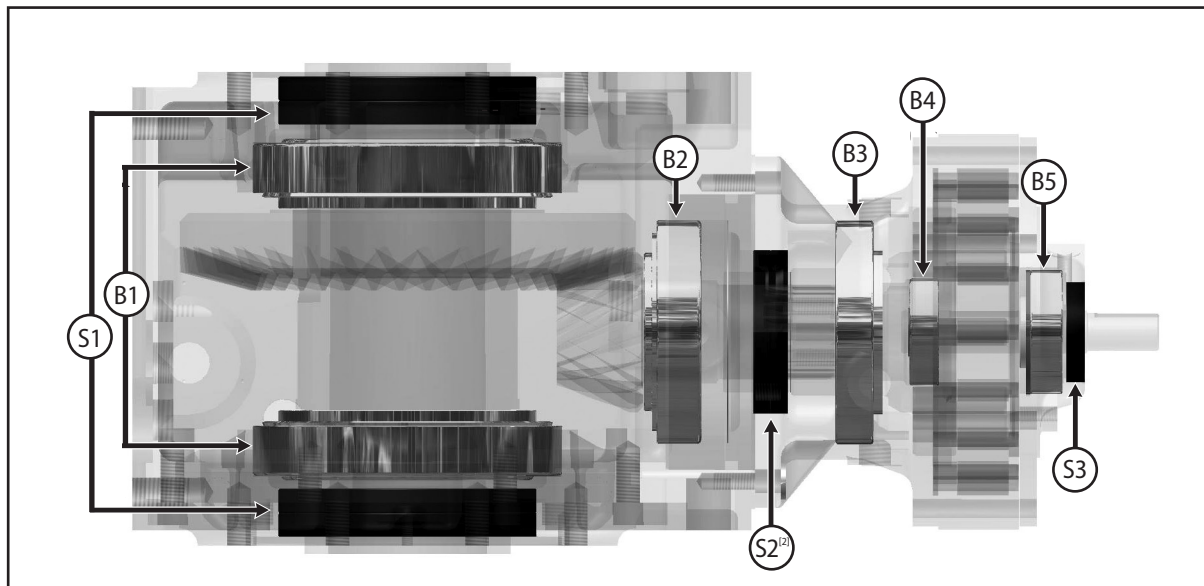

Table 47. Cyclo® BBB4 Reducer Bearings and Oil Seals

Unit Size	Bearings					Oil Seals ^[1]		
	B1	B2	B3	B4	B5	S1 ^[2]	S2 ^[3]	S3
4A100 4A105 4A110 4A115	32017	32308	32011	6302RSH2	6302Z	D 85 x 110 x 13	S 50 x 68 x 9	S 20 x 35 x 7
4A120 4A125			32013	6304	6305Z			D 32 x 52 x 8
4A140 4A145			32015	6305R	6306			D 38 x 58 x 11
4B120 4B125			32020	32310	32013			6304
4B140 4B145	32015	6305R			6306	D 38 x 58 x 11		
4B160 4B165	32017	6307R			6308	D 55 x 78 x 12		
4C140 4C145	32024	32312			32015	6305R	6306	D 120 x 150 x 14
4C160 4C165			32017	6307R	6308	D 55 x 78 x 12		
4C170 4C175			32022	6406	6407	D 60 x 82 x 12		
4D160 4D165			32028	32314	32017	6307R	6308	
4D170 4D175	32020	6406			6407	D 62 x 82 x 12		
4D180 4D185	32022	6407			6409	D 65 x 88 x 12		
4E170 4E175	32032	32315			32020	6406	6407	D 160 x 190 x 16
4E180 4E185			32022	6407	6409	D 65 x 88 x 12		
4E190 4E195			32026	6408	6411	S 70 x 88 x 10		
4F180 4F185			32036	32319	32026	6407	6409	
4F190 4F195	32023	6408			6411	S 70 x 88 x 10		

Notes: [1] D = Double Lip Seal. S = Single Lip Seal. Seal Dimensions are in mm.
 [2] A total of 4 seals are needed - two on top and two on bottom
 [3] for "Y4" assembly and grease lubricated units only

Parts, continued

Bevel Gearing Parts and Tooth Count

Bevel Gearing Parts and Tooth Count

Bevel gear and pinions are sold in sets only. Individual components are not available for purchase. The information below regarding tooth count of the bevel gearset is provided for vibration analysis purposes.

Figure 35. Cyclo® BBB4 Bevel Gearing Tooth Count

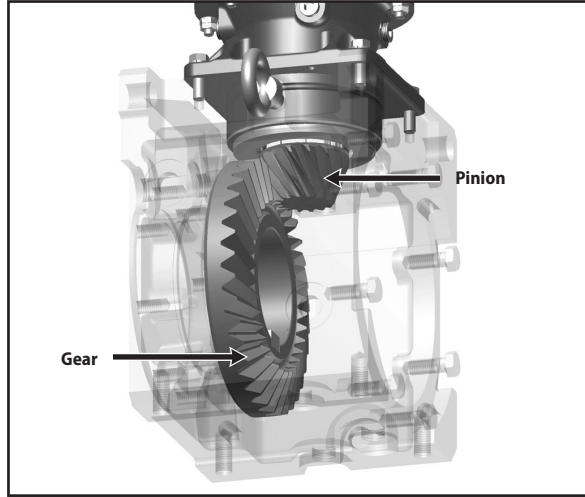

Table 48. Cyclo® BBB4 Ratios

Cyclo® BBB4 Nominal Ratio	Bevel Ratio	Cyclo® Input Ratio
11	3.5	3 ^[1]
13	3.2	4 ^[1]
14	3.5	4 ^[1]
16	3.2	5 ^[1]
18	3.5	5 ^[1]
19	3.2	6
21	3.5	6
22	3.2	7
25	3.5	7
26	3.2	8
28	3.5	8
35	3.2	11
39	3.5	11
42	3.2	13
46	3.5	13
48	3.2	15
53	3.5	15
54	3.2	17
60	3.5	17
67	3.2	21
74	3.5	21

Note: [1] Planetary Input

Cyclo® BBB4 Nominal Ratio	Bevel Ratio	Cyclo® Input Ratio
80	3.2	25
88	3.5	25
93	3.2	29
102	3.5	29
112	3.2	35
123	3.5	35
138	3.2	43
151	3.5	43
163	3.2	51
179	3.5	51
189	3.2	59
207	3.5	59
227	3.2	71
249	3.5	71
278	3.2	87
305	3.5	87
364	3.5	104
417	3.5	119
424	3.5	121
501	3.5	143
578	3.5	165
683	3.5	195

Cyclo® BBB4 Nominal Ratio	Bevel Ratio	Cyclo® Input Ratio
809	3.5	231
956	3.5	273
1117	3.5	319
1320	3.5	377
1656	3.5	473
1957	3.5	559
2272	3.5	649
2559	3.5	731
2944	3.5	841
3511	3.5	1003
4365	3.5	1247
5177	3.5	1479
6472	3.5	1849
7228	3.5	2065
8880	3.5	2537
10658	3.5	3045
12184	3.5	3481
15530	3.5	4437
17966	3.5	5133
21620	3.5	6177
26492	3.5	7569

To determine the bevel tooth count, identify the Cyclo® BBB4 nominal ratio and corresponding bevel ratio from Table 49. Then reference Table 45 to identify the actual number of bevel gear and pinion teeth.

Table 49. Bevel Tooth Count and Part Numbers

Bevel Ratio	Number of Teeth		Bevel Gear Set Part Number						
	Pinion	Gear	4A10, 4A11 4A12, 4A14	4B12, 4B14, 4B16	4C14, 4C16, 4C17	4D16	4D17, 4D18	4E17, 4E18, 4E19	4F18, 4F19
3.2	10	32	998BBB-4A--BG	998BBB-4B--BG	998BBB-4C--BG	998BBB-4D16BG	998BBB-4D17BG	998BBB-4E--BG	998BBB-4F--BG
3.5	10	35	998BBB-2A---G	998BBB-2B---G	998BBB-2C---G	998BBB-2D---G	998BBB-2D17-G	998BBB-2E---G	998BBB-4F--AG

Screw Conveyor Options

Components, Assembly Instructions

Screw Conveyor Components

Figure 36. Cyclo® BBB4 Screw Conveyor Components

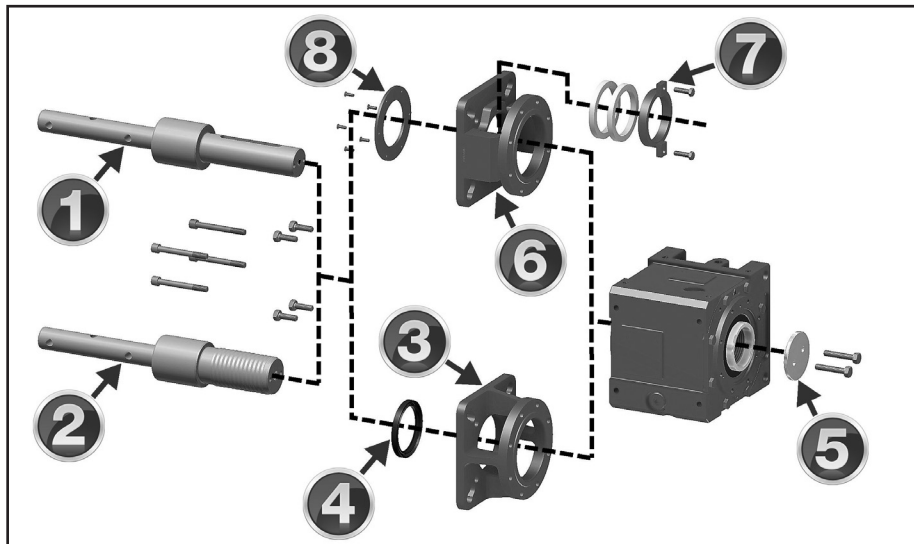
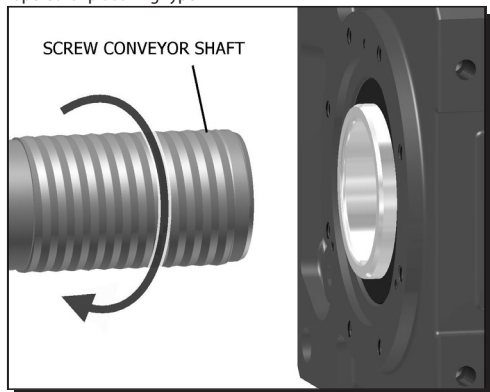

Table 50. Typical Cyclo® BBB4 Screw Conveyor Components

Item Number	Description
1	Screw Conveyor Shaft for KHB
2	Screw Conveyor Shaft for TGB
3	Cast Screw Conveyor Adapter
4	Shaft Seal
5	Shaft Retaining Plate
6	Fabricated Screw Conveyor Adaptor
7	Optional Braided Cord Packing Seal
8	Optional Gland Cover Plate

Screw Conveyor Assembly Instructions

Tapered Grip Bushing Type



1

Insert the **screw conveyor shaft** completely into the Cyclo® BBB4 **output hub**.

Tapered Grip Bushing Type – Screw the threaded end into the BBB unit.

Keyed Type

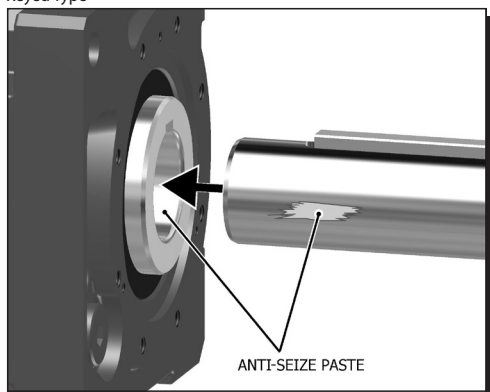

Keyed Type – Apply anti-seize paste to the driven shaft, install key into shaft keyway, align the key and hollow shaft keyway and carefully slide the shaft into the BBB unit

Screw Conveyor Options, continued

Assembly Instructions

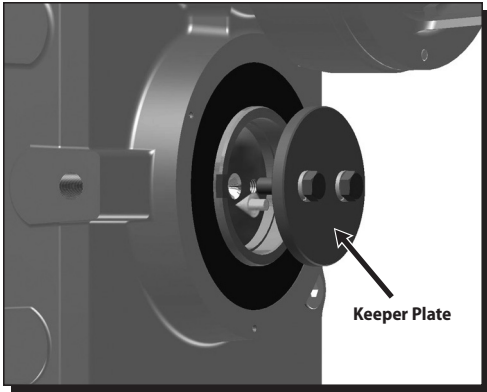

2

Secure the screw conveyor shaft in place using the **keeper plate** with the supplied hardware.

Table 51. Bolt Tightening Torques

Unit Size	Shaft Retaining Bolts	
	Qty. x Bolt Size	Bolt Torque (ft-lbs)
4A	2 x M10	33
4B	2 x M10	33
4C	2 x M12	59
4D	2 x M16	146
4E	2 x M16	146

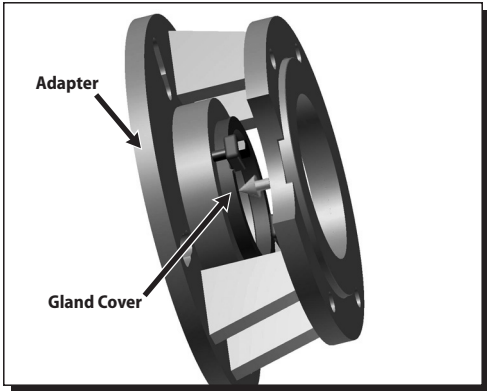

3

If braided cord is supplied, place the **gland cover** into the screw conveyor adapter and secure it in place with the supplied hardware.

Cover not required with the use of a lipped seal.

Table 52. Bolt Tightening Torques

Unit Size	Gland Cover Bolts	
	Qty. x Bolt Size	Bolt Torque (ft-lbs)
4A	2 x M8	15
4B		
4C		
4D		
4E		

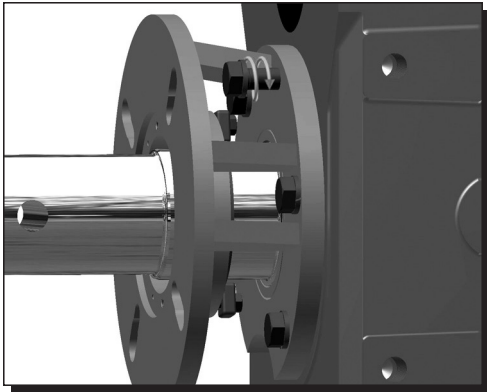

4

Carefully slide the screw conveyor adapter over the shaft and position it against the corresponding threaded holes in the Cyclo® BBB4 housing. Use the included hardware to secure the adapter to the housing.

Table 53. Bolt Tightening Torques

Unit Size	Cast Adapter/Housing Bolts		Fabricated Adapter/Housing Bolts	
	Qty. x Bolt Size	Bolt Torque (ft-lbs)	Qty. x Bolt Size	Bolt Torque (ft-lbs)
4A	8 x M10 (HH)	47	4 x M10 (HH)	47
			4 x M10 (SHCS)	57
4B	8 x M12 (HH)	83	4 x M12 (HH)	83
			4 x M12 (SHCS)	100
4C	8 x M16 (HH)	202	4 x M16 (HH)	202
			4 x M16 (SHCS)	247
4D	8 x M20 (HH)	401	4 x M20 (HH)	401
			4 x M20 (SHCS)	285
4E	8 x M20 (HH)	401	8 x M20 (HH)	401

Screw Conveyor Options, continued

Assembly Instructions

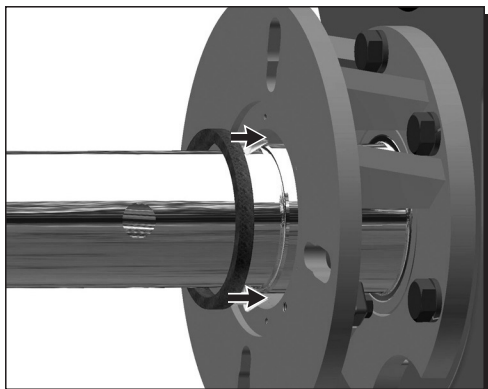

5

If supplied, carefully insert the application appropriate **sealing material** into the bore of the screw conveyor adapter.

- To seal the output portion of the screw conveyor adapter, Sumitomo provides two different options for each screw conveyor kit:
 - High-Performance Braided Cord: recommended for use if the conveyed material is abrasive.
 - Double-Lip, Nitrile Oil Seal: recommended for use if conveyed material is a nonabrasive liquid.
- Sumitomo **does not** recommend the use of both sealing options at the same time.

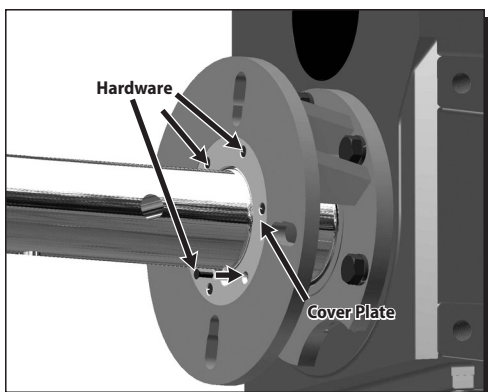

6

If using the **braided cord seal**, carefully slide the **cover plate** over the screw conveyor shaft and place it against the screw conveyor adapter. Secure the cover plate using the supplied hardware.

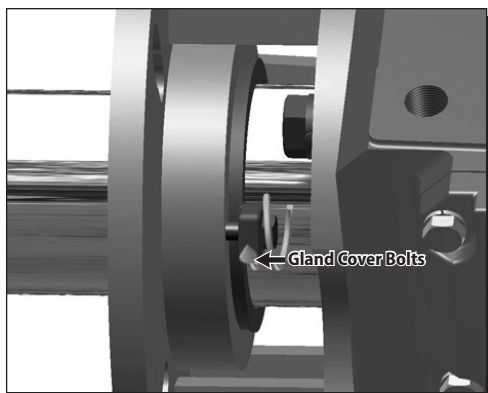

7

If using the **braided cord seal**, tighten the **gland cover bolts** to achieve sufficient sealing on the screw conveyor shaft.

Cyclo® Portion Disassembly/Assembly

Disassembly Procedure

Disassembly/Assembly

The Bevel Gear portion is designed for lower speeds and therefore has lower operating cycles when compared to the Cyclo® input assembly, therefore in most cases does not require rebuilding. Always consult our specialized factory and warehouses for overhaul of gearmotors and reducers. Experience is necessary for proper overhaul.

The Cyclo® portion has significantly higher operating cycles than the Bevel Gear portion, rebuild and repair is a convenient way to extend the useful life of your gearbox.



Cyclo® repairs should be conducted by experienced personnel to prevent damage to components or persons.

Cyclo® Portion – General Disassembly

1

Before starting the disassembly process, Sumitomo recommends draining and properly disposing of all lubrication.

2

Carefully remove the entire Cyclo® BBB4 from the driven shaft by following the instructions outlined in the Removal From Driven Shaft section of this manual.



3

While carefully supporting the entire unit, place the unit on a level work surface so that the high speed portion (Cyclo® portion) is facing down.

Cyclo® Portion Disassembly/Assembly, *continued*

Disassembly Procedure

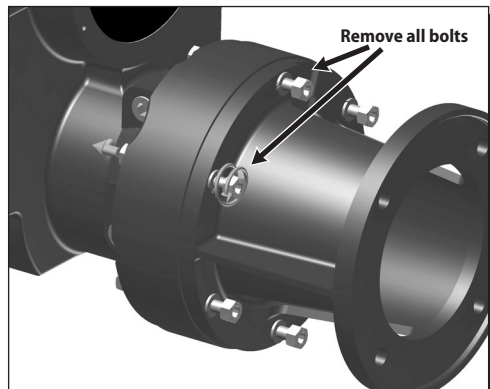

4

While continuing to externally support the entire Cyclo® BBB4 unit, remove each of the bolts from the Cyclo® ring gear housing (shown in horizontal position for clarity).

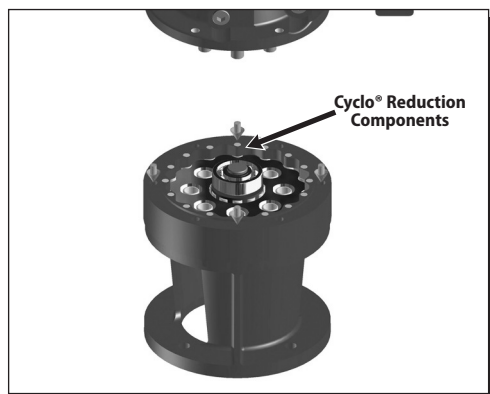

5

Carefully separate the **bevel gear housing assembly** from the Cyclo® portion to gain access to the Cyclo® reduction components.

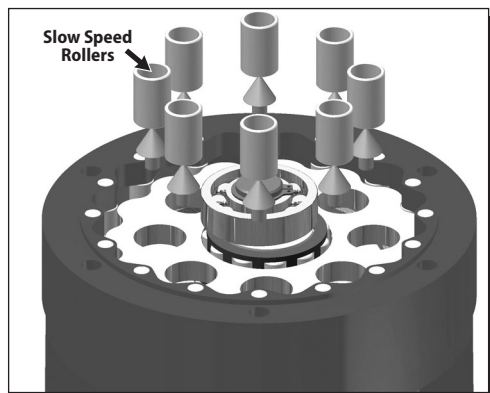

6

Remove the **slow speed rollers**. Additionally, check the pins on the pin carrier to see if any of the rollers have adhered to them.

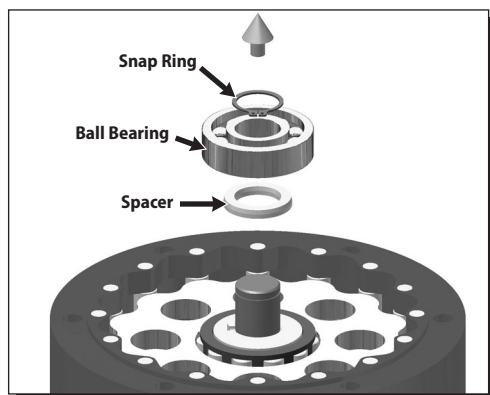

7

Remove the **snap ring**, the **ball bearing** and the **spacer** from the high speed shaft.

Cyclo® Portion Disassembly/Assembly, continued

Disassembly Procedure

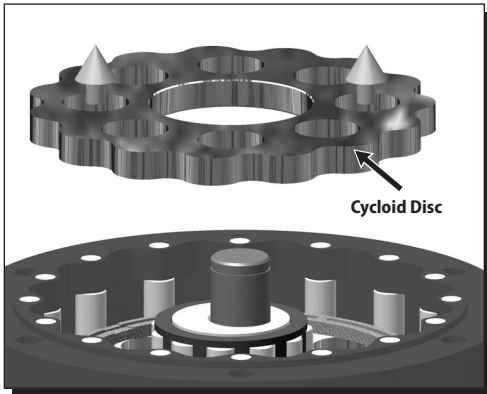

8

Using both hands, carefully remove the top **Cycloid disc**.

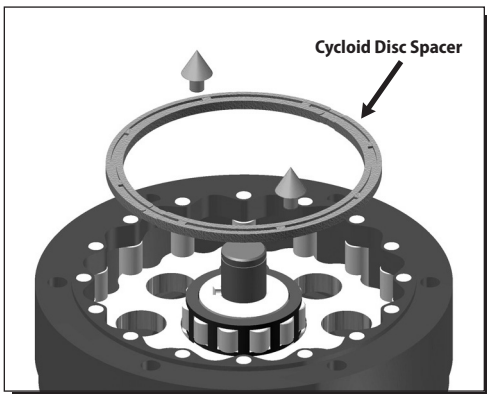

9

For Cyclo® units supplied with a **spacer**, remove the **Cycloidal disc spacer**.

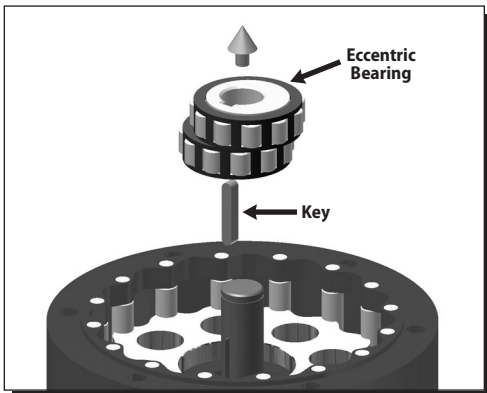

10

Remove the **eccentric bearing** from the high speed shaft.

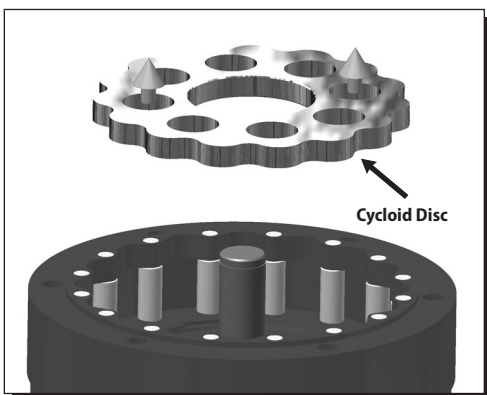

11

Using both hands, carefully remove the remaining **Cycloid disc**.

Cyclo® Portion Disassembly/Assembly, *continued*

Disassembly Procedure

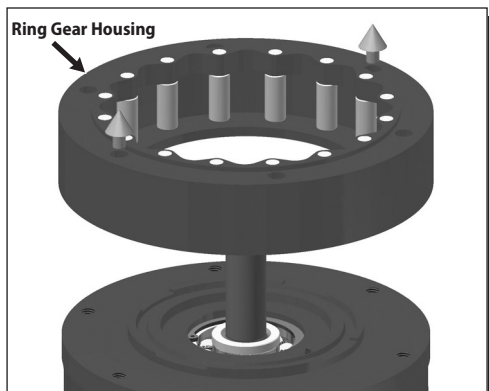

12

Remove the **ring gear housing**

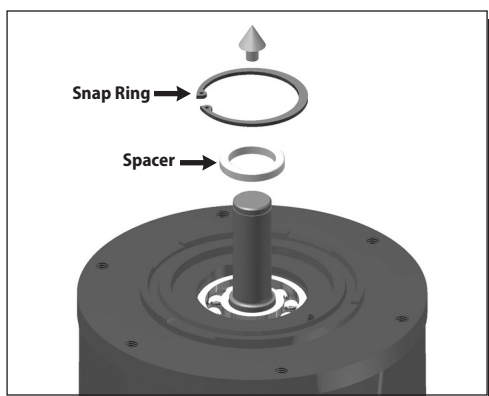

13

Remove the **spacer** and the **snap ring** from the **high speed end shield**.

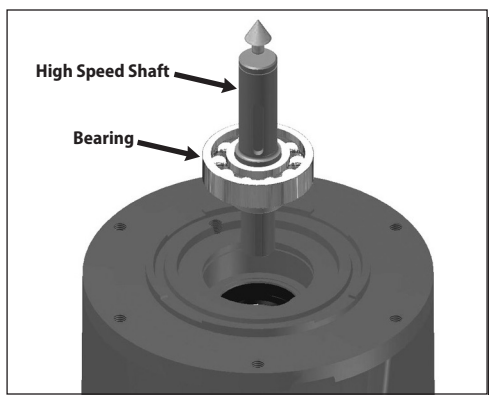

14

Remove the **high speed shaft**, along with its associated bearing, from the **high speed end shield**.

Cyclo® Portion Disassembly/Assembly, continued

Reassembly Procedure

Cyclo® Portion – General Reassembly

The Cyclo® portion of the speed reducer may be reassembled by reversing the disassembly procedure. All parts must be returned to the original order from which they were removed during disassembly. Take care to keep the moving reduction components free of dust or foreign material, and properly align all gaskets in order to keep the assembly oil tight/leak free.

Remember these important notes when assembling the Cyclo® reducer:

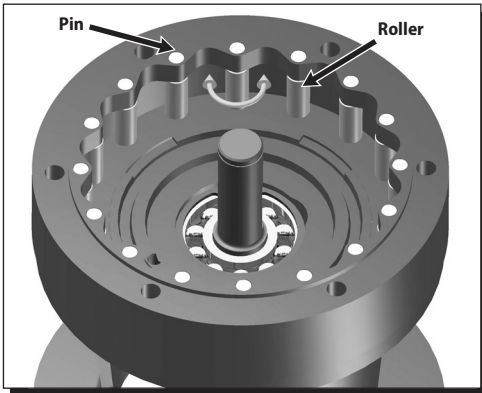

1

Place the **ring gear housing** on the Cyclo® **high speed end shield** (or the motor flange) and insert the ring gear housing **pins** and **rollers** (if they had been removed during the disassembly process). Rotate each of the pins and rollers by hand to assure that they freely move/rotate.

If the Cyclo® portion of the Cyclo® BBB4 is grease lubricated, liberally apply grease to the ring gear pins and rollers before they are inserted into the ring gear housing.



If the Cyclo® portion of the Cyclo® BBB4 unit is oil lubricated – do not add any grease during the reassembly process.

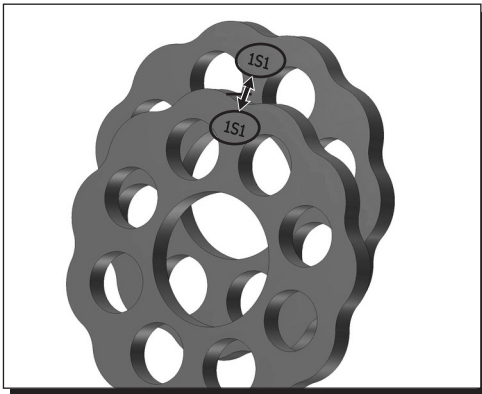

2

Cycloid discs are a matched pair, both discs have the same code etched on one side.

When inserting these discs into the ring gear housing, be sure that the etched number is facing up.

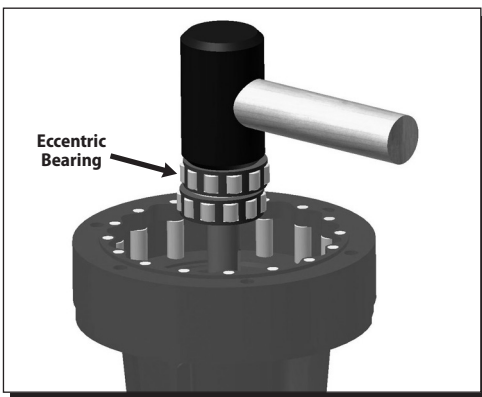

3

When reinserting the **eccentric bearing assembly**, use only a wooden or hard rubber mallet to tap it into place.

Cyclo® Portion Disassembly/Assembly, continued

Reassembly Procedure

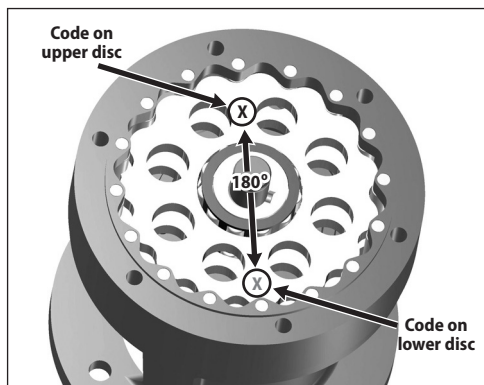

4

Insert the **top Cycloid disc** so that the code engraved on its surface is 180° opposed to the corresponding etched code on the **lower Cycloid disc**.

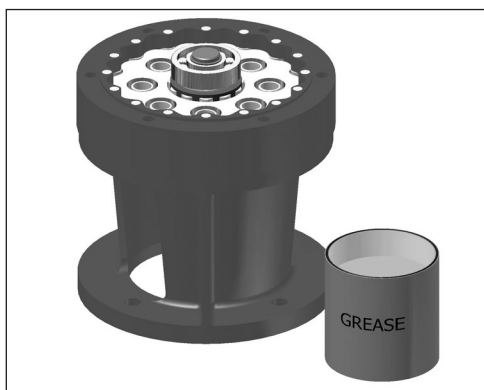

5

If the Cyclo® portion of the Cyclo® BBB4 unit is grease lubricated, refill the reduction components with the amount specified in Grease Quantities section of this manual; **or**, fill to 80% of the space around the reduction mechanism and bearings of single reduction units, and 50% of the space around the reduction mechanism of both the first and second stage of double reduction units.



If the Cyclo® portion of the Cyclo® BBB4 unit is oil lubricated – do not add any grease during the reassembly process.

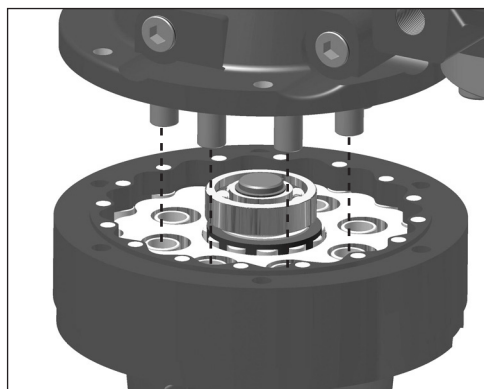

6

When reassembling the Cyclo® BBB4 gear housing onto the Cyclo® reduction stage, ensure that the **carrier pins** are inserted and aligned with the corresponding bores of the **rollers**.

Troubleshooting

Reducer Troubleshooting

Reducer Troubleshooting

This troubleshooting guide provides assistance in identifying and overcoming common problems with reducers and motors. If a problem with the reducer and/or the motor is not listed below, please consult the factory for assistance.

Reducer Troubleshooting

Problem with the Reducer		Possible Causes	Suggested Remedy
Runs Hot	Overloading	Load exceeds capacity of the reducer	Check the rated capacity of the reducer, replace with unit of sufficient capacity or reduce the load
	Improper lubrication	Insufficient lubricant	Check lubricant level and increase to recommended level
		Excessive lubricant	Check lubricant level and reduce to recommended level
		Incorrect lubricant	Flush old lubricant from the unit and refill with correct recommended lubricant
Vibration or Noise	Loose foundation bolts	Weak mounting structure	Inspect mounting of reducer. Tighten loose bolts and/or reinforce mounting & structure
		Loose hold-down bolts	Tighten bolts
	Worn disc and/or bevel gearing	Load exceeds capacity of reducer	If bevel gearset is damaged, contact the factory. If Cycloid discs are damaged, disassemble the Cyclo® portion and replace discs. Re-check the rated capacity of the unit
	Bearing failure	Insufficient lubricant	If output bearings are damaged, contact the factory If bearings in Cyclo® portion are damaged, replace the affected bearings. Clean & flush the reducer and fill with the correct type and quantity of lubricant
		Load exceeds capacity of reducer	Check the rated capacity of the reducer. Replace with unit of sufficient capacity or reduce the driven load
	Insufficient lubricant	Insufficient lubricant	Check lubricant level and adjust to recommended level
Damaged Cyclo® pins and rollers	Load exceeds capacity of reducer	Disassemble Cyclo® portion of reducer and replace ring gear housing pins and rollers. Check load on reducer	
Output Shaft/Hub does not turn	Motor shaft broken	Load exceeds capacity of reducer or repetitive shock loading	Replace broken shaft. Check rated capacity of reducer
	Key missing or sheared off on input shaft		Replace key
	Eccentric bearing broken	Insufficient lubricant	Replace the Eccentric Bearing in the Cyclo® portion. Flush and refill the unit with the recommended lubricant
	Motor does not turn	Motor	Refer to the "Motor" portion of this Troubleshooting guide
Oil Leakage	Worn seals	Caused by dirt or grit entering the seal area	Replace the oil seals
	Leakage into motor	Excessive lubricant	Check the lubricant level and adjust to the recommended level
		Air breather clogged	Clean or replace element, being sure to prevent any dirt from falling into the reducer
		Improper mounting position, such as other than designed mounting angle	Mount the unit in its designed mounting angle

Troubleshooting, continued**Motor Troubleshooting****Motor Troubleshooting**

Problem with the Motor		Possible Causes	Suggested Remedy
Load is disconnected but motor does not rotate	Makes a "groaning" sound	Faulty switch contact	Adjust the contact
		Blown fuse	Replace fuse
		One phase wire of the power supply open	Rewire connection
		Stator coil open	Repair by rewinding or replacing the stator assembly
		Stator and rotor touching due to bearing housing wear	Replace the bearing and bracket
	Starts in either direction when turned by hand	Three-phase is operating as singlephase	Consult the power source with a voltmeter
	Doesn't make any noise	Stator coil open	Repair by rewinding or replacing stator assembly
		External power failure	Contact the local power company.
Open connection wire Faulty Switch contact Faulty Starter contact		Check the source wiring Adjust the contacts	
Rotates with the load disconnected but:	Rotates in the wrong direction	Connection error	Change any two of the three-phase source connections
	Fuse blows	Shorted lead wire	Replace fuse and rewire short
	Speed does not increase	Faulty starter contact	Replace or adjust starter contact
	Makes a "groaning" sound	Overcurrent/Overheating due to Rotor and Stator touching	Repair by rewinding or replacing stator assembly
		Overcurrent due to one phase of Stator Coil shorted	Replace the stator winding
	Makes a highpitched "metallic" noise	Faulty bearing	Replace the bearing
Rotates when the load is disconnected but when the load is connected:	Switch overheats	Insufficient switch capacity	Replace with switch having the rated capacity
		Overload	Decrease load to the rated value
	Fuse blows	Insufficient fuse capacity	Replace with fuse having the rated capacity
	Overheats	Overload	Decrease load to rated value
		Voltage drop	Consult with local power company
	Speed suddenly drops	Voltage drop	Consult with local power company
		Overload	Decrease load to rated value
	Stops	Bearing damaged by overheating	Replace the bearings

Headquarters & Manufacturing

◆ Sumitomo Machinery Corporation of America

4200 Holland Boulevard
Chesapeake, VA 23323

Tel: 757-485-3355 • 1-800-SMCYCLO

Fax: 757-485-7490

www.sumitomodrive.com

E-mail: sma.service@shi-g.com

After Hours Technical Support

Tel: 1-800-983-1000



www.sumitomodrive.com/BBB4

World Headquarters

Japan
Sumitomo Heavy Industries, Ltd.
Power Transmission & Controls Group
ThinkPark Tower, 1-1, Osaki 2-chome,
Shinagawa-ku, Tokyo 141-6025 Japan
Tel: +81-36-737-2511 • Fax: +81-36-866-5160

*For facilities located in the Americas, please visit
www.sumitomodrive.com/locations*

*For worldwide locations, please visit
www.sumitomodrive.com/worldwide*