



Sumitomo Drive Technologies

Sumitomo Drive Technologies

Sumitomo, Hansen and Seisa. Three brands, one global power transmission solutions provider. Sumitomo Drive Technologies has facilities strategically located throughout the world, providing comprehensive products and services in your region.



- ★ MANUFACTURING HUB
- ASSEMBLY & SERVICE
- ▲ REGIONAL SALES OFFICE

Sumitomo Machinery Corporation of America
www.SumitomoDrive.com

For worldwide locations, please visit www.sumitomodrive.com/worldwide
Contact your local representative at www.sumitomodrive.com/representative
Tel: 1-800-SM-CYCLO (762-9256) 01.H02.51.002 P4 Brochure 2020

P4 HANSEN P4

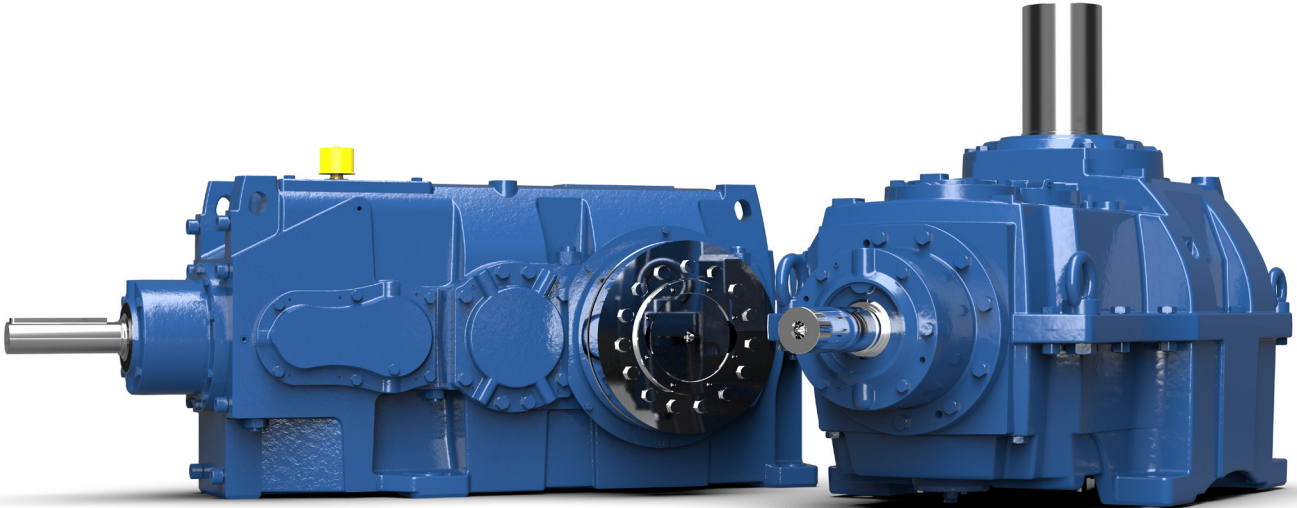

- Vertical
- Horizontal
- Single-Stage

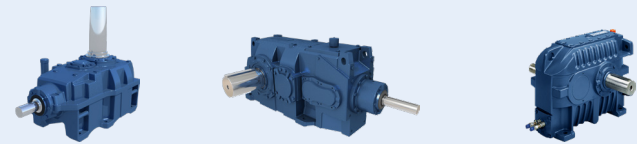

VARIATIONS

- Hollow Shaft - Shrink Disc
- Normal Solid Shaft
- Hollow Shaft - Keyed
- Oversized Solid Shaft
- Extended Bearing Housing

VERTICAL SHAFT OPTIONS

- Extended Bearing
- Pilot or Flange Mount
- Hollow Shaft



OUTPUTS

SPLIT HOUSING

Rugged, split housing for horizontal and vertical applications. Round housing tops help keep the unit free from debris.

GEARS

High torque geometry in low-speed gears. Low-noise geometry in high-speed gears.

PINION SHAFTS

Rigid standardized pinion shafts and housings for better lateral load distribution.

SLOW-SPEED SHAFT

Shaft projections include captured keyways with rounded end key inserts to eliminate stress concentrations.

INTERNAL HOUSING

Exceptional construction ensures bearings are lubricated at start-up to maximize reliability and life.

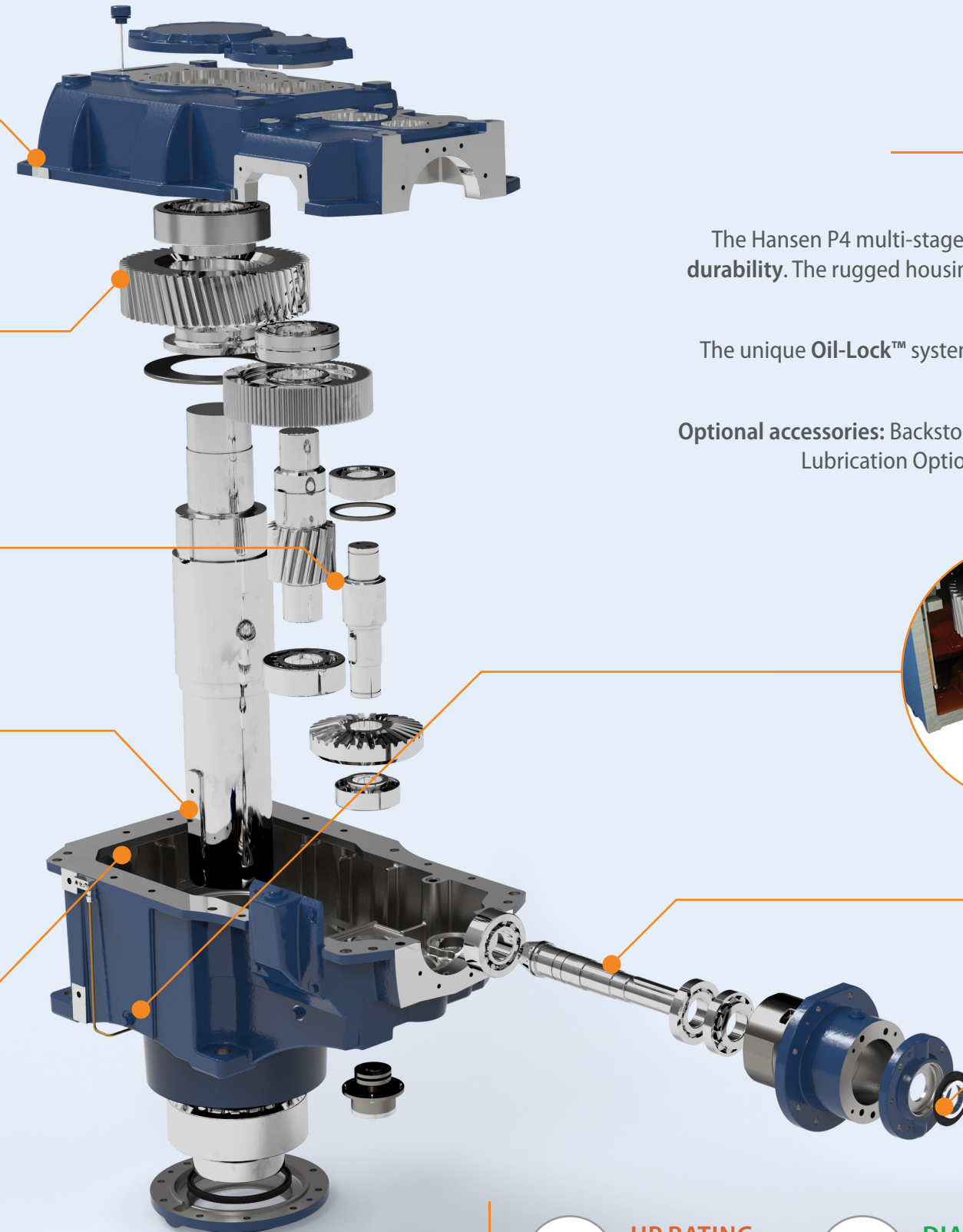

P4 HANSEN P4

REMARKABLE POWER AND PERFORMANCE WITH LOW NOISE

The Hansen P4 multi-stage gear unit is market leading in quality and technology, excelling in reliability and durability. The rugged housing, along with our commitment to innovating state-of-the-art technology, provides remarkable power and performance.

The unique Oil-Lock™ system offers a maintenance-free seal on high speed shaft extensions, designed to keep the oil in and dirt out.

Optional accessories: Backstops, Motor Mount Options, Multiple Sealing Upgrades, Various Heating, Cooling, and Lubrication Options, Heavy Duty Paint or Packaging Options, and Complete Drive Package Solutions.

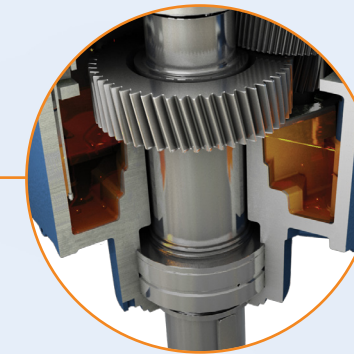

INTEGRATED DRYWELL

Cast into 3 and 4 stage vertical housings mean this option provides a truly leak-proof low-speed shaft.

HIGH-SPEED SHAFT

Extra long high-speed shaft projections suitable for interference-free coupling connections.

MAINTENANCE-FREE OIL-LOCK®

Standard high-speed seal arrangement.

OPTIONS

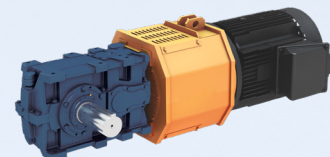

UniMiner

Flippable housing and horizontal split line make the ideal alignment-free drive package for mining

SPECS



HP RATING
Up to 14,080 HP
(10,500 kW)



DIAMETER
80mm to 400mm
(Solid, Heavy-Duty,
and Hollow)



TORQUE
Up to 9.7 million lb•in
(1.1 million N•m)



RATIO RANGE
Up to 630:1 (Custom
ratios available)